

T. A. Bryan,

2. Sheets, Sheet 1.

Flood Bridge.

No. 100,995.

Patented Sept. 6, 1870.

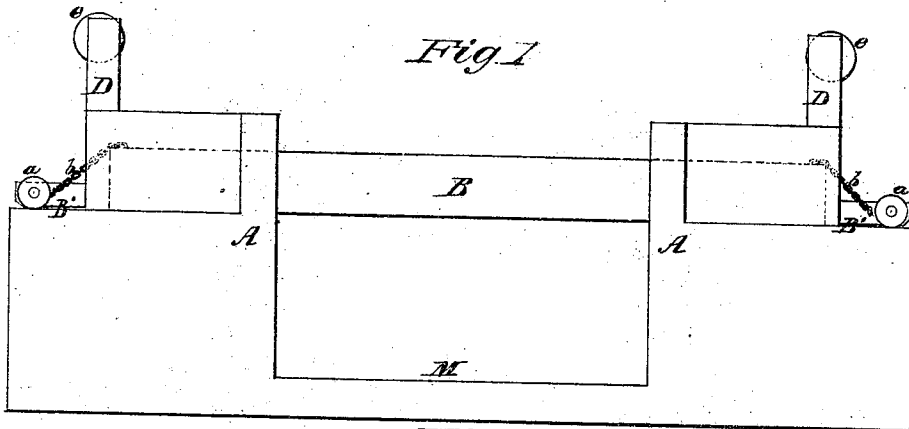
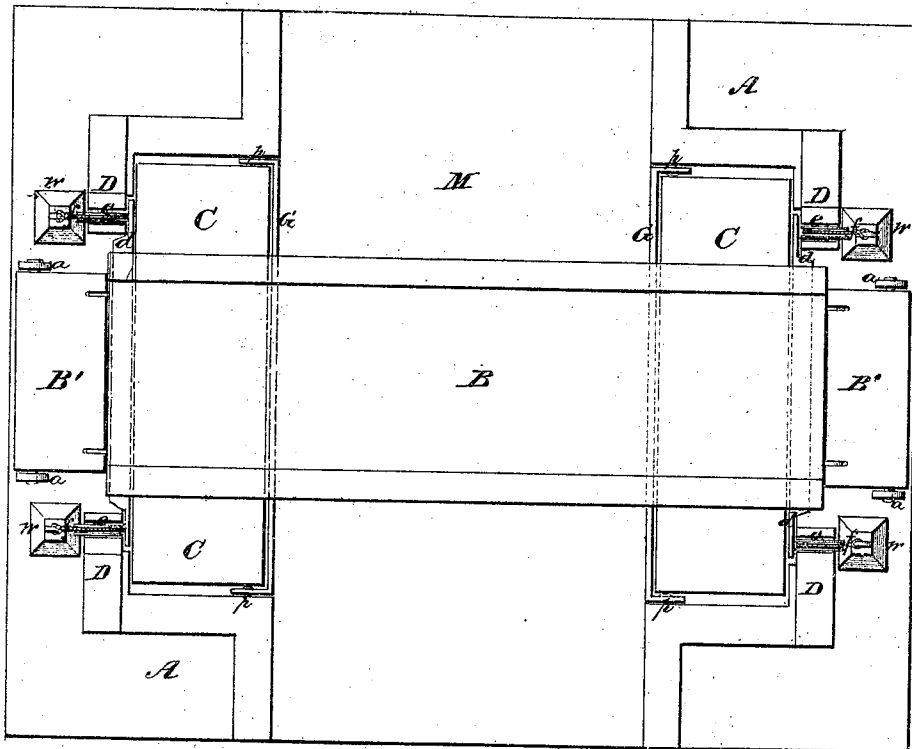

Fig. 2



Witnesses
R. J. Campbell.
J. M. Campbell.

Inventor
Thos. A. Bryan
by
Mason, Hewick & Lawrence

T. A. Bryan,
Flood Bridge.

2 Sheets, Sheet 2,

No. 106,995.

Patented, Sept. 6. 1870.

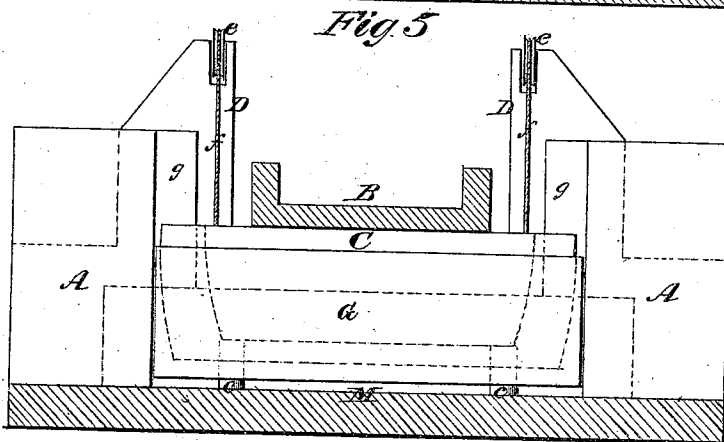
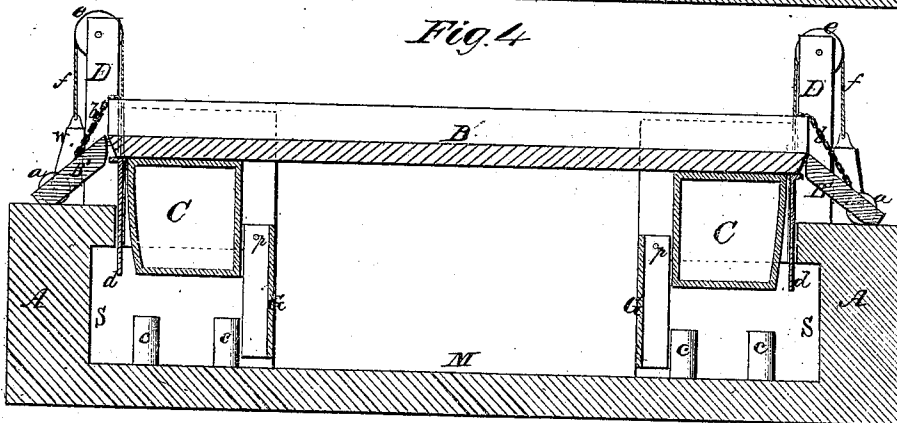
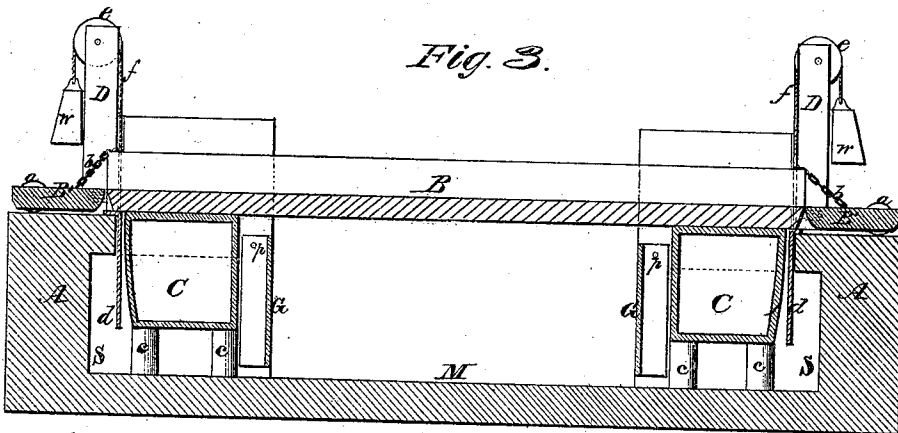

Witnesses
R. J. Campbell.
J. O. Campbell.

Inventor
Thos. A. Bryan
by
Mason, Smith & Lawrence.

United States Patent Office.

THOMAS ALFRED BRYAN, OF BALTIMORE, MARYLAND.

Letters Patent No. 106,995, dated September 6, 1870.

IMPROVEMENT IN FLOOD-BRIDGES.

The Schedule referred to in these Letters Patent and making part of the same

To all whom it may concern:

Be it known that I, THOMAS ALFRED BRYAN, of the city and county of Baltimore, in the State of Maryland, have invented certain new and useful Improvements in the Construction of Flood-Bridges; and I do hereby declare that the following is a full, clear, and exact description thereof, reference being had to the accompanying drawing making part of this specification, in which—

Figure 1, plate 1, is a side elevation of the improved bridge and its supports.

Figure 2, plate 1, is a top view of the same.

Figure 3, plate 2, is a section taken longitudinally and vertically through the bridge and its supports.

Figure 4, plate 2, is a similar view of the same parts shown in fig. 3, indicating the bridge in an elevated position.

Figure 5, plate 2, is a vertical cross-section through the bridge.

Similar letters of reference indicate corresponding parts in the several figures.

The objects of this invention are—

First, to so construct and support a bridge that it will be sustained, under ordinary occasions, upon a solid foundation, and, when the water in the stream over which the bridge crosses rises above a given level, the bridge will be buoyed up, and will then rise and descend with the rise and fall of the water, without seriously interfering with travel across it.

Second, to extend the side walls, between which the ends of the bridge are received, above the level of the roadway, high enough to prevent overflow of the banks at such points, and to employ movable curtains in combination therewith, which curtains will rise and fall with the ends of the bridge, and prevent the overflow of water into the roadway between said side walls.

Third, to provide against the collection of any serious amount of floating material beneath the ends of the bridge, and to so construct the passages thereunder that free access can be obtained to them for repairs and other purposes.

Fourth, to adapt the several parts which enter into the construction of the bridge to move freely, without liability to bind.

To enable others skilled in the art to understand my invention, I will explain its construction and operation.

I construct, upon opposite sides of the canal, creek, or stream, on or nearly on a level with the bed of the same, a solid foundation, from which strong walls, A A, of masonry, are erected, which are adapted to receive between them the ends of the bridge B. These walls at the side of the bridge are extended above the level of the roadway, above the highest watermark, but the walls at the extremities of bridge, in

line with the roadway, terminate on a level with the latter, as shown in figs. 3 and 4, and afford supports for the ends of the bridge when the same is not buoyed up by the rise of the water.

These side and end walls are also so constructed that the upper portions of them overhang the lower portions, and thereby afford chambers S, which will allow persons to pass around the buoys C, and repair or clear out the chambers, when this is necessary.

To the bottom of the bridge B, near each end thereof, hollow floats C are secured. These floats or buoys are made of strong boiler-iron, air-tight, and of a capacity adapted to float the bridge and all ordinary weights which may be upon it. These floats extend transversely across the space between the side walls A A, so that these walls, as well as the end walls, will serve as guides for the bridge and floats, and resist lateral as well as longitudinal movements thereof.

To prevent the ends and outer sides of the float C from binding between the side and end walls, in consequence of the bridge not maintaining an exact level while it is floating in the water and rising and descending, I curve the extremities of each float, as indicated by the dotted lines, fig. 5. These curves are struck from the upper corners of the ends of each float, so that, whatever inclination the floats may assume, they will not bind between the side walls. The outer sides of the floats C are curved, so that the tilting of the ends of the bridge will not cause it to bind between the opposite end walls. These curves are struck from the upper and outer corners of the opposite floats.

Beneath the floats are piles or other suitable supports c rising from the bed of the stream, and intended to afford support to the floats when the ends of the bridge rest upon the end walls, as shown in figs. 3 and 5.

On those sides of the floats C C next the stream, guards G G are applied, between the side walls A A, and pivoted at p p, so as to swing freely. Each guard extends from a point near the level of the roadway to a point near the bed of the stream, and thus closes in the space which receives the float, and, while a free circulation of water into and out of the said space is not prevented by the guard, it will operate as a protection to the float against the great force of a rapidly-flowing current. Each guard will also prevent the accumulation of large floating substances within the space inclosed by it. By having the guards hinged they can be drawn out from below to allow persons to enter the passages S.

Between the end walls and the floats, curtains d d are applied, which are held up in contact with the bottom of the bridge at all times by means of weights w w, which are hung from cords that are connected

to the upper edges of each curtain *d*, and passed over grooved pulleys *e e*, at the upper ends of column D.

The curtains *d d* extend down about as far as the bottoms of the floats, and, when the bridge is buoyed up by the rise of water, these curtains will be forced tightly against the upper overhanging portions of the end walls, by the pressure of water, thus preventing any considerable amount of water from escaping into the roadway at these places.

The extremities of each curtain *d* are curved, as shown by dotted lines, fig. 5, which will prevent the curtain from binding between the side walls A A.

The ends of the floor of the bridge B terminate in hinged portions B' B', the outer ends of which are sustained by rollers or wheels *a a*, as shown in the drawing.

It will be seen from the above description that I am enabled to maintain a bridge at all times above the level of the water in the stream, and at the same time render the bridge passable and safe. I also provide for keeping back the water from the roadway, notwithstanding the level of the water of the stream may be above the level of the roadway. By thus constructing a bridge it will be sustained in just as substantial a manner as bridges constructed upon the old plans, and, while this is the case, the bridge will rise and descend with the rise and fall of the water after the water rises above a given level, and will not be in any serious manner affected by the force of the current, inasmuch as the floats or buoys C C will be in comparatively still water.

I am aware that bridges have hitherto been constructed upon floating objects, so as to rise and fall with the tides, and, therefore, I do not claim, broadly, a floating bridge.

Having described my invention,

What I claim as new, and desire to secure by Letters Patent, is—

1. The floats C C, arranged beneath the bridge B, within spaces inclosed by side and end walls A A, and a guard, G, substantially as described.

2. The aprons *d* applied at the ends of the bridge, between the float C and the end walls, and arranged to rise and descend with the ends of the bridge, substantially as described.

3. The passages S, in combination with the hinged guards G and a bridge which will float, substantially as described.

4. The construction of the floats C, with rounded or inclined ends and sides, substantially as and for the purposes explained.

5. A bridge which, during ordinary tides, will be substantially supported upon solid masonry, and which is so constructed with floats that, during an extraordinary rise of water, will be buoyed up, and thus sustained above the level of the water, substantially as described.

THOMAS ALFRED BRYAN.

Witnesses:

FRANCIS LAMOTTE,
JOSEPH H. LINTON.