

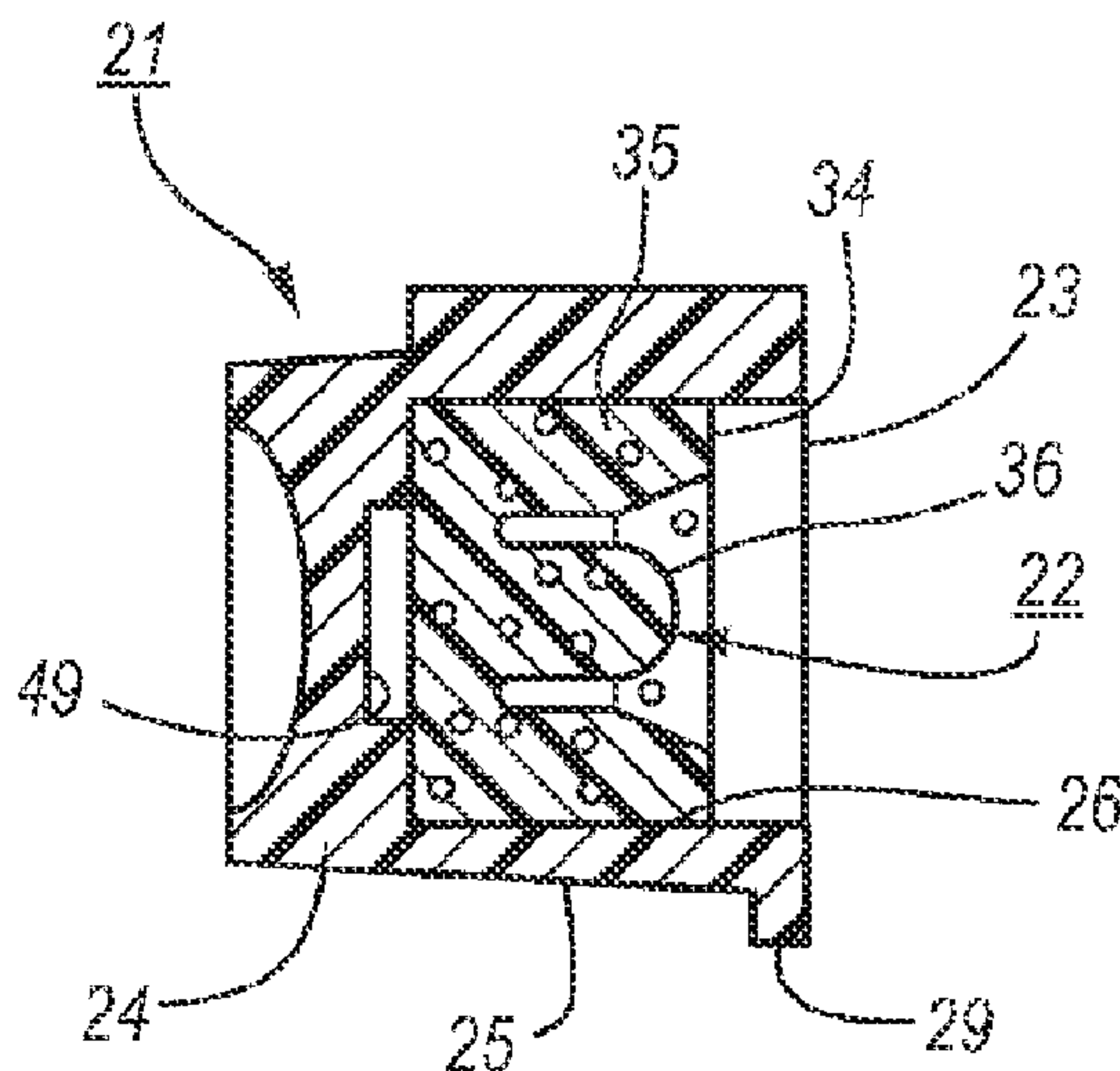

(86) **Date de dépôt PCT/PCT Filing Date:** 2010/04/01
 (87) **Date publication PCT/PCT Publication Date:** 2010/10/07
 (45) **Date de délivrance/Issue Date:** 2017/03/14
 (85) **Entrée phase nationale/National Entry:** 2011/09/28
 (86) **N° demande PCT/PCT Application No.:** US 2010/029641
 (87) **N° publication PCT/PCT Publication No.:** 2010/115005
 (30) **Priorité/Priority:** 2009/04/01 (US61/211,607)

(51) **Cl.Int./Int.Cl. A61L 2/16** (2006.01)
 (72) **Inventeurs/Inventors:**
 KERR, MARSHALL, US;
 VAILLANCOURT, MICHAEL J., US;
 BREITER, CATHERINE C., US
 (73) **Propriétaire/Owner:**
 C. R. BARD, INC., US
 (74) **Agent:** SMART & BIGGAR

(54) **Titre : DISPOSITIF DE NETTOYAGE MICROBIEN**
 (54) **Title: MICROBIAL SCRUBBING DEVICE**



(57) **Abrégé/Abstract:**

The microbial scrub brush in one embodiment employs an insert of foam material that is impregnated with an anti-bacterial disinfectant that is housed within a housing of alcohol compatible material and sealed over by a removable lid. The insert is maintained in sterile condition until ready for use. After the removal of the lid, the insert of foam material is moved over the end of a female luer or other portion of a medical device and rotated in order to clean the exterior surface as well as the interior luminal surface of the device. In one embodiment, the insert includes a plurality of resilient fingers that substantially occupy a cross sectional area of the cavity to enable the cleansing of both the exterior surface and an interior luminal surface of the medical device.

(12) INTERNATIONAL APPLICATION PUBLISHED UNDER THE PATENT COOPERATION TREATY (PCT)

(19) World Intellectual Property Organization
International Bureau(43) International Publication Date
7 October 2010 (07.10.2010)(10) International Publication Number
WO 2010/115005 A1(51) International Patent Classification:
A61L 2/16 (2006.01)

(21) International Application Number:

PCT/US2010/029641

(22) International Filing Date:

1 April 2010 (01.04.2010)

(25) Filing Language:

English

(26) Publication Language:

English

(30) Priority Data:

61/211,607

1 April 2009 (01.04.2009)

US

(71) Applicant (for all designated States except US): **C. R. BARD, INC.**; 730 Central Avenue, Murray Hill, NJ 07974 (US).

(72) Inventors; and

(75) Inventors/Applicants (for US only): **KERR, Marshall** [US/US]; 2984 Wintergreen Drive, Carlsbad, CA 92008 (US). **VAILLANCOURT, Michael, J.** [US/US]; 31 Cora Lane, Chester, NJ 07930 (US). **BREITER, Catherine, C.** [US/US]; 2919 Kentucky Avenue, Holladay, UT 84117 (US).(74) Agent: **WIGHT, Todd, W.**; Rutan & Tucker, LLP, 611 Anton Boulevard, Suite 1400, Costa Mesa, CA 92626 (US).

(81) Designated States (unless otherwise indicated, for every kind of national protection available): AE, AG, AL, AM, AO, AT, AU, AZ, BA, BB, BG, BH, BR, BW, BY, BZ, CA, CH, CL, CN, CO, CR, CU, CZ, DE, DK, DM, DO, DZ, EC, EE, EG, ES, FI, GB, GD, GE, GH, GM, GT, HN, HR, HU, ID, IL, IN, IS, JP, KE, KG, KM, KN, KP, KR, KZ, LA, LC, LK, LR, LS, LT, LU, LY, MA, MD, ME, MG, MK, MN, MW, MX, MY, MZ, NA, NG, NI, NO, NZ, OM, PE, PG, PH, PL, PT, RO, RS, RU, SC, SD, SE, SG, SK, SL, SM, ST, SV, SY, TH, TJ, TM, TN, TR, TT, TZ, UA, UG, US, UZ, VC, VN, ZA, ZM, ZW.

(84) Designated States (unless otherwise indicated, for every kind of regional protection available): ARIPO (BW, GH, GM, KE, LR, LS, MW, MZ, NA, SD, SL, SZ, TZ, UG, ZM, ZW), Eurasian (AM, AZ, BY, KG, KZ, MD, RU, TJ, TM), European (AT, BE, BG, CH, CY, CZ, DE, DK, EE, ES, FI, FR, GB, GR, HR, HU, IE, IS, IT, LT, LU, LV, MC, MK, MT, NL, NO, PL, PT, RO, SE, SI, SK, SM, TR), OAPI (BF, BJ, CF, CG, CI, CM, GA, GN, GQ, GW, ML, MR, NE, SN, TD, TG).

[Continued on next page]

(54) Title: MICROBIAL SCRUBBING DEVICE

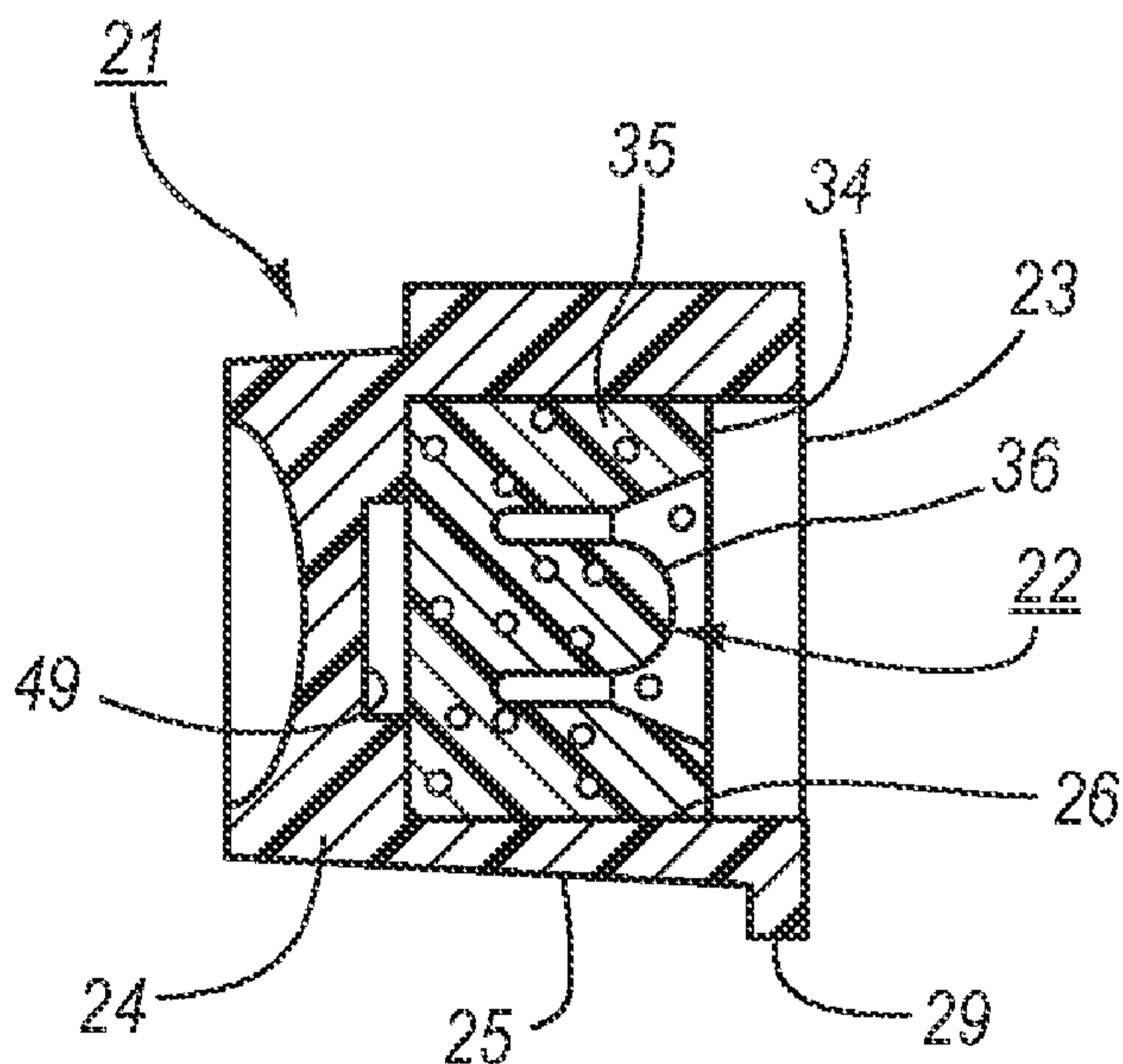
**Fig. 4**

(57) Abstract: The microbial scrub brush in one embodiment employs an insert of foam material that is impregnated with an anti-bacterial disinfectant that is housed within a housing of alcohol compatible material and sealed over by a removable lid. The insert is maintained in sterile condition until ready for use. After the removal of the lid, the insert of foam material is moved over the end of a female luer or other portion of a medical device and rotated in order to clean the exterior surface as well as the interior luminal surface of the device. In one embodiment, the insert includes a plurality of resilient fingers that substantially occupy a cross sectional area of the cavity to enable the cleansing of both the exterior surface and an interior luminal surface of the medical device.

WO 2010/115005 A1 

Published:

— *with international search report (Art. 21(3))*

76186-263

MICROBIAL SCRUBBING DEVICE**CROSS-REFERENCE TO RELATED APPLICATIONS**

[0001] This application claims the benefit of U.S. Patent Application No. 61/211,607, filed April 1, 2009, and entitled "Scrub Brush."

BRIEF SUMMARY

[0002] Briefly, embodiments of the invention employ a swab in the form of a piece of foam material that is impregnated with an anti-bacterial disinfectant and into which a female luer or the like may be inserted for cleaning upon rotation of the piece of foam material about the luer.

[0003] In addition, the swab is disposed within a housing that allows a user to manipulate the swab using the fingers of a hand. In this respect, the swab is secured, for example, by an adhesive, within the housing so that after insertion of a female luer into the swab, the housing and, thus, the swab can be rotated by the user about the surfaces of the luer. The housing is also provided with indicia to indicate to the user the number of full turns of the housing about a luer when in use.

[0004] After securement of the swab in the housing, a removable lid is placed on the housing in order to maintain the sterility of the swab prior to use.

[0005] In particular, embodiments of the invention provide a microbial scrub brush that is comprised of a housing that defines a cavity, an insert of foam material that is disposed in the cavity and an anti-bacterial disinfectant in the insert.

[0006] The housing is sized to be readily handled using two or three fingers of a hand. Further, the housing is sized so that a female luer may be readily inserted into the insert within the housing cavity.

[0007] In one embodiment, the insert is provided with an annular portion for enveloping an outer surface of the female luer as well as a central portion for insertion within a central passage of the female luer for sterilizing an interior of the female luer.

76186-263

[0008] The insert of foam material may be of any suitable material such as a semi-closed hydrophilic polyurethane medical grade foam. The foam material may also be a closed foam, an open foam or a semi-closed foam.

[0009] The anti-bacterial disinfectant may be of any suitable type and is in any
5 suitable amount depending upon the size of the insert of foam material. For example, use is made of an aqueous solution containing about two percent (2%) chlorhexidine gluconate (chlorhexidine Solution) in an amount of from about 0.20 cc to about 0.75 cc, such as about 0.50 cc in one embodiment.

[00010] The scrub brush is also provided with a lid to seal the cavity and insert from
10 the surrounding environment and to maintain the insert within the housing in a sterile condition and to keep the insert from drying out. The lid may also be provided with a pull tab to facilitate removal of the lid from the housing when the brush is to be used.

[00011] In normal operations, the lid is removed from the brush in order to expose the
15 end of the insert within the housing. The brush is then placed over an exposed female luer, *i.e.*, a needle-less connector, and rotated, for example for two complete revolutions. While rotating, the brush will self thread onto the female luer until the luer bottoms out. After completion, for example, of two full rotations, the brush can be removed from the luer by sliding the brush off the luer and discarded according to standard hospital protocol.

[00012] In one embodiment, the scrub brush includes an insert including a plurality of
20 resilient fingers that substantially occupy a cross sectional area of the cavity to enable the cleansing of both an exterior surface and an interior luminal surface of a medical device.

[00012a] Embodiments of the invention also provide a scrubbing device for cleansing a
portion of a medical device, comprising: a holder defining a cavity sized to receive therein the
portion of the medical device; and a cleansing insert disposed in the cavity and including a
25 plurality of resilient fingers capable of retaining a cleansing substance so as to cleanse both an exterior surface and an interior luminal surface of the portion of the medical device when the portion of the medical device is received in the cavity and the fingers are moved relative to the

76186-263

portion of the medical device, the fingers being defined by a plurality of cross-cut slits in a block of resilient material.

[00012b] Embodiments of the invention also provide a method for cleansing a portion of a medical device, the method comprising: providing a scrubbing device as described above;
5 inserting the portion of the medical device into the cavity; and moving the fingers with respect to the medical device so as to cleanse both exterior and interior surfaces of the portion of the medical device.

[00012c] Embodiments of the invention also provide a scrubbing device for cleansing a portion of a medical device, comprising: a holder defining a cavity including an open end for
10 receiving the portion of the medical device into the cavity; an insert disposed in the cavity of the holder, the insert including a base and a plurality of resilient fingers extending contiguously from the base, the fingers sized so as to engage an exterior surface and an interior luminal surface of the portion of the medical device, the fingers being defined by a plurality of cross-cut slits in a block of resilient material; and a cleansing substance included
15 with the fingers for cleansing the exterior surface and the interior luminal surface when the surfaces are engaged by the fingers.

[00012d] Embodiments of the invention also provide a scrubbing device for cleansing a portion of a medical device, comprising: a holder defining a cavity including an open end for receiving the portion of the medical device into the cavity; an insert disposed in the cavity, the
20 insert including a rolled sheet of material including a plurality of slits that define a plurality of fingers sized so as to engage the portion of the medical device, the fingers being defined by a plurality of cross-cut slits in a block of resilient material; and a cleansing substance included with the fingers for cleaning the portion of the medical device when the portion is engaged by the fingers.

25 **[00013]** These and other features of embodiments of the present invention will become more fully apparent from the following description and appended claims, or may be learned by the practice of embodiments of the invention as set forth hereinafter.

76186-263

BRIEF DESCRIPTION OF THE DRAWINGS

[00014] A more particular description of the present disclosure will be rendered by reference to specific embodiments thereof that are illustrated in the appended drawings.

It is appreciated that these drawings depict only typical embodiments of the invention and
5 are therefore not to be considered limiting of its scope. Example embodiments of

the invention will be described and explained with additional specificity and detail through the use of the accompanying drawings in which:

[00015] FIG. 1 illustrates a perspective view of a microbial scrub brush in accordance with one embodiment;

[00016] FIG. 2 illustrates an exploded view of the scrub brush of FIG. 1;

[00017] FIG. 3 illustrates a perspective view of the housing of the scrub brush of FIG. 2;

[00018] FIG. 4 illustrates a cross-sectional view of the scrub brush of FIG. 1;

[00019] FIG. 5 illustrates a detailed view of a surface of the housing of FIG. 4;

[00020] FIG. 6 illustrates a cross-sectional view of a modified housing in accordance with one embodiment;

[00021] FIG. 7 illustrates a perspective view of the insert of the scrub brush of FIG. 2;

[00022] FIG. 8 illustrates a view of a female luer being inserted into the insert of the scrub brush in accordance with one embodiment;

[00023] FIG. 9 illustrates a cross-sectional view of a modified insert in accordance with one embodiment;

[00024] FIG. 10 illustrates a cross-sectional view of a further modified insert in accordance with one embodiment;

[00025] FIG. 11 illustrates a cross-sectional view of a further modified insert in accordance with one embodiment;

[00026] FIG. 12 illustrates a cross-sectional view of an insert that is die cut in accordance with one embodiment;

[00027] FIG. 13 illustrates a cross-sectional view of a modified die-cut insert in accordance with one embodiment;

[00028] FIG. 14 illustrates a cross-sectional view of a further modified die-cut insert in accordance with one embodiment;

[00029] FIG. 15 illustrates a modified surface on the housing for receiving a closure lid;

[00030] FIG. 16 illustrates a side view of a modified housing in accordance with one embodiment;

[00031] FIG. 17 illustrates a rear closed end view of the housing of FIG. 16;

[00032] FIG. 18 illustrates a front open end view of the housing of FIG. 16;

[00033] FIG. 19 illustrates a perspective view of a foamed plastic insert in accordance with one embodiment;

[00034] FIG. 20A illustrates a perspective view of a foamed plastic insert in accordance with one embodiment;

[00035] FIG. 20B illustrates a perspective view of a foamed plastic insert in accordance with one embodiment;

[00036] FIG. 21 illustrates a top view of the insert of FIG. 19 in a holder of circular cross-sectional shape to form a scrub brush in accordance with one embodiment;

[00037] FIG. 22 illustrates a view of an externally threaded catheter in a position to be inserted and turned within the scrub brush of FIG. 21;

[00038] FIG. 23 illustrates a cross-sectional view of the scrub brush of FIG. 21 during rotation of the externally threaded catheter of FIG. 22 therein;

[00039] FIG. 24 illustrates a cross-sectional view of an externally threaded catheter and scrub brush at a point during rotation of the catheter in the foamed insert of the scrub brush;

[00040] FIG. 25 illustrates a perspective view of a sheet of material for use in a scrub brush in accordance with one embodiment;

[00041] FIG. 26 illustrates a perspective view of the sheet of FIG. 25 in a rolled-up and slit configuration to define an insert of the scrub brush; and

[00042] FIG. 27 illustrates a cross sectional side view of a holder of a scrub brush including the rolled up and slit sheet of FIG. 26 disposed in a cavity of the holder, according to one embodiment.

DETAILED DESCRIPTION OF SELECTED EMBODIMENTS

[00043] Reference will now be made to figures wherein like structures will be provided with like reference designations. It is understood that the drawings are diagrammatic and schematic representations of exemplary embodiments of the present invention, and are neither limiting nor necessarily drawn to scale.

[00044] For clarity it is to be understood that the word “proximal” refers to a direction relatively closer to a clinician using the device to be described herein, while the word “distal” refers to a direction relatively further from the clinician. For example, the end of a catheter placed within the body of a patient is considered a distal end of the catheter, while the catheter end remaining outside the body is a proximal end of the catheter. Also, the words “including,” “has,” and “having,” as used herein, including the claims, shall have the same meaning as the word “comprising.”

[00045] Referring to FIGS. 1 and 2, the microbial scrub brush 20 is comprised of a housing 21, a swab in the form of an insert 22 and a lid 23.

[00046] Referring to FIGS. 3 and 4, the housing 21 is of one piece in a cup shape and is formed of a base 24 and a ring 25 integral with the base 24 to define a cavity 26 of cylindrical shape with an open end. The housing 21 is made by injection molding and is made of an alcohol compatible material, such as polypropylene or polyethylene, for instance.

[00047] As indicated in FIG. 4, the cavity 26 is coaxial of the longitudinal axis of the housing 21. The overall dimensions of the housing 21 are such that the housing 21 may be readily handled and rotated using two or three fingers of a hand. For example, the housing 21 may have an outside diameter of 0.725 inches and a length of 0.650 inches. In another embodiment, the housing includes an outside diameter of about 0.75 inches and a length of about 0.90 inches. Of course, other housing dimensions are possible, in accordance with the nature of intended use.

[00048] Referring to FIG. 3, the housing 21 has a plurality of ribs 27 of the exterior surface of the ring 25 to provide a gripping surface. Any other suitable type of knurling may also be used. The housing 21 may also contain a plurality of ribs 28 on the interior surface of the ring 25 that extend into the cavity 26 in order to engage the insert 22 (not shown) to prevent the insert 22 from rotating within the cavity 17.

[00049] Optionally, the insert 22 may be adhesively secured against rotation within the housing 21.

[00050] Referring to FIG. 4, the housing 21 is provided with an indicia, for example in a form of a projecting index bar 29, on the exterior surface in order to indicate a degree of rotation of the housing 21 when in use and, particularly, the number of rotations that the brush 20 is turned during use.

[00051] Referring to FIG. 5, the housing 21 has an annular boss 30 at one end concentric to the cavity 26 for heat sealing of the lid 23 thereon. In this respect, the lid 23 is a die-cut foil lid that is coated with a material that readily heat seals to the polypropylene housing 21 via the boss 30. As indicated in FIG. 1, the lid 23 is provided with a pull tab 31 that extends therefrom and from the housing 21 in order to facilitate manual removal of the lid 23 from the housing 21.

[00052] Referring to FIG. 6, wherein like reference characters indicate like parts as above, the housing 21' may also be made in a two-piece construction. For example, the housing 21' includes a base 24' that receives a ring 25' in a fixed relation. As indicated, the base 24' has a shouldered annular portion 32 that receives the ring 25' in a recessed manner so that a smooth outer surface is presented by the base 24' and ring 25'.

[00053] In addition, the ring 25' is provided with an inwardly directed lip 33 at an end opposite the base 24' in order to retain an insert 22 (not shown) therein.

[00054] Referring to FIGS. 4 and 7, the insert 22 is a foam material, for example, of injection molded construction or the insert 22 may be die-cut from a foam sheet. The insert 22 is mounted in the housing 21 to be exposed to the open end of the housing 21.

[00055] The distal end 34 of the insert 22 is flat and slightly recessed within the open end of the housing 21 and the proximal end of the insert 22 is flat and can be secured by

way of a suitable adhesive onto the base 24 of the housing 21. Typically, the insert 22 has an outer diameter of 9/16 inch (0.5625 inches).

[00056] The insert 22 includes an annular portion 35 and a central portion 36 with a flat end within the annular portion 35. The flat end of the central portion 36 may be coplanar with the end of the annular portion 35 as indicated in FIG. 7 or may be recessed within the annular portion 35 as indicated in FIGS. 4 and 8.

[00057] As illustrated in FIG. 8, the insert two portions 35, 36 are circumferentially spaced apart to define an annular gap 37 therebetween. In addition, the annular portion 35 has a conical inwardly directed surface 38 that provides a narrowing entrance to the gap 37 for a female luer 40 while the central portion 36 has an outer conical surface 39 that is formed with a 6% taper for engagement with the taper of the female luer 40.

[00058] The exterior of the insert 22 may be formed to match and interlock with the internal ribs 28 of the housing 21 (see FIG. 3) to prevent rotation of the insert 22 within the housing 21.

[00059] The insert 22 is made of a semi-closed cell, hydrophilic polyurethane medical grade foam with a moderate absorption rate. The foam configuration and size is such as to hold 0.5 cc of an anti-bacterial solution with no solution leak-out.

[00060] During assembly of the scrub brush 20, the insert 22 is first secured within the housing 21 and then impregnated with the anti-bacterial solution. Thereafter, the lid 23 is secured to the housing 21.

[00061] Referring to FIG. 8, the insert 22 is sized to be used with a female luer 40 having an outer peripheral surface 41, a central passage 42 and a flange 43 about the passage 42. As indicated, the annular portion 35 of the insert 22 is sized to envelope and wipe the outer surface 41 of the female luer 40 and the central portion 36 is sized to move into the passage 42 of the female luer 40 for wiping the passage 42.

[00062] In normal operation, the lid 23 is removed to expose the insert 22 and the brush 20 is placed over the female luer 40 with the luer 40 inserted into the gap 37 between the two portions 35, 36 of the insert 22. The conical entrance portion 38 of the insert 22 facilitates centering of the brush 20 on the luer 40.

[00063] Next, the brush 20 is rotated. The rotation of the brush 20 causes a self-threading of the insert 22 into the passage 42 of the luer 40 until the luer 40 bottoms at the base of the gap 37 defined by the annular portion 35 and the central portion 36 of the insert 22. Typically, the brush 20 is rotated 360 degrees twice. Upon completion of two full rotations, the brush 20 can be removed by sliding the brush 20 off the luer 40 and discarded.

[00064] The housing 21 of the scrub brush 20, when sealed by the lid 23, protects against drying out of the insert 22 and after removal of the lid 23 serves as a convenient holder for wiping of the insert 22 about a female luer or the like.

[00065] Referring to FIG. 9, wherein like reference characters indicate like parts as above, the central portion 36 of the insert 22' may be provided with a rounded end or crown 44 rather than a flat surface as indicated in FIG. 8. The rounded crown 44 is particularly useful where the scrub brush 20 is used to clean a swabable luer having a flat end or the like (not shown). In this case, the peak of the crown 44 would first contact the flat end of the swabable luer in a point-to-point manner. Then, as the brush 20 is further pushed against the luer, the crown 44 would compress thereby compressing the central portion 36 of the insert 22'. As the brush is then rotated, a scrubbing action takes place between the surface of the now compressed central portion 36 and the luer surface.

[00066] Referring to FIG. 10, wherein like reference characters indicate like parts as above, the insert 22" may be constructed without a gap between the annular portion 35 and central portion 36. In this embodiment, the two portions 35, 36 are contiguous to each other and define a slit 45 rather than a gap for receiving a luer. Further, the central portion 36 is co-extensive with the annular portion 35, *i.e.*, the central portion 36 is not recessed, and is provided with a conically tapered surface 46 at the entrance end to the slit 45 to provide a small gap with the annular portion 35.

[00067] Referring to FIG. 11, wherein like reference characters indicate like parts as above, the insert 22'" may be constructed with an annular gap 37 between the annular portion 35 and central portion 36 that extends for the full depth of the central portion 36 without a conical entrance portion as in FIG. 8.

[00068] Referring to FIG. 12, wherein like reference characters indicate like parts as above, the insert 47 is die cut to form a slit 45 with the two portions 35, 36 contiguous to

each other. As illustrated, the slit 45 extends from the face of the insert 47 and terminates short of the rear end of the insert 47. Alternatively, the slit 45 may extend completely through the insert 47' as shown in FIG. 13. Also, the central portion 36 may be pushed relative to the annular portion 35 so as to extend beyond the annular portion 36 as shown in FIG. 14. In this latter case, the exposed rear end 48 of the central portion 36 may extend into a recess 49 formed in the base 24 of the housing 21 (see FIG. 4) and be secured therein by an adhesive.

[00069] Referring to FIG. 15, wherein like reference characters indicate like parts as above, the housing ring 25 may be formed with a flat surface 50 that is textured in order to receive an adhesive for securing the lid 23 (see FIG. 4) in place or the lid 23 may be heat sealed in place.

[00070] Referring to FIGS. 16 to 18, wherein like reference characters indicate like parts as above, the housing 51 may be made with a polygonal outer cross-section, such as a hexagonal cross-section, to provide a plurality of contiguous flat surfaces 52 for easier gripping by the fingers of a user's hand. These surfaces 52 may be textured or roughened to facilitate gripping. Also, one or more of the flat surfaces may be provided with indicia, such as a logo of the manufacturer or the like.

[00071] The housing 51 has a short flange 53 at the open end that is also provided to form a surface 50 for receiving a lid 23 as described above.

[00072] In addition, the housing 51 has a cavity 26 that is of a polygonal shape complementary to the outer cross-section to provide a plurality of flat walls 54. The cavity 26 and walls 54 are sized to receive the insert 22 in a compressed condition. That is, for a cylindrical insert 22 of 9/16 inch diameter, the oppositely disposed walls 54 are spaced apart by 0.500 inches and the oppositely disposed corners 55 formed by the walls 54 are spaced apart 0.553 inches. The insert 22 is, thus, circumferentially compressed within the cavity 26.

[00073] When a luer is inserted into the insert 22 in the housing 51, the degree of compression imposed upon the insert 22 when placed in the housing 51 causes the insert to wipe the surfaces of the luer with a scrubbing action.

[00074] The scrub brush 20 may be modified in various manners. For example, where the device being cleaned does not have a central passage, the insert 22 of the scrub brush 20 may be made without a central portion 36. In this embodiment, the scrub brush would be placed over the end of the device and then rotated so as to thread the scrub brush onto the end of the device for disinfecting purposes. Also, in this embodiment, having the insert mounted in the housing in a circumferentially compressed manner would facilitate the disinfecting action of the scrub brush on the device.

[00075] Embodiments of the invention thus provide a device that is easily handled and that is able to disinfect a female luer in an easy manner. Further, embodiments of the invention provide a device that is able to disinfect the interior of a female luer. This is a particular advantage over a cloth type wipe that cannot be readily inserted into the passage of a female luer.

[00076] Embodiments of the invention further provide an insert that is impregnated with an anti-bacterial solution for decontamination of a luer site that is contained in a sterile condition until ready for use and that can be readily manipulated when in use.

[00077] FIGS. 19-27 depict further details regarding a microbial scrubbing device in accordance with embodiments of the present invention. As many of the features described above may be included in the scrubbing devices to be discussed below, only selected features are included in the following discussion. As such, the following discussion should not be intended to limit the scope of the embodiments described herein.

[00078] Referring to FIG. 19, the foamed plastic insert 110 includes a cubic shape. In addition, the insert 110 is digitated, *i.e.*, is cross-cut with slits 111 in each of two perpendicular directions to form separate parallel fingers 112 of rectangular cross-sectional shape. The slits 111 extend downwardly a major fraction of the height of the insert 110, *e.g.*, about $\frac{3}{4}$ of the height of the insert 110 so that the fingers 112 extend integrally and upwardly from a common base 113 of rectangular cross-sectional shape. As illustrated, the slits 111 are spaced apart to define a 4-by-4 grid of fingers 112.

[00079] In one embodiment, the foam insert 110 includes a length of $\frac{5}{8}$ inch, a width of $\frac{5}{8}$ inch and a height of $\frac{3}{4}$ inch. Note, however, that the length of the fingers as well as the size and shape of the foamed insert can vary from what is explicitly described

herein. For instance, instead of including a square cross sectional shape, the fingers in one embodiment can include a triangular, round or other polygonal shape.

[00080] Note that in one embodiment the insert 110 includes a semi-closed cell, hydrophilic polyurethane medical grade foam in the present embodiment. In another embodiment, the insert 110 includes a low density, closed cell polyethylene foam. It is appreciated that the insert 110 in other embodiments can include other suitable materials. Characteristics of a suitable material include sufficient deformability, ability to retain a cleansing substance such as an antibacterial solution, suitable resistance to tearing or separation, and stability in the presence of the cleansing substance. In one embodiment, a closed cell material including sufficient surface tension to suspend the cleansing substance on the surface of the fingers can be employed. In other embodiments, closed cell polyurethane, semi-closed or open celled polyurethane, silicone, polyethylene, and a thermoplastic elastomer including rubber and polypropylene sold under the name SANTOPRENE, among other suitable substances, can be employed to form the insert.

[00081] Further, in one embodiment it is appreciated that the insert can include two or more materials included together to provide different regions with differing scrubbing characteristics, *e.g.*, differing abrasive characteristics. These and other modifications to the insert are therefore contemplated.

[00082] Referring to FIGS. 20A and 20B, wherein like reference characters indicate like parts as above, the foamed insert may have slits 111 that define a different number of fingers 112, *i.e.*, a 3-by-3 grid of fingers 112 in the insert 110', or a 5-by-5 grid of fingers 112 in the insert 110''. Any suitable number of fingers 112 may be formed in an insert 110 with the spacing of the slits 111 being adapted to the number and/or size of the fingers 112 desired for the insert 110 and the use to which the insert 110 is to be subjected. It is further appreciated that the shape and size of the insert can vary according to shape, size, and number of fingers included therewith.

[00083] Referring to FIG. 21, wherein like reference characters indicate like parts as above, the insert 110 is placed in a holder 114 of hexagonal cross-sectional shape to form a scrub brush 115 similar to the scrub brush described in previous embodiments further above. The holder 114 is sized with the opposite interior walls (flats) spaced $\frac{1}{2}$ inch apart so that the insert 110 is compressed, particularly at the corners, when fitted into the cavity of the holder 114 as indicated in FIG. 21. A suitable hot melt glue or other

76186-263

suitable adhesive may be used to adhere the insert 110 to the bottom of the holder 114. Of course, other suitable methods can be employed to secure the insert 110 to the holder 114, including mechanical fixation for instance. In one embodiment, the compression provided by the holder once the insert is inserted therein is sufficient to maintain the insert in position within the holder.

[00084] As indicated in FIG. 22, the cavity of the holder 114 includes a depth suitable to receive the insert 110 in a recessed manner. So disposed within the holder 114, the insert 110 in the present embodiment substantially fills the cavity of the holder. In other embodiments, the insert can be sized so as to fill the holder cavity to depths different from that shown here.

[00085] The insert 110, when disposed in the cavity of the holder 114, substantially occupies a cross sectional area of the cavity, as best seen in FIG. 21. This enables the fingers to be disposed across a cross sectional area sufficient to clean both exterior and interior surfaces of a portion of a medical device inserted into the holder 114. It is appreciated that the holder and the cavity it defines can assume other shapes, including square, round, etc. Indeed, the holder, its cavity, and the insert disposed therein can be configured in shape and size so as to enable the scrub brush 115, as a scrubbing device, to cleanse a particular size and configuration of a medical device.

[00086] As in previous embodiments a cleansing substance, such as a solution of a suitable microbicide or germicide, is impregnated into the insert 110 while in the holder 114. The cleansing substance can include an anti-bacterial disinfectant of any suitable type and suitable amount depending upon the size of the insert of foam material. For example, in one embodiment use is made of an aqueous solution including about two percent (2%) chlorhexidine gluconate (chlorhexidine solution, "CHG") by volume in an amount of from about 0.20 cc to about 0.75 cc. Optionally, a solution including about 0.50 cc is employed. In another embodiment, a solution including about 70 percent (70%) isopropyl alcohol ("IPA") in an aqueous solution is included in the cleansing substance. In yet another embodiment, a solution including about 70 percent (70%) IPA and about two percent (2%) CHG in an aqueous solution in an amount of about 0.2 ml is included in the cleansing substance. In the latter solution, it is recognized that the concentration of IPA can vary from about 60 percent (60%) to about 90 percent (90%)

76186-263

and the concentration of CHG can vary from about one percent (1%) to about five percent (5%), in one embodiment.

[00087] Other suitable solution compositions and concentrations are also possible. For instance, povidone iodine or hydrogen peroxide solutions can be included in the cleansing substance, in one embodiment.

[00088] In the case where it is a liquid, desired characteristics for the cleansing substance include a solution including suitable surface tension so as to be retained by the fingers and enable cleansing contact with the medical device portion to be cleansed.

[00089] Referring to FIG. 23, wherein like reference characters indicate like parts as above, the holder 114 includes an annular lip 116 around the tip edge to define a land for receiving a sealing membrane (not shown) that seals the interior of the holder 114 and the solution-impregnated insert 110 therein against contamination from the outside environment until the scrub brush 115 is to be used.

[00090] Note that, in one embodiment, the scrub brush 115 may be provided with the cleansing substance, including a **microbiocide** or germicide for instance, at the point and time of use by injecting or otherwise introducing the cleansing substance or germicide after the sealing membrane has been removed from the holder 114.

[00091] In one embodiment, use of the scrub brush 115 as a scrubbing device proceeds as follows: after removal of the sealing membrane by a user, the object to be cleaned, *e.g.*, a portion of an externally threaded hollow catheter 117, or a female type luer connector, is inserted by the user into the foamed insert 110. At this time, as indicated in FIG. 23, the fingers 112 of the insert 110 directly under the surfaces of the inserted portion of the catheter 117 are depressed into the holder 114, the fingers located outside the periphery of the catheter remain upright and lay against the outer peripheral surface of the catheter portion, and the fingers located directly under the lumen (bore) of the catheter pass into the lumen. The separate reactions of the fingers 112 are facilitated by the fingers 112 being formed in a digitated manner to be separated from each other as described above.

[00092] Once the portion of the catheter 117 has been inserted into the foamed insert 110 of the scrub brush 115, the holder 114 is rotated relative to the catheter portion. For

76186-263

example, the user may hold the catheter 117 stationary while rotating the scrub brush 115 or vice versa. In either case, the scrub brush 115 is rotated a sufficient number of times relative to the catheter 117 to sufficiently kill any bacteria the solution-impregnated foam insert 110 comes in contact with and/or to remove any biofilm from the outside peripheral surface and external thread as well as the inside surface of the lumen (bore) of the catheter 117, for example as described in US Patent Application Serial No. 12/079,965, filed March 31, 2008. In this way, both exterior surfaces and interior luminal surfaces of the portion of the catheter 117 are scrubbed by the respective fingers 112 of the insert 110, causing the cleansing substance carried by the fingers to disinfect the surfaces and remove any biofilm disposed thereon. Note that in one embodiment, a series of from about six to about ten rotations of the scrub brush 115 relative to the catheter 117 is suitable for cleansing the aforementioned surfaces. In other embodiments, other numbers of rotations are possible. In yet another embodiment, a back-and-forth twisting motion is employed to scrub the fingers against the medical device portion being cleansed. In the latter case, a series of eight back-and-forth twists is employed, according to one embodiment, though other numbers of twists or uni-directional/multi-directional motions are, of course, possible.

[00093] Referring to FIG. 24, wherein like reference characters indicate like parts as above, when the catheter 117 is inserted into the foamed insert 110, the fingers 112 that pass into a lumen 118 of the catheter 117 are slightly compressed due in part to the frictional forces between the interior luminal wall of the lumen 118 and the fingers 112 in contact therewith. The degree of compression is such as to enhance the degree of contact between the fingers 112 and the luminal wall of the lumen 118 and thus enhance the scrubbing action of the fingers 112 on the luminal wall. It is appreciated that the same scrubbing enhancement is realized on fingers in contact with exterior portions of the catheter 117 and other suitable portions of medical devices cleansed by the scrub brush, including a female-type luer connector, for instance.

[00094] As indicated in FIG. 24, the medical device, such as a male or female luer, standard or needleless connector, or other object to be inserted in the scrub brush 115, may have any suitable peripheral shape or contour for its exterior surface, as well as any suitable interior luminal surface or lumen 118. The lumen 118 may be of conically

76186-263

tapered shape, as illustrated, or may be of uniform diameter. In another embodiment, no interior luminal surface is included.

[00095] FIGS. 25-27 depict various details regarding a scrubbing device including an insert configured according to one embodiment. In particular, a sheet 200 of suitable material shown in FIG. 25 is rolled into a rolled-up configuration, as shown in FIG 26, to define an insert 210. A plurality of slits 211 is cut into the rolled sheet 200 a predetermined distance to define a plurality of fingers 212. As shown in FIG. 27, the rolled-up insert 210 can be inserted into the cavity of the holder 114 of the scrub brush 115, with a suitable cleansing substance added thereto.

[00096] The sheet 200 can include any one of a variety of suitable materials, including polyurethane foam, polyethylene foam, polyester, or other suitable natural or synthetic materials. Further, the material defining the sheet 200 can include a homogeneous, woven, knit, fibrous, or non-woven configuration, among others. In the case of fibrous materials, the fibers of the material are aligned parallel with the slits in one embodiment in order to impart suitable tear resistance to the fingers.

[00097] Embodiments of the invention may be embodied in other specific forms without departing from the scope of the present disclosure. The described embodiments are to be considered in all respects only as illustrative, not restrictive. The scope of the embodiments is, therefore, indicated by the appended claims rather than by the foregoing description. All changes that come within the meaning and range of equivalency of the claims are to be embraced within their scope.

76186-263

CLAIMS:

1. A scrubbing device for cleansing a portion of a medical device, comprising:
a holder defining a cavity sized to receive therein the portion of the medical device; and
5 a cleansing insert disposed in the cavity and including a plurality of resilient fingers capable of retaining a cleansing substance so as to cleanse both an exterior surface and an interior luminal surface of the portion of the medical device when the portion of the medical device is received in the cavity and the fingers are moved relative to the portion of the medical device, the fingers being defined by a plurality of cross-cut slits in a block of resilient
10 material.
2. The scrubbing device as defined in claim 1, wherein the cleansing insert includes a base portion from which the fingers extend.
3. The scrubbing device as defined in claim 1, wherein the fingers are aligned with one another and wherein the fingers include at least one of a hydrophilic polyurethane
15 and a polyethylene foam.
4. The scrubbing device as defined in claim 1, wherein the cleansing substance is pre-loaded into the fingers and includes a microbiocide in solution.
5. The scrubbing device as defined in claim 4, wherein the microbiocide in solution includes at least one of chlorhexidine gluconate and isopropyl alcohol.
- 20 6. The scrubbing device as defined in claim 5, wherein the microbiocide in solution includes at least two percent by volume of chlorhexidine gluconate.
7. The scrubbing device as defined in claim 1, wherein the fingers substantially occupy a cross sectional area of the cavity.

76186-263

8. The scrubbing device as defined in claim 1, wherein the cleansing insert includes a first plurality of fingers comprising a first material and a second plurality of fingers comprising a second material.

9. The scrubbing device as defined in claim 1, wherein the holder defines a
5 polygonal shape, and wherein the holder further includes a cap to cover an opening to the cavity defined by the holder.

10. A method for cleansing a portion of a medical device, the method comprising:
providing a scrubbing device according to any one of claims 1 to 9;
inserting the portion of the medical device into the cavity; and

10 moving the fingers with respect to the medical device so as to cleanse both exterior and interior surfaces of the portion of the medical device.

11. The method for cleansing as defined in claim 10, wherein inserting the portion of the medical device into the cavity further comprises:

15 inserting the portion of the medical device into the cavity such that a compressive engagement of the fingers is achieved between the fingers and the portion of the medical device.

12. The method of cleansing as defined in claim 10, wherein inserting the portion of the medical device into the cavity further comprises:

20 inserting the portion of the medical device into the cavity such that at least one of the fingers compressively engage an interior luminal surface of the portion of the medical device and such that a plurality of fingers compressively engage with an exterior surface of the portion of the medical device.

13. The method for cleansing as defined in claim 10, wherein moving the fingers with respect to the medical device further comprises:

76186-263

rotating the holder relative to the medical device such that the fingers are scrubbed against the portion of the medical device.

14. The method for cleansing as defined in claim 13, wherein rotating the holder further comprises:

5 rotating the holder sufficient to remove a biofilm from the portion of the medical device with the fingers of the scrubbing device.

15. A scrubbing device for cleansing a portion of a medical device, comprising:

a holder defining a cavity including an open end for receiving the portion of the medical device into the cavity;

10 an insert disposed in the cavity of the holder, the insert including a base and a plurality of resilient fingers extending contiguously from the base, the fingers sized so as to engage an exterior surface and an interior luminal surface of the portion of the medical device, the fingers being defined by a plurality of cross-cut slits in a block of resilient material; and

15 a cleansing substance included with the fingers for cleansing the exterior surface and the interior luminal surface when the surfaces are engaged by the fingers.

16. The scrubbing device as defined in claim 15, wherein a cross sectional shape of a plurality of the fingers is at least one of square, round, triangular, and polygonal.

17. The scrubbing device as defined in claim 16, wherein the fingers are compressed by at least one of an inner wall of the holder and the portion of the medical device
20 when the portion of the medical device is inserted in the cavity.

18. The scrubbing device as defined in claim 17, wherein the cavity defines a substantially round or polygonal volume and wherein the insert defines a substantially square shape such that the insert is deformed upon placement within the cavity, and wherein the insert substantially fills the volume of the cavity.

76186-263

19. The scrubbing device as defined in claim 18, wherein the insert includes polyurethane foam and wherein the fingers are arranged in a 5-by-5 grid.

20. A scrubbing device for cleansing a portion of a medical device, comprising:

5 a holder defining a cavity including an open end for receiving the portion of the medical device into the cavity;

an insert disposed in the cavity, the insert including a rolled sheet of material including a plurality of slits that define a plurality of fingers sized so as to engage the portion of the medical device, the fingers being defined by a plurality of cross-cut slits in a block of resilient material; and

10 a cleansing substance included with the fingers for cleaning the portion of the medical device when the portion is engaged by the fingers.

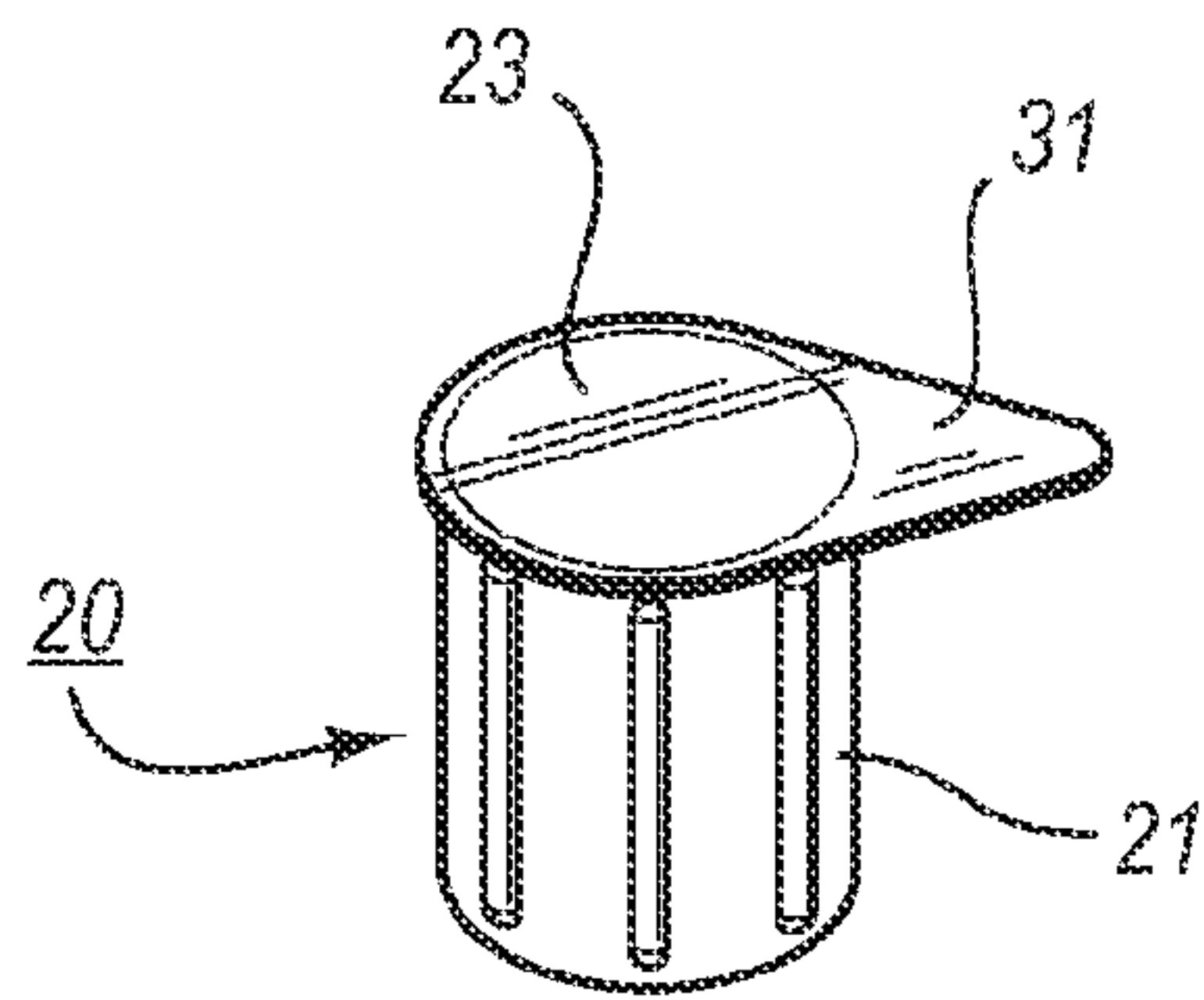

Fig. 1

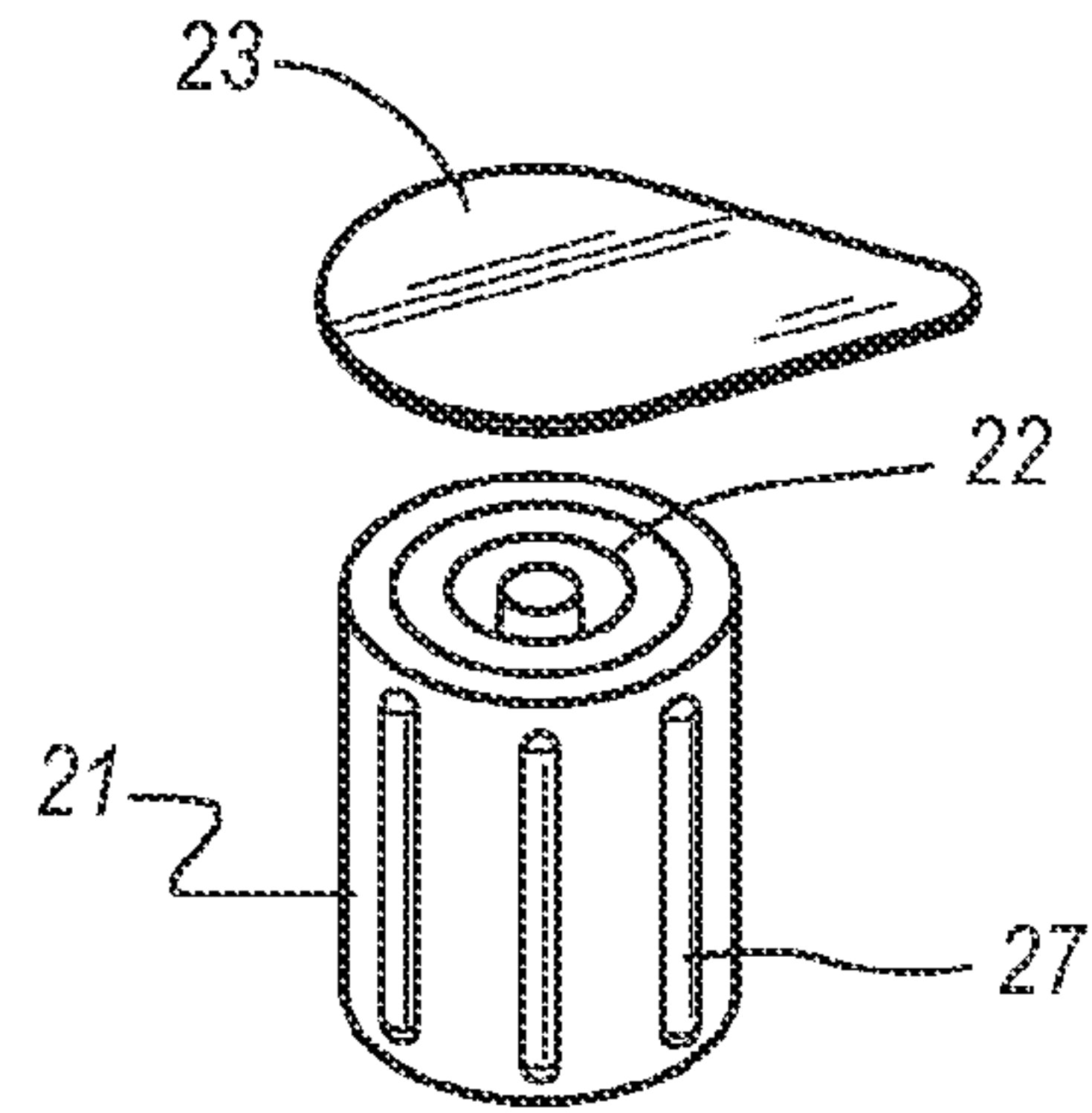

Fig. 2

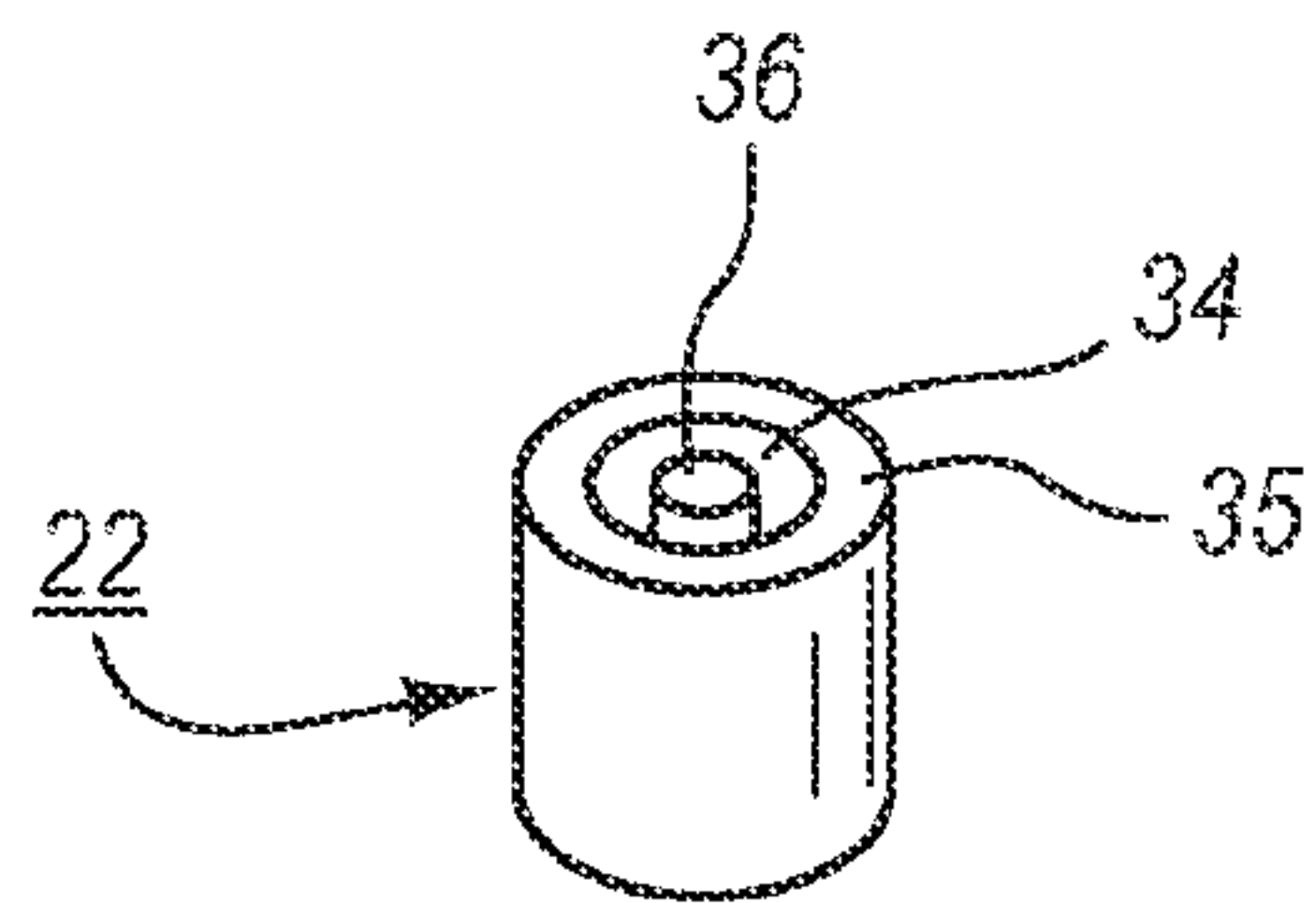

Fig. 7

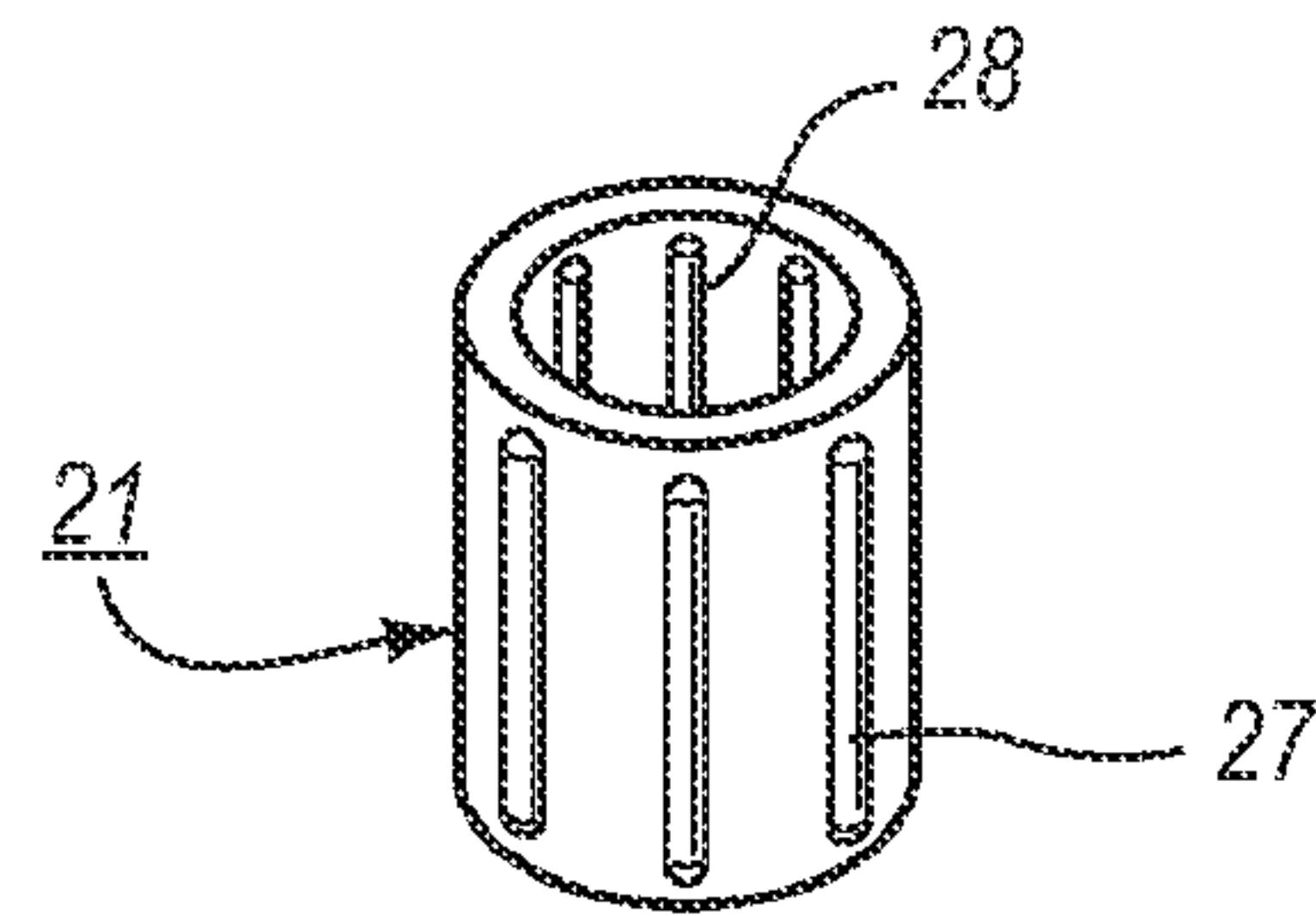

Fig. 3

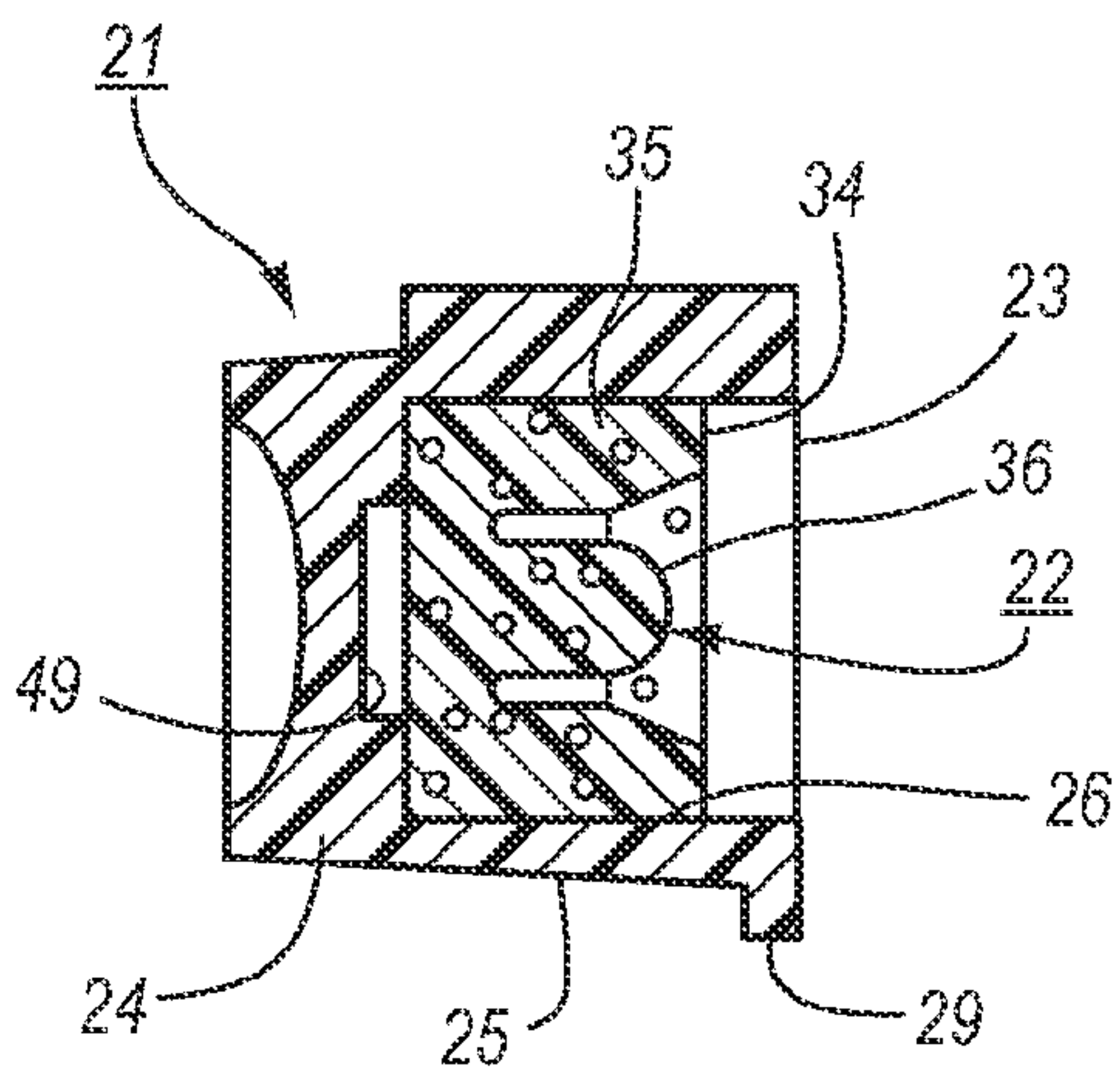

Fig. 4

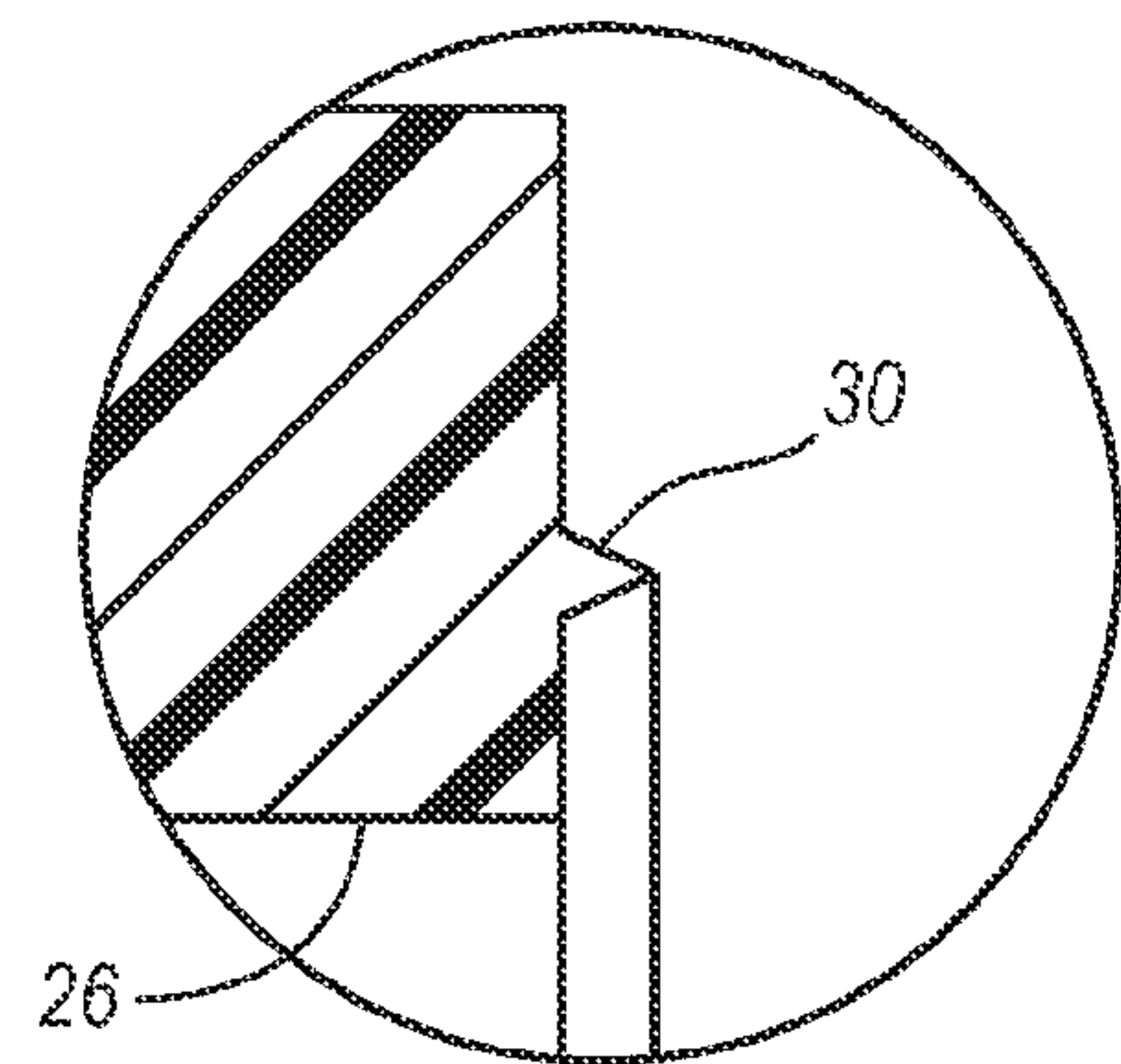

Fig. 5

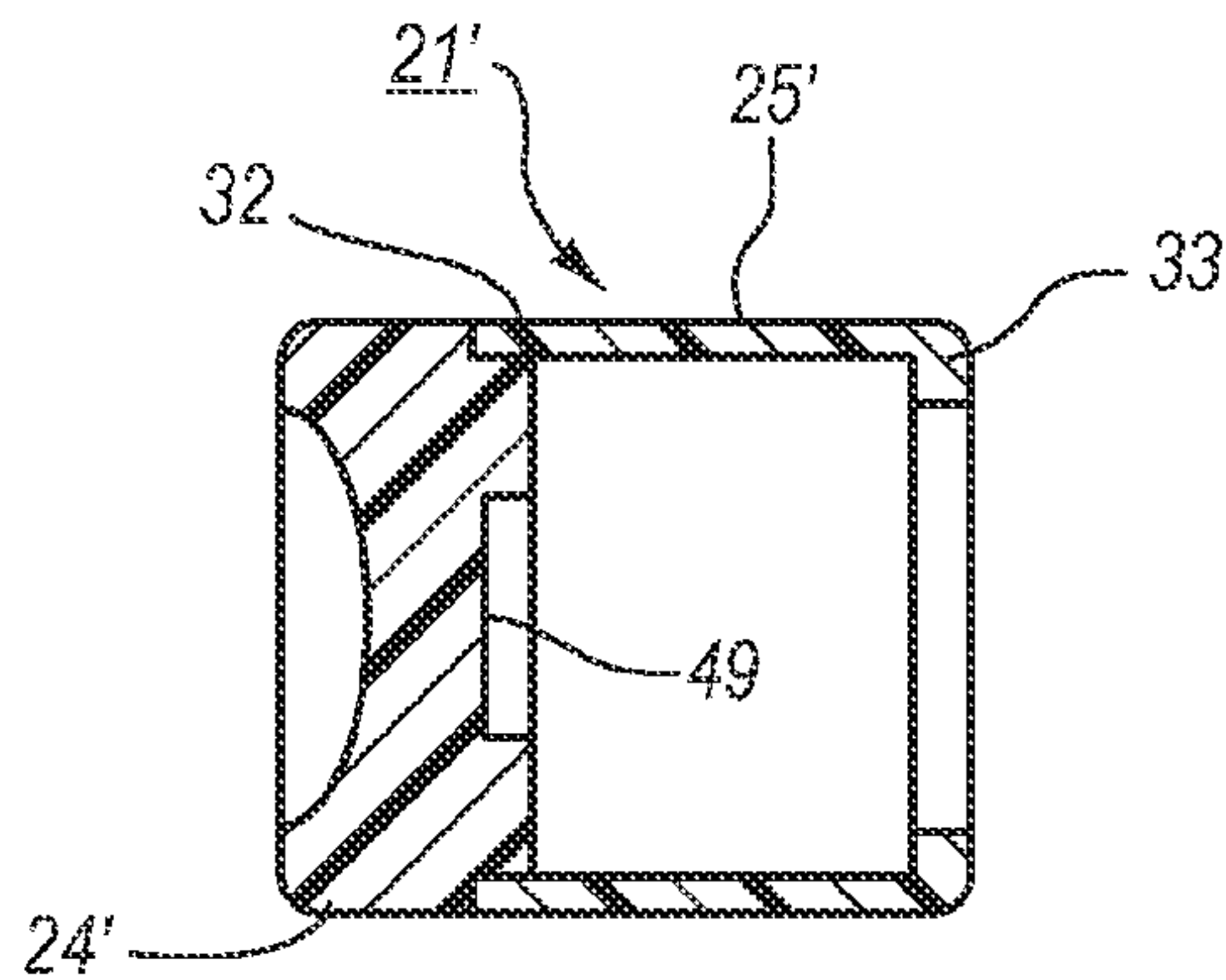

Fig. 6

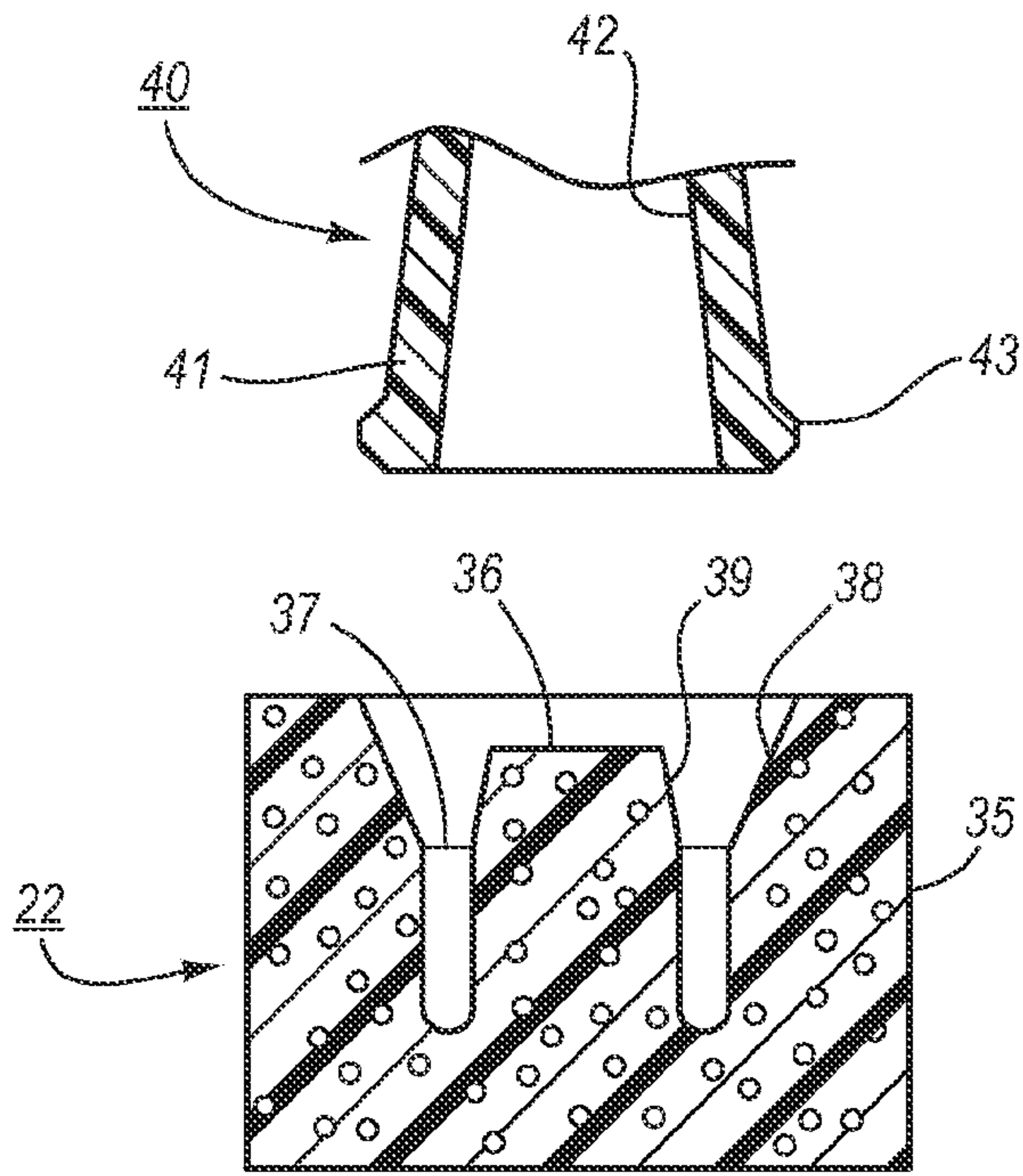

Fig. 8

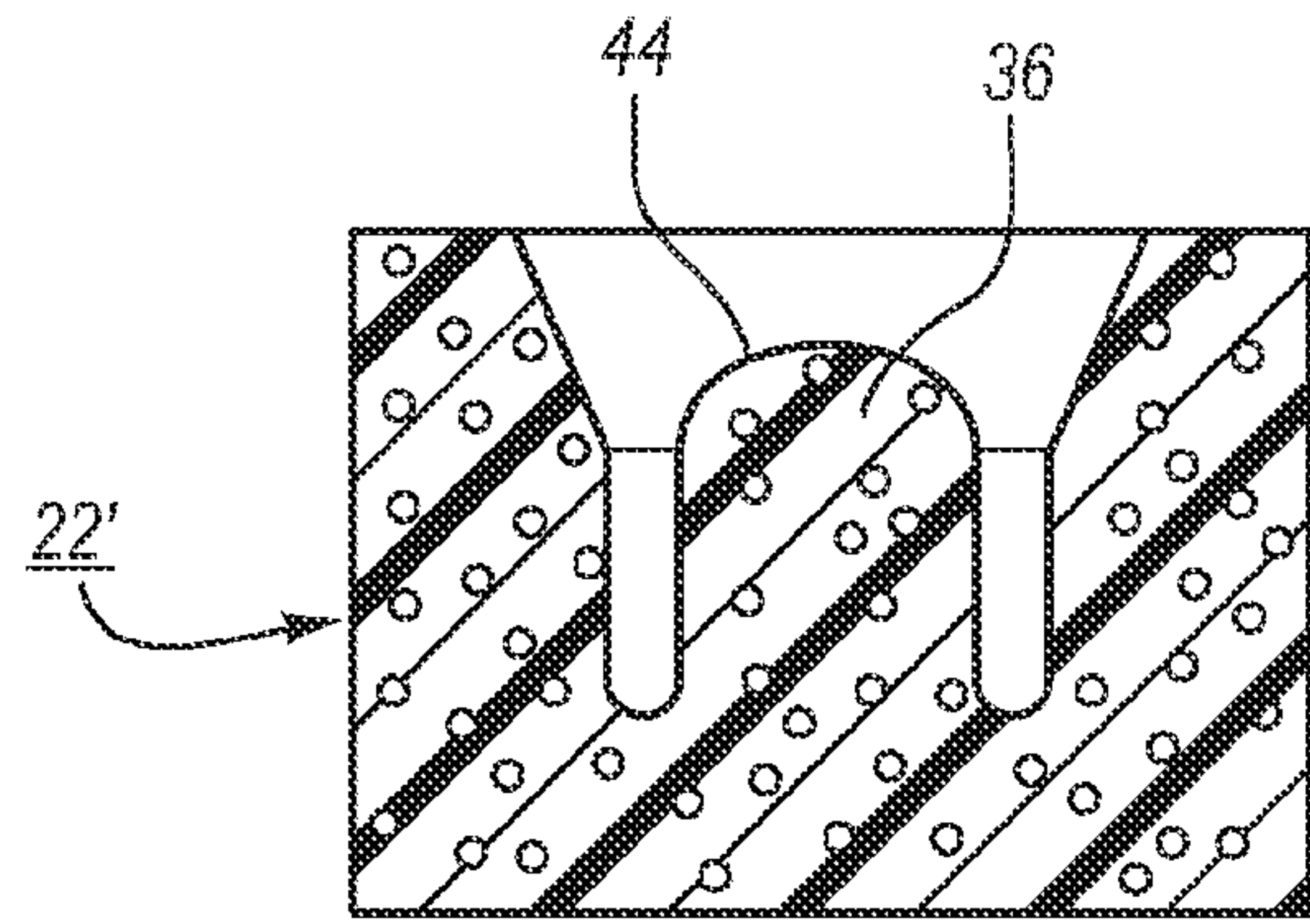

Fig. 9

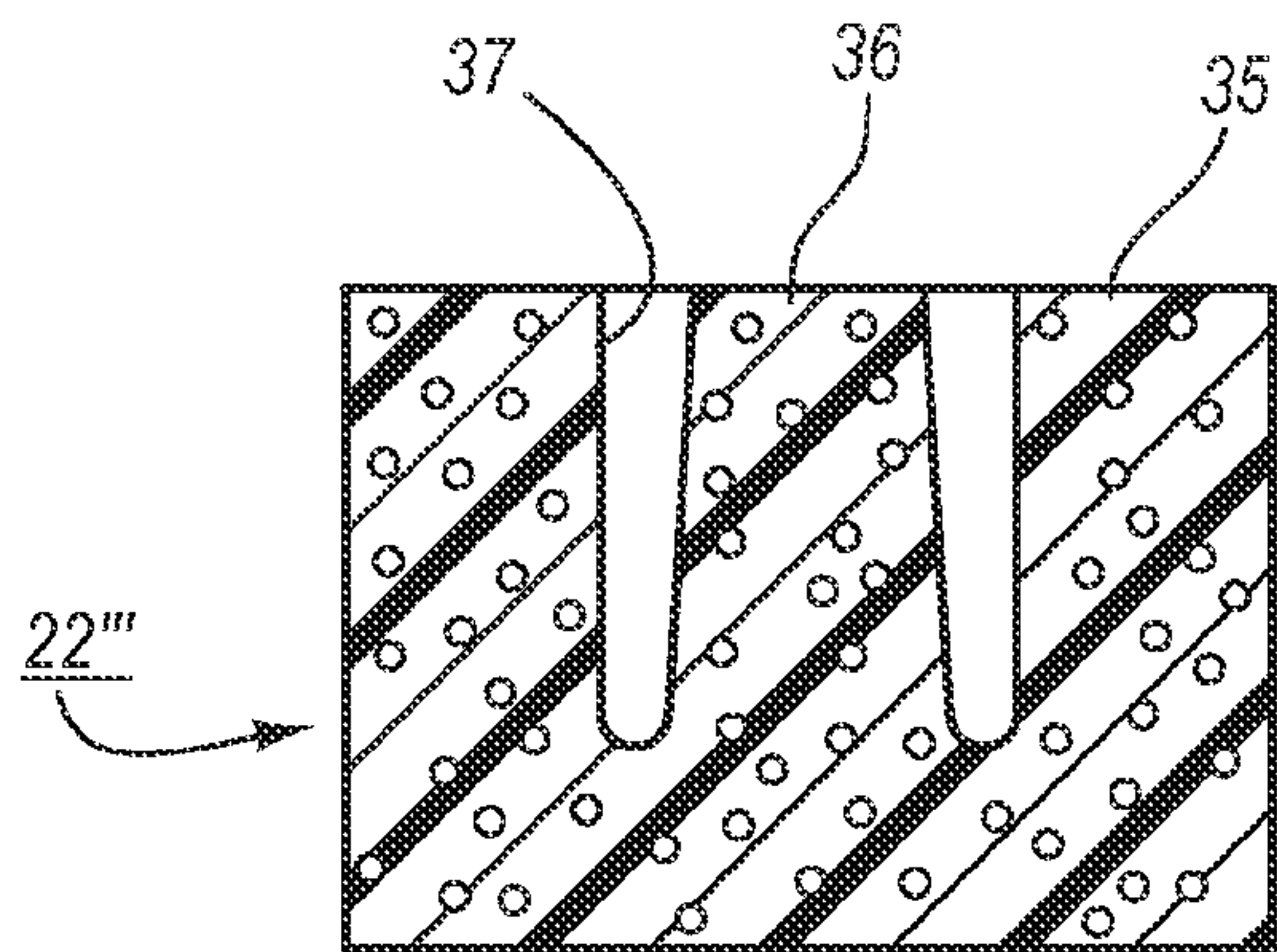

Fig. 11

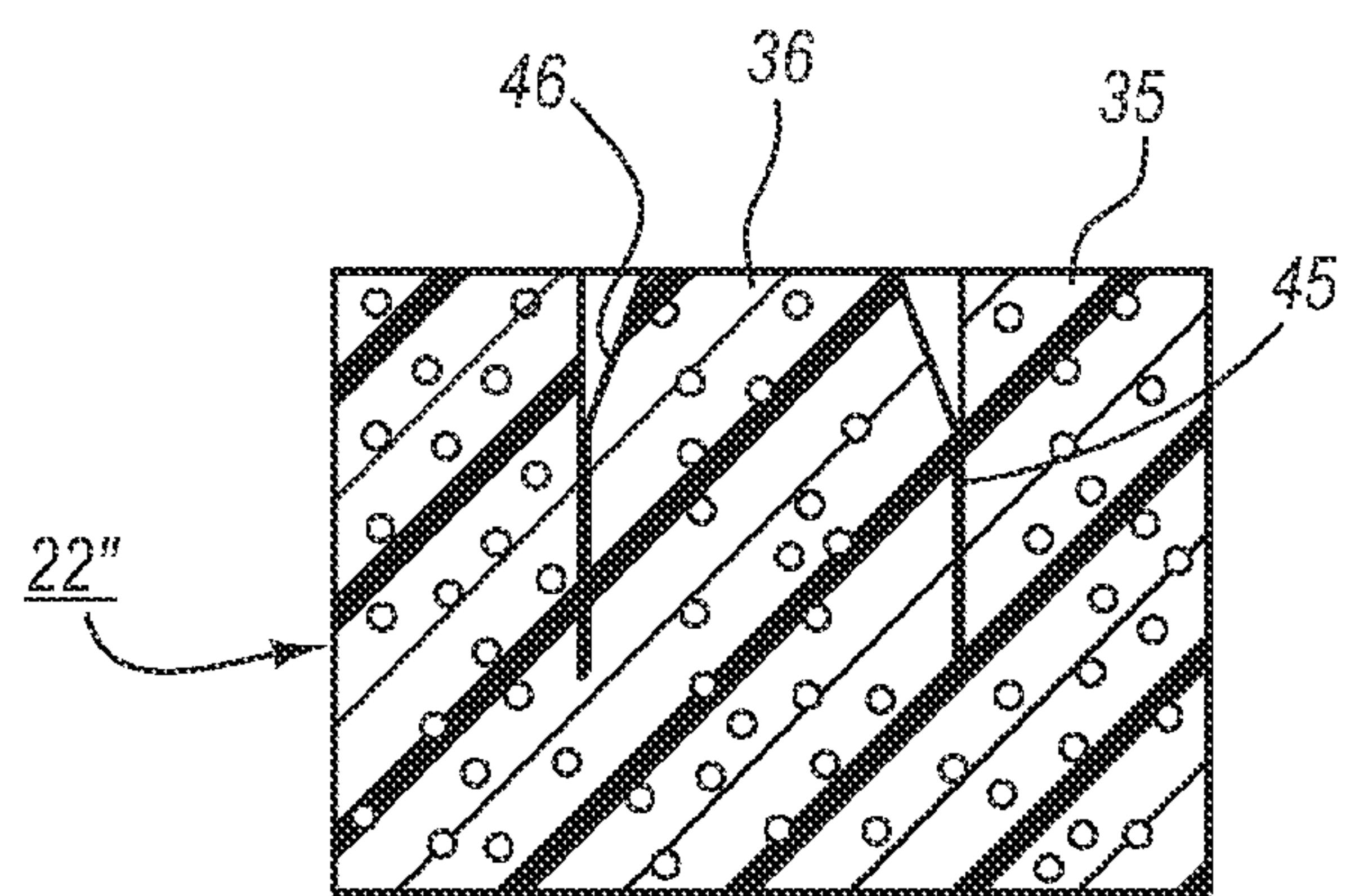

Fig. 10

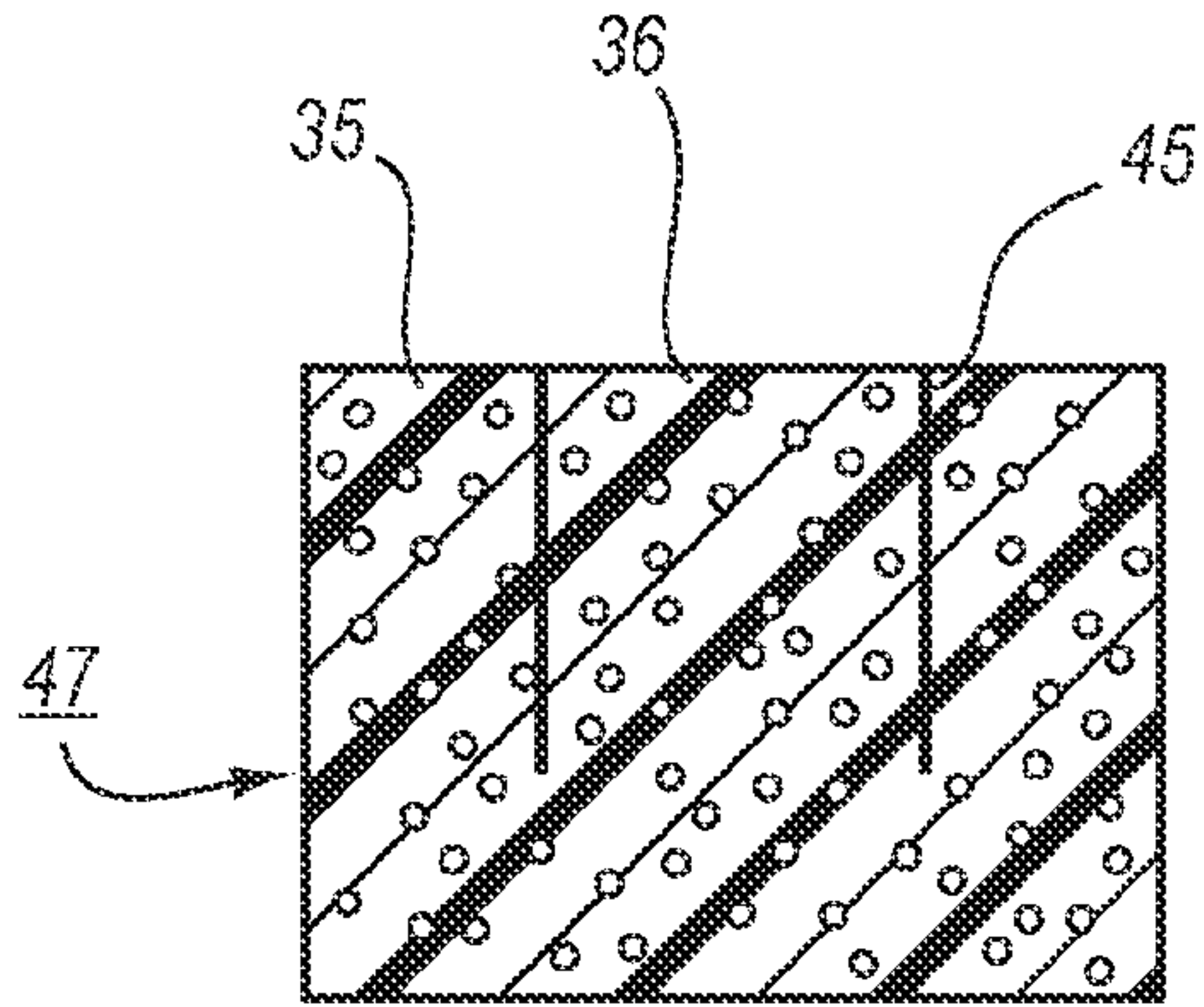

Fig. 12

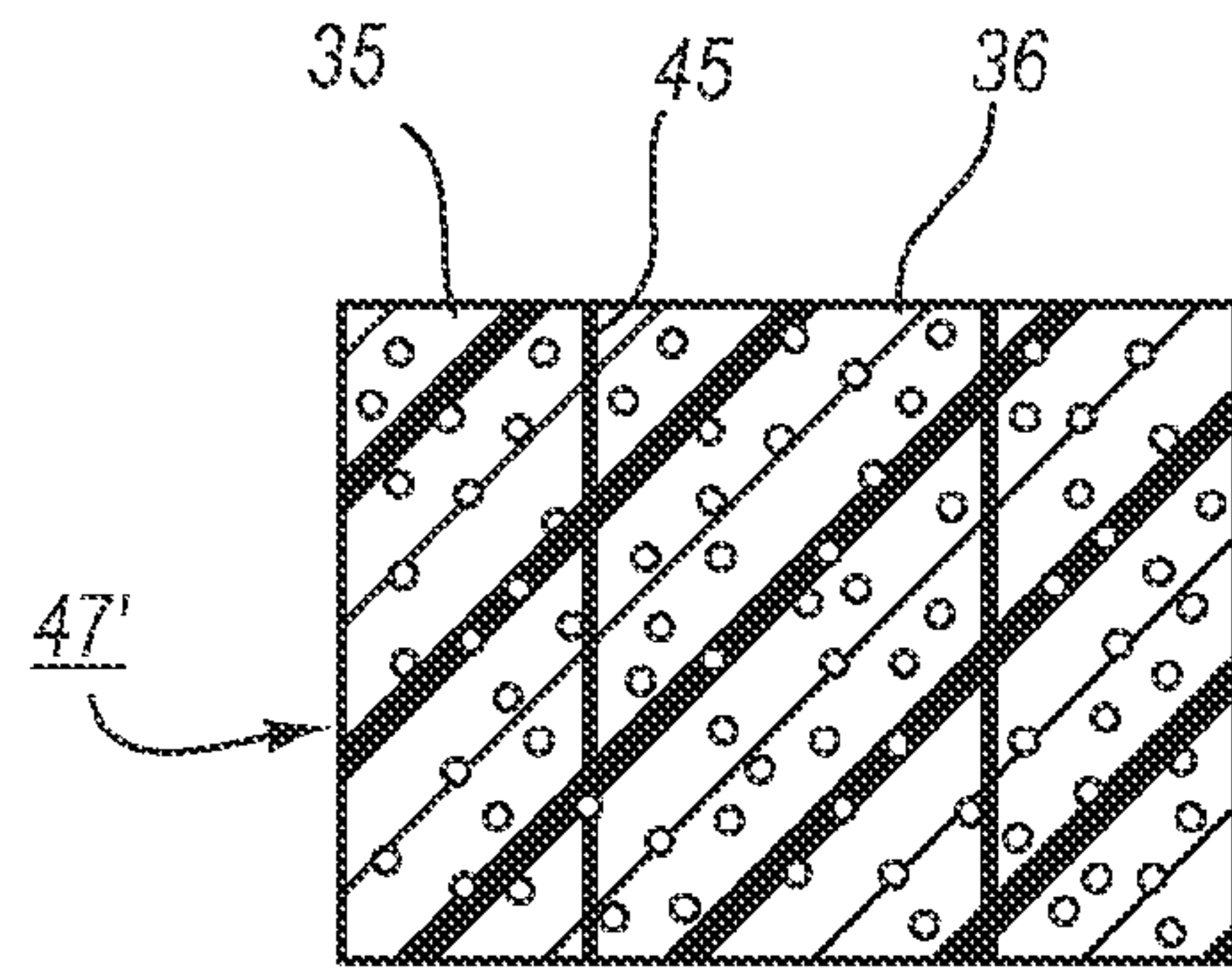

Fig. 13

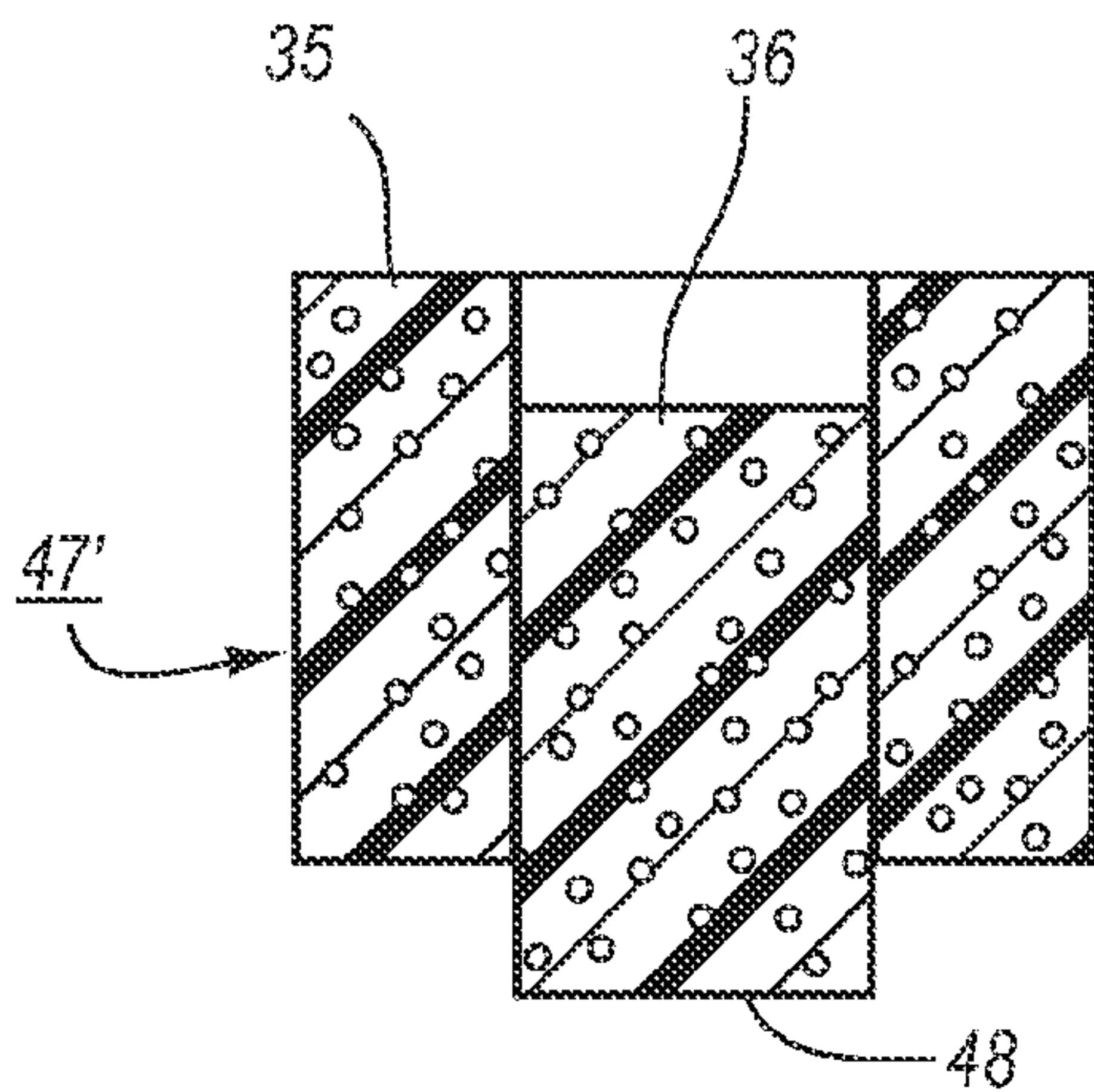

Fig. 14

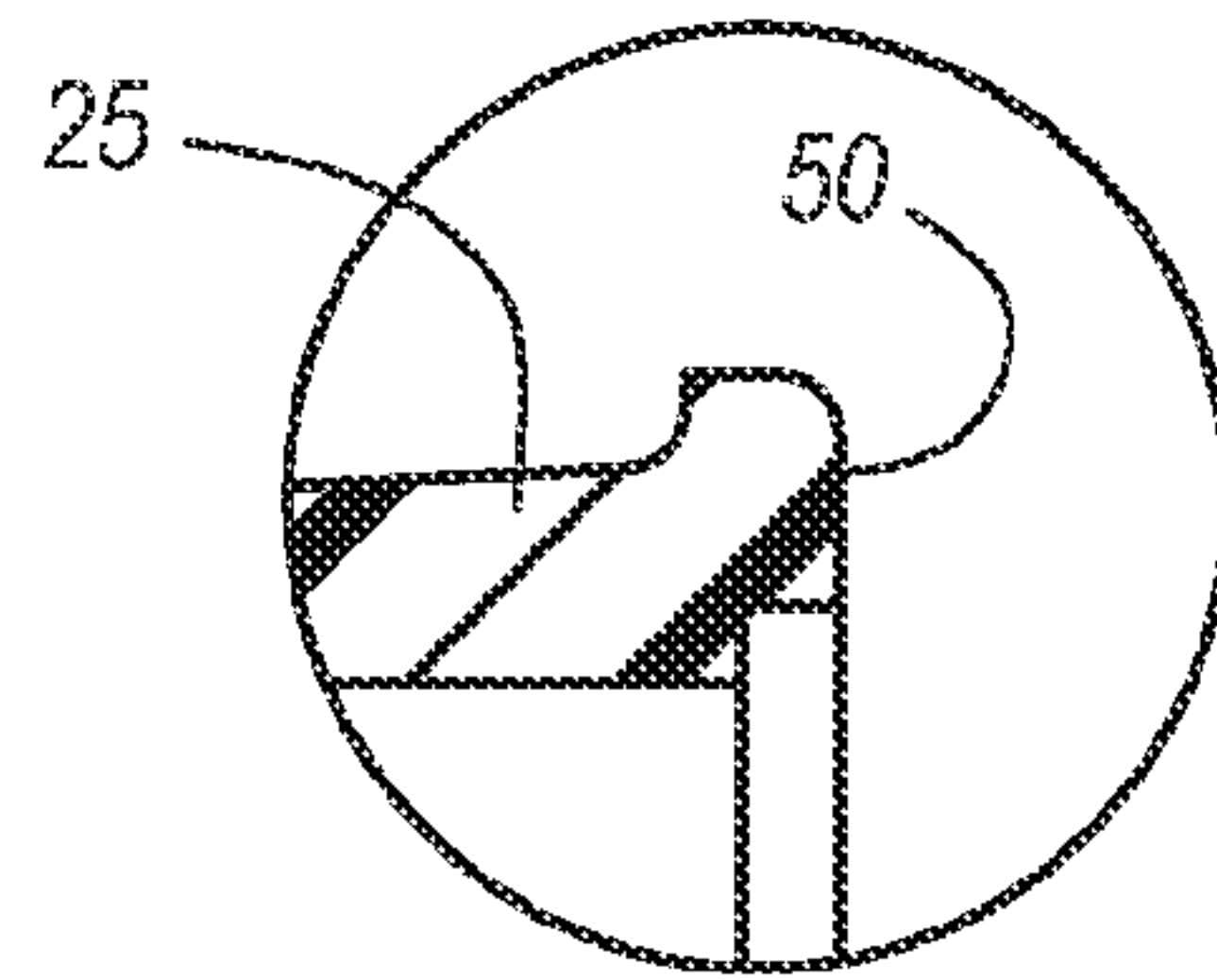

Fig. 15

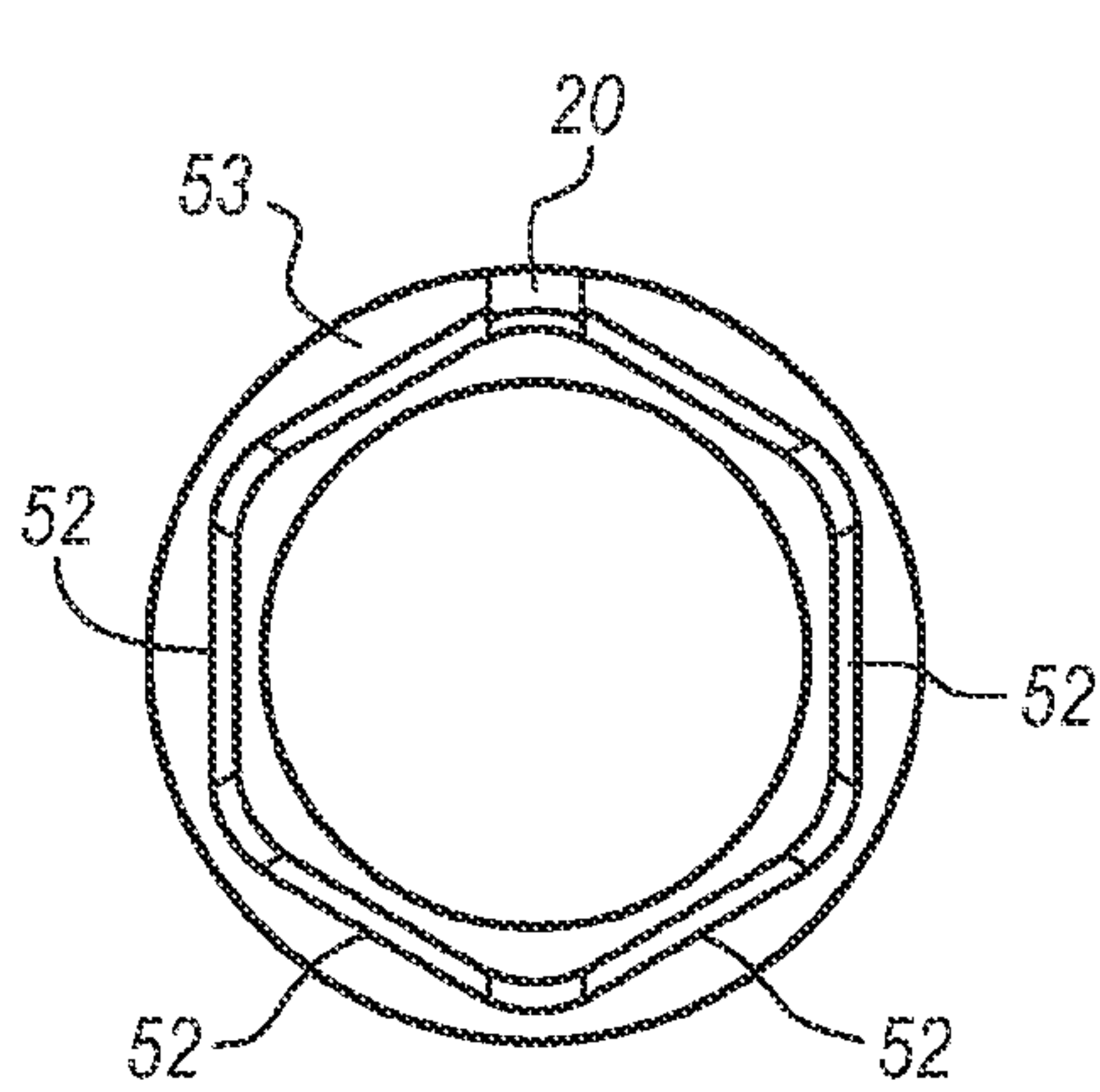

Fig. 17

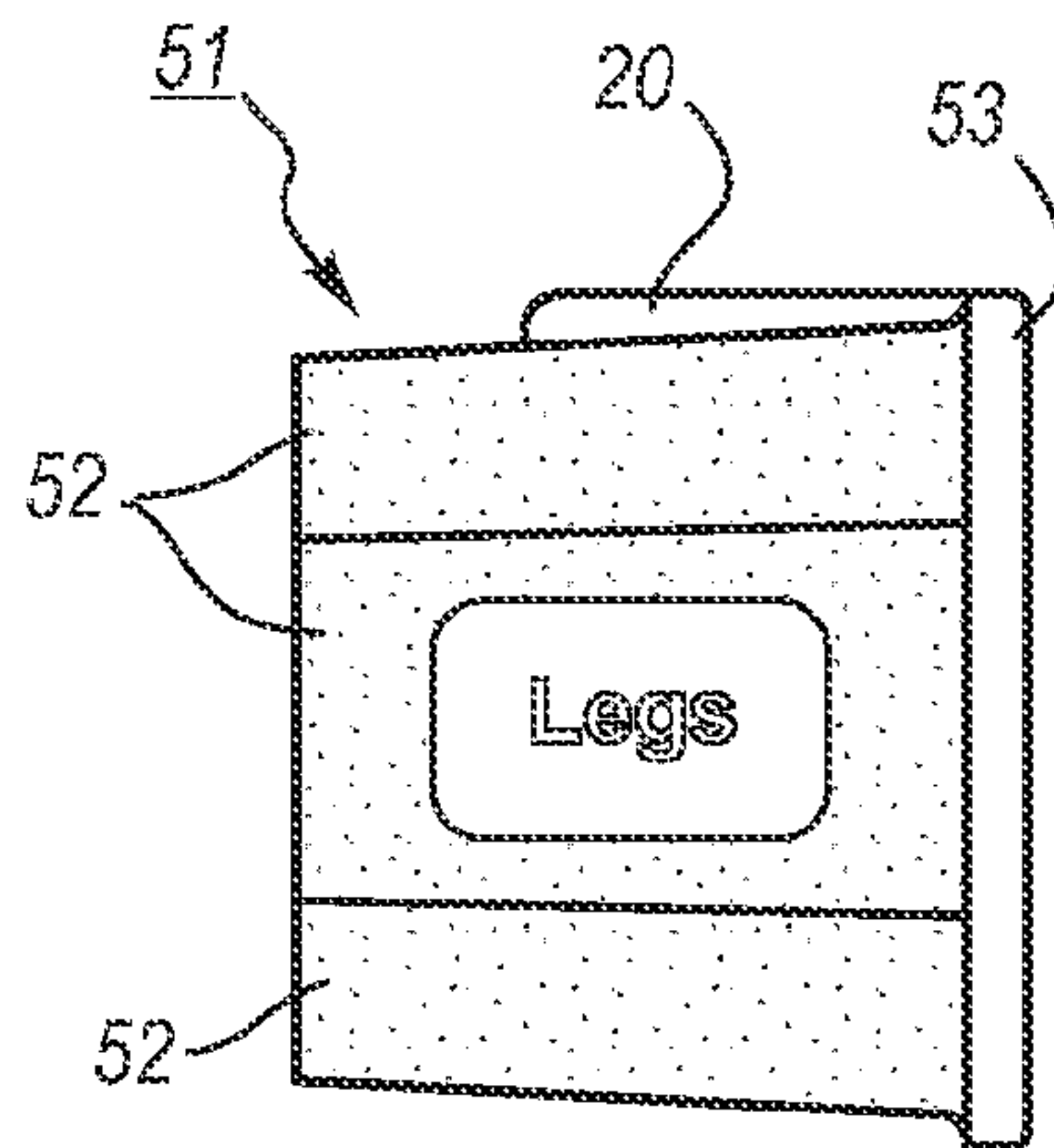

Fig. 16

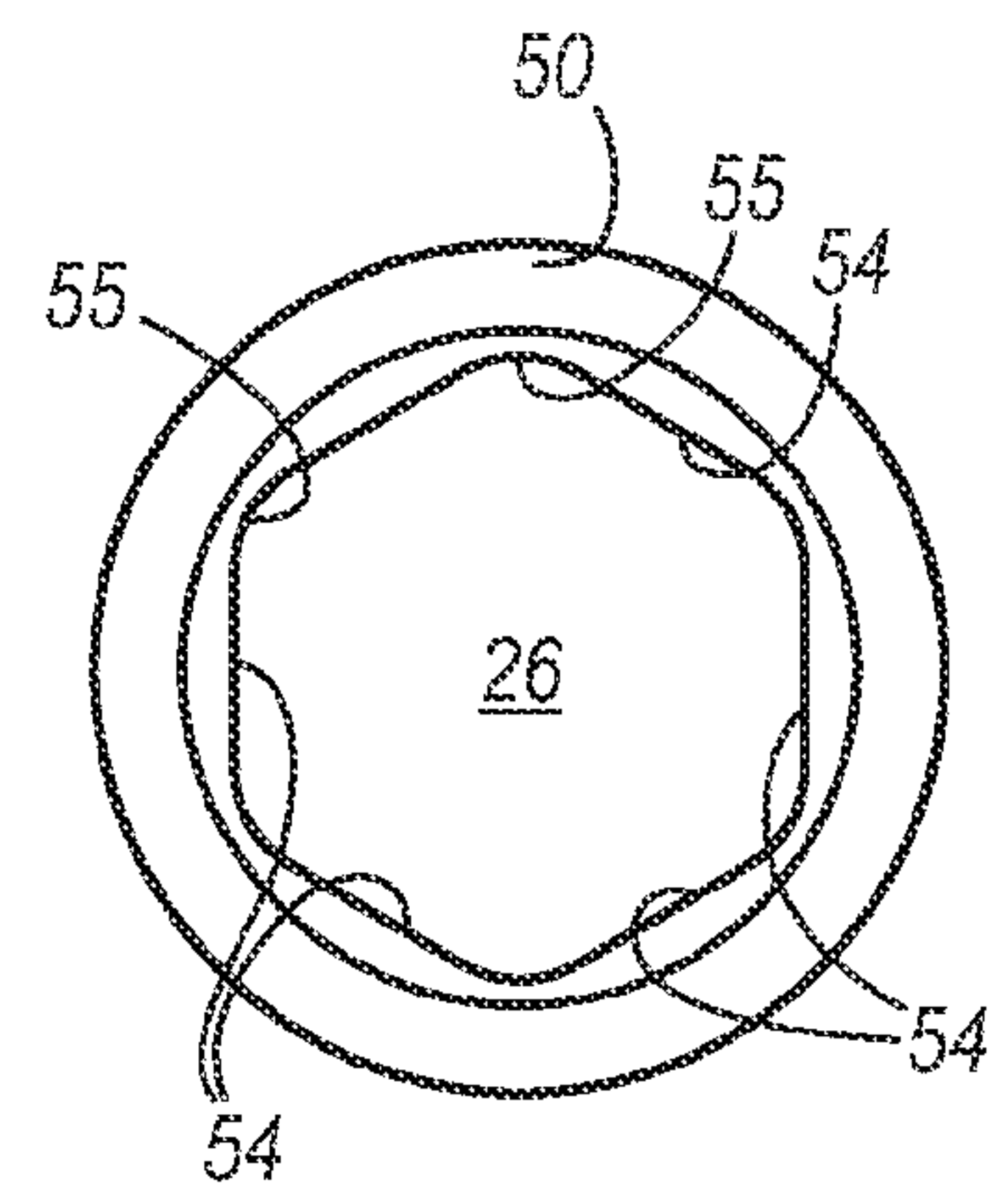

Fig. 18

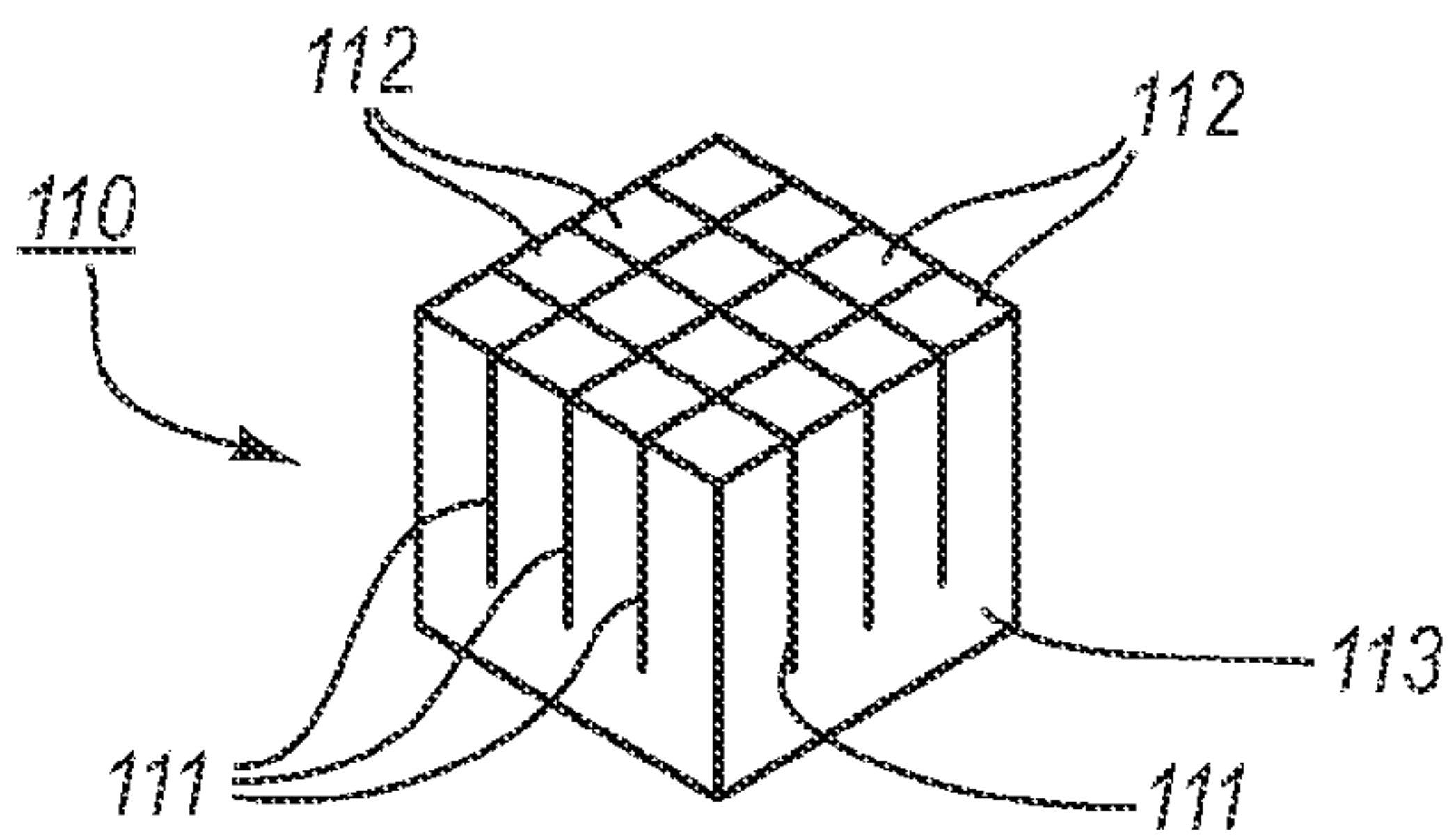

Fig. 19

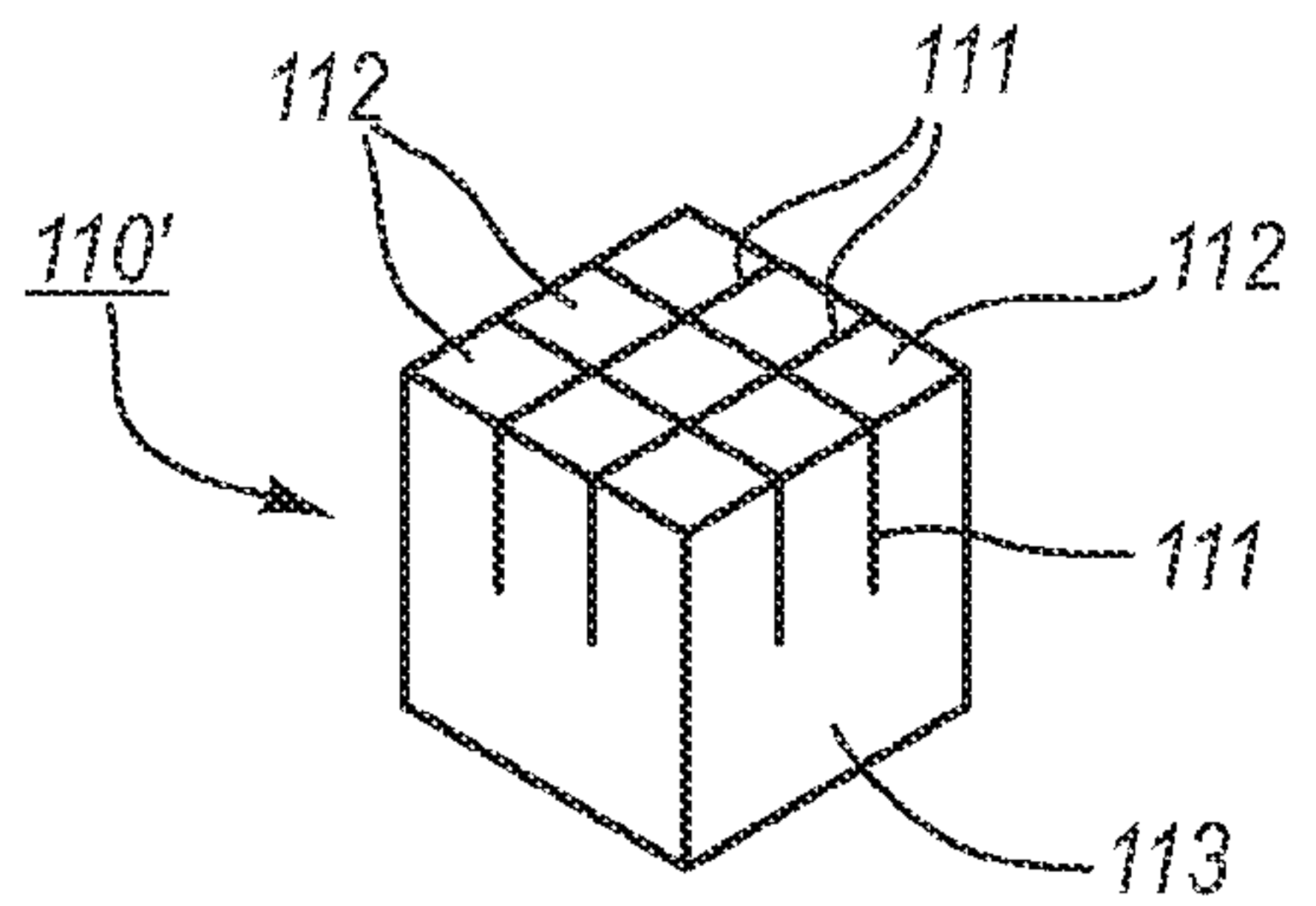

Fig. 20A

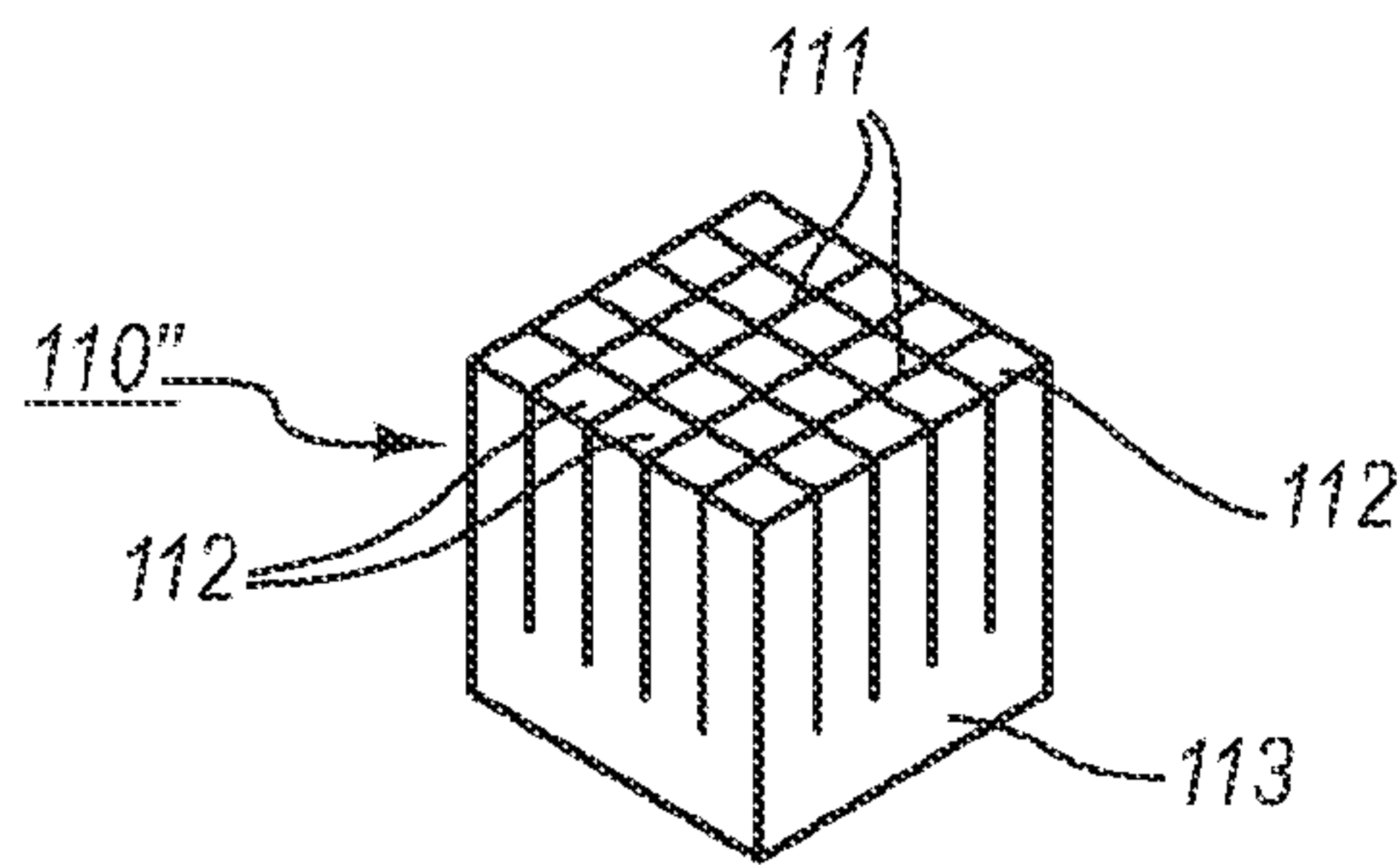

Fig. 20B

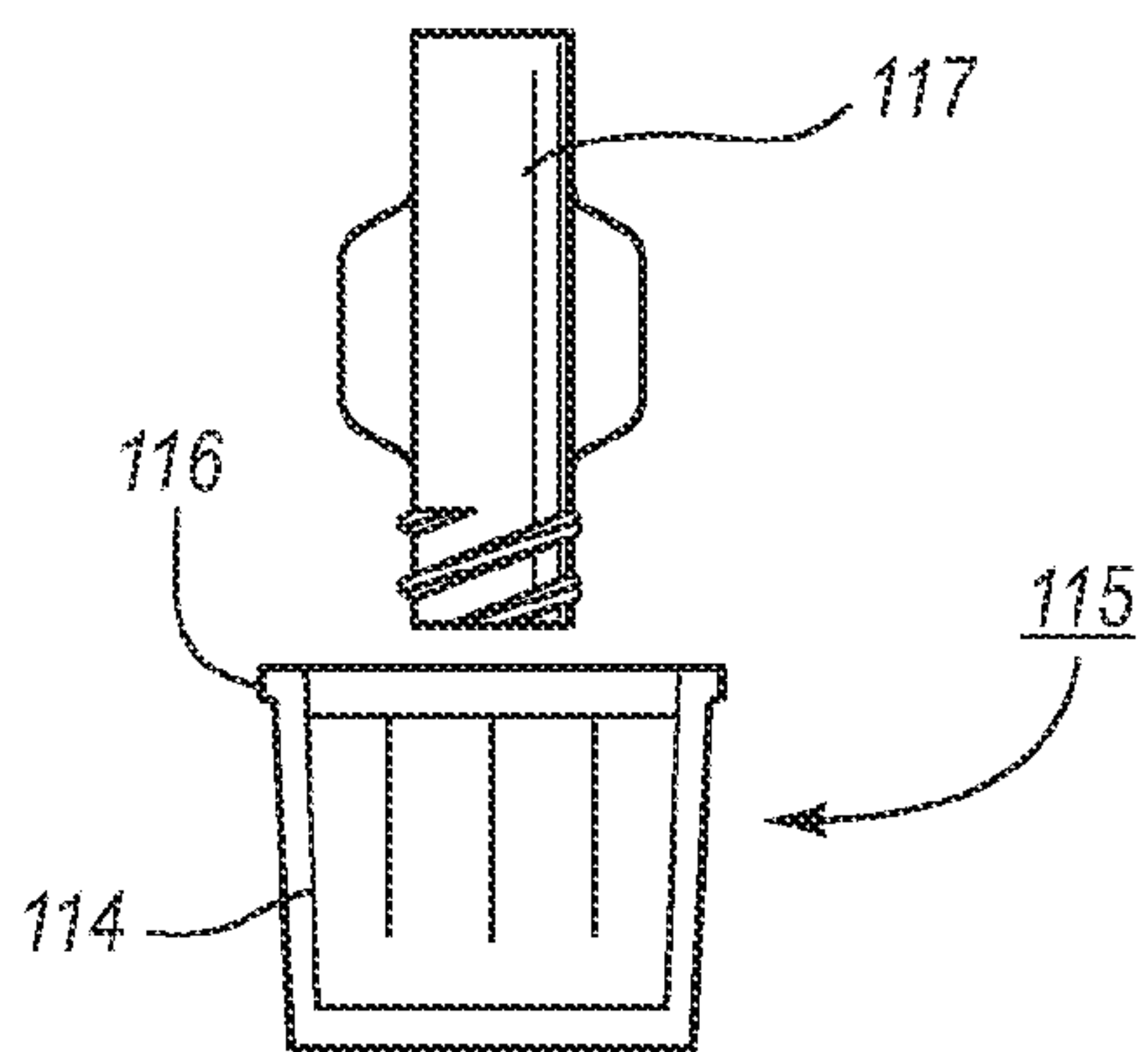

Fig. 22

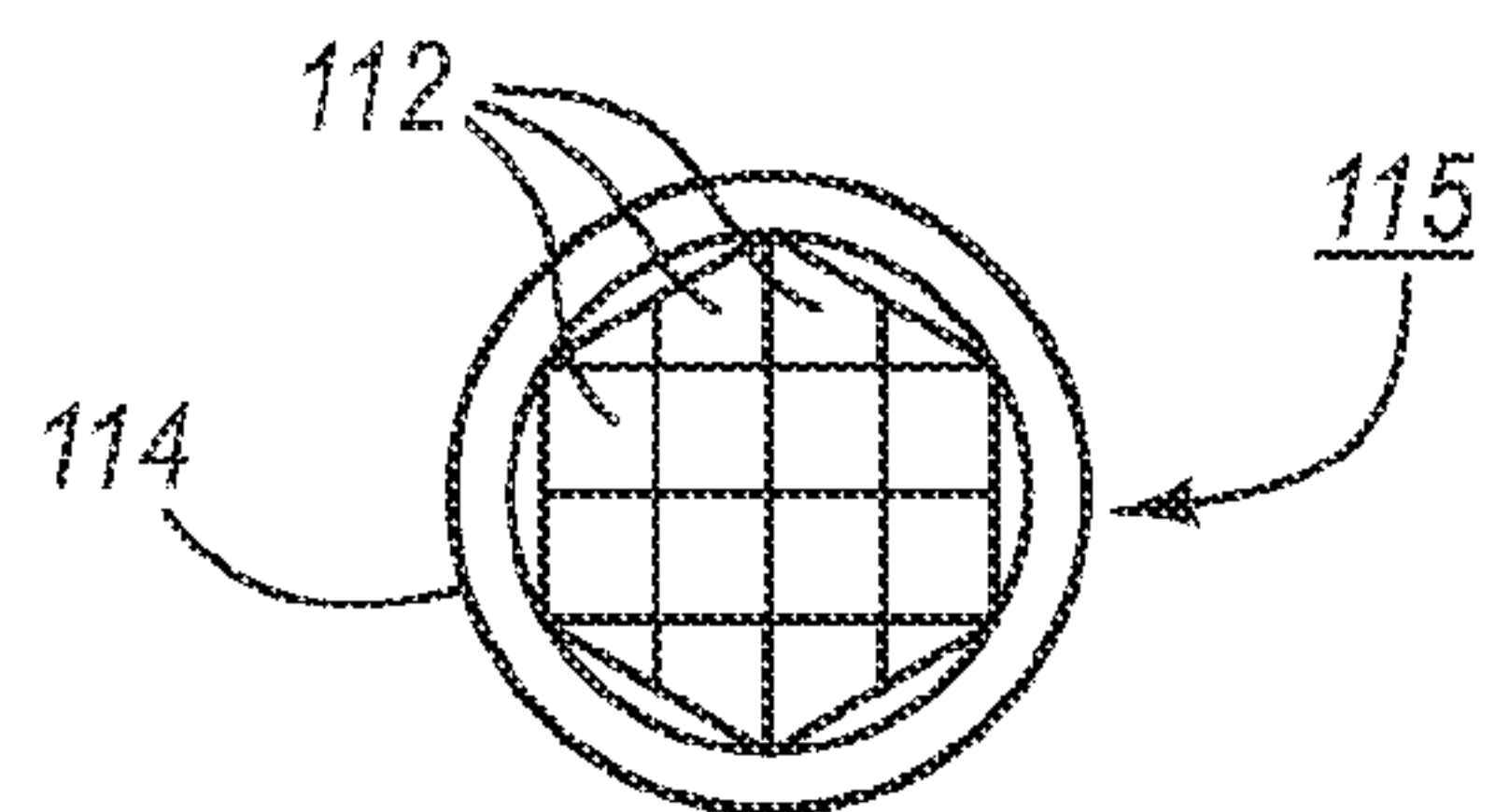

Fig. 21

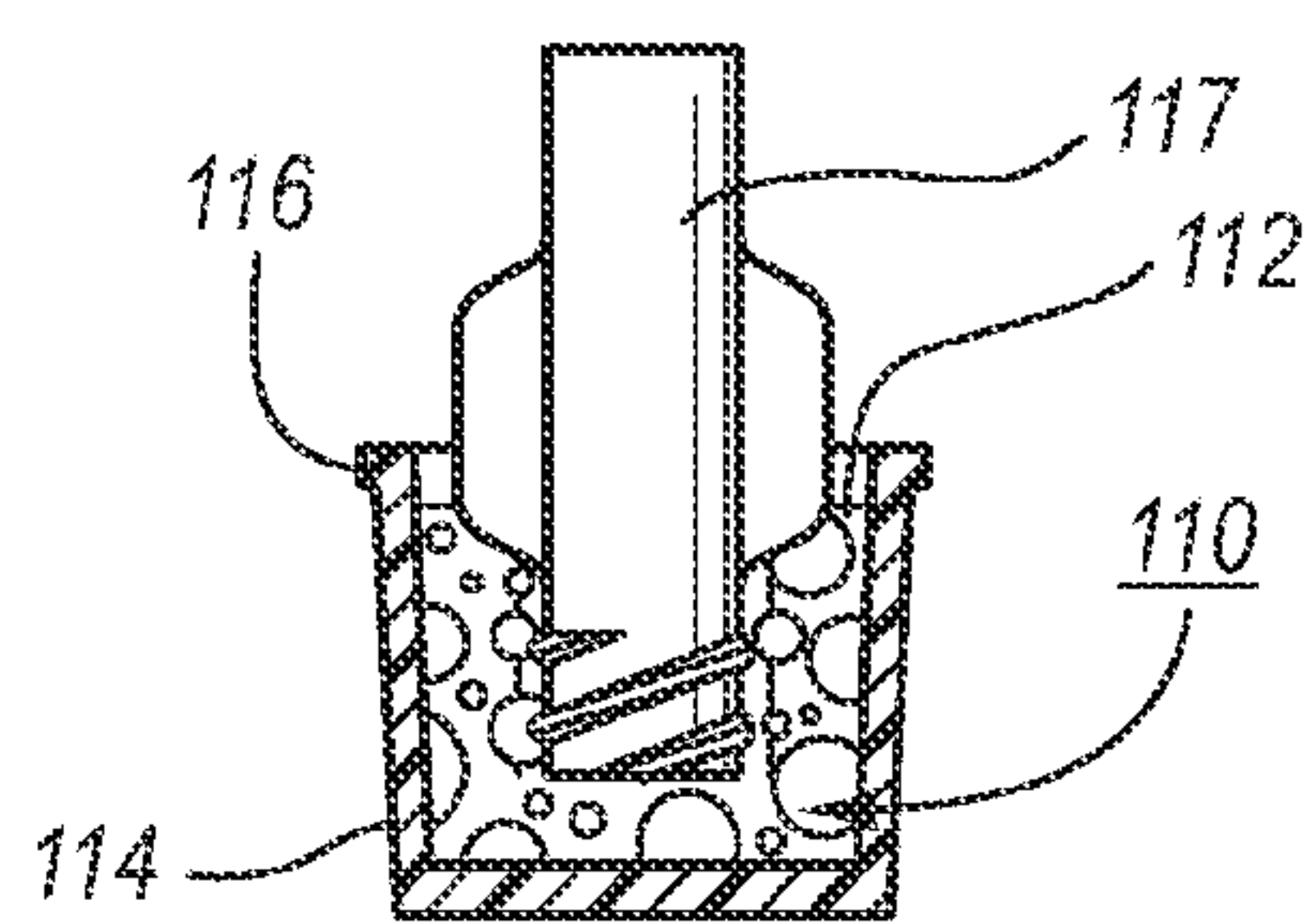

Fig. 23

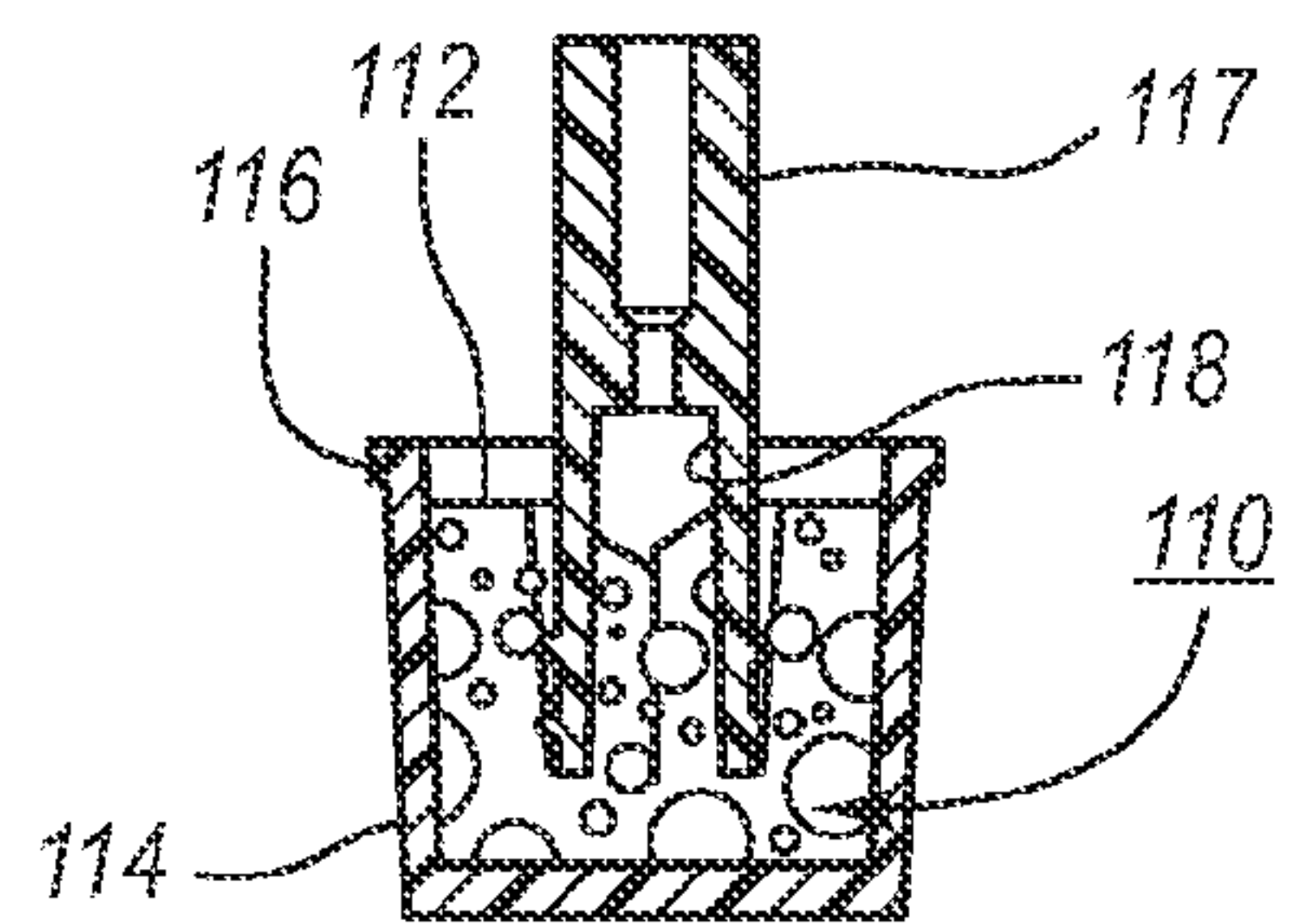

Fig. 24

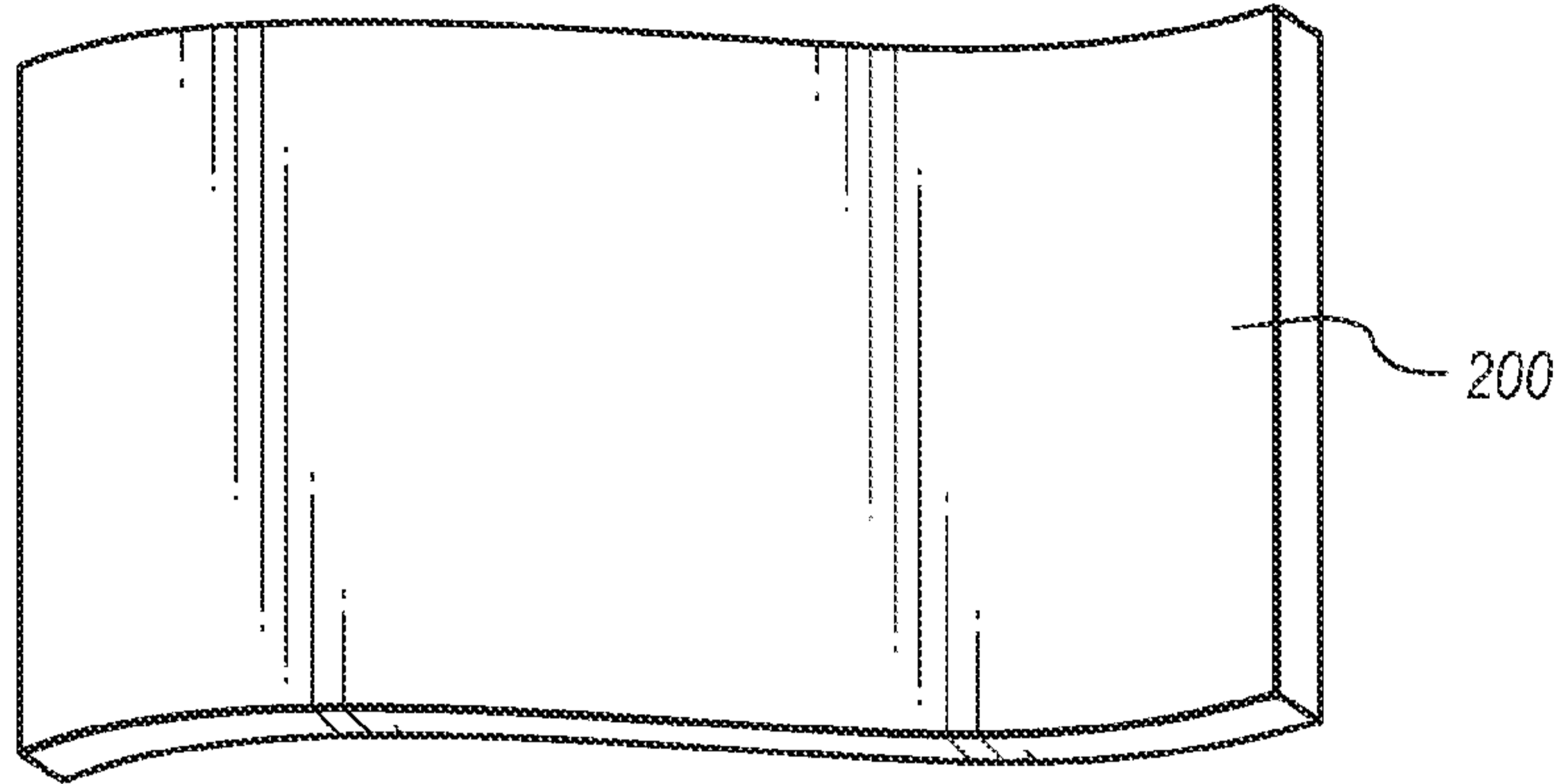

Fig. 25

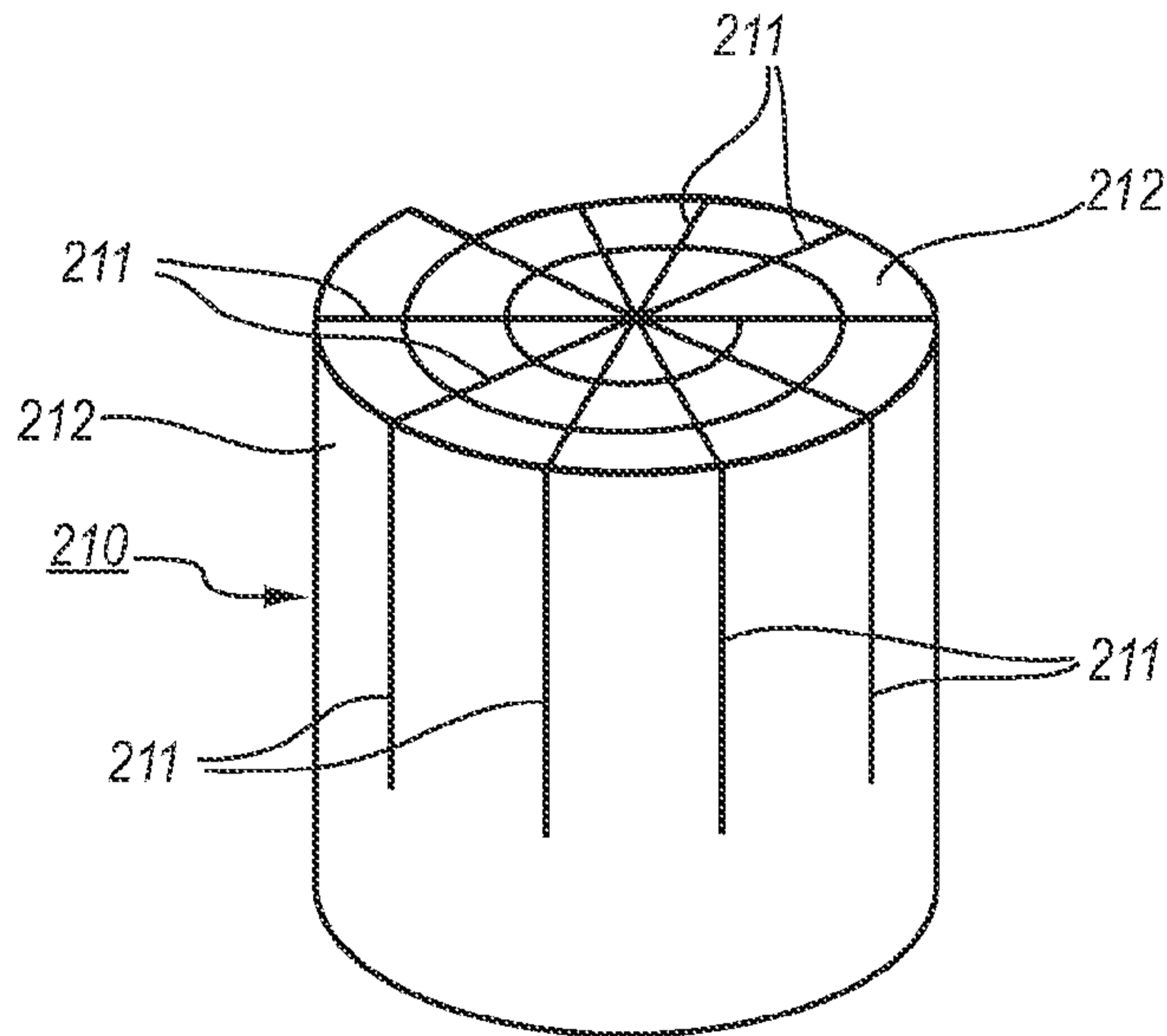

Fig. 26

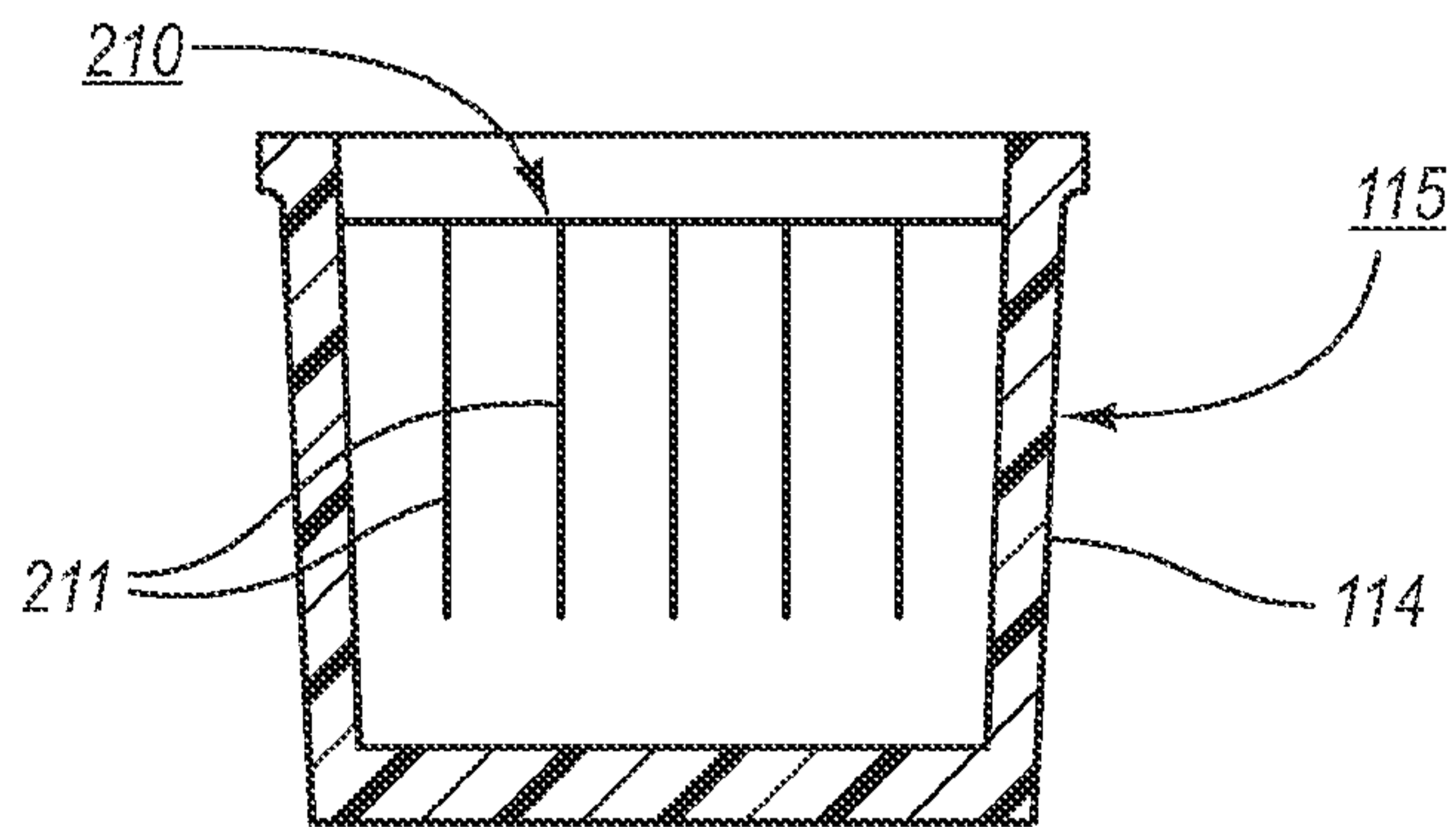

Fig. 27

