



(11) **EP 3 486 567 B1**

(12) **EUROPEAN PATENT SPECIFICATION**

(45) Date of publication and mention of the grant of the patent:  
**26.01.2022 Bulletin 2022/04**

(21) Application number: **18206586.2**

(22) Date of filing: **15.11.2018**

(51) International Patent Classification (IPC):  
**F23R 3/00<sup>(2006.01)</sup>**

(52) Cooperative Patent Classification (CPC):  
**F23R 3/002; F23R 2900/00014; F23R 2900/03045; F23R 2900/03341; F23R 2900/03342**

(54) **CAN COMBUSTOR FOR A GAS TURBINE AND GAS TURBINE COMPRISING SUCH A CAN COMBUSTOR**

ROHRBRENNER FÜR EINE GASTURBINE UND GASTURBINE MIT SOLCH EINEM ROHRBRENNER

CHAMBRE DE COMBUSTION TUBULAIRE POUR UNE TURBINE À GAZ ET TURBINE À GAZ COMPORTANT UNE TELLE CHAMBRE DE COMBUSTION TUBULAIRE

(84) Designated Contracting States:  
**AL AT BE BG CH CY CZ DE DK EE ES FI FR GB GR HR HU IE IS IT LI LT LU LV MC MK MT NL NO PL PT RO RS SE SI SK SM TR**

(30) Priority: **15.11.2017 EP 17201899**

(43) Date of publication of application:  
**22.05.2019 Bulletin 2019/21**

(73) Proprietor: **Ansaldo Energia Switzerland AG**  
**5401 Baden (CH)**

(72) Inventor: **BOTHIEN, Mirko Ruben**  
**8037 ZÜRICH (CH)**

(74) Representative: **Martini, Gabriele et al**  
**Studio Torta S.p.A.**  
**Via Viotti, 9**  
**10121 Torino (IT)**

(56) References cited:  
**EP-A1- 1 669 670 EP-A1- 3 029 377**  
**EP-A2- 0 896 193 US-A1- 2016 003 162**  
**US-A1- 2016 215 984**

**EP 3 486 567 B1**

Note: Within nine months of the publication of the mention of the grant of the European patent in the European Patent Bulletin, any person may give notice to the European Patent Office of opposition to that patent, in accordance with the Implementing Regulations. Notice of opposition shall not be deemed to have been filed until the opposition fee has been paid. (Art. 99(1) European Patent Convention).

## Description

### CROSS-REFERENCE TO RELATED APPLICATIONS

**[0001]** This application claims priority from European Patent Application No. 17201899.6 filed on November 15, 2017.

### Field of the Invention

**[0002]** The present invention relates to a can combustor for a gas turbine for power plants. In particular, the present invention relates to a can combustor provided with a damper. Moreover, the present invention refers to a gas turbine for power plants comprising the above mentioned can combustor.

### Description of prior art

**[0003]** As known, a gas turbine for power plants (in the following only gas turbine) comprises a rotor provided with an upstream compressor sector, a combustor sector and a downstream turbine sector. The terms downstream and upstream refer to the direction of the main gas flow passing through the gas turbine. In particular, the compressor comprises an inlet supplied with air and a plurality of blades compressing the passing air. The compressed air leaving the compressor flows into a plenum, i.e. a closed volume delimited by an outer casing, and from there into the combustor. Inside the combustor the compressed air is mixed with at least one fuel. The mixture of fuel and compressed air flows into a combustion chamber inside the combustor where this mixture are combusted. The resulting hot gas leaves the combustor and is expanded in the turbine performing work on the rotor.

**[0004]** In order to achieve a high efficiency, a high turbine inlet temperature is required. However, due to this high temperature, high NO<sub>x</sub> emissions are generated.

**[0005]** In order to reduce these emissions and to increase operational flexibility, today is known a particular kind of gas turbines performing a sequential combustion cycle.

**[0006]** In general, a sequential gas turbine comprises two combustors in series wherein each combustor is provided with the relative burner and combustion chamber. Following the main gas flow direction, the upstream combustor is called "premix" combustor and is fed by the compressed air. The downstream combustor is called "sequential" or "reheat" combustor and is fed by the hot gas leaving the first combustion chamber. According to a first kind of sequential gas turbines, the two combustors are physically separated by a stage of turbine blades, called high pressure turbine.

**[0007]** Following the main gas flow, this first kind of sequential gas turbines comprises a compressor, a first combustor, a high-pressure turbine, a second combustor and a low-pressure turbine. The compressor and the two turbines may be connected to a common rotor rotating

around an axis and surrounded by a concentric casing.

**[0008]** Today a second kind of sequential gas turbines is known wherein this kind of gas turbines is not provided with the high pressure turbine and the premix and the reheat burner are arranged directly one downstream the other inside a common can-shaped casing. According to this kind of sequential gas turbines, a plurality of can combustors are provided arranged as a ring around the turbine axis. Each can-combustor is provided with a liner, i.e. the casing limiting the inner combustion chambers, divided in two portions respectively upstream and downstream with respect to the reheat burner. The upstream portion of the liner is called premix liner whereas the downstream portion is called sequential liner and is downstream connected with a flange, called picture frame, facing the turbine. Usually, the sequential liner and the picture frame are realized as a single piece called transition duct configured for guiding the hot gas leaving the combustor toward the turbine, in particular toward the first vane of the turbine. For instance, the reheat burner can be realized in form of a plurality of single or dual fuel injector fingers extending across the flow channel. Preferably, these injector fingers can be realized in form of a streamline body having preferably a lobed trailing edge.

**[0009]** Of course, according to the prior art practice it is possible to realize a can combustor with a single combustion stage and accordingly comprising a single burner and a single liner defining a single combustion chamber.

**[0010]** The above described different kinds of gas turbines, i.e. the can combustor with a single or two combustion stages, have been cited because the present invention can be applied in all these two different kinds of can combustors.

**[0011]** During operation, inside the combustion chambers pressure oscillations may be generated that could cause mechanical damages and limit the operating regime. Mostly gas turbines have to operate in lean mode for compliance to pollution emissions. The burner flame during this mode of operation is extremely sensitive to flow perturbations and can easily couple with dynamics of the combustion chamber to lead to thermo-acoustic instabilities. For this reason, usually combustion chambers are provided with damping devices, in order to damp these pressure oscillations.

**[0012]** A traditional damper comprises a damper volume that acts as a resonator volume and a neck fluidly connecting the damper volume to the combustion chamber.

**[0013]** In order to reduce the installation size of the damper, today is known to arrange damper volume around the combustion chamber. This kind of installation is suitable for can combustors and in view of the disposition around the can combustor, this kind of dampers are called "annular" dampers.

**[0014]** US8490744 discloses an annular damper as above described. In particular, US8490744 discloses a can combustor for a gas turbine having a single stage of

combustion wherein the can combustor comprises a burner, a liner arranged downstream the burner and defining an inner combustion chamber and a damper comprising a damper volume wrapped outside the liner and in fluidly connections with the combustion chamber. According to US8490744, in order to minimize the installation size of the damper, the inner wall of the damper volume corresponds to the liner and the damper necks collapse in a plurality of through holes provided in the liner.

**[0015]** Starting from this prior art, there is today the need to improve the foregoing described configuration of dampers wrapped around the liner.

**[0016]** US2016215984 discloses a combustor assembly comprising a liner and a damper assembly provided with a damper volume and a damper neck acting as a bridge between the damper volume and the combustor. According to US2016215984 the damper neck may be alternatively integral with the combustor. This document discloses the or with the damper volume. preamble of independent claim 1.

#### SUMMARY OF THE INVENTION

**[0017]** A primary object of the present invention is to provide a can combustor provided with a new damper wrapped around the liner.

**[0018]** In order to achieve the objective mentioned above, the present invention provides a can combustor for a gas turbine according to claim 1.

**[0019]** In particular, the above mentioned damper can be considered as a resonator device or acoustic damper.

**[0020]** According to the above general description of the invention, the can combustor may be provided with a single stage of combustion or two stages of combustion arranged in series. In the first case (single combustion stage) the can combustor comprises a burner followed downstream by a liner defining the combustion chamber and guiding the hot gas flow toward the turbine. The term downstream refers to the hot gas main flow direction. The cross-section of the liner defining the combustion chamber may be circular or square/rectangular.

**[0021]** According to the invention, the damper body is annular and arranged spaced from the liner, i.e. the damper body has an inner surface facing the outer surface of the liner, in order to create a cooling gap or channel between the damper body and the liner. In this cooling gap between the liner and the damper body at least a damper neck is present acting as a bridge for fluidly connecting the damping volume with the combustion chamber. Moreover, in order to increase the cooling effect of the cooling air passing through the cooling channel, according to the invention, the cooling gap between the damper body and the liner is provided with a cooling device, for instance a plurality of trip strips or turbolator elements or other different kinds of cooling device. This cooling device is placed on the outer surface of the liner and on the inner wall of the damper body. The ends of the damper neck may be in flush with the liner and/or the

damper body or alternatively may protrude at least in part inside the combustion chamber and/or in the damping volume. The term "inner" refers to the combustor axis.

**[0022]** Advantageously, according to the above technical features it is possible to create a controlled convective cooling air flow (in the following will be described that this cooling air is the compressed air delivered in the plenum by the compressor) between the damper body and the liner and therefore the purge air passing through the damper body may be independently adjusted without impacting the liner cooling. In this way, a damper purge air reduction, for instance applied for optimizing the damping effect, does not involve any detrimental effect on the liner cooling.

**[0023]** According to alternative embodiments, the damper body may wrap the liner completely or only in part. Preferably, the damper body wraps the liner completely and the damping volume can be divided in a plurality of sub-volumes.

**[0024]** Of course, the damper may comprises a plurality of damper necks connecting the combustion chamber with the damping volume.

**[0025]** As foregoing mentioned, the damper comprises at least a purge air inlet configured for entering purge air in the damping volume. According to alternative embodiments, the purge air inlet may be located on the outer wall of the damper body or on the inner wall of the damper body facing the liner. Preferably, in this last embodiment the purge air inlet may be located between the damper neck and the damper body. In this case, part of the cooling air passing through the cooling gap enters into the damping volume acting as purge air. According to the present invention it also possible to provide the damper with two purge air inlets wherein a first purge air inlet is located between the damper neck and the damper body and the second purge air inlet is located on the outer wall of the damper body.

**[0026]** Preferably, the can combustor is a sequential can combustor and comprises in series a first burner, a first liner defining a first combustion chamber, a subsequent burner and a subsequent liner defining a subsequent combustion chamber. In this configuration the damper is associated at least to the subsequent liner.

**[0027]** The invention has been foregoing described as referring to the can combustor. However, the present invention refers also to a gas turbine for power plants comprising such a can combustor wherein preferably this can combustor is a sequential can combustor.

**[0028]** It is to be understood that both the foregoing general description and the following detailed description are exemplary, and are intended to provide further explanation of the invention as claimed. Other advantages and features of the invention will be apparent from the following description, drawings and claims.

**[0029]** The features of the invention believed to be novel are set forth with particularity in the appended claims.

## BRIEF DESCRIPTION OF DRAWINGS

**[0030]** Further benefits and advantages of the present invention will become apparent after a careful reading of the detailed description with appropriate reference to the accompanying drawings.

**[0031]** The invention itself, however, may be best understood by reference to the following detailed description of the invention, which describes an exemplary embodiment of the invention, taken in conjunction with the accompanying drawings, in which:

- figure 1 is a schematic view of a gas turbine for power plants provided with a can combustor having a single combustion stage;
- figure 2 is a schematic view of a can combustor for a gas turbine for power plants provided in series with a premix and a reheater burner;
- figure 3 is a schematic view of a first embodiment of the present invention;
- figure 4 is an enlarged view of a portion of figure 3;
- figure 5 is a schematic view of a second embodiment of the present invention; and
- figure 6 is a schematic view of enlarged view of a portion of figure 5;
- figure 7 is a schematic view of a third embodiment of the present invention that could be considered as a hybrid of the foregoing embodiments of figures 4 and 6. The cooling device according to claim 1 is not shown in the drawings.

## DETAILED DESCRIPTION OF DRAWINGS

**[0032]** In cooperation with the attached drawings, the technical contents and detailed description of the present invention are described hereinafter according to preferable embodiments, being not used to limit its executing scope. Any equivalent variation and modification made according to appended claims is all covered by the claims claimed by the present invention.

**[0033]** Reference will now be made to the enclosed drawings to describe the present invention in detail.

**[0034]** Reference is now made to Fig. 1 that is a schematic view of a gas turbine for power plants that can be provided with a can combustor according to the present invention. In particular, figure 1 discloses a gas turbine 1 having an axis 9 and comprising a compressor 2, a combustor sector 4 and a turbine 3. As known, ambient air 10 enters the compressor 2 and compressed air leaves the compressor 2 and enters in a plenum 16, i.e. a volume defined by an outer casing 17. From the plenum 16, the compressed air 37 enters in the combustor that comprises a plurality of can combustors 4 annularly arranged as ring around the axis 9. In the description of figure 1, the terms annular, radial, axial, inner and outer refer to the axis 9 whereas the terms downstream and upstream refer to the gas main flow. Each can combustor 4 involves a single stage of combustion and comprises

a burner 5 where the compressed air 37 is mixed with at least a fuel. This mixture is then combusted in a combustion chamber 6 and the resulting hot gas flows toward a downstream turbine 3. The combustion chamber 6 is limited by a liner 7. The turbine 3 comprises a plurality of vanes 12, i.e. stator blades, supported by a vane carrier 14, and a plurality of blades 13, i.e. rotor blades, supported by a rotor 8. In the turbine 3, the hot gas expands performing work on the rotor 8 and leaves the turbine 3 in form of exhaust gas 11.

**[0035]** Reference is now made to figure 2 that is schematic view of a different kind of can combustor that can be improved according to the present invention. In particular, figure 2 disclose a can combustor 4 having two stages of combustion in series and housed in a relative portal hole of an outer casing 17 defining the plenum 16 where the compresses air are delivered by the compressor 2. The can combustor 4 has an axis 24 and comprises in series along the gas flow M a first combustor, or premix combustor 18, and a second combustor, or sequential combustor 19. In particular, the first combustor 18 comprises a first or premix burner 20 and a first combustion chamber 21. The sequential combustor 19 comprises a sequential burner 22 and a second combustion chamber 23. The burner axis 24 is parallel to the gas flow direction M and the sequential burner 22 may comprise a plurality of fuel injectors, in particular dual fuel and carrying air injectors. According to the embodiment of figure 2, the fuel is fed to the sequential burner 22 by a fuel lance 25 axially extending outside the first combustion chamber 21 up to the sequential burner 22. The combustion chambers 21 23 are delimited by a liner 7. In particular, the premix combustion chamber 21 is limited by an upstream portion of the liner 7 and the sequential combustion chambers 21 by a sequential liner 26 that is part of a transition duct 27 for guiding the hot gas toward the turbine.

**[0036]** Reference is now made to figures 3-7 that are schematic views of two alternative embodiments of the present invention. In these figures, the reference number 7 refers to a liner in general and therefore may correspond to the single liner 7 of the can combustor 4 of figure 1 but also to the sequential liner 26 of figure 2. In the same way, in the figures 3-7 the reference number 6 refers to a combustion chamber in general and therefore may correspond to the combustion chamber 6 of the can combustor 4 of figure 1 but also to the sequential combustion chamber 23 of figure 2. Figures 3-7 disclose an annular damper 28 comprising a damper body 29 defining a damping volume 30 that is wrapped outside around the liner 7. The damper body 28 is spaced from the liner 7 in order to form a cooling gap 31 between the damper body 29 and the liner 7. The reference C in figures 3-7 refers to a cooling air, i.e. the compressed air delivered by the compressor in the plenum, passing in the cooling gap 31. A damper neck 32 connects the damping volume 30 with the combustion chamber 6 and acts as a bridge in the cooling gap 31 between the liner 7 and the damper

body 29.

**[0037]** As disclosed, the damper neck 32 may be welded to the liner 7 and the damper body 29 is connected or integral with the damper neck 32.

**[0038]** According to the embodiment of figures 3-4, the damper purge air P enters the damping volume 30 passing through a purge air inlet 33 realized on the outer wall of the damper body 29. Therefore, in this embodiment the purge air flow P is decoupled from the cooling air C passing through the cooling gap 31.

**[0039]** According to the embodiment of figures 5-6, the purge air inlet is realized in form of a gap 34 realized between the damper neck 32 and the damper body 29. In this embodiment, part of the cooling air C passing through the cooling gap 31 enters the damping volume 30 becomes the purge air P. Therefore, in this embodiment part of cooling air C passing through the cooling gap 31 enters the damping volume 30 acting as purge air flow P.

**[0040]** The figure 7 discloses an embodiment that can be considered as a hybrid of the foregoing embodiments of figures 4 and 6. Indeed, the embodiment of figure 7 is provided with two purge air inlets 33, 34 wherein the first purge air inlet 34 is located between the damper neck 32 and the damper body 29 and the second purge air inlet 33 is located on the outer wall of the damper body 29.

## Claims

1. A can combustor for a gas turbine (1), the can combustor (4) comprising:

- at least a burner (5, 20, 22);
- at least a liner (7, 26) downstream the burner (5, 20, 22) and defining an inner combustion chamber (6, 21, 23);
- a damper (28) comprising a damper body (29) defining a damping volume (30) wrapped outside around the liner (7, 26) and in fluid connection with the combustion chamber (6, 23); the damper body (29) being spaced from the liner (7, 26) in order to form a cooling gap (31) between the damper body (29) and the liner (7, 26) and limited by an inner surface of the damper body (29) facing an outer surface of the liner (7, 26), being present at least a damper neck (32) acting as a bridge in the cooling gap (31) between the liner (7, 26) and the damper body (29) for fluidly connecting the damping volume (30) with the combustion chamber (6, 23); **characterized in that** the cooling gap (31) between the damper body (29) and the liner (7, 26) is provided with a cooling device configured for increasing the heat transfer between the cooling air passing in the gap (31) and the liner (7, 26) and the damper body (29), the cooling device being arranged on the outer surface of the liner (7, 26)

and on the inner surface of the damper body (29).

2. Can combustor as claimed in claim 1, wherein the damper body (29) wraps the liner (7, 26) completely or in part.
3. Can combustor as claimed in claim 2 or 1, wherein the damping volume (30) is divided in a plurality of sub-volumes.
4. Can combustor as claimed in any one of the foregoing claims, wherein the damper (28) comprises a plurality of damper necks (32).
5. Can combustor as claimed in any one of the foregoing claims, wherein the damper (28) comprises at least a purge air inlet (33, 34) .
6. Can combustor as claimed in claim 5, wherein the purge air flow is decoupled from the cooling air passing through the cooling gap (31) and the purge air inlet (33) is located on the outer wall of the damper body (29).
7. Can combustor as claimed in claim 5, wherein part of the cooling air passing through the cooling gap (31) enters the damping volume acting as purge air flow.
8. Can combustor as claimed in claim 5, wherein the damper (28) comprises a purge air inlet (34) located on the inner wall of the damper body (29) facing the liner (7, 26) .
9. Can combustor as claimed in claim 8, wherein the purge air inlet (34) is located between the damper neck (32) and the damper body (29).
10. Can combustor as claimed in claim 8 or 9, wherein the damper (28) comprises a second purge air inlet (33) located on the outer wall of the damper body (29).
11. Can combustor as claimed in claim 1, wherein the cooling device comprises a plurality of trip strips arranged on the liner (7, 26) and/or on the damper body (29).
12. Can combustor as claimed in claim 1, wherein the cooling device comprises a plurality of turbolator elements arranged on the liner (7, 26) and/or on the damper body (29).
13. Can combustor as claimed in any one of the foregoing claims, wherein the can combustor (4) comprises in series a first burner (20), a first liner, a subsequent burner (22) and a subsequent liner (26); the damper

body (29) wrapping the subsequent liner (26).

14. A gas turbine for power plant; the gas turbine (1) having an axis (9) and comprising following the gas flow direction:

- a compressor sector (2) for compressing ambient air,
- a combustor (4) for mixing and combusting the compressed with at least a fuel
- at least a turbine (3) for expanding the combusted hot gas flow leaving the combustors (4) and performing work on a rotor (8);

wherein the combustor (4) is a can combustor according to any one of the foregoing claims.

### Patentansprüche

1. Rohrbrenner für eine Gasturbine (1), welcher Rohrbrenner (4) umfasst:

- mindestens einen Brenner (5, 20, 22);
- mindestens einen Einsatz (7, 26) stromabwärts des Brenners (5, 20, 22), der eine innere Brennkammer (6, 21, 23) bildet;
- einen Dämpfer (28), der einen Dämpferkörper (29) aufweist, der ein Dämpfungsvolumen (30) bildet, das den Einsatz (7, 26) außen umhüllt und mit der Brennkammer (6, 23) in Fluidverbindung steht; wobei der Dämpferkörper (29) von dem Einsatz (7, 26) beabstandet ist, um einen Kühlspalt (31) zwischen dem Dämpferkörper (29) und dem Einsatz (7, 26) zu bilden, der durch eine Innenfläche des Dämpferkörpers (29) begrenzt ist, die zu einer Außenfläche des Einsatzes (7, 26) weist, wobei zumindest ein Dämpferhals (32) vorhanden ist, der als eine Brücke in dem Kühlspalt (31) zwischen dem Einsatz (7, 26) und dem Dämpferkörper (29) zur Fluidverbindung des Dämpfungsvolumens (30) mit der Brennkammer (6, 23) wirkt;

**dadurch gekennzeichnet, dass** der Kühlspalt (31) zwischen dem Dämpferkörper (29) und dem Einsatz (7, 26) mit einer Kühleinrichtung versehen ist, die dafür konfiguriert ist, die Wärmeübertragung zwischen der durch den Spalt (31) tretenden Kühlluft und dem Einsatz (7, 26) und dem Dämpferkörper (29) zu steigern, wobei die Kühleinrichtung an der äußeren Oberfläche des Einsatzes (7, 26) und auf der inneren Oberfläche des Dämpferkörpers (29) angeordnet ist.

2. Rohrbrenner nach Anspruch 1, wobei der Dämpferkörper (29) den Einsatz (7, 26) vollständig oder teilweise umhüllt.

3. Rohrbrenner nach Anspruch 2 oder 1, wobei das Dämpfungsvolumen (30) in eine Vielzahl von Untervolumina unterteilt ist.

- 5 4. Rohrbrenner nach einem der vorstehenden Ansprüche, wobei der Dämpfer (28) eine Vielzahl von Dämpferhälsen (32) umfasst.

- 10 5. Rohrbrenner nach einem der vorstehenden Ansprüche, wobei der Dämpfer (28) mindestens einen Spüllufteinlass (33, 34) umfasst.

- 15 6. Rohrbrenner nach Anspruch 5, wobei der Spülluftstrom von der durch den Kühlspalt (31) tretenden Kühlluft entkoppelt ist und der Spüllufteinlass (33) an der Außenwand des Dämpferkörpers (29) angeordnet ist.

- 20 7. Rohrbrenner nach Anspruch 5, wobei ein Teil der durch den Kühlspalt (31) tretenden Kühlluft in das Dämpfungsvolumen eintritt und als Spülluftstrom dient.

- 25 8. Rohrbrenner nach Anspruch 5, wobei der Dämpfer (28) einen Spüllufteinlass (34) umfasst, der an der Innenwand des Dämpferkörpers (29) dem Einsatz (7, 26) gegenüberliegend angeordnet ist.

- 30 9. Rohrbrenner nach Anspruch 8, wobei der Spüllufteinlass (34) zwischen dem Dämpferhals (32) und dem Dämpferkörper (29) angeordnet ist.

- 35 10. Rohrbrenner nach Anspruch 8 oder 9, wobei der Dämpfer (28) einen zweiten Spüllufteinlass (33) umfasst, der an der Außenwand des Dämpferkörpers (29) angeordnet ist.

- 40 11. Rohrbrenner nach Anspruch 1, wobei die Kühleinrichtung eine Vielzahl von Störstreifen umfasst, die auf dem Einsatz (7, 26) und/oder auf dem Dämpferkörper (29) angeordnet sind.

- 45 12. Rohrbrenner nach Anspruch 1, wobei die Kühleinrichtung eine Vielzahl von Verwirbelungselementen umfasst, die auf dem Einsatz (7, 26) und/oder auf dem Dämpferkörper (29) angeordnet sind.

- 50 13. Rohrbrenner nach einem der vorstehenden Ansprüche, wobei der Rohrbrenner (4) in Reihe einen ersten Brenner (20), einen ersten Einsatz, einen nachfolgenden Brenner (22) und einen nachfolgenden Einsatz (26) umfasst, wobei der Dämpferkörper (29) den nachfolgenden Einsatz (26) umhüllt.

- 55 14. Gasturbine für ein Kraftwerk, welche Gasturbine (1) eine Achse (9) hat und der Gasflussrichtung folgend umfasst:

- einen Verdichterteil (2) zum Verdichten von Umgebungsluft,
- einen Brenner (4) zum Mischen und Verbrennen der verdichteten Luft mit mindestens einem Brennstoff,
- mindestens eine Turbine (3) zum Expandieren des aus den Brennern (4) austretenden verbrannten Heißgasstroms und zum Leisten von Arbeit an einem Rotor (8),

wobei der Brenner (4) ein Rohrbrenner nach einem der vorhergehenden Ansprüche ist.

## Revendications

1. Chambre de combustion tubulaire d'une turbine à gaz (1), la chambre de combustion tubulaire (4) comprenant :

- au moins un brûleur (5, 20, 22) ;
- au moins un revêtement (7, 26) en aval du brûleur (5, 20, 22), qui définit une chambre de combustion intérieure (6, 21, 23) ;
- un dispositif d'amortissement (28) comprenant un corps de dispositif d'amortissement (29) qui définit un volume d'amortissement (30) enroulé à l'extérieur autour du revêtement (7, 26), et en connexion de fluide avec la chambre de combustion (6, 23) ; le corps de dispositif d'amortissement (29) étant espacé du revêtement (7, 26) afin de former un intervalle de refroidissement (31) entre le corps de dispositif d'amortissement (29) et le revêtement (7, 26), et limité par une surface intérieure du corps de dispositif d'amortissement (29) faisant face à une surface extérieure du revêtement (7, 26), au moins un col de dispositif d'amortissement (32) étant présent et agissant en tant que passerelle dans l'intervalle de refroidissement (31) entre le revêtement (7, 26) et le corps de dispositif d'amortissement (29), afin de connecter par fluide le volume d'amortissement (30) et la chambre de combustion (6, 23) ; **caractérisée en ce que** l'intervalle de refroidissement (31) entre le corps de dispositif d'amortissement (29) et le revêtement (7, 26), est doté d'un dispositif de refroidissement configuré afin d'accroître le transfert de chaleur entre l'air de refroidissement qui passe dans l'intervalle (31) entre le revêtement (7, 26) et le corps de dispositif d'amortissement (29), le dispositif de refroidissement étant agencé sur la surface extérieure du revêtement (7, 26) et sur la surface intérieure du corps de dispositif d'amortissement (29).

2. Chambre de combustion tubulaire selon la revendication 1, dans laquelle le corps de dispositif d'amor-

tissement (29) enveloppe le revêtement (7, 26) en totalité ou en partie.

3. Chambre de combustion tubulaire selon la revendication 2 ou 1, dans laquelle le volume d'amortissement (30) est divisé en une pluralité de volumes secondaires.
4. Chambre de combustion tubulaire selon l'une quelconque des revendications précédentes, dans laquelle le dispositif d'amortissement (28) comprend une pluralité de cols de dispositif d'amortissement (32).
5. Chambre de combustion tubulaire selon l'une quelconque des revendications précédentes, dans laquelle le dispositif d'amortissement (28) comprend au moins une entrée d'air de purge (33, 34).
6. Chambre de combustion tubulaire selon la revendication 5, dans laquelle le flux d'air de purge est découplé à partir de l'air de refroidissement qui passe à travers l'intervalle de refroidissement (31), et l'entrée d'air de purge (33) se situe sur la paroi extérieure du corps de dispositif d'amortissement (29).
7. Chambre de combustion tubulaire selon la revendication 5, dans laquelle une partie de l'air de refroidissement qui passe à travers l'intervalle de refroidissement (31), pénètre dans le volume d'amortissement en agissant en tant que flux d'air de purge.
8. Chambre de combustion tubulaire selon la revendication 5, dans laquelle le dispositif d'amortissement (28) comprend une entrée d'air de purge (34) qui se situe sur la paroi intérieure du corps de dispositif d'amortissement (29) qui fait face au revêtement (7, 26).
9. Chambre de combustion tubulaire selon la revendication 8, dans laquelle l'entrée d'air de purge (34) se situe entre le col de dispositif d'amortissement (32) et le corps de dispositif d'amortissement (29).
10. Chambre de combustion tubulaire selon la revendication 8 ou 9, dans laquelle le dispositif d'amortissement (28) comprend une seconde entrée d'air de purge (33) qui se situe sur la paroi extérieure du corps de dispositif d'amortissement (29).
11. Chambre de combustion tubulaire selon la revendication 1, dans laquelle le dispositif de refroidissement comprend une pluralité de bandes de déclenchement agencées sur le revêtement (7, 26) et / ou sur le corps de dispositif d'amortissement (29).
12. Chambre de combustion tubulaire selon la revendication 1, dans laquelle le dispositif de refroidisse-

ment comprend une pluralité d'éléments turbulateurs agencés sur le revêtement (7, 26) et / ou sur le corps de dispositif d'amortissement (29).

- 13.** Chambre de combustion tubulaire selon l'une quelconque des revendications précédentes, dans laquelle la chambre de combustion tubulaire (4) comprend en série un premier brûleur (20), un premier revêtement, un brûleur ultérieur (22) et un revêtement ultérieur (26) ; le corps de dispositif d'amortissement (29) enveloppant le revêtement ultérieur (26). 5 10

- 14.** Turbine à gaz d'une centrale électrique ; la turbine à gaz (1) présentant un axe (9), et comprenant dans la direction de l'écoulement des gaz : 15

- un secteur compresseur (2) destiné à comprimer l'air ambiant,
- une chambre de combustion (4) destinée à mélanger et à brûler l'air comprimé avec au moins un combustible, 20
- au moins une turbine (3) destinée à expanser le flux de gaz chauds brûlés qui quitte les chambres de combustion (4), et à exécuter un travail sur un rotor (8) ; 25

dans laquelle la chambre de combustion (4) est une chambre de combustion tubulaire selon l'une quelconque des revendications précédentes. 30

35

40

45

50

55

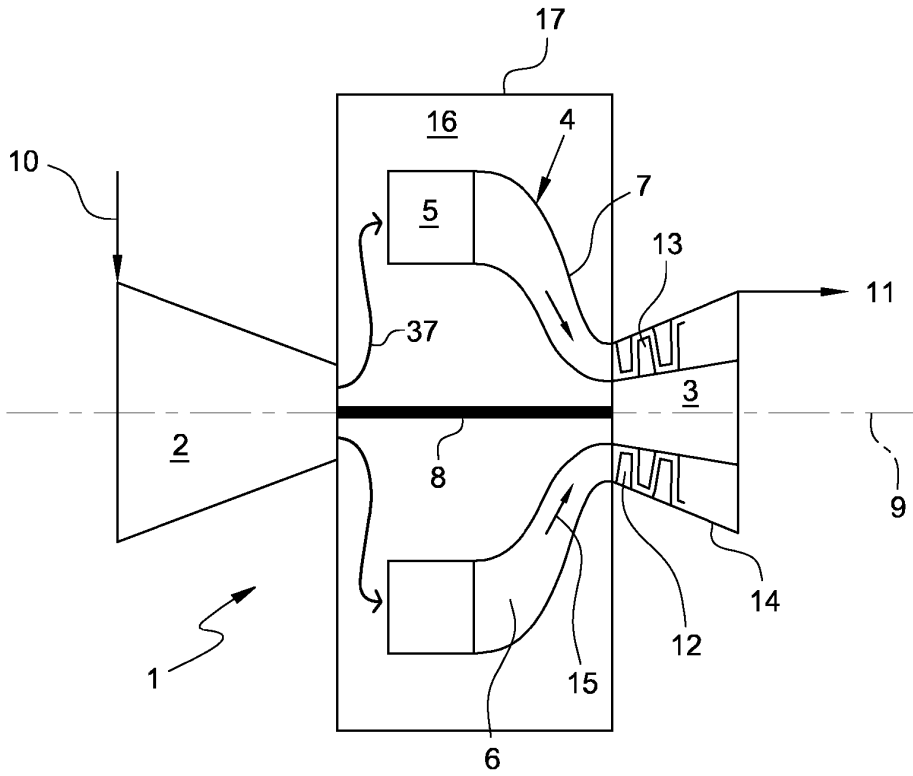

FIG. 1

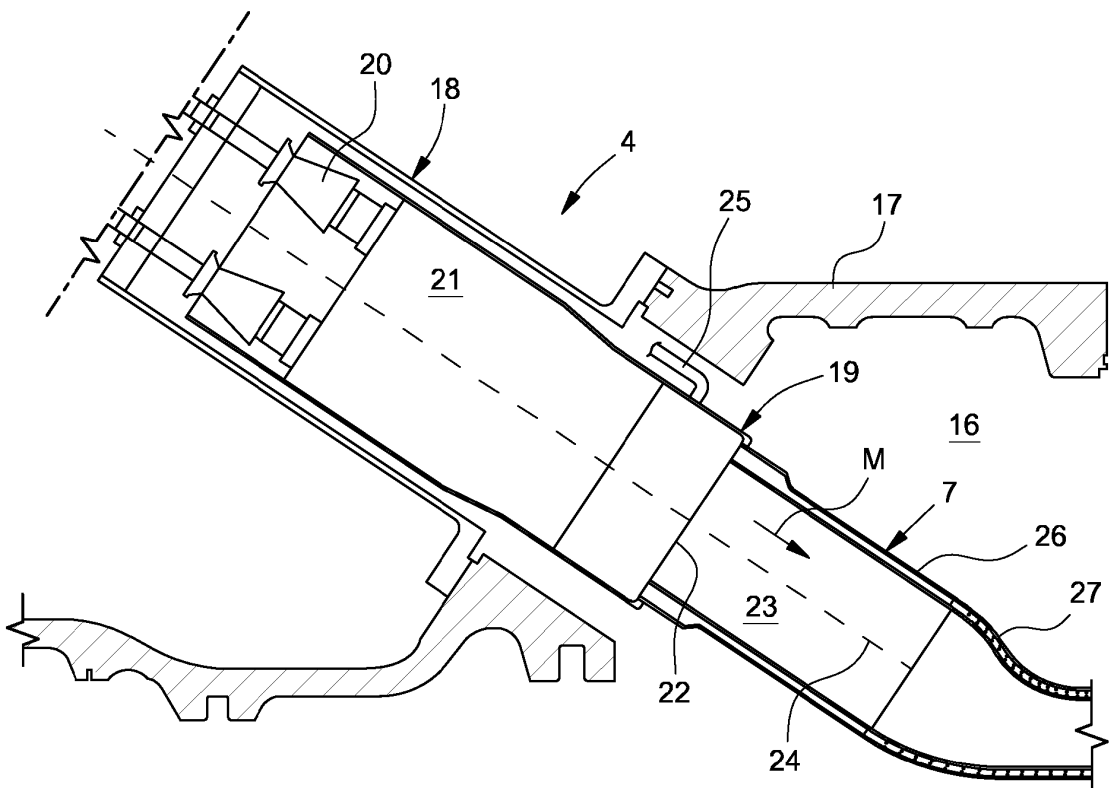

FIG. 2

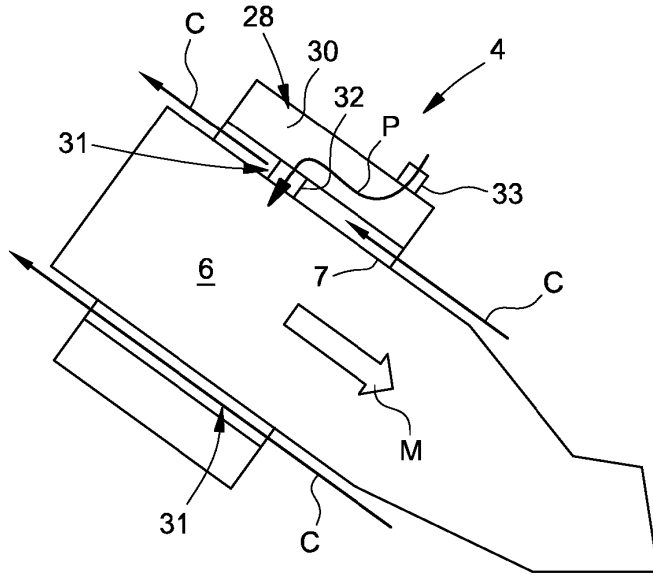

FIG. 3

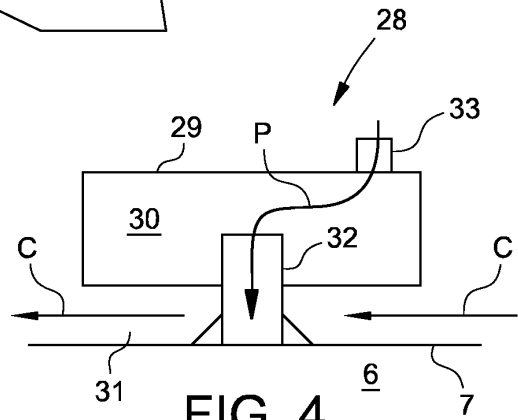

FIG. 4

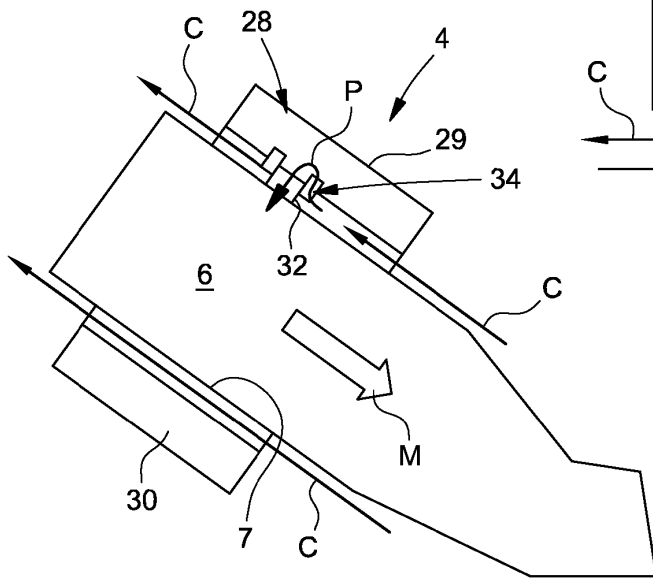

FIG. 5

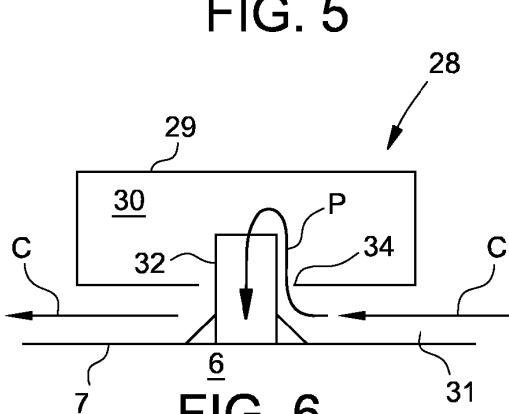

FIG. 6

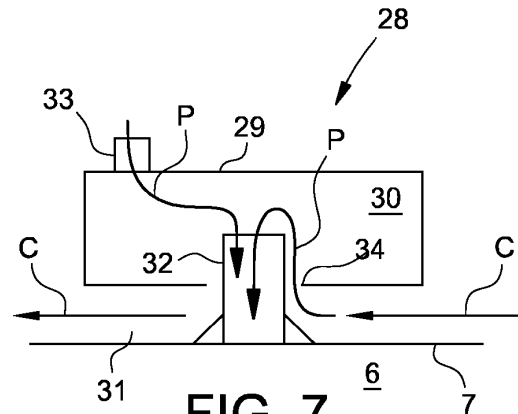

FIG. 7

**REFERENCES CITED IN THE DESCRIPTION**

*This list of references cited by the applicant is for the reader's convenience only. It does not form part of the European patent document. Even though great care has been taken in compiling the references, errors or omissions cannot be excluded and the EPO disclaims all liability in this regard.*

**Patent documents cited in the description**

- EP 17201899 [0001]
- US 8490744 B [0014]
- US 2016215984 A [0016]