



US011348278B2

(12) **United States Patent**
Chakravarty et al.

(10) **Patent No.:** **US 11,348,278 B2**

(45) **Date of Patent:** **May 31, 2022**

(54) **OBJECT DETECTION**

- (71) Applicant: **Ford Global Technologies, LLC**, Dearborn, MI (US)
- (72) Inventors: **Punarjay Chakravarty**, Campbell, CA (US); **Shubham Shrivastava**, Sunnyvale, CA (US); **Gaurav Pandey**, College Station, TX (US); **Xue Iuan Wong**, Dearborn, MI (US)
- (73) Assignee: **FORD GLOBAL TECHNOLOGIES, LLC**, Dearborn, MI (US)
- (*) Notice: Subject to any disclaimer, the term of this patent is extended or adjusted under 35 U.S.C. 154(b) by 0 days.

(58) **Field of Classification Search**

CPC ... G06T 7/73; G06T 3/40; G06T 2207/10028;
G06T 2207/30204; G06T 2207/30244;
G06T 2207/30256
See application file for complete search history.

(56) **References Cited**

U.S. PATENT DOCUMENTS

- 9,201,424 B1 12/2015 Ogale
 - 9,563,951 B2 2/2017 Okouneva
 - 9,804,594 B2 10/2017 Garipey et al.
 - 9,986,233 B1 5/2018 Curlander et al.
- (Continued)

Primary Examiner — Myron Wyche

(74) *Attorney, Agent, or Firm* — Frank A. MacKenzie;
Bejin Bieneman PLC

(21) Appl. No.: **17/016,874**

(22) Filed: **Sep. 10, 2020**

(65) **Prior Publication Data**

US 2022/0076441 A1 Mar. 10, 2022

(51) **Int. Cl.**

- G06T 7/73** (2017.01)
- G06T 3/40** (2006.01)
- G01S 13/42** (2006.01)
- G01S 17/42** (2006.01)
- G01S 17/86** (2020.01)
- G01S 13/86** (2006.01)

(52) **U.S. Cl.**

CPC **G06T 7/73** (2017.01); **G06T 3/40** (2013.01); **G01S 13/42** (2013.01); **G01S 13/867** (2013.01); **G01S 17/42** (2013.01); **G01S 17/86** (2020.01); **G06T 2207/10028** (2013.01); **G06T 2207/30204** (2013.01); **G06T 2207/30244** (2013.01); **G06T 2207/30256** (2013.01)

(57) **ABSTRACT**

A computing device is programmed to generate a plurality of raw 3D point clouds from respective sensors having non-overlapping fields of view, scale each of the raw point clouds including scaling real-world dimensions of one or more features included in the respective raw 3D point cloud, determine a first transformation matrix that transforms a first coordinate system of a first scaled 3D point cloud of a first sensor to a second coordinate system of a second scaled 3D point cloud of a second sensor, and determine a second transformation matrix that transforms a third coordinate system of a third scaled 3D point cloud of a third sensor to the second coordinate system of the second scaled 3D point cloud of the second sensor. The computing device is programmed, based on the first and second transformation matrices, upon detecting an object in a first or third camera field of view, determine location coordinates of the object relative to a coordinate system that is defined based on the second coordinate system; and output the determined location coordinates of the object.

16 Claims, 10 Drawing Sheets

410

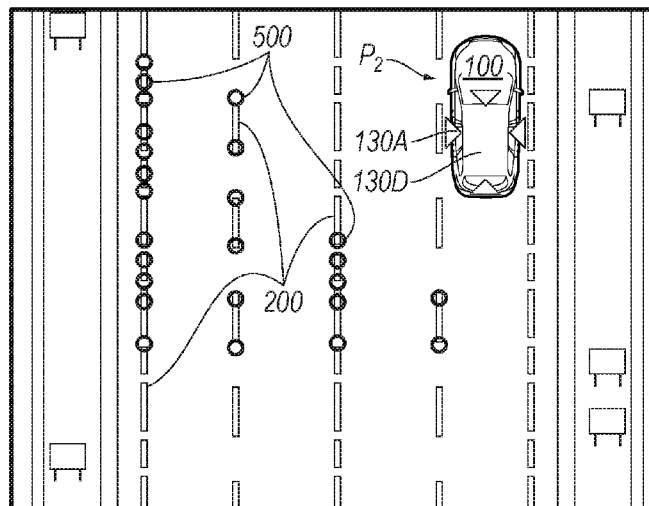

(56)

References Cited

U.S. PATENT DOCUMENTS

10,430,970	B2	10/2019	Bier	
2017/0299404	A1*	10/2017	Wang	G06T 7/80
2019/0295266	A1*	9/2019	Fan	G06T 7/38
2020/0160546	A1*	5/2020	Gu	G06N 3/08
2020/0211226	A1*	7/2020	Kundu	G06K 9/00818

* cited by examiner

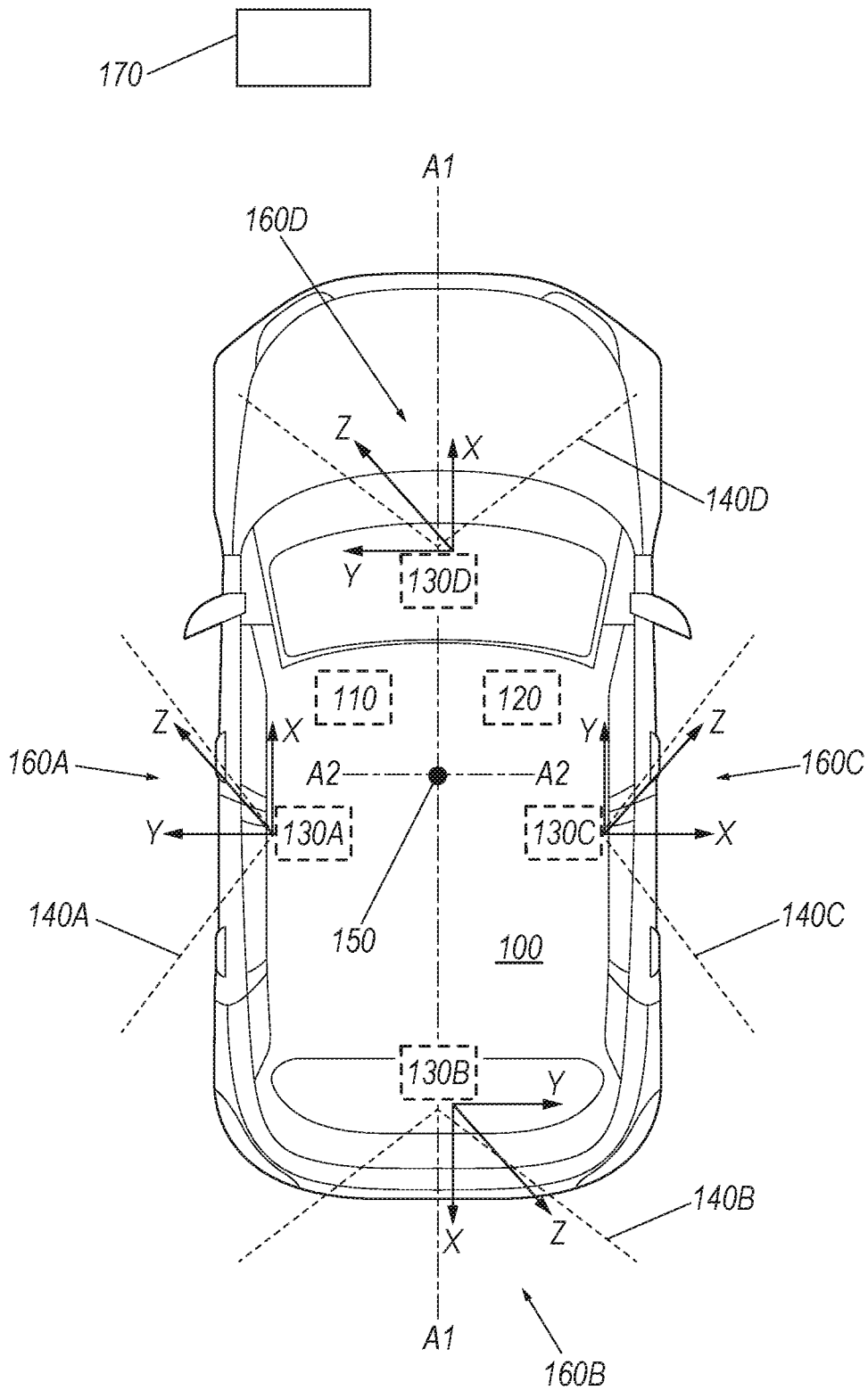

FIG. 1

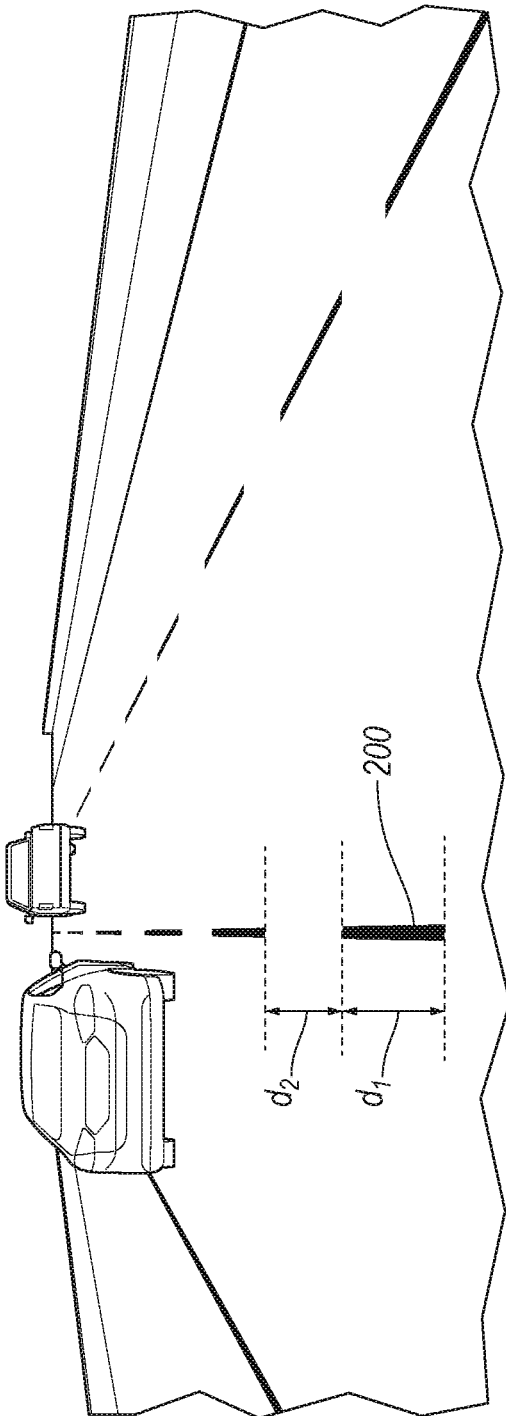

FIG. 2

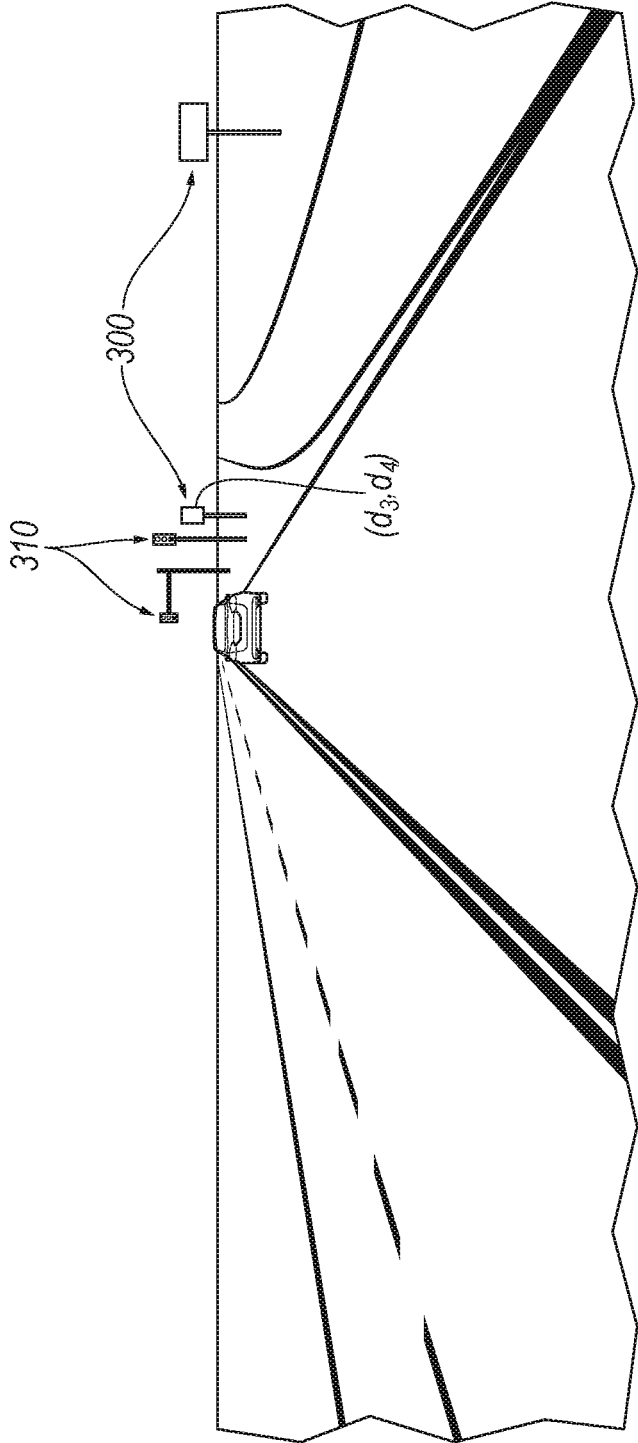

FIG. 3

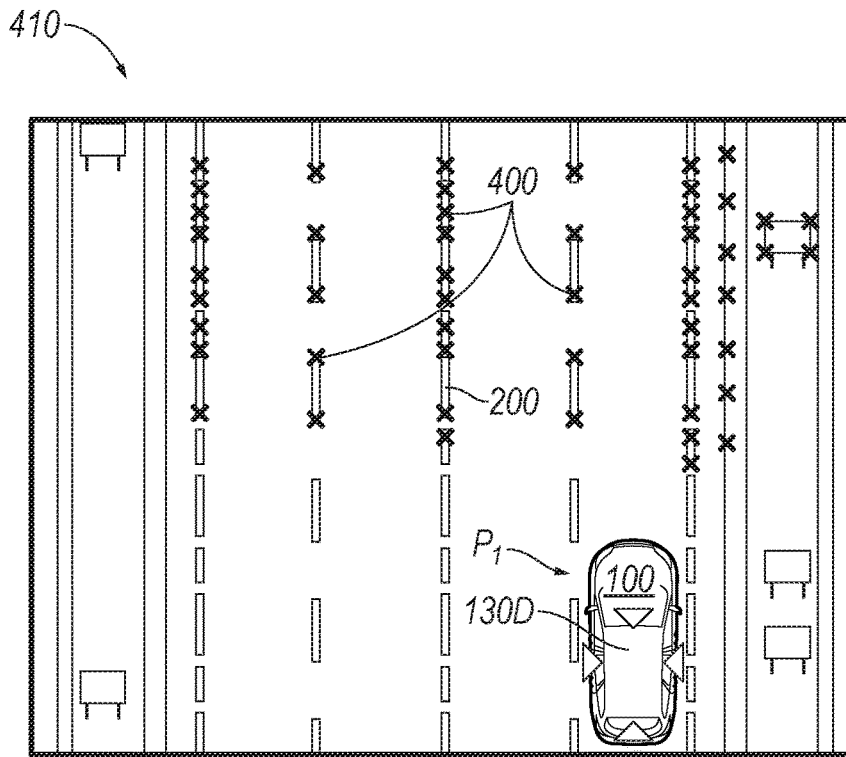

FIG. 4A

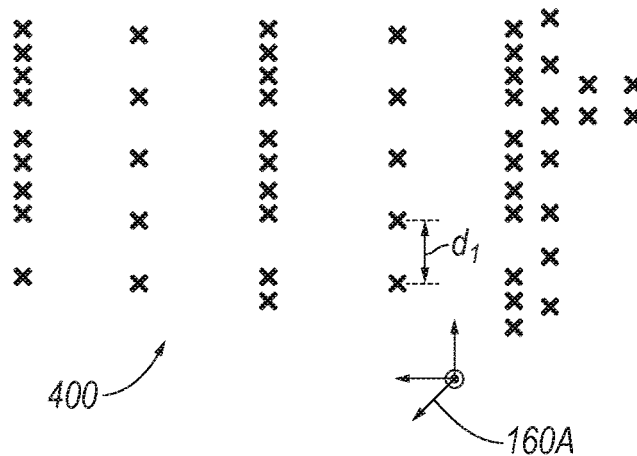

FIG. 4B

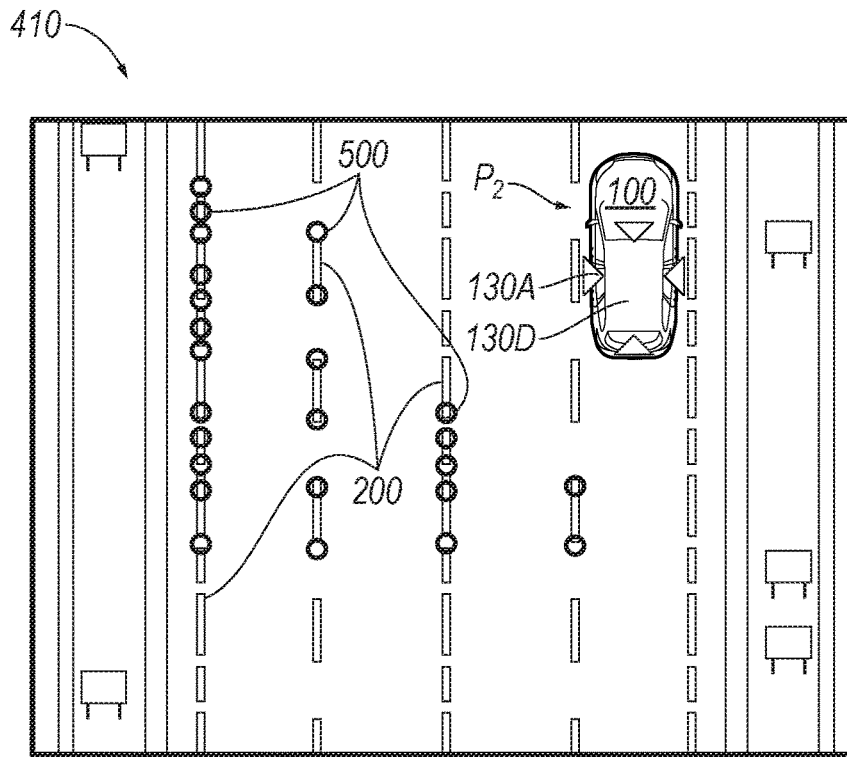

FIG. 5A

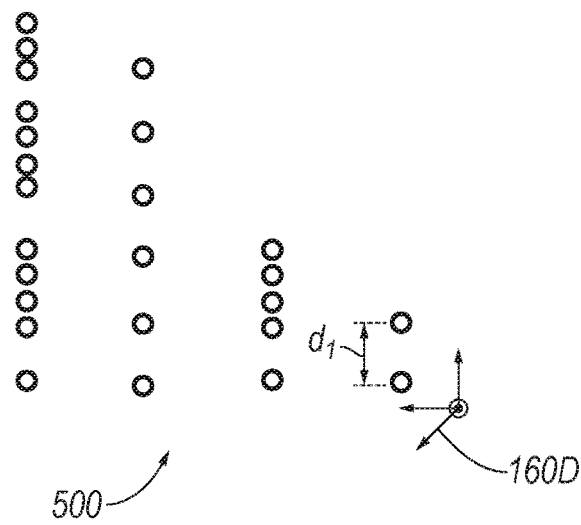

FIG. 5B

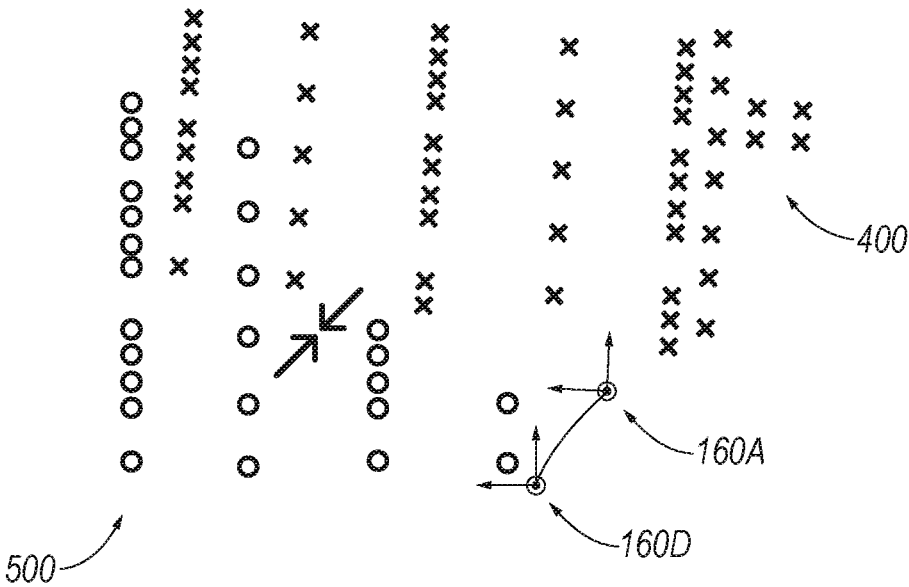

FIG. 6

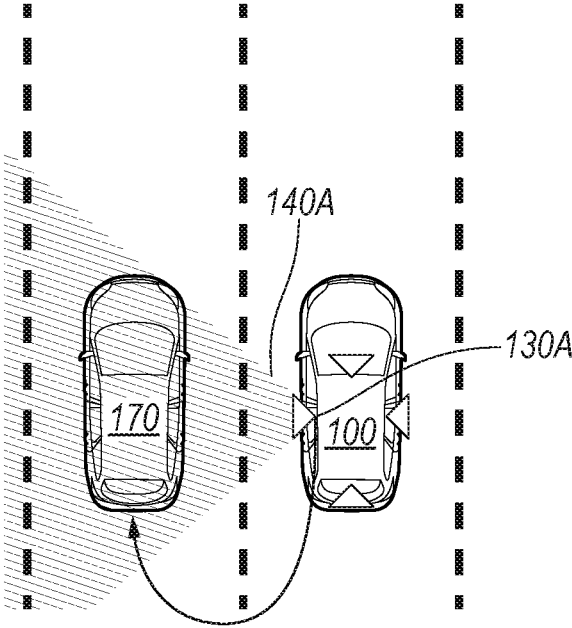

FIG. 7A

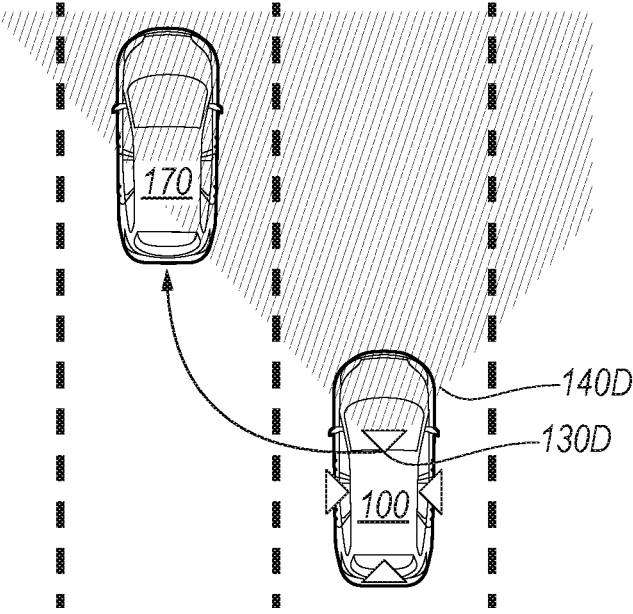

FIG. 7B

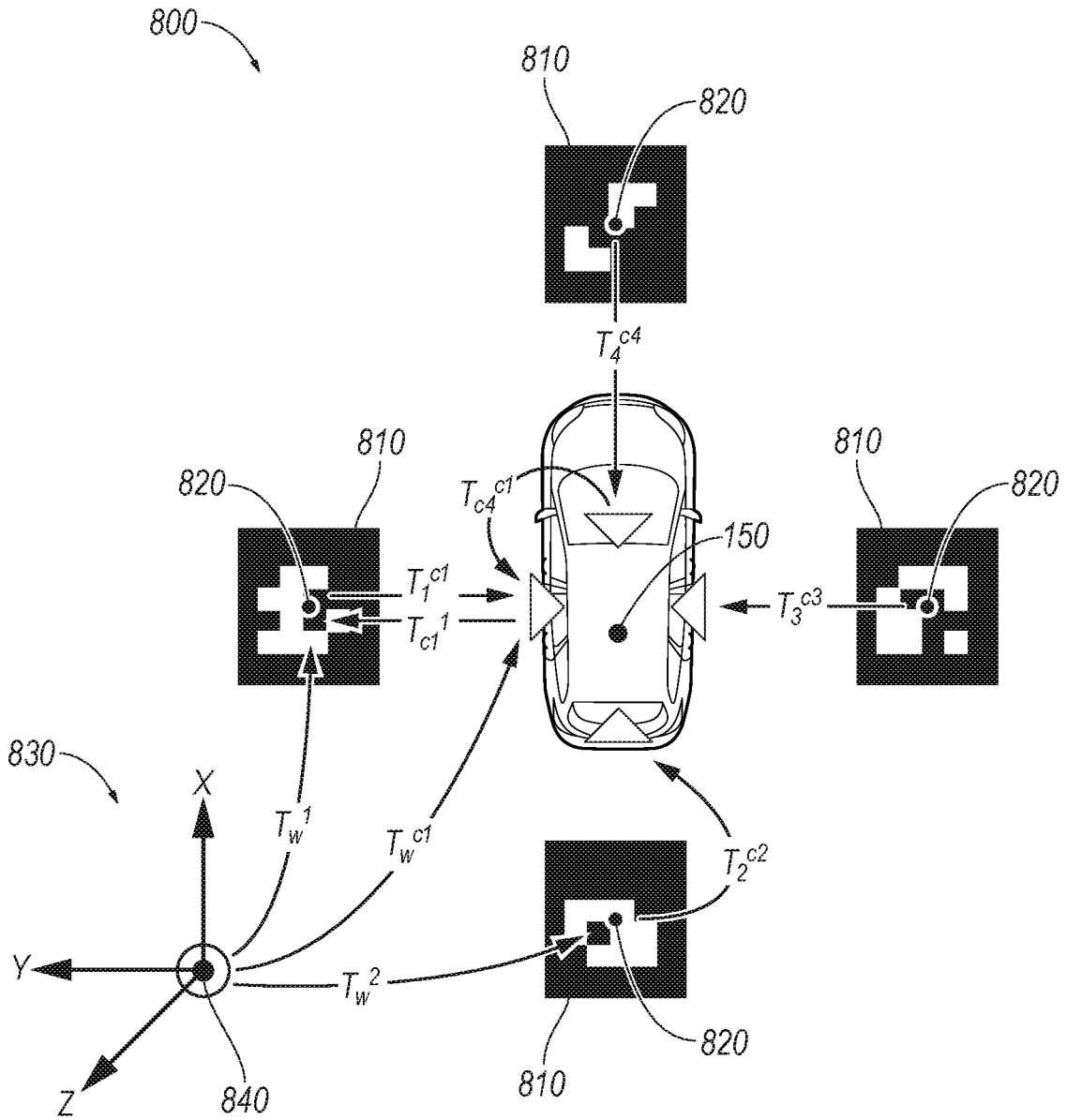
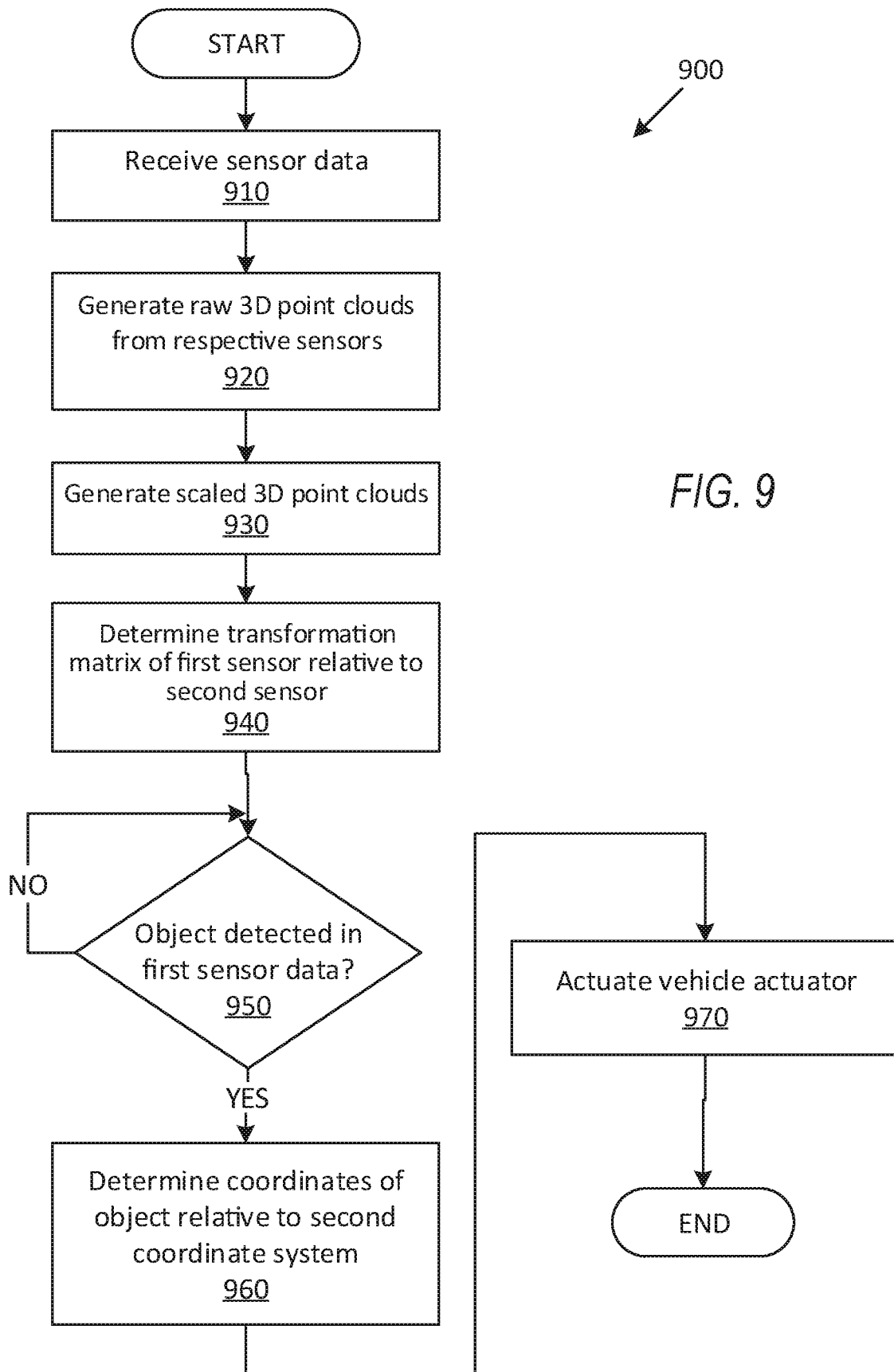

FIG. 8



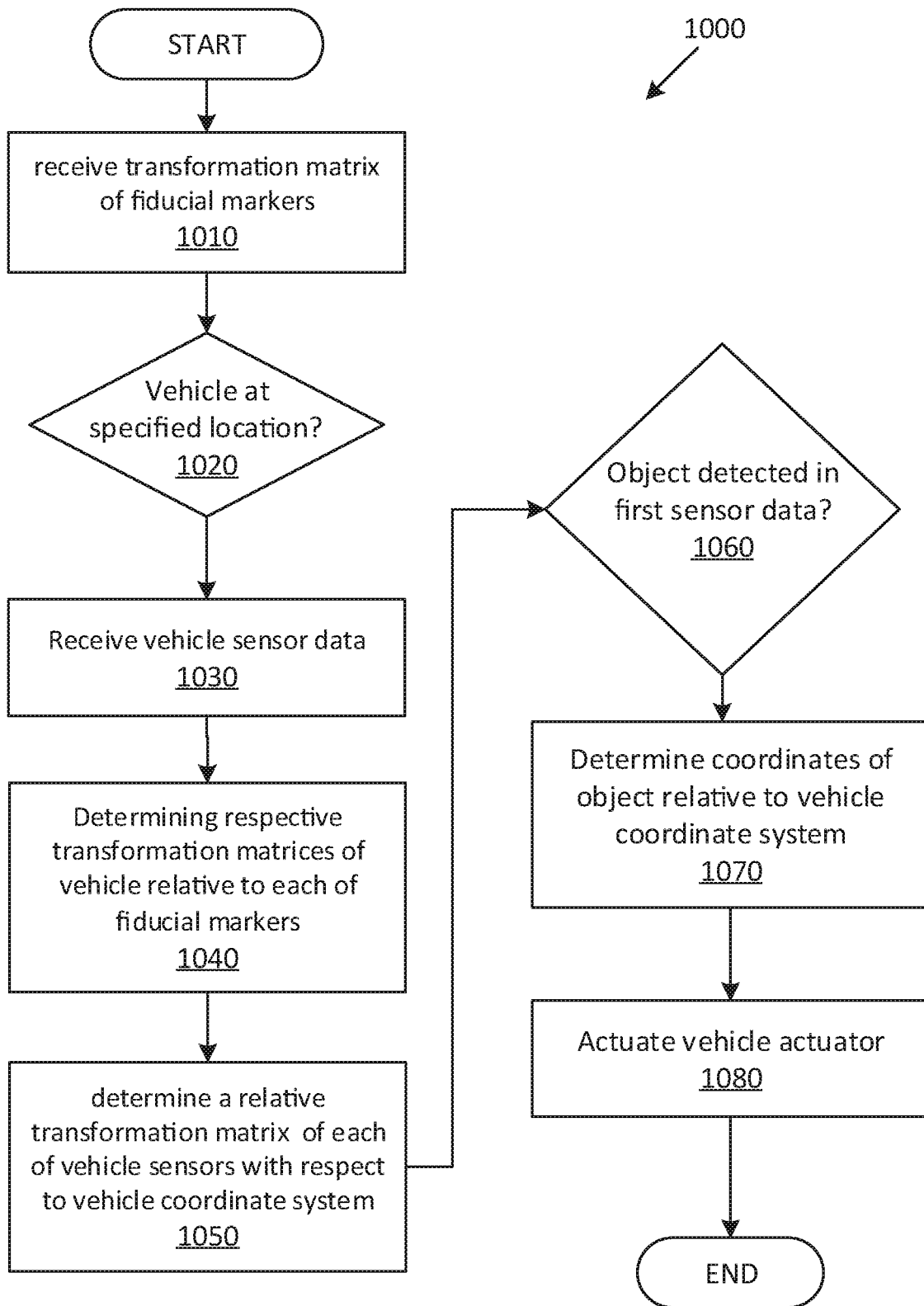

FIG. 10

1

OBJECT DETECTION

BACKGROUND

One or more computers in an autonomous vehicle (or self-driving car) can be programmed to navigate and operate the vehicle based on vehicle sensor data. The vehicle computers may rely on sensor data, e.g., camera data, etc., to detect objects. Different sensors can provide data from different fields of view. Fusion of data from multiple sensors is a technical challenge.

BRIEF DESCRIPTION OF THE DRAWINGS

FIG. 1 is a block diagram showing an example vehicle including sensors detecting an object.

FIG. 2 is an example image received from a camera sensor of the vehicle of FIG. 1.

FIG. 3 is another example image received from the camera sensor showing dimensions determined from HD (High Definition) map data.

FIG. 4A illustrates a top view of a point cloud, generated from front camera sensor data, illustrating detected road feature points.

FIG. 4B illustrates the feature points of FIG. 4A.

FIG. 5A illustrates a top view of another point cloud, generated from side camera sensor data, illustrating detected road feature points.

FIG. 5B illustrates the feature points of FIG. 5A.

FIG. 6 illustrates an example of matching feature points of FIGS. 4B and 5B.

FIG. 7A shows an object within a side camera sensor field of view of the vehicle of FIG. 1.

FIG. 7B shows the object of FIG. 7A within the field of view of the front camera sensor of the vehicle of FIG. 1.

FIG. 8 shows the vehicle of FIG. 1 at a specified location with fiducial markers for extrinsic calibration.

FIG. 9 is a flowchart of an example process for performing extrinsic calibration of vehicle camera sensors based on road features, and operating the vehicle.

FIG. 10 is a flowchart of an example process for performing extrinsic calibration of vehicle camera sensors based on fiducial markers at a specified location, and operating the vehicle.

DETAILED DESCRIPTION

Introduction

Disclosed herein is a computing device comprising a processor and a memory. The memory stores instructions executable by the processor to generate a plurality of raw 3D point clouds from respective sensors having non-overlapping fields of view, to scale each of the raw point clouds including scaling real-world dimensions of one or more features included in the respective raw 3D point cloud, and to determine a first transformation matrix that transforms a first coordinate system of a first scaled 3D point cloud of a first sensor to a second coordinate system of a second scaled 3D point cloud of a second sensor. The memory stores instructions to determine a second transformation matrix that transforms a third coordinate system of a third scaled 3D point cloud of a third sensor to the second coordinate system of the second scaled 3D point cloud of the second sensor, based on the first and second transformation matrices, upon detecting an object in a first or third camera field of view, to determine location coordinates of the object relative to a

2

coordinate system that is defined based on the second coordinate system, and to output the determined location coordinates of the object.

The instructions may further include instructions to generate the raw 3D point clouds by applying monocular visual odometry technique to image data received from the respective sensor.

Each of the plurality of 3D point clouds may be generated based on data received from one of a plurality of sensors.

The one or more features may include at least one of a lane marking, a guardrail, a traffic sign, and a traffic light, and wherein the real-world dimensions may be determined based on at least one of (i) received HD map data or (ii) a set of specified dimensions including distances between two or more road markings, and dimensions of the traffic sign.

The instructions may further include instructions to determine the first transformation matrix by matching one or more features between the first and second 3D point clouds from the plurality of scaled 3D point clouds, thereby determining a first sensor pose relative to a second sensor pose; the second coordinate system defined based on the second sensor pose.

The instructions may further include instructions to determine the second transformation matrix by matching one or more features between a third scaled 3D point cloud and the second scaled 3D point clouds from the plurality of raw 3D point clouds, thereby generating a third sensor pose relative to the second sensor pose; the second coordinate system defined based on the second sensor pose.

Further disclosed herein is a computing device comprising a processor and a memory. The memory stores instructions executable by the processor to receive a transformation matrix of each of a plurality of stationary fiducial markers at a plurality of locations, based on receiving image data from each of a plurality of sensors, each image including image data including at least one of the fiducial markers, to determine respective transformation matrices of a vehicle relative each of the fiducial markers, wherein each of the sensors is included on the vehicle and wherein the sensors have non-overlapping fields of view, to determine a relative transformation matrix of each of the sensors with respect to a vehicle coordinate system having an origin at a vehicle reference point, upon receiving the image data including an object from at least one of the sensors, to determine transformation matrix of the object relative to the vehicle coordinate system, and to actuate a vehicle actuator based on the object.

The instructions may further include instructions to determine the relative transformation matrix of each of the sensors with respect to the vehicle coordinate system by performing a pose concatenation.

The received transformation matrix of each of a plurality of stationary fiducial markers at a plurality of locations may be defined relative to a second coordinate system outside the vehicle, and each pose includes roll, pitch, yaw, lateral, longitudinal, and elevation coordinates.

Each of the fiducial markers may be an Aruco marker.

The instructions may further include instructions to determine transformation matrix of the object relative to a coordinate system that is defined based on a second coordinate system by performing a pose concatenation, wherein the pose concatenation is a result of a matrix dot product operation on a first matrix specifying object coordinates relative to a first camera and a second transformation matrix specifying a pose and coordinates of the first camera relative to the second coordinate system.

Further disclosed herein is a method, comprising generating a plurality of raw 3D point clouds from respective sensors having non-overlapping fields of view, scaling each of the raw point clouds including scaling real-world dimensions of one or more features included in the respective raw 3D point cloud, determining a first transformation matrix that transforms a first coordinate system of a first scaled 3D point cloud of a first sensor to a second coordinate system of a second scaled 3D point cloud of a second sensor, determining a second transformation matrix that transforms a third coordinate system of a third scaled 3D point cloud of a third sensor to the second coordinate system of the second scaled 3D point cloud of the second sensor, based on the first and second transformation matrices, upon detecting an object in a first or third camera field of view, determining location coordinates of the object relative to a coordinate system that is defined based on the second coordinate system, and outputting the determined location coordinates of the object.

The method may further include generating the raw 3D point clouds by applying monocular visual odometry technique to image data received from the respective sensor, wherein each of the plurality of 3D point clouds is generated based on data received from one of a plurality of sensors.

The one or more features may include at least one of a lane marking, a guardrail, a traffic sign, and a traffic light, and wherein the real-world dimensions are determined based on at least one of (i) received HD map data or (ii) a set of specified dimensions including distances between two or more road markings, and dimensions of the traffic sign.

The method may further include determining the first transformation matrix by matching one or more features between the first and second 3D point clouds from the plurality of scaled 3D point clouds, thereby determining a first sensor pose relative to a second sensor pose; the second coordinate system defined based on the second sensor pose.

The method may further include determining the second transformation matrix by matching one or more features between a third scaled 3D point cloud and the second scaled 3D point clouds from the plurality of raw 3D point clouds, thereby generating a third sensor pose relative to the second sensor pose; the second coordinate system defined based on the second sensor pose.

Further disclosed is a computing device programmed to execute any of the above method steps.

Yet further disclosed is a computer program product, comprising a computer readable medium storing instructions executable by a computer processor, to execute any of the above method steps.

System Elements

Navigation of a land vehicle, e.g., an autonomous or semi-autonomous vehicle, may be based on sensor data about objects, e.g., data including location(s), dimensions, types or classes, etc., of objects. A vehicle computer may receive data from multiple sensors from which objects may be detected and/or described, e.g., camera sensors, lidar (light imaging detection and ranging) sensors, etc., and operate the vehicle based on a result of fusing data received from multiple sensors. Data fusion means combining multiple data sources about a field of view, thereby taking advantage of data obtained via various sensed media, and typically providing more consistent, accurate, and useful information than that provided by any one of the data sources alone.

Problem can arise in fusing data from multiple sensors, e.g., where difference sensors are governed by different parameters, e.g., utilize different media, have different fields

of view, etc. Even different sensors in a same medium can present data fusion problems due to differences between parameters, e.g., resolution of data, sensor field of view, etc. For example, a vehicle computer may detect an object in a first location with first dimensions based on data from a first camera, while detecting the object in a second location with second dimensions different from the first location and/or the first dimensions based on data received from a second camera. Fusing data from such first and second cameras to present reliable data about an object with respect to a vehicle present challenges.

Advantageously as disclosed herein, to operate a vehicle based on data from multiple sensors, extrinsic calibration parameters can be determined. Extrinsic calibration parameters specify a transformation of coordinates (or transformation matrix) from a first sensor coordinate system to a second sensor coordinate system.

To improve sensor data fusion and provide more efficient and accurate recognition and description of objects and/or an environment, a computer may be programmed to generate a plurality of raw 3D point clouds from respective 2D image sensors having non-overlapping fields of view, and to scale each of the raw point clouds, including scaling real-world dimensions of one or more features included in the respective raw 3D point cloud. The computer may be programmed to determine a first transformation matrix that transforms a first coordinate system of a first scaled 3D point cloud of a first sensor to a second coordinate system of a second scaled 3D point cloud of a second sensor. The computer may be further programmed to determine a second transformation matrix that transforms a third coordinate system of a third scaled 3D point cloud of a third sensor to the second coordinate system of the second scaled 3D point cloud of the second sensor. The computer may be further programmed, based on the first and second transformation matrices, upon detecting an object in a first or third camera field of view, to determine location coordinates of the object relative to a coordinate system that is defined based on the second coordinate system, and to output the determined location coordinates of the object. A transformation matrix includes (i) pose (roll, pitch, and heading) and (ii) location coordinates (lateral, longitudinal, and elevation) of an object or coordinate system relative to another coordinate system. A “feature” in or of an environment, in the present context, means a physical structure in the environment, i.e., a physical object, surface, or marking, e.g., a building, pole, traffic sign, bridge, road surface, vegetation, guardrail, and/or patterns or markings physically applied to other physical structures in the environment, e.g., a painted lane marking, etc.

FIG. 1 illustrates an example host vehicle **100** including a computer **110**, actuator(s) **120**, and multiple object detection sensors such as camera sensors **130A**, **130B**, **130C**, **130D** with fields of view **140A**, **140B**, **140C**, **140D**. In the present context, a camera sensor **130** with a field of view **140** may be any of the example camera sensors **130A**, **130B**, **130C**, **130D** with a respective field of view **140A**, **140B**, **140C**, **140D**. In one example shown in FIG. 1, the camera sensors **130A**, **130B**, **130C**, **130D** may be directed to left, rear, right, and front direction of the vehicle **100**.

In one example, as shown in FIG. 1, the camera sensors **130** may be mounted within a predetermined distance, e.g., 10 centimeter (cm), from one another in different directions. A reference point such as a geometrical center point **150** can be specified for a vehicle **100**, e.g., a point at which respective longitudinal and lateral centerlines of the vehicle **100** intersect. A vehicle **100** body may have a longitudinal

axis **A1** and one or more lateral axes **A2**. The vehicles **100** may be powered in a variety of known ways, e.g., with an electric motor and/or internal combustion engine.

The computer **110** (or computing device) includes a processor and a memory such as are known. The memory includes one or more forms of computer-readable media, and stores instructions executable by the computer **110** for performing various operations, including as disclosed herein.

The computer **110** may operate the vehicle **100** in an autonomous or semi-autonomous mode. For purposes of this disclosure, an autonomous mode is defined as one in which each of vehicle **100** propulsion, braking, and steering are controlled by the computer **110**; in a semi-autonomous mode, the computer **110** controls one or two of vehicle **100** propulsion, braking, and steering.

The computer **110** may include programming to operate one or more of vehicle brakes, propulsion (e.g., control of acceleration in the vehicle by controlling one or more of an internal combustion engine, electric motor, hybrid engine, etc.), steering, climate control, interior and/or exterior lights, etc., as well as to determine whether and when the computer **110**, as opposed to a human operator, is to control such operations.

The computer **110** may include or be communicatively coupled to, e.g., via a vehicle communications bus as described further below, more than one processor, e.g., controllers or the like included in the vehicle for monitoring and/or controlling various vehicle controllers, e.g., a powertrain controller, a brake controller, a steering controller, etc. The computer **110** is generally arranged for communications on a vehicle communication network such as a bus in the vehicle such as a controller area network (CAN) or the like.

Via the vehicle network, the computer **110** may transmit messages to various devices in the vehicle and/or receive messages from the various devices, e.g., the sensors **130**, actuators **120**, etc. Alternatively or additionally, in cases where the computer **110** actually comprises multiple devices, the vehicle communication network may be used for communications between devices represented as the computer **110** in this disclosure. Further, as mentioned below, various controllers and/or sensors may provide data to the computer **110** via the vehicle communication network.

The actuators **120** may be implemented via circuits, chips, or other electronic components that can actuate various vehicle subsystems in accordance with appropriate control signals as is known. The actuators **120** may be used to control braking, acceleration, and steering of the vehicle **100**. As an example, the vehicle **100** computer **110** may output control instructions to control the actuators **120**.

The vehicle **100** sensors **130** may provide data encompassing at least some of an exterior of the vehicle **100**, e.g., a camera, radar, and/or lidar (light imaging detection and ranging). For example, a camera sensor **130** may provide object detection, i.e., data including dimensions, relative location, etc., of objects **170** outside the vehicle **100** within a field of view **140** of the sensor **130**. For example, locations relative to a vehicle **100** can be specified with respect to two or three axes of a three-dimensional Cartesian coordinate system **160**, e.g., according to (x, y, z) coordinates. The coordinate system **160** may be a Cartesian coordinate system in an origin such as a point on or in the respective sensor **130**. In one example, each coordinate system **160** has an origin at a specified point, e.g., a center of a lens, a geometrical center, etc., of the respective sensor **130**.

A reference point **150**, e.g., an intersection of the longitudinal axis **A1** and a lateral axis **A2** could be at a reference location with defined with respect to the vehicle **100**. The computer **110** may be programmed to determine the location, dimensions, etc., of an object **170** within a field of view **140** of a specific sensor **130** based on data received from the camera sensor **130** relative to the respective coordinate system **160** defined with respect to the sensor **130**.

A camera sensor **130** provides image data to, e.g., the vehicle **100** computer **110**. The camera sensor(s) may include chips, image sensors, and optical components. The camera sensor(s) **130** may output image data based on the optical signals captured by the image sensor(s) of the camera sensor **130**. The computer **110** may be programmed to detect object(s) **170** from image data received from the camera sensor(s) **130** and determine dimension(s) and/or location of the object(s) **170**, e.g., with respect to the coordinate system **160** of the respective sensor **130**.

Object(s) **170** may be a second vehicle, bicycle, truck, pedestrian, building, traffic sign, wall, light pole, etc., within a field of view **140** of a respective sensor **130**. An object **170** is a real-world, i.e., physical, object. Real-world data about an object **170** is herein referred to as ground truth data. That is, ground truth data is data that sensors **130** would obtain if sensors **130** were perfect and could provide a perfect, true representation of an environment without any errors or lags in communication or measurement. It is desirable for sensors **130** to provide data from which a computer **110** can determine data representing an object **170** that is as close to ground truth data as possible (i.e., a best possible approximation of real-world object). Further, in the present context, a field of view **140** is an area of the ground surface (e.g., the horizontal plane **210**) in which objects **170** can be detected by the sensors **130**.

The fields of view **140** of sensors **130** can be non-overlapping, as in examples herein. "Non-overlapping" fields of view mean that (i) no portion of an environment exterior to the vehicle **100** is included in data received from more than one sensor **130**, or (ii) a portion of the environment exterior to the vehicle **100** is present in data from two sensors **130**, but an object **170** within the portion of the environment detected by the two sensors **130** is detectable based on data from only one of the two sensors **130**. In other words, fields of view of sensors **130** are considered to be non-overlapping when any two sensors **130** provide data from an overlapping area but the amount of the data (e.g., width angle of overlapping area) from the overlapping area is insufficient for one of the sensors to detect an object **170** independently from data from at least the other sensor **130**. For example, a horizontal width angle of overlapping area may be 5 degrees with respect to a reference line on the ground surface. Thus, an object **170** may not fit in the overlapping area of the image data, and therefore the computer **110** may lack the ability to detect the object **170** only based on the image data of the overlapping area.

The computer **110** may be programmed to operate the vehicle **100** based on data received from the vehicle **100** sensor(s) **130**. The computer **110** may be programmed to actuate a vehicle **100** actuator **120**, e.g., to operate braking, steering, and/or propulsion, based on the received sensor **130** data.

The computer **110** can be programmed to generate a plurality of raw 3D (three-dimensional) point clouds from respective sensors **130** having non-overlapping fields of view **140**. A 3D point cloud is a 3D representation of an environment formed by acquiring distance or range measurements between an object detection sensor **130** and points

in an environment (e.g., using techniques such as discussed further below), typically including data points describing objects **170** and/or surfaces, e.g., a road surface detected based on data received from an object detection sensor **130**. A 3D point cloud includes 3D location coordinates of points on surfaces of object(s) **170**, road, etc. In the present context, a “raw” 3D point cloud specifies a representation of a 3D environment, e.g., an exterior of the vehicle **100** including any objects in the environment. The raw 3D point cloud is unscaled, i.e., lacks reference to real-world dimensions of objects **170** (i.e., e.g., a real-world, i.e., actual physical, length or width of an object **170**). A scale, in this context, is a ratio of real-world distances compared to point cloud distances, e.g., specified in pixels. For example, a scale may specify that 1 pixel corresponds to 10×10 square centimeters (cm²). “Scaling” means determining a ratio between real-world dimensions and dimensions of the point cloud.

For example, the computer **110** may generate a first raw 3D point cloud based on data received from the first sensor **130A**, a second raw 3D point cloud based on data received from the second sensor **130B**, a third raw 3D point cloud based on data received from the third sensor **130C**, and a fourth raw 3D point cloud based on data received from the fourth sensor **130D**. Data received from a camera sensor **130** is typically 2D (two-dimensional). Techniques such as a Visual Odometry (VO), bundle adjustment, etc., may be used to generate the raw 3D point clouds based on, e.g., grayscale 2D, data received from each of the camera sensor **130**. In other words, each raw 3D point cloud is generated based on data from one of the camera sensors **130**.

In monocular Visual Odometry, features such as object(s) **170** are detected in a camera sensor **130** field of view **140**, and while the camera sensor **130** moves, e.g., based on a vehicle **100** movement, the detected features are matched over time. As discussed below with respect to FIGS. **4B**, **5B**, and **6**, this process is referred to “matching,” i.e., finding images of a same feature in images from different cameras. “Matching over time” means finding a feature in a first image at a time t_1 and then finding same feature viewed from a different field of view in a second image captured at time t_2 . The computer **110** may be programmed to triangulate according to a parallax technique between a first position of the camera sensor **130**, a second position of the camera sensor **130**, and a position of a feature. A “parallax,” as will be understood, is a displacement or difference in an apparent position of an object viewed along two different lines of sight. The term “monocular,” in the present context, refers to use of only one camera sensor **130** to provide data in generating the raw 3D point cloud. For example, the computer **110** may be programmed, based on Equation (1) below, to estimate a relative location t and a relative pose R between different positions of a camera sensor **130** by minimizing an error E of point to point projection between the images received from the camera sensor **130**.

$$E = \min_{R_i, t_i, X_j} \sum \|d_{i,j} - \prod (R_i X_j + t_i)\|^2 \quad (1)$$

A pose R specifies roll, pitch, and yaw of an object relative to a reference coordinate system. In one example, a pose R can specify a roll, pitch, and yaw of a first coordinate system relative to a second coordinate system. Thus, a pose R is an orthonormal rotation matrix parametrized by the Euler angles $[\varphi, \theta, \psi]^T$. Parameters φ, θ, ψ represent an angle between the coordinate system **160A**, **160B**, i.e., a roll,

pitch, and heading respectively. The location parameter $t=[x, y, z]^T$ is a translation vector that provides a translation between the first and second locations of the coordinate system **160** of the camera sensor **130**. Vectors u represent 2D features, e.g., object(s) **170**, based on image pixel locations. For example, vector $u[i,j]$ represent image plane position of features, wherein i and j are row and column coordinates of a feature. Additionally or alternatively, a feature may be a corner feature, a SIFT (scale-invariant feature transform), a SURF (speeded up robust features), and/or any other kind of learned feature which may be tracked frame to frame. Vector X represent 3D location of the features.

As discussed above, the raw 3D point cloud lacks a scale, i.e., a reference to dimensions of the real (i.e., physical) world. With reference to FIGS. **2-3**, the computer **110** can be programmed to scale each of the raw 3D point clouds including scaling real-world dimensions of one or more features included in the respective raw 3D point cloud. The computer **110** may be programmed to generate a scaled 3D point cloud by scaling raw 3D map data. A scaled 3D point cloud includes information specifying a scale of the point cloud. A feature may be a lane marking **200** (FIG. **2**), a guardrail, a traffic sign **300**, and a traffic light **310**. Upon scaling a raw 3D point cloud, the coordinate system **160** of the 3D point cloud is unchanged.

In one example, the computer **110** may be programmed to receive a set of specified dimensions including a length d_1 of a lane marking **200**, respective distances d_2 between one or more sets of two road markings **200**, and dimensions d_3, d_4 of the traffic sign **300**, etc. The computer **110** may be programmed to store the set of specified dimensions in a computer **110** memory. Additionally or alternatively, the computer **110** may be programmed to determine real-world dimensions based on data received from a remote computer and/or a location of the vehicle **100**, e.g., local guidelines for dimensions or road signs, markings, etc.

In another example, with reference to FIG. **3**, the computer **110** may be programmed to receive 3D map data, e.g., an HD (High Definition) map, including dimensions of features such as traffic signs **300**, traffic lights **310**, road marking **200**, etc. The computer **110** may then scale a feature of a raw 3D map by detecting a corresponding feature in the received HD map data and determining the dimensions of the feature based on the HD map data.

As discussed above, the scaled 3D point clouds have different coordinate systems **160**, e.g., each having an origin at a point on or in the respective camera sensor **130**. Upon each point cloud’s scale being determined, a comparison of same features, e.g., a traffic sign, between data captured by different camera sensors **130** (as discussed below with reference to FIGS. **4B**, **5B**, and **6**) may be used to determine a respective pose of each camera sensor **130** relative to a reference camera, e.g., the camera sensor **130**.

The computer **110** may be programmed to determine a first transformation matrix $T_{C_2}^{C_1}$ that transforms a first coordinate system **160A** of a first scaled 3D point cloud of a first sensor **130A** to a second coordinate system **160B** of a second scaled 3D point cloud of a second sensor **130B**, as discussed below with reference to FIGS. **4A-4B** and **5A-5B**.

FIG. **4A** shows a vehicle **100** in an area **410** having lane markings **200**. FIG. **4A** shows the vehicle **100** at a first location P_1 in the area **410**. A location may be specified with GPS (global positioning system) location coordinates. The computer **110** may be programmed to identify lane markings **200** based on image data received from the camera sensor **130D**. For example, the computer **110** may detect feature

points **400**, e.g., edges of the lane marking **200**, within the field of view **140D** of the front camera sensor **130D**.

FIG. **4B** shows a top view of a scaled point cloud generated based on the detected feature points **400**. The computer **110** may be programmed to determine a scale of the point cloud, as discussed above, based on known distances such as a length d_1 of the lane markings **200**. Location coordinates of feature points **400** in the scaled point cloud illustrated by FIG. **4B** are with respect to the coordinate system **160D** of the sensor **130D**.

FIG. **5A** shows the vehicle **100** moved to a second location P_2 , e.g., 15 meters from the first location P_1 on a vehicle **100** path within a road lane. At the second location P_2 , the computer **110** may detect feature points **500**, based on the camera sensor **130D** data. At least some of the feature points **400** (FIGS. **4A-4B**), which were detected based on the data received from the sensor **130A** when the vehicle **100** was at the first location P_1 , will be included in the feature points **500** from the second location P_2 . For example, as the vehicle **100** moves from the first location P_1 to the second location P_2 , some of the feature points **400** detected by the front camera sensor **130D** may be detected by side sensors **130A**, and/or the rear sensor **130B** as the feature points **500**.

FIG. **5B** shows a top view of a second scaled 3D point cloud generated based on the feature points **500** detected within the field of view **140D**. The computer **110** may be programmed to determine the scale of the 3D point cloud, as discussed above, based on known distances such as a length d_1 of the lane markings **200**. Location coordinates of the feature points **500** are with respect to the coordinate system **160B**.

With reference to FIGS. **4B**, **5B**, and **6**, the computer **110** can be programmed to determine the first transformation matrix $T_{C_2}^{C_1}$ by “matching” one or more features **400**, **500** between the first and second 3D point clouds from the plurality of scaled 3D point clouds, thereby determining a first sensor pose R and location translation t relative to a second sensor **130**, represented as a relative transformation matrix $T_{C_2}^{C_1}$. In the present context, “matching” means recognizing feature points **400** identified in the first scaled point cloud determined based on the sensor **130A** data that correspond to feature points **500** identified in the second scaled point cloud determined based on the sensors **130** data.

As discussed above, poses R and locations t of different camera sensors **130** are different from one another. Thus, in identifying the matching feature points **400**, **500**, for example, a perspective transformation technique, e.g., Perspective-n-point (PnP) technique, etc., may be performed. A computer **110** may be programmed to identify feature points **400** of FIG. **4B** and to perform (or compute) a homography or projective transformation to match feature points **500** in FIG. **5B**. Thus, utilizing a homography technique, the computer **110** may be programmed to identify a projective transformation between the first and second feature points **400**, **500**, as discussed below.

In the present context, a “homography” or a “perspective transformation” is a line-preserving projective mapping of feature points **400**, **500** observed from two different perspectives. “Line preserving” means that if multiple points are on a same line in the first point cloud shown in FIG. **4B**, the matching feature points **500** are on a same line in the second point cloud shown in FIG. **5B**. In other words, the homography provides a mathematical relationship, e.g., the transformation matrix $T_{C_2}^{C_1}$.

The computer **110** can be programmed to determine a second transformation matrix $T_{C_2}^{C_3}$ that transforms a third coordinate system **160C** of a third scaled 3D point cloud of a third sensor **130C** to the second coordinate system **160B** of

the second scaled 3D point cloud of the second sensor **130B**, as discussed above with respect to the above example of determining the first transformation matrix $T_{C_2}^{C_1}$.

The computer **110** may be programmed, based on the first and second transformation matrices $T_{C_2}^{C_1}$, $T_{C_2}^{C_3}$, upon detecting an object **170** in a first or third camera field of view **140A**, **140C**, to determine location coordinates of the object **170** relative to a coordinate system that is defined based on the second coordinate system **160D**, and to then output the determined location coordinates of the object **170**. Additionally or alternatively, the computer **110** may be programmed to determine a transformation matrix $T_{C_2}^O$ of the object **170** relative to the coordinate system **160** of the second camera sensor **130B** including a pose R and a location t of the object **170** relative to the coordinate system **160** of the second camera sensor **130B**.

Equation (2) is based on a “dot matrix operation,” such as is known. The computer **110** may detect the object **170** based on image data received from the sensor **130A** having the coordinate system **160A**. Thus, the computer **110** may be programmed to determine the transformation matrix $T_{C_1}^O$ of the object **170** with respect to the coordinate system **160A** of the sensor **130A**. $T_{C_1}^O$ represents coordinates and pose of the detected object **170** relative to the sensor **130A** coordinate system **160A**. $T_{C_2}^O$ represents coordinates of the detected object **170** relative to the coordinate system **160D**. The computer **110** may be programmed, based on Equation (2), to determine the transformation matrix $T_{C_2}^O$ of the object **170** relative to the second coordinate system **160B** using the stored transformation matrix $T_{C_2}^{C_1}$. The computer **110** may store a transfer function $[T_{C_2}^{C_1}]$ specifying a transformation of the sensor **130A** relative to the sensor **130B**, which may be determined using the same technique discussed with respect to FIG. **6**.

$$[T_{C_2}^O]=[T_{C_2}^{C_1}][T_{C_1}^O] \quad (2)$$

Object(s) **170** may move relative to the vehicle **100** and therefore an object **170** may exit one sensor **130** field of view **140** and enter another sensor **130** field of view **140**. FIGS. **7A-7B** show the vehicle **100** and an object **170**, e.g., a second vehicle, moving relative to the vehicle **100**. With reference to FIG. **7A**, the computer **110** may be programmed to detect the object **170** within a sensor **130A** field of view **140A**.

With respect to FIG. **7B**, upon the object **170** exiting the field of view **140A** and/or entering a field of view **140D**, the computer **110** may determine the transformation matrix $[T_{C_4}^O]$ of the object **170** based on data received from the sensor **130D**. The computer **110** may be programmed, e.g., implementing Equation (3) below, to determine the coordinate $[T_{C_2}^O]$ of the object **170** based on the transformation matrices $T_{C_4}^O$, $T_{C_2}^{C_4}$. In the present context, operation (3) may be referred to as pose concatenation. A pose concatenation is a result of a matrix dot product operation on a first matrix specifying object location and pose relative to a first camera and a second transformation matrix specifying a pose and location of the first camera relative to the second coordinate system.

$$[T_{C_2}^O]=[T_{C_2}^{C_4}][T_{C_4}^O] \quad (3)$$

The computer **110** can determine the object **170** transformation matrix $[T_{C_1}^O]$ with respect to a reference field of view, e.g., the second field of view **140B**, as the object **170** is in any of the fields of view **140**, and to plan a path and/or operate the vehicle **100**, i.e., actuate a vehicle **100** actuator **120**, e.g., a steering, braking, and/or propulsion actuator **120**, based on the detected object **170**.

FIG. 8 shows another example system for determining a pose of a sensor **130** relative to a point of origin different than the sensor **130** coordinate system **160**, e.g., a reference point **150** in a vehicle **100**. The vehicle **100** may be moved to and/or placed in at a specified area **800**, e.g., in a manufacturing or service facility provided with fiducial markers **810**. Multiple fiducial markers **810** may be placed in specified locations within the area **800**.

A fiducial marker **810** is an object placed in the field of view **140** of a camera sensor **130**, for use as a point of reference or a measurement. For example, a fiducial marker **810** can include a number of ArUco fiducial marks. ArUco fiducial marks are two-dimensional (2D) patterns from a library of fiducial marks described at www.uco.es/grupos/ava/node/26, "Aplicaciones de la Vision Artificial", University of Cordoba, Spain, May 15, 2019. ArUco fiducial marks are designed to be read by machine vision software that can determine a pose in pixel coordinates for each ArUco fiducial mark included in a fiducial marker **810** by processing a 2D (two-dimensional) image of the fiducial marker **810**.

A fiducial maker **810** can be used to determine a pose of a vehicle **100** sensor **130** by displaying the fiducial marker **810** on a surface, e.g., on a ground surface, a wall, etc., in an environment, such as an area **800**, that can be occupied by a vehicle **100**. When the vehicle **100** is in the area **800** and a marker **810** is in a camera sensor **130** field of view **140**, the computer **110** may determine a 3D pose of the fiducial marker **810**, e.g., by using a machine vision technique.

The computer **110** can be programmed to receive a transformation matrix of each of a plurality of fiducial markers **810** at a plurality of locations within the area **800**. For example, the computer **110** may be programmed to receive a transformation matrix T_w^i , e.g., $i=1, 2, 3, 4$, of a marker **810** relative to a reference coordinate system **830** with an origin **840**, e.g., GPS coordinate system **830** with GPS origin point **840**. In other words, the computer **110** may receive data that specify a transformation matrix T_w^i of the markers **810** relative to the reference coordinate system **830**. Table 1 shows an example set of relative transformation matrices as discussed below with respect to Equations (4)-(8).

TABLE 1

Parameter	Description
T_w^1	world to first marker transformation matrix
T_w^2	world to second marker transformation matrix
T_w^3	world to third marker transformation matrix
T_w^4	world to fourth marker transformation matrix
T_w^{C1}	world to first camera sensor transformation matrix
T_1^{C1}	first marker to first camera sensor transformation matrix
T_2^{C2}	world to first marker transformation matrix
T_{C1}^1	first camera sensor to first marker transformation matrix
T_{C4}^{C1}	fourth camera sensor to first camera sensor transformation matrix
$T_{C_x}^{C_y}$	x^{th} camera sensor to y^{th} camera sensor transformation matrix

The computer **110** can be programmed, based on receiving image data from the sensors **130**, each image including image data including at least one of the fiducial markers **810**, to determine respective poses of respective vehicle **100** sensors **130** relative each of the fiducial markers **810**. The various sensors **130** typically have non-overlapping fields of view **140**. The computer **110** may be programmed to deter-

mine a transformation matrix T_{C1}^1 of a first marker **810** relative to the sensor **130A** coordinate system **160A**.

For example, the computer **110** may be programmed to determine the transformation matrix T_{C1}^1 of the first marker **810** relative to the sensor **130A** using a convolutional neural network (CNN). A CNN is a software program that can be implemented on a computing device that can be trained to input an image of a marker **810** and output a transformation matrix T_{C1}^1 of the marker **810** relative to the sensor **130A** coordinate system **160A**. A CNN includes a plurality of convolutional layers that extract hidden features from an input image of a vehicle **100** which are passed to a plurality of fully-connected layers that transform the hidden features into a vehicle **100** pose. A CNN can be trained to process a plurality of images of markers **810** to determine the transformation matrix T_{C1}^1 . The CNN is trained by inputting an image of a marker **810** captured by the vehicle **100** sensor **130A** and backpropagating results to be compared with the ground truth pose to determine a loss function. Training the CNN includes determining parameters for convolutional and fully-connected layers that minimize the loss function. When trained, a CNN can input an image of the markers **810** received from the vehicle **100** sensors **130** and output a transformation matrix T_{C1}^1 . Backpropagation, short for "backward propagation of errors," is an algorithm for supervised learning of artificial neural networks using gradient descent. Given an artificial neural network and an error function, the algorithm calculates the gradient of the error function with respect to the neural network's weights. Ground truth data, i.e., data deemed to provide a best representation of the real world, for training the CNN may include a set of data including (i) image data of markers **810** and (ii) respective transformation matrix relative to the sensor used for generating the training data.

The computer **110** can be programmed, as discussed with reference to Equations (4)-(8), to determine a relative transformation matrix of each of the sensors **130** with respect to a vehicle **100** coordinate system, e.g., a vehicle **100** sensor **130** coordinate system **160B**, or a vehicle **100** reference point **150**, etc. The computer **110** may be programmed, upon receiving image data including a representation of an object **170** from at least one of the sensors **130**, to determine transformation matrix of the object **170** relative to a vehicle **100** coordinate system, e.g., a coordinate system **160** at a sensor **130** location, and to actuate a vehicle **100** actuator **120** based on the detected object **170**.

Equation (4) specifies an example transformation matrix including (i) a pose matrix $R_{3 \times 1}$ which is a rotation matrix including roll, pitch, and heading of a vehicle **100**, and (ii) a location translation $T_{3 \times 1}$. The computer **110** may be programmed to implement Equation (5) to use an inverse matrix operation to calculate a transformation matrix of a first camera sensor **130** relative to a first marker **810** based on a determined transformation matrix of the first marker **810** relative to the first camera sensor **130**. The computer **110** can be programmed to implement Equation (6) to determine a transformation matrix T_w^{C1} of a first camera sensor **130** relative to the coordinate system **830** based on a transformation matrix T_w^1 and a transformation matrix T_1^{C1} .

$$T_{C1}^1 = \begin{bmatrix} R_{3 \times 1} & T_{3 \times 1} \\ 0 & 0 & 0 & 1 \end{bmatrix} \quad (4)$$

$$T_{C1}^1 = [T_1^{C1}]^{-1} \quad (5)$$

$$T_w^{C1} = [T_w^1][T_1^{C1}] \quad (6)$$

The computer **110** may be programmed to determine a transformation matrix T_{C2}^O of the object **170** relative to a

coordinate system that is defined based on the second coordinate system **160B** by performing a pose concatenation, as discussed with respect to Equation (3).

As a generalized example, the computer **110** may be programmed to implement Equation (7) to determine a transformation matrix of an x^{th} camera sensor **130** relative to a y^{th} camera sensor **130** based on (i) a real-world x^{th} marker **810** transformation matrix, and (ii) a real-world coordinate system **830** to the first camera sensor **130**. For example, Equation (8) shows an example use of Equation (7) to determine an operation to calculate the transformation matrix for the fourth camera sensor **130** relative to the first camera sensor **130**.

$$T_{C_x}^{C_y} = [T_{W}^{C_x}]^{-1} [T_{W}^{C_y}] \quad (7)$$

$$T_{C_4}^{C_1} = [T_{W}^{C_4}]^{-1} [T_{W}^{C_1}] \quad (8)$$

FIG. 9 is a flowchart of an example process **900** for performing extrinsic calibration of vehicle **100** sensors **130** and operating the vehicle **100** using 3D point cloud data. The computer **110** may be programmed to execute blocks of the process **900**.

The process **900** begins in a block **910**, in which the computer **110** receives image data from the vehicle **100** camera sensors **130** with non-overlapping fields of view **140**.

Next, in a block **920**, the computer **110** generates raw 3D point clouds from respective sensors **130**. The computer **110** may be programmed to utilize the Monocular VO technique, etc., to generate the raw 3D point clouds based on the received image data from the vehicle **100** sensors **130**.

Next, in a block **930**, the computer **110** scales each of the raw 3D point clouds, e.g., based on HD map data and/or specified dimensions d_1 , d_2 of features, as discussed with respect to FIGS. 2-3.

Next, in a block **940**, the computer **110** determines the transformation matrix $T_{C_1}^{C_2}$ of a first sensor **130** relative to second sensor **130**. With reference to FIGS. 4A-4B and 5A-5B, the computer **110** may be programmed to identify feature points **400** based on the first scaled point cloud and the feature point **500** based on the second scaled 3D point cloud, and to determine the transformation matrix $T_{C_2}^{C_1}$ based on the identified matching feature points **400**, **500**.

Next, in a decision block **950**, the computer **110** determines whether an object **170** is detected in the first sensor **130** field of view **140**. If the computer **110** detects an object **170** in the field of view **140** of the first sensor **130**, then the process **900** proceeds to a block **960**; otherwise the process **900** returns to the decision block **950**, or alternatively returns to the block **910**, although not shown in FIG. 9.

In the block **960**, the computer **110** determines the coordinates of the object **170** relative to a second coordinate system, e.g., the second sensor **130D** coordinate system **160B**, or a second coordinate system with an origin at a vehicle **100** reference point **150**. As discussed with respect to Equation (3), the computer **110** may be programmed to determine a transformation matrix, including pose and coordinates, of the object relative to the second camera sensor **130D**.

Following the block **960**, in a block **970**, the computer **110** actuates a vehicle **100** actuator **120** based on the identified coordinates t and/or pose R of the object **170** relative to the second coordinate system of the vehicle **100**, e.g., with an origin at the second sensor **130D**. Following the block **970**, the process **900** ends, or alternatively returns to the decision block **950**, although not shown in FIG. 9.

FIG. 10 illustrates a flowchart of a process **1000** for performing extrinsic calibration of vehicle **100** sensors **130** using fiducial markers **810** located in the fields of view **140** of vehicle **100** sensors **130**. The computer **110** may be programmed to execute blocks of the process **1000**.

The process **1000** begins in a block **1010**, in which the computer **110** receives transformation matrix, T_{W}^1 , of fiducial markers **810** (Table 1).

Next, in a block **1020**, the computer **110** determines whether the vehicle **100** is located at a specified location **800** (such as described above with respect to FIG. 8). The computer **110** may be programmed to determine that the vehicle **100** is at the specified location **800** based on data received from a remote computer, a vehicle **100** sensor **130**, etc. If the computer **110** determines that the vehicle **100** is at the specified location **800**, then the process **1000** proceeds to a block **1030**; otherwise the process **1000** returns to the block **1020**, or alternatively returns to the block **1010**, although not shown in FIG. 10.

In the block **1030**, the computer **110** receives image data from the vehicle **100** camera sensors **130** with non-overlapping fields of view **140**. The received image data from each of the sensors **130** include image data of at least a fiducial marker **810** located within the field of view **140** of the respective sensor **130**.

Next, in a block **1040**, the computer **110** determines respective transformation matrices of the vehicle **100** relative to each of fiducial markers **810**, e.g., the transformation matrix $T_1^{C_1}$ of the first camera sensor **130** relative to a first marker **180**.

Next, in a block **1050**, the computer **110** determines a relative transformation matrix of each of vehicle sensors with respect to vehicle **100** coordinate system. For example, the computer **110** may be programmed to implement Equations (4)-(8) to determine a transformation matrix $T_{C_4}^{C_1}$ of x^{th} camera sensor **130** to y^{th} camera sensor **130**.

Next, in a decision block **1060**, the computer **110** determines whether an object **170** is detected in first sensor **130** data (as discussed concerning FIG. 8). If the computer **110** determines that the object **170** is detected in the field of view **140** of the first sensor **130**, the process **1000** proceeds to a block **1070**; otherwise returns to the decision block **1060**, or alternatively ends, although not shown in FIG. 10.

In the block **1070**, the computer **110** determines coordinates t and/or pose R of object **170** relative to vehicle **100** coordinate system. The computer **110** may be programmed, based on Equation (3), to determine the transformation matrix $T_{C_1}^O$ of the object **170** within first sensor **130** field of view relative to the coordinate system **160D** of the second sensor **130**.

Next, in a block **1080**, the computer **110** actuates a vehicle **100** actuator **120** based on the determined transformation matrix $T_{C_2}^O$. The computer **110** may be programmed to actuate a brake, steering, and/or propulsion actuator **120** based on the detected object **170**.

Following the block **1080**, the process **1000** ends, or alternatively returns to the block **1010**, although not shown in FIG. 10.

As used herein, the adverb “substantially” means that a shape, structure, measurement, quantity, time, etc. may deviate from an exact described geometry, distance, measurement, quantity, time, etc., because of imperfections in materials, machining, manufacturing, transmission of data, computational speed, etc.

“Based on” encompasses “based wholly or partly on.” If, herein, a first thing is described and/or claimed as being “based on” the second thing, then the first thing is derived

or calculated from the second thing, and/or output from an algorithm, process, or program function that accepts some or all of the second thing as input and outputs some or all of the first thing.

Computing devices as discussed herein generally each include instructions executable by one or more computing devices such as those identified above, and for carrying out blocks or steps of processes described above. Computer-executable instructions may be compiled or interpreted from computer programs created using a variety of programming languages and/or technologies, including, without limitation, and either alone or in combination, Java™, C, C++, Visual Basic, Java Script, Perl, HTML, etc. In general, a processor (e.g., a microprocessor) receives instructions, e.g., from a memory, a computer-readable medium, etc., and executes these instructions, thereby performing one or more processes, including one or more of the processes described herein. Such instructions and other data may be stored and transmitted using a variety of computer-readable media. A file in the computing device is generally a collection of data stored on a computer readable medium, such as a storage medium, a random-access memory, etc.

A computer-readable medium includes any medium that participates in providing data (e.g., instructions), which may be read by a computer. Such a medium may take many forms, including, but not limited to, non-volatile media, volatile media, etc. Non-volatile media include, for example, optical or magnetic disks and other persistent memory. Volatile media include dynamic random-access memory (DRAM), which typically constitutes a main memory. Common forms of computer-readable media include, for example, a floppy disk, a flexible disk, hard disk, magnetic tape, any other magnetic medium, a CD-ROM, DVD, any other optical medium, punch cards, paper tape, any other physical medium with patterns of holes, a RAM, a PROM, an EPROM, a FLASH-EEPROM, any other memory chip or cartridge, or any other medium from which a computer can read.

With regard to the media, processes, systems, methods, etc. described herein, it should be understood that, although the steps of such processes, etc. have been described as occurring according to a certain ordered sequence, such processes could be practiced with the described steps performed in an order other than the order described herein. It further should be understood that certain steps could be performed simultaneously, that other steps could be added, or that certain steps described herein could be omitted. In other words, the descriptions of systems and/or processes herein are provided for the purpose of illustrating certain embodiments, and should in no way be construed so as to limit the disclosed subject matter.

Accordingly, it is to be understood that the present disclosure, including the above description and the accompanying figures and below claims, is intended to be illustrative and not restrictive. Many embodiments and applications other than the examples provided would be apparent to those of skill in the art upon reading the above description. The scope of the invention should be determined, not with reference to the above description, but should instead be determined with reference to claims appended hereto and/or included in a non-provisional patent application based hereon, along with the full scope of equivalents to which such claims are entitled. It is anticipated and intended that future developments will occur in the arts discussed herein, and that the disclosed systems and methods will be incor-

porated into such future embodiments. In sum, it should be understood that the disclosed subject matter is capable of modification and variation.

All terms used in the claims are intended to be given their plain and ordinary meanings as understood by those skilled in the art unless an explicit indication to the contrary is made herein. In particular, use of the singular articles such as “a,” “the,” “said,” etc. should be read to recite one or more of the indicated elements unless a claim recites an explicit limitation to the contrary.

What is claimed is:

1. A computing device, comprising a processor and a memory, the memory storing instructions executable by the processor to:
 - generate a plurality of raw 3D point clouds from respective sensors having non-overlapping fields of view;
 - scale each of the raw point clouds including scaling real-world dimensions of one or more features included in the respective raw 3D point cloud;
 - determine a first transformation matrix that transforms a first coordinate system of a first scaled 3D point cloud of a first sensor to a second coordinate system of a second scaled 3D point cloud of a second sensor;
 - determine a second transformation matrix that transforms a third coordinate system of a third scaled 3D point cloud of a third sensor to the second coordinate system of the second scaled 3D point cloud of the second sensor;
 - based on the first and second transformation matrices, upon detecting an object in a first or third camera field of view, determine location coordinates of the object relative to a coordinate system that is defined based on the second coordinate system; and
 - output the determined location coordinates of the object.
2. The computing device of claim 1, wherein the instructions further include instructions to generate the raw 3D point clouds by applying monocular visual odometry technique to image data received from the respective sensor.
3. The computing device of claim 1, wherein each of the plurality of 3D point clouds is generated based on data received from one of a plurality of sensors.
4. The computing device of claim 1, wherein the one or more features include at least one of a lane marking, a guardrail, a traffic sign, and a traffic light, and wherein the real-world dimensions are determined based on at least one of (i) received HD map data or (ii) a set of specified dimensions including distances between two or more road markings, and dimensions of the traffic sign.
5. The computing device of claim 1, wherein the instructions further include instructions to determine the first transformation matrix by matching one or more features between the first and second 3D point clouds from the plurality of scaled 3D point clouds, thereby determining a first sensor pose relative to a second sensor pose; the second coordinate system defined based on the second sensor pose.
6. The computing device of claim 1, wherein the instructions further include instructions to determine the second transformation matrix by matching one or more features between the third scaled 3D point cloud and the second scaled 3D point clouds from the plurality of raw 3D point clouds, thereby generating a third sensor pose relative to the second sensor pose; the second coordinate system defined based on the second sensor pose.
7. A computing device, comprising a processor and a memory, the memory storing instructions executable by the processor to:

17

receive a transformation matrix of each of a plurality of stationary fiducial markers at a plurality of locations; based on receiving image data from each of a plurality of sensors, each image including image data including at least one of the fiducial markers, determine respective transformation matrices of a vehicle relative each of the fiducial markers, wherein each of the sensors is included on the vehicle and wherein the sensors have non-overlapping fields of view; determine a relative transformation matrix of each of the sensors with respect to a vehicle coordinate system having an origin at a vehicle reference point; upon receiving the image data including an object from at least one of the sensors, determine transformation matrix of the object relative to the vehicle coordinate system; and actuate a vehicle actuator based on the object.

8. The computing device of claim 7, wherein the instructions further include instructions to determine the relative transformation matrix of each of the sensors with respect to the vehicle coordinate system by performing a pose concatenation.

9. The computing device of claim 7, wherein the received transformation matrix of each of a plurality of stationary fiducial markers at a plurality of locations are defined relative to a second coordinate system outside the vehicle, and each pose includes roll, pitch, yaw, lateral, longitudinal, and elevation coordinates.

10. The computing device of claim 7, wherein each of the fiducial markers is an Aruco marker.

11. The computing device of claim 7, wherein the instructions further include instructions to determine transformation matrix of the object relative to a coordinate system that is defined based on a second coordinate system by performing a pose concatenation, wherein the pose concatenation is a result of a matrix dot product operation on a first matrix specifying object coordinates relative to a first camera and a second transformation matrix specifying a pose and coordinates of the first camera relative to the second coordinate system.

12. A method, comprising:
 generating a plurality of raw 3D point clouds from respective sensors having non-overlapping fields of view;
 scaling each of the raw point clouds including scaling real-world dimensions of one or more features included in the respective raw 3D point cloud;

18

determining a first transformation matrix that transforms a first coordinate system of a first scaled 3D point cloud of a first sensor to a second coordinate system of a second scaled 3D point cloud of a second sensor;

determining a second transformation matrix that transforms a third coordinate system of a third scaled 3D point cloud of a third sensor to the second coordinate system of the second scaled 3D point cloud of the second sensor;

based on the first and second transformation matrices, upon detecting an object in a first or third camera field of view, determining location coordinates of the object relative to a coordinate system that is defined based on the second coordinate system; and

outputting the determined location coordinates of the object.

13. The method of claim 12, further comprising generating the raw 3D point clouds by applying monocular visual odometry technique to image data received from the respective sensor, wherein each of the plurality of 3D point clouds is generated based on data received from one of a plurality of sensors.

14. The method of claim 12, wherein the one or more features include at least one of a lane marking, a guardrail, a traffic sign, and a traffic light, and wherein the real-world dimensions are determined based on at least one of (i) received HD map data or (ii) a set of specified dimensions including distances between two or more road markings, and dimensions of the traffic sign.

15. The method of claim 12, further comprising determining the first transformation matrix by matching one or more features between the first and second 3D point clouds from the plurality of scaled 3D point clouds, thereby determining a first sensor pose relative to a second sensor pose; the second coordinate system defined based on the second sensor pose.

16. The method of claim 12, further comprising determining the second transformation matrix by matching one or more features between the third scaled 3D point cloud and the second scaled 3D point clouds from the plurality of raw 3D point clouds, thereby generating a third sensor pose relative to the second sensor pose; the second coordinate system defined based on the second sensor pose.

* * * * *