

(19) **DANMARK**

(10) **DK/EP 3443609 T3**



(12) **Oversættelse af
europæisk patentskrift**

Patent- og
Varemærkestyrelsen

-
- (51) Int.Cl.: **H 01 M 8/0273 (2016.01)** **H 01 M 8/18 (2006.01)** **H 01 M 8/2404 (2016.01)**
H 01 M 8/242 (2016.01) **H 01 M 8/2455 (2016.01)**
- (45) Oversættelsen bekendtgjort den: **2024-10-07**
- (80) Dato for Den Europæiske Patentmyndigheds bekendtgørelse om meddelelse af patentet: **2024-07-31**
- (86) Europæisk ansøgning nr.: **16898130.6**
- (86) Europæisk indleveringsdag: **2016-04-27**
- (87) Den europæiske ansøgnings publiceringsdag: **2019-02-20**
- (86) International ansøgning nr.: **US2016029599**
- (87) Internationalt publikationsnr.: **WO2017176294**
- (30) Prioritet: **2016-04-07 US 201615093598**
- (84) Designerede stater: **AL AT BE BG CH CY CZ DE DK EE ES FI FR GB GR HR HU IE IS IT LI LT LU LV MC MK MT NL NO PL PT RO RS SE SI SK SM TR**
- (73) Patenthaver: **Lockheed Martin Energy, LLC, 6801 Rockledge Drive, Bethesda, MD 20817-1877, USA**
- (72) Opfinder: **WARRINGTON, Curtis, 3 Ethan Allen Drive, Acton, Massachusetts 01720, USA**
MADDEN, Thomas H., 2767 Hebron Avenue, Glastonbury, Connecticut 06033, USA
PURANAM, Srivatsava, 15 Fayette Street, Apartment 3, Cambridge, Massachusetts 02139, USA
- (74) Fuldmægtig i Danmark: **Zacco Denmark A/S, Arne Jacobsens Allé 15, 2300 København S, Danmark**
- (54) Benævnelse: **FREMSTILLINGSPROCESSER MED HØJ KAPACITET TIL FREMSTILLING AF ELEKTROKEMISKE ENHEDSCELLER OG ELEKTROKEMISKE ENHEDSCELLER FREMSTILLET DERMED**
- (56) Fremdragne publikationer:
WO-A1-2008/073679
CN-A- 103 579 658
JP-A- 2015 215 948
JP-A- H 087 913
KR-A- 20150 007 750
US-A- 4 532 193
US-A- 4 902 589
US-A1- 2004 241 525
US-A1- 2006 068 265
US-A1- 2014 051 007
US-A1- 2014 349 147

DESCRIPTION

Description

FIELD

[0001] The present disclosure generally relates to electrochemical unit cells and, more specifically, to high-throughput manufacturing processes for electrochemical unit cells for use in flow batteries and other electrochemical systems.

BACKGROUND

[0002] Electrochemical energy storage systems, such as batteries, supercapacitors and the like, have been widely proposed for large-scale energy storage applications. Various battery designs, including flow batteries, have been considered for this purpose. Compared to other types of electrochemical energy storage systems, flow batteries can be advantageous, particularly for large-scale applications, due to their ability to decouple the parameters of power density and energy density from one another.

[0003] Flow batteries generally include negative and positive active materials in corresponding electrolyte solutions, which are flowed separately across opposing sides of a membrane or separator in an electrochemical cell containing negative and positive electrodes. The flow battery is charged or discharged through electrochemical reactions of the active materials that occur inside the two half-cells. As used herein, the terms "active material," "electroactive material," "redox-active material" or variants thereof will synonymously refer to materials that undergo a change in oxidation state during operation of a flow battery or like electrochemical energy storage system (*i.e.*, during charging or discharging). A full electrochemical cell contains two half-cells (*i.e.*, a positive half-cell and a negative half-cell) that are separated by the separator material.

[0004] In order to increase the amount of energy that can be stored and released by a flow battery, a plurality of individual electrochemical cells can be placed in electrical communication with one another. Placing the individual electrochemical cells in electrical communication with one another typically involves positioning the individual electrochemical cells in a "cell stack" or "electrochemical stack" with a bipolar plate establishing electrical communication between adjacent electrochemical cells.

[0005] Design and fabrication of individual electrochemical cells typically involves the mating of

various "hard goods" and "soft goods" together with one another. Soft goods can include the separator material, electrodes, and seals used to contain the electrolyte solution in a desired area within the electrochemical cell. Hard goods can include the bipolar plate and any framing materials used to contain the soft goods. Conventional manufacturing processes for electrochemical cells oftentimes mold and/or machine the hard goods for the individual cells, and cell assembly is then completed by positioning the soft goods manually or with semi-automated pick-and-place processes. Such manual and semi-automated batch processes for assembling electrochemical cells represent a rate-limiting manufacturing step that is largely incapable of producing high throughput. Even the molding and machining processes for the hard goods can become problematic if construction of a significantly large number of individual electrochemical cells is needed. Moreover, batch manufacturing processes of the foregoing types can be highly susceptible to producing faulty cells as a result of operator error. Accordingly, manufacturing processes for producing electrochemical cells and cells stacks remain laborious, time-consuming, and expensive.

[0006] In view of the foregoing, electrochemical cell designs that are compatible with high-throughput manufacturing processes would be highly desirable in the art. The present disclosure satisfies the foregoing need and provides related advantages as well.

[0007] JP H08 7913 A discloses an all-vanadium redox battery comprising a positive electrode and a negative electrode disposed with a diaphragm interposed therebetween, wherein a plurality of cells having a positive electrode chamber and a negative electrode chamber, which are composed of bipolar plates sandwiching the electrodes from the outside, are alternately laminated with the bipolar plate interposed therebetween.

[0008] CN 103579658 A relates to a flow battery pile which comprises single flow batteries, an anode-end pressure plate, a cathode-end pressure plate and fasteners, wherein a plurality of single flow batteries are vertically overlapped and are fixedly arranged between the anode-end pressure plate and the cathode-end pressure plate through the fasteners to form a pile. Each single flow battery comprises bipolar plates and a membrane electrode assembly clamped between the bipolar plates, and a fluid in and out hole is formed in the bipolar plates. The bipolar plates comprise a plate frame and an electrode plate which is arranged in an inner frame of the plate frame. The four angles of the pile are respectively provided with an electrolyte in and out main pipe, and each electrolyte in and out main pipe is connected with the fluid in and out hole of each single flow battery through an electrolyte in and out branch pipe. Electrolyte flows into the pile to participate in an electrochemical reaction through the electrolyte in and out main pipes and the electrolyte in and out branch pipes outside the pile.

[0009] US 2004/241525 A1 discloses a method of continuously producing a multiple layer web of fuel cell material, comprising laminating first and second webs, each comprising bonding material and having spaced apart windows, to first and second surfaces of a web comprising a fuel cell membrane, first and second active regions of the membrane web positioned within the respective bonding material windows; laminating third and fourth webs, each comprising a gasket material and having spaced apart windows, respectively to the bonding material

disposed on the first and second surfaces the membrane web, the windows of the bonding material aligning with the respective windows of the gasket material so that at least some of the bonding material extends within the respective gasket material windows; and laminating fluid transport layer (FTL) material portions cut from fifth and sixth webs comprising FTL material to the respective first and second active regions of the membrane web, the FTL material portions positioned within respective gasket material windows and contacting the bonding material extending within the respective gasket material windows.

[0010] WO 2008/073679 A1 discloses fabrication methods for making a gas diffusion layer incorporating a gasket (GIG) fuel cell subassemblies via roll-to-roll processes. A material processable by one or both of heat and pressure having spaced apart apertures is transported to a bonding station. A first gasket layer having gas diffusion layers arranged in relation to spaced apart apertures of a first gasket layer is transported to the bonding station. The heat/pressure processable material is aligned with the first gasket layer and the gas diffusion layers. At the bonding station, the heat/pressure processable material is bonded to the first gasket layer and the gas diffusion layers. After bonding, the heat/pressure processable material forms a second gasket layer that attaches the gas diffusion layers to the first gasket layer.

SUMMARY

[0011] The present invention relates to an electrochemical unit cell according to claim 1. The present invention further relates to an electrochemical stack according to claim 5 and a method for forming an electrochemical unit cell according to claim 7. Preferred embodiments are set forth in the dependent claims. BRIEF DESCRIPTION OF THE DRAWINGS

[0012] For a more complete understanding of the present disclosure, and the advantages thereof, reference is now made to the following descriptions to be taken in conjunction with the accompanying drawings describing specific embodiments of the disclosure, wherein:

FIGURE 1 shows a schematic of an illustrative flow battery containing a single electrochemical unit cell;

FIGURE 2 shows an exploded view of an illustrative electrochemical unit cell configuration, in which the various cell components are spaced apart from one another to show detail;

FIGURE 3A shows a more detailed view from the cathode side of the electrochemical unit cell of FIGURE 2;

FIGURE 3B shows a more detailed view from the anode side of the electrochemical unit cell of FIGURE 2;

FIGURE 4 shows a section view of the electrochemical unit cell of FIGURE 2 with the various cell components fully abutted together with one another;

FIGURE 5 shows an exploded view of another illustrative electrochemical unit cell configuration, in which the various cell components are spaced apart from one another to show detail;

FIGURE 6 (not according to the present invention) shows a section view of the electrochemical unit cell of FIGURE 5 with the various cell components fully abutted together with one another;

FIGURE 7 shows a schematic of an illustrative electrochemical stack in which bipolar plates from adjacent electrochemical cells are abutted against one another;

FIGURE 8 shows a schematic of an illustrative electrochemical stack in which adjacent electrochemical cells share a common bipolar plate;

FIGURE 9 shows a schematic of an illustrative production line that can combine the soft goods of an electrochemical unit cell in a continuous fashion;

FIGURES 10A and 10B show illustrative top and side-view schematics of the soft goods assembly produced by the production line of FIGURE 9;

FIGURE 10C shows a simplified rendition of FIGURE 10B with backing layers being omitted for clarity;

FIGURE 11 shows a schematic of an illustrative production line that can combine the hard goods of an electrochemical unit cell in a continuous fashion;

FIGURES 12A and 12B show illustrative top and side-view schematics of the hard goods assembly fabricated by the production line of FIGURE 11;

FIGURE 12C shows a simplified rendition of the configuration of FIGURE 12B with the pressure-sensitive adhesive layers omitted for clarity;

FIGURE 13 shows a schematic of an illustrative 3-cell electrochemical stack in which the soft goods assembly of FIGURES 10A-10C and the hard goods assembly of FIGURES 12A-12C are stacked in an alternating manner; and

FIGURE 14 shows a schematic of an illustrative production line that can produce an electrochemical unit cell in a continuous fashion.

DETAILED DESCRIPTION

[0013] The present disclosure is directed, in part, to electrochemical unit cells and electrochemical cell stacks that are compatible with high-throughput manufacturing processes. The present disclosure is also directed, in part, to manufacturing processes for electrochemical unit cells and electrochemical cell stacks in which materials are supplied to a production line from rolled sources. The present disclosure is also directed, in part, to production line systems

for manufacturing electrochemical unit cells and electrochemical cell stacks.

[0014] The present disclosure may be understood more readily by reference to the following description taken in connection with the accompanying figures and examples, all of which form a part of this disclosure. It is to be understood that this disclosure is not limited to the specific products, methods, conditions or parameters described and/or shown herein. Further, the terminology used herein is for purposes of describing particular embodiments by way of example only and is not intended to be limiting unless otherwise specified. Similarly, unless specifically stated otherwise, any description herein directed to a composition is intended to refer to both solid and liquid versions of the composition, including solutions and electrolytes containing the composition, and electrochemical cells, flow batteries, and other energy storage systems containing such solutions and electrolytes. Further, it is to be recognized that where the disclosure herein describes an electrochemical cell, flow battery, or other energy storage system, it is to be appreciated that methods for operating the electrochemical cell, flow battery, or other energy storage system are also implicitly described.

[0015] It is also to be appreciated that certain features of the present disclosure may be described herein in the context of separate embodiments for clarity purposes, but may also be provided in combination with one another in a single embodiment. That is, unless obviously incompatible or specifically excluded, each individual embodiment is deemed to be combinable with any other embodiment(s) and the combination is considered to represent another distinct embodiment. Conversely, various features of the present disclosure that are described in the context of a single embodiment for brevity's sake may also be provided separately or in any subcombination. Finally, while a particular embodiment may be described as part of a series of steps or part of a more general structure, each step or sub-structure may also be considered an independent embodiment in itself.

[0016] Unless stated otherwise, it is to be understood that each individual element in a list and every combination of individual elements in that list is to be interpreted as a distinct embodiment. For example, a list of embodiments presented as "A, B, or C" is to be interpreted as including the embodiments "A," "B," "C," "A or B," "A or C," "B or C," or "A, B, or C."

[0017] In the present disclosure, the singular forms of the articles "a," "an," and "the" also include the corresponding plural references, and reference to a particular numerical value includes at least that particular value, unless the context clearly indicates otherwise. Thus, for example, reference to "a material" is a reference to at least one of such materials and equivalents thereof.

[0018] In general, use of the term "about" indicates approximations that can vary depending on the desired properties sought to be obtained by the disclosed subject matter and is to be interpreted in a context-dependent manner based on functionality. Accordingly, one having ordinary skill in the art will be able to interpret a degree of variance on a case-by-case basis. In some instances, the number of significant figures used when expressing a particular value may be a representative technique of determining the variance permitted by the term "about." In

other cases, the gradations in a series of values may be used to determine the range of variance permitted by the term "about." Further, all ranges in the present disclosure are inclusive and combinable, and references to values stated in ranges include every value within that range.

[0019] As discussed above, energy storage systems that are operable on a large scale while maintaining high efficiency values can be extremely desirable. Flow batteries have generated significant interest in this regard, but no flow battery technologies that are truly commercially viable have yet been developed. The general lack of high-throughput manufacturing processes for flow batteries, particularly the individual electrochemical unit cells of flow batteries and electrochemical stacks of such electrochemical unit cells, is one issue that has hampered their successful commercial development. Exemplary description of illustrative flow batteries, their use, and operating characteristics is provided hereinbelow.

[0020] The present inventors developed various designs for electrochemical unit cells that are readily compatible with high-throughput manufacturing techniques. The individual electrochemical unit cells of the present disclosure can also be combined with one another in electrochemical stacks to increase the amount of energy stored and released by a flow battery. More specifically, the inventors developed electrochemical cell designs that can be manufactured entirely or substantially with materials supplied from rolled sources to a production line, thereby allowing mass production of individual electrochemical unit cells to take place. Before further discussing the electrochemical unit cell designs and the manufacturing processes for their fabrication, a brief overview of flow batteries and their various components will be provided first.

[0021] FIGURE 1 shows a schematic of an illustrative flow battery containing a single electrochemical unit cell. Unlike typical battery technologies (e.g., Li-ion, Ni-metal hydride, lead-acid, and the like), where active materials and other components are housed in a single assembly, flow batteries transport (e.g., via pumping) redox-active energy storage materials from storage tanks through an electrochemical stack. This design feature decouples the electrical energy storage system power from the energy storage capacity, thereby allowing for considerable design flexibility and cost optimization.

[0022] As shown in FIGURE 1, flow battery system 1 includes an electrochemical cell that features separator 20 (e.g., a membrane) that separates the two electrodes 10 and 10' of the electrochemical cell. Electrodes 10 and 10' are formed from a suitably conductive material, such as a metal, carbon, graphite, and the like. Tank 50 contains first active material 30, which is capable of being cycled between an oxidized state and a reduced state.

[0023] Pump 60 affects transport of first active material 30 from tank 50 to the electrochemical cell. The flow battery also suitably includes second tank 50' that contains second active material 40. Second active material 40 can be the same material as active material 30, or it can be different. Second pump 60' can affect transport of second active material 40 to the electrochemical cell. Pumps can also be used to affect transport of the active materials from

the electrochemical cell back to tanks 50 and 50' (not shown in FIGURE 1). Other methods of affecting fluid transport, such as siphons, for example, can also suitably transport first and second active materials 30 and 40 into and out of the electrochemical cell. Also shown in FIGURE 1 is power source or load 70, which completes the circuit of the electrochemical cell and allows a user to collect or store electricity during its operation.

[0024] It should be understood that FIGURE 1 depicts a specific, non-limiting configuration of a flow battery. Accordingly, flow batteries and electrochemical unit cells can differ in various aspects relative to the configuration of FIGURE 1. As one example, a flow battery system can include one or more active materials that are solids, gases, and/or gases dissolved in liquids. Active materials can be stored in a tank, in a vessel open to the atmosphere, or simply vented to the atmosphere.

[0025] As used herein, the terms "separator" and "membrane" will refer to an ionically conductive and electrically insulating material disposed between the positive and negative electrodes of an electrochemical cell (*i.e.*, between the negative half-cell and the positive half-cell). The separator can be a porous membrane in some embodiments and/or an ionomer membrane in other various embodiments. In some embodiments, the separator can be formed from an ionically conductive polymer.

[0026] Polymer membranes can be anion- or cation-conducting electrolytes. Where described as an "ionomer," the term refers to polymer membrane containing both electrically neutral repeating units and ionized repeating units, where the ionized repeating units are pendant and covalently bonded to the polymer backbone. In general, the fraction of ionized repeating units can range from about 1 mole percent to about 90 mole percent. Ionized repeating units in an ionomer can include anionic functional groups such as sulfonate, carboxylate, and the like. These functional groups can be charge balanced by mono-, di-, or higher-valent cations, such as alkali or alkaline earth metals. Ionomers can also include polymer compositions containing attached or embedded quaternary ammonium, sulfonium, phosphazanium, and guanidinium residues or salts. Suitable examples will be familiar to one having ordinary skill in the art.

[0027] In some embodiments, polymers useful as a separator can include highly fluorinated or perfluorinated polymer backbones. Certain polymers useful in the present disclosure can include copolymers of tetrafluoroethylene and one or more fluorinated, acid-functional comonomers, which are commercially available as NAFION[™] perfluorinated polymer electrolytes from DuPont. Other useful perfluorinated polymers can include copolymers of tetrafluoroethylene and $\text{FSO}_2\text{-CF}_2\text{CF}_2\text{CF}_2\text{CF}_2\text{-O-CF=CF}_2$, FLEMION[™] and SELEMION[™].

[0028] Additionally, substantially non-fluorinated membranes that are modified with sulfonic acid groups (or cation exchanged sulfonate groups) can also be used. Such membranes can include those with substantially aromatic backbones such as, for example, polystyrene, polyphenylene, biphenyl sulfone (BPSH), or thermoplastics such as polyetherketones and polyethersulfones.

[0029] Battery-separator style porous membranes, can also be used as the separator. Because they contain no inherent ionic conduction capabilities, such membranes are typically impregnated with additives in order to function. These membranes typically contain a mixture of a polymer and inorganic filler, and open porosity. Suitable polymers can include, for example, high density polyethylene, polypropylene, polyvinylidene difluoride (PVDF), or polytetrafluoroethylene (PTFE). Suitable inorganic fillers can include silicon carbide matrix material, titanium dioxide, silicon dioxide, zinc phosphide, and ceria.

[0030] Separators can also be formed from polyesters, polyetherketones, poly(vinyl chloride), vinyl polymers, and substituted vinyl polymers. These can be used alone or in combination with any previously described polymer.

[0031] Porous separators are non-conductive membranes which allow charge transfer between two electrodes via open channels filled with electrolyte. The pore size distribution of a porous separator can be sufficient to substantially prevent the crossover of active materials between the two electrolyte solutions. Suitable porous membranes can have an average pore size distribution of between about 0.001 nm and 20 micrometers, more typically between about 0.001 nm and 100 nm. The size distribution of the pores in the porous membrane can be substantial. In other words, a porous membrane can contain a first plurality of pores with a very small diameter (approximately less than 1 nm) and a second plurality of pores with a very large diameter (approximately greater than 10 micrometers). The larger pore sizes can lead to a higher amount of active material crossover. The ability for a porous membrane to substantially prevent the crossover of active materials can depend on the relative difference in size between the average pore size and the active material. For example, when the active material is a metal center in a coordination complex, the average diameter of the coordination complex can be about 50% greater than the average pore size of the porous membrane. On the other hand, if a porous membrane has substantially uniform pore sizes, the average diameter of the coordination complex can be about 20% larger than the average pore size of the porous membrane. Likewise, the average diameter of a coordination complex is increased when it is further coordinated with at least one water molecule. The diameter of a coordination complex of at least one water molecule is generally considered to be the hydrodynamic diameter. In such embodiments, the hydrodynamic diameter is generally at least about 35% greater than the average pore size. When the average pore size is substantially uniform, the hydrodynamic radius can be about 10% greater than the average pore size.

[0032] In some embodiments, the separator can also include reinforcement materials for greater stability. Suitable reinforcement materials can include, for example, nylon, cotton, polyesters, crystalline silica, crystalline titania, amorphous silica, amorphous titania, rubber, asbestos, wood or any combination thereof. Other suitable reinforcement materials can be envisioned by one having ordinary skill in the art.

[0033] Separators within can have a membrane thickness of less than about 500 micrometers, or less than about 300 micrometers, or less than about 250 micrometers, or less than about 200 micrometers, or less than about 100 micrometers, or less than about 75 micrometers, or

less than about 50 micrometers, or less than about 30 micrometers, or less than about 25 micrometers, or less than about 20 micrometers, or less than about 15 micrometers, or less than about 10 micrometers. Suitable separators can include those in which a flow battery is capable of operating with a current efficiency of greater than about 85% with a current density of 100 mA/cm² when the separator has a thickness of 100 micrometers. In further embodiments, the flow battery is capable of operating at a current efficiency of greater than 99.5% when the separator has a thickness of less than about 50 micrometers, a current efficiency of greater than 99% when the separator has a thickness of less than about 25 micrometers, and a current efficiency of greater than 98% when the separator has a thickness of less than about 10 micrometers. Accordingly, suitable separators include those in which a flow battery is capable of operating at a voltage efficiency of greater than 60% with a current density of 100 mA/cm². In further embodiments, suitable separators can include those in which a flow battery is capable of operating at a voltage efficiency of greater than 70%, greater than 80% or even greater than 90%.

[0034] Flow batteries can also include an external electrical circuit in electrical communication with the first and second electrodes. The circuit can charge and discharge the flow battery during operation. Reference to the sign of the net ionic charge of the first, second, or both active materials relates to the sign of the net ionic charge in both oxidized and reduced forms of the redox-active materials under the operating conditions of a flow battery. Further exemplary embodiments of a flow battery provide that (a) the first active material has an associated net positive or negative charge and is capable of providing an oxidized or reduced form over an electric potential in a range of the negative operating potential of the system, such that the resulting oxidized or reduced form of the first active material has the same charge sign (positive or negative) as the first active material and the ionomer membrane also has a net ionic charge of the same sign; and (b) the second active material has an associated net positive or negative charge and is capable of providing an oxidized or reduced form over an electric potential in a range of the positive operating potential of the system, such that the resulting oxidized or reduced form of the second active material has the same charge sign (positive or negative sign) as the second active material and the ionomer membrane also has a net ionic charge of the same sign; or both (a) and (b). The matching charges of the first and/or second active materials and the ionomer membrane can provide a high selectivity. More specifically, charge matching can provide less than about 3%, less than about 2%, less than about 1%, less than about 0.5%, less than about 0.2%, or less than about 0.1% of the molar flux of ions passing through the ionomer membrane as being attributable to the first or second active material. The term "molar flux of ions" will refer to the amount of ions passing through the ionomer membrane, balancing the charge associated with the flow of external electricity/electrons.

[0035] Particular electrode materials can include carbon and various metals. Non-conductive plastic materials can also constitute a portion of an electrode material. In some embodiments, electrodes can have a catalyst deposited thereon. Other types of layers can also be present on the electrode materials. Functions of the optional layers can include, for example, aiding cell assembly, improving contact resistance, and/or providing protection for the separator.

[0036] Having now described and depicted a generalized flow battery system, the various embodiments of the present disclosure will now be described in more detail with reference to the drawings. FIGURES 2-6 show illustrative configurations of single electrochemical unit cells that can be manufactured using high-throughput manufacturing techniques. FIGURES 7 and 8 show illustrative configurations of electrochemical cell stacks incorporating a plurality of the electrochemical unit cell of FIGURE 2. Further description of these FIGURES follows hereinafter. The configurations of Figure 6 is not in accordance with the present invention. High-throughput manufacturing techniques for fabricating such electrochemical unit cells and electrochemical cell stacks are also addressed in more detail hereinbelow.

[0037] FIGURE 2 shows an exploded view of an illustrative electrochemical unit cell configuration, in which the various cell components are spaced apart from one another to show detail. In practice, the various cell components are in contact with one another, as shown in FIGURE 4, for example. Electrochemical unit cell 100 includes centrally disposed separator 102. Cathode 104 and anode 106 are abutted upon opposing sides of separator 102. Cathode 104 and anode 106 are smaller than separator 102 and are positioned such that non-contacted perimeter regions 108 and 108' are established around the periphery of separator 102 on both sides (non-contacted perimeter region 108' not shown in FIGURE 2). Compressible seals 110 and 110' are disposed within non-contacted perimeter regions 108 and 108', respectively, and contact separator 102 (compressible seal 110' not shown in FIGURE 2). FIGURE 3A shows a more detailed view from the cathode side of electrochemical unit cell 102, in which the disposition of non-contacted perimeter region 108 and its corresponding compressible seal 110 can be more clearly seen. FIGURE 3B shows a corresponding view from the anode side. As discussed in more detail hereinafter, an underlayment can be present between separator 102 and compressible seals 110 and 110'. The underlayment can provide rigidity, aid alignment during later assembly processes, control the compression of compressible seals 110 and 110', and promote bonding between dissimilar materials. Separator 102, cathode 104, anode 106, and compressible seals 110 and 110' constitute the "soft goods" or "soft goods assembly" of electrochemical unit cell 100.

[0038] The "hard goods" of electrochemical unit cell 100 will now be further described with reference to FIGURES 2, 3A and 3B. Frame layers 120 and 120' include respective windows 122 and 122'. Windows 122 and 122' are sized such that frame layers 120 and 120' fit around the outer perimeter of compressible seals 110 and 110', as shown in more detail in FIGURES 3A and 3B. The thickness of frame layers 120 and 120' can dictate the extent to which compressible seals 110 and 110' are compressed upon adding further layers, as discussed hereinafter. Although FIGURES 3A and 3B have shown frame layers 120 and 120' in direct contact with compressible seals 110 and 110', respectively, it is to be recognized that some open space can exist between the two depending on the size of windows 122 and 122'. The open space can also dictate how much compressible seals 110 and 110' can outwardly expand upon undergoing compression.

[0039] With continued reference to FIGURE 2, frame layers 130 and 130' contact frame layers

120 and 120', respectively, while also contacting compressible seals 110 and 110', respectively. Windows 132 and 132' are defined in frame layers 130 and 130', respectively. Windows 132 and 132' are smaller in size than windows 122 and 122' to allow for frame layers 130 and 130' to contact compressible seals 110 and 110'. In addition to dictating the extent to which compressible seals 110 and 110' can be compressed, frame layers 120 and 120' provide a stable structure against which frame layers 130 and 130' can provide a compressive force. Frame layers 140 and 140' contact frame layers 130 and 130', respectively, and also have windows 142 and 142' respectively defined therein. In addition, frame layers 140 and 140' contain flow distribution channels 144 and 144' defined respectively therein, which extend to the internal space defined by windows 142 and 142'. Flow distribution channels 144 and 144' allow electrolyte solutions to be provided independently (e.g., from a fluid distribution manifold) to the two half-cells of electrochemical unit cell 100. Although not shown in FIGURE 2, similar flow distribution channels can be present in frame layers 150 and 150'. Further, additional frame layers can also be present, and any of the additional frame layers not contacting compressible seals 110 and 110' can contain flow distribution channels similar to those shown in frame layers 140 and 140'.

[0040] Electrolyte solution can be provided to flow distribution channels 144 and 144' from a plurality of openings disposed within each of frame layers 120, 120', 130, 130', 140, 140', 150 and 150'. The openings define continuous flow pathways extending through electrochemical unit cell 100. More particularly, the openings provide a location for ingress and egress of electrolyte solutions to and from the corresponding half-cell upon connection of electrochemical unit cell 100 to a fluid distribution manifold. The openings on opposing sides of frame layers 120, 120', 130, 130', 140, 140', 150 and 150' are paired such that each electrolyte solution only enters a single half-cell. While FIGURE 2 has shown the plurality of openings as being substantially circular in shape, it is to be recognized that other shapes are also possible.

[0041] Still referring to FIGURE 2, electrochemical unit cell 100 also includes frame layers 150 and 150', which have windows 152 and 152' respectively defined therein. Bipolar plates 160 and 160' fill windows 152 and 152' of corresponding frame layers 150 and 150'. Bipolar plates 160 and 160' are adhered to frame layers 150 and 150', for example, by techniques such as adhesive bonding, laser welding, ultrasonic welding, hot plate welding, hot rolling, or lamination with a pressure-sensitive adhesive or thermal bonding film. Adhering bipolar plates 160 and 160' to respective frame layers 150 and 150' precludes electrolyte solution leakage around bipolar plates 160 and 160' in the finished cell. Bipolar plate 160 further extends through windows 122, 132 and 142 and contacts cathode 104. Similarly, bipolar plate 160' further extends through windows 122', 132' and 142' and contacts anode 106. The thickness of bipolar plates 160 and 160' can be chosen and adjusted to account for the overall thickness of electrochemical unit cell 100 and its various layers. Alternately, the thickness of cathode 104 and anode 104' can be chosen and adjusted similar to account for the overall thickness of electrochemical unit cell 100.

[0042] FIGURE 4 shows a section view of the electrochemical unit cell of FIGURE 2 with the

various cell components fully abutted together with one another. Frame layers 120, 130, 140 and 150 can be adhered to one another as a group, and frame layers 120, 130', 140' and 150' can be adhered to one another as a group when the various components are abutted together in the configuration of FIGURE 4. Frame layers 120 and 120' are simply abutted against one another and held in place by compressive forces in the configuration of FIGURE 4. As shown below in FIGURE 6, frame layers 120 and 120' can also be adhered to one another to collectively adhere each of the frame layers together as single group. The adherence of the various layers to one another defines chambers on opposing sides of separator 102 through which electrolyte solutions can be circulated. That is, frame layers 120, 130 and 140 together with separator 102, compressible seal 110, and bipolar plate 160 collectively define a closed chamber through which a first electrolyte solution can be flowed about cathode 104. Similarly, frame layers 120', 130', 140', separator 102, compressible seal 110' and bipolar plate 160' define a closed chamber through which a second electrolyte solution can be flowed about anode 106. Compressible seals 110 and 110' preclude overboard fluid leaks and unwanted fluid transfer between the closed chambers separately housing the first electrolyte solution and the second electrolyte solution. The volumes of the respective chambers are determined, for example, by the thickness of the various frame layers and the size of the corresponding windows. As described further hereinbelow, electrochemical cells similar to those depicted in FIGURES 2, 3A, 3B and 4 can be fabricated from materials where each component is provided from a rolled source, thereby allowing fabrication by high-throughput manufacturing processes to take place.

[0043] In the electrochemical unit cell configuration of FIGURES 2 and 4, compressible seals 110 and 110' are adhered on opposing sides of separator 102. In an alternative to the cell configuration shown in these FIGURES, compressible seals can be provided on the hard goods assembly. In some embodiments, compressible seals 110 and 110' can be defined around the perimeter of windows 122 and 122' in first frame layer 120 and second frame layer 120'. In other embodiments, compressible seals 110 and 110' can be defined upon the face of bipolar plates 160 and 160', specifically around the outer perimeter of bipolar plates 160 and 160'. These alternative sealing locations can function similarly in containing each electrolyte solution in its respective half-cell.

[0044] In more particular embodiments, each of the components of electrochemical unit cell 100 and the other electrochemical unit cells and electrochemical cell stacks of the present disclosure can be formed from a material that is provided in rolled form. That is, in some embodiments, each of the materials can be supplied in reel-to-reel manufacturing processes for producing the electrochemical cells and related electrochemical cell stacks. Further disclosure regarding illustrative manufacturing processes for the electrochemical unit cells and electrochemical cell stacks follows hereinbelow. Where not already described hereinabove, suitable materials for the various components of the electrochemical unit cells will be described in more detail next.

[0045] Each of frame layers 120, 120', 130, 130', 140, 140', 150 and 150' can be formed from a non-conductive material (e.g., an insulator), particularly a material that can be supplied in a

rolled form such as a film or sheet. In more particular embodiments, each frame layer can be formed from a thermoplastic material such as polyethylene or other polyolefin material. Additional suitable polyolefin materials can include, for example, acrylonitrile-butadiene-styrene (ABS) copolymers, polypropylene, polyvinyl chloride and the like. Non-olefinic polymers such as, for example, polyamides (e.g., nylons), polyesters, polyetherimides (e.g., ULTEM), polyimides (e.g., KAPTON), polyetherketones, polysulfones, and the like can also be suitably used. Other suitable materials for forming the various frame layers can similarly be envisioned by one having ordinary skill in the art. Choice of a particular material for forming frame layers 120, 120', 130, 130', 140, 140', 150 and 150' can be dictated, for example, by the intended operating environment and concerns related to chemical compatibility of a particular electrolyte solution contacting the frame layers.

[0046] Suitable materials for forming separator 102 can include those generally discussed above. Such separator materials can be supplied in rolled form by a number of suppliers such as DuPont, Gore, Solvay, and 3M, for example. Both porous separators and ion exchange (ionomer) membranes are available in this format.

[0047] Suitable materials for cathode 104 and anode 106 can generally include any conductive material that is conventionally used for this purpose in flow batteries and other electrochemical systems. Particular examples of suitable materials for forming an electrode are discussed above. Like the other components of the electrochemical unit cells disclosed herein, the materials for cathode 104 and anode 106 can likewise be supplied in rolled form. In more specific embodiments, at least one of cathode 104 and anode 106 can be made from a carbon felt, particularly an uncoated carbon felt. In other more specific embodiments, cathode 104 and anode 106 can be made from any conductive material in the form of a woven cloth, mesh, or screen; a non-woven paper; a film; a foil; or a sheet that can be supplied in rolled form. Particular electrode materials can include carbon and various metals that are supplied in rolled form. Non-conductive plastic materials can also constitute a portion of an electrode material being supplied in rolled form. In some embodiments, at least one of cathode 104 and anode 106 can have a catalyst deposited thereon. The catalyst, if present, can be supplied on the electrode material (e.g., in rolled form) as the electrochemical cell is being fabricated. Other layers can also be optionally present on cathode 104 and/or anode 106. Functions of the optional layers can include, for example, aiding cell assembly, improving contact resistance, and/or providing protection for separator 102. Deposition of any additional layers upon the material forming cathode 104 and/or anode 106 can occur by any of a variety of deposition techniques such as, for example, spray coating, screen printing, roller coating, gravure coating, dip coating, slot die coating, and the like. The coating can already be present on the conductive material as-supplied, or it can be introduced in a continuous process during fabrication of the electrochemical unit cells.

[0048] As indicated above, compressible seals 110 and 110' help establish coherent chambers through which first and second electrolyte solutions can separately flow. That is, functions of compressible seals 110 and 110' can include preventing overboard leaks and precluding fluid transport of the first and second electrolyte solutions around separator 102. Instead, mass

transport in electrochemical unit cell 100 and other electrochemical cells and cell stacks of the present disclosure occurs via ionic conduction across separator 102.

[0049] In more particular embodiments, compressible seals 110 and 110' can be formed from an elastomeric material. Examples of suitable elastomeric materials for forming compressible seals 110 and 110' will be familiar to one having ordinary skill in the art and can be chosen to have chemical compatibility with the electrolyte solution and/or environmental compatibility with the operating conditions of the electrochemical unit cell, for example. Suitable elastomeric materials can include, for example, silicone polymers, fluoroelastomers, ethylene propylene diene copolymer (EPDM), polytetrafluoroethylene, natural rubber, synthetic rubber, and the like. Suitable elastomeric materials can also be provided in rolled form. In more particular embodiments, a thermoplastic underlayment (not shown in FIGURES 2, 3A, 3B and 4) can be applied between separator 102 and compressible seals 110 and 110'. Like compressible seals 110 and 110', the thermoplastic underlayment also lies within non-contacted perimeter regions 108 and 108' on either side of separator 102. In more particular embodiments, compressible seals 110 and 110', the corresponding thermoplastic underlayment, and separator 102 can be adhered to one another, such as through adhesive bonding to form a soft goods assembly. Adhesive bonding can take place during fabrication of the electrochemical unit cell. Suitable adhesive bonding techniques and compositions that can be utilized in this regard include, for example, pressure-sensitive adhesives, UV-curable adhesives, thermal bonding film, epoxies, solvent-bonded adhesives, and hot-press or hot-lamination techniques. In some embodiments, at least one of compressible seals 110 and 110' can be provided in the form of an elastomeric beaded seal. In some or other embodiments, at least one of compressible seals 110 and 110' can be provided in the form of a flat elastomeric gasket.

[0050] Bipolar plates 160 and 160' can be formed of any suitable electrically conductive and substantially non-permeable material. In more specific embodiments, at least one of bipolar plates 160 and 160' can be formed from a flexible graphite foil, expanded graphite, or a metal film, foil, or sheet. Such materials can be supplied in rolled form in some embodiments. In some embodiments, at least one of bipolar plates 160 and 160' can have surface features defined thereon that function to alter the flow distribution of an electrolyte solution within one or both of the half-cells of electrochemical unit cell 100 or a similar electrochemical unit cell. For example, such surface features can help distribute an electrolyte solution evenly over the surface of cathode 104 and/or anode 106. In illustrative embodiments, the surface features can include interdigitated or quasi-interdigitated flow channels, which can be formed by both additive and subtractive production methods, such as extrusion, stamping, milling, ablation, or roller embossing.

[0051] As indicated above, bipolar plates 160 and 160' extend through windows 152 and 152', respectively, so that individual electrochemical unit cells can be combined with one another in an electrochemical stack. To provide an intact chamber through which an electrolyte solution can flow without leakage, bipolar plates 160 and 160' can be adhered to frame layers 150 and 150' and occlude windows 152 and 152' therein, respectively. In addition, bipolar plates 160 and 160' can extend through the remaining frame layers in electrochemical unit cell 100 and

contact cathode 104 and anode 106, respectively.

[0052] During fabrication of electrochemical unit cell 100 or a similar electrochemical unit cell, any of frame layers 120, 130, 140, 150, 120', 130', 140' and 150' can be supplied from a suitable rolled material and the various features (e.g., windows, flow distribution channels, headers, plenums, fluid manifolds, alignment features, and the like) therein can be defined by a suitable manufacturing technique. Suitable manufacturing techniques for defining features within the frame layers can include, for example, die-cutting, laser cutting, stamping, and the like.

[0053] Following fabrication of electrochemical unit cell 100 or a similar electrochemical unit cell, frame layers 120, 130, 140, and 150 can become collectively adhered to one another, and frame layers 120', 130', 140' and 150' can also become collectively adhered to one another. Again, this helps define coherent chambers through which first and second electrolyte solutions can flow through the two half-cells. Suitable techniques for adhering the frame layers to one another can include those listed above. Particularly suitable techniques for adhering the frame layers can include adhesive bonding techniques and compositions such as, for example, pressure-sensitive adhesives, heat-cured adhesives, and UV-cured adhesives, such as epoxies. In alternative embodiments, techniques such as laser welding, ultrasonic welding, hot plate welding, hot rolling, stir-friction welding, pressure-sensitive adhesives, or thermal bonding films can be used to adhere the frame layers to one another as appropriate.

[0054] Although electrochemical unit cell 100 contains four frame layers (i.e., 120, 130, 140 and 150, and 120', 130', 140' and 150) on each side of separator 102, it is to be recognized that additional frame layers can be present in other embodiments of the present disclosure. Additional frame layers can be added to solve particular design challenges and/or to alter the overall thickness of electrochemical unit cell 100. In some embodiments, any frame layers added to increase the thickness of electrochemical unit cell 100 can have windows defined therein so that a bipolar plate can extend therethrough, but otherwise such frame layers can lack other distinguishing structural features. In some or other embodiments, additional frame layers can include structural features appropriate to meet the needs of particular design considerations, such as flow distribution features and conduits to allow fluid introduction at a particular location within a given half-cell.

[0055] FIGURE 5 shows an exploded view of another illustrative electrochemical unit cell configuration, in which the various cell components are spaced apart from one another to show detail. Electrochemical unit cell 200 in FIGURE 5 differs primarily from electrochemical unit cell 100 of FIGURES 2, 3A, 3B and 4 in that compressible seals 110 and 110' are omitted from non-contacted perimeter regions 108 and 108', respectively. Otherwise, the elements of the electrochemical unit cell configuration in FIGURE 5 are similar to those in FIGURE 2, and like reference characters will be used as a result. Likewise, elements in common between FIGURES 2 and 5 will not be described again in detail unless their disposition differs in the alternative cell configuration.

[0056] In the cell configuration of FIGURE 5, frame layers 120 and 120' make direct contact with opposing sides of separator 102 and are adhered thereto, such as through adhesive bonding. Direct bonding of this type can function to promote sealing in manner similar to that provided by compressible seals 110 and 110' in the cell configuration of FIGURE 2. Hence, compressible seals 110 and 110' can be omitted in the electrochemical unit cell configuration of FIGURE 5. A resulting distinction between the cell configuration of FIGURE 2 and that of FIGURE 5 is that disassembly of the cell can be more difficult for the latter (*e.g.*, to conduct an analysis or examination after operating the cell for a period of time). In particular, the cell configuration of FIGURE 5 contains the two half-cells bonded to one another at separator 102, whereas the cell configuration of FIGURE 2 can be disassembled by relieving the confinement pressure of frame layers 120 and 120' upon compressible seals 110 and 110'. In alternative configurations, the cell configuration of FIGURE 6 can include compressible seals similar to those described above in reference to FIGURE 2. A seal underlayment can be present in some instances when a seal is present. Alternately, a seal underlayment can be provided as an assembly aid between separator 102 and frame layers 120 and 120'. FIGURE 6 shows a section view of the electrochemical unit cell of FIGURE 5 with the various cell components fully abutted together with one another.

[0057] As indicated above, a plurality of electrochemical unit cells can be combined with one another to produce electrochemical stacks of varying sizes. More particularly, a plurality of the electrochemical cells can be stacked upon one another such that the individual electrochemical unit cells are abutted together along an axis defined through the bipolar plates, cathode, separator and anode of the individual electrochemical unit cells. Electrical communication between the individual electrochemical unit cells takes place through the bipolar plates disposed at the axial termini of each electrochemical unit cell. Depending upon how the electrochemical unit cells are manufactured, adjacent electrochemical unit cells can either share a common bipolar plate and frame layer adhered to the bipolar plate, or bipolar plates from adjacent electrochemical cells within the electrochemical stack can be abutted against one another (*i.e.*, in a head-to-tail fashion).

[0058] In some embodiments, bipolar plates from adjacent electrochemical unit cells within an electrochemical stack can be abutted against one another. FIGURE 7 shows a schematic of an illustrative electrochemical stack in which bipolar plates from adjacent electrochemical cells are abutted against one another. The individual electrochemical unit cells in FIGURE 7 have a cell configuration similar to that shown in FIGURE 4 and will not be described again in detail. The cell configuration of FIGURE 6 can be employed similarly. FIGURE 7 shows illustrative three-cell electrochemical stack 300. Electrochemical stack 300 contains electrochemical unit cells 302a, 302b and 302c, which have been placed head-to-tail with respect to each other. That is, in adjacent electrochemical cells 302a and 302b, bipolar plates 310a' and 310b abut one another, and bipolar plates 310' and 310c abut one another in adjacent electrochemical cells 302b and 302c. Bipolar plates 310a and 310c' lie at the axial termini of electrochemical stack 300 and do not abut another bipolar plate. Similarly, frame layers 320a' and 320b abut one another, as do frame layers 320b' and 320c. Frame layers 320a and 320c' lie at the axial termini and do not abut another frame layer.

[0059] In alternative embodiments, adjacent electrochemical unit cells within the electrochemical stack can share a common bipolar plate. FIGURE 8 shows a schematic of an illustrative electrochemical stack in which adjacent electrochemical cells share a common bipolar plate. Again, the individual electrochemical unit cells in FIGURE 8 have a cell configuration similar to that shown in FIGURE 4 and will not be described again in detail. The cell configuration of FIGURE 6 can be employed similarly. FIGURE 8 shows illustrative three-cell electrochemical stack 400. Electrochemical stack 400 contains electrochemical unit cells 402a, 402b and 402c, where a common bipolar plate and frame layer is shared between adjacent electrochemical unit cells. Ultimately, electrochemical unit cells 402a-402c are the same as those shown in FIGURES 2 and 7, except for lacking a second bipolar plate and corresponding frame layer about the second bipolar plate. Accordingly, the repeat unit within electrochemical stack 400 differs from that of electrochemical stack 300. With more particular reference to FIGURE 8, adjacent electrochemical unit cells 402a and 402b share bipolar plate 410b, and adjacent electrochemical unit cells 402b and 402c share bipolar plate 410c. Bipolar plates 410a and 410d and frame layers 420a and 420d lie at the axial termini of electrochemical stack 400 and are not shared with another electrochemical unit cell. Similarly, frame layer 420b is shared between adjacent electrochemical unit cells 402a and 402b, and frame layer 420c is shared between adjacent electrochemical unit cells 402b and 402c. Electrochemical stack configurations similar to those shown in FIGURE 8 can be prepared by downstream modification of the manufacturing processes disclosed herein.

[0060] Although electrochemical stacks 300 and 400 in FIGURES 7 and 8 have shown the particular electrochemical unit cell configuration shown in FIGURE 4, it is to be recognized that similar electrochemical stacks can be produced using the electrochemical unit cell configuration of FIGURE 6 as well. In addition, depending on various operational considerations, differing unit cell configurations can be present in a given electrochemical stack in some embodiments of the present disclosure. Further, in some embodiments, the electrochemical stack configuration of FIGURE 8 can be iteratively stacked to produce even larger electrochemical stacks. For example, a 3-cell stack configuration similar to that shown in FIGURE 8 can be iteratively stacked ten times to produce a 30-cell electrochemical stack. Alternately, the individual electrochemical unit cells from the electrochemical stack configuration of FIGURE 7 can also be incorporated in a modified electrochemical stack containing the stack configuration of FIGURE 8. Accordingly, the electrochemical stack configurations depicted in FIGURES 7 and 8 should not be considered limiting.

[0061] Likewise, although FIGURES 7 and 8 have depicted three-cell electrochemical stacks, it is to be understood that any number of individual electrochemical unit cells can be present depending on the desired amount of power to be stored and other operational considerations. Accordingly, the depicted electrochemical stack configurations of FIGURES 7 and 8 should not be considered limiting. In various embodiments, electrochemical stacks can contain between about 30 and 200 individual electrochemical unit cells, or between about 50 and about 100 individual electrochemical unit cells, or between about 100 and about 200 individual electrochemical unit cells. Interconnection of the various electrochemical unit cells in an

electrochemical stack can take place through any of the adherence techniques described herein, such as adhesive bonding, hot pressing, lamination, laser welding, ultrasonic welding, and the like.

[0062] As indicated above, the electrochemical unit cells of the present disclosure can be fabricated by various high-throughput manufacturing techniques, such as reel-based manufacturing techniques. Illustrative manufacturing techniques for the electrochemical unit cells of the present disclosure will now be described in more detail.

[0063] Ultimately, it can be desirable to fabricate the electrochemical unit cells and related electrochemical cell stacks of the present disclosure in a "unitized" fashion by concurrently processing both the soft goods and the hard goods along a single production line. It is to be recognized, however, that the electrochemical unit cells can also be fabricated by processing the soft goods and the hard goods in separate production lines and then combining the hard goods and soft goods together to form completed electrochemical unit cells. In order to facilitate a better understanding of the "unitized" production process, separate fabrication processes for the soft goods and the hard goods will be described first.

[0064] FIGURE 9 shows a schematic of an illustrative production line that can combine the soft goods of an electrochemical unit cell in a continuous fashion. As depicted in FIGURE 9, each of the source materials forming the soft goods are supplied from a rolled source. These source materials, where appropriate, will be referred to by their reference characters from FIGURES 2-8, and FIGURE 9 may be better understood by reference to these preceding FIGURES.

[0065] As shown in FIGURE 9, reel 502 supplies a roll of separator 102 to production line 500. Separator 102 undergoes lamination to an underlayment at station 505 containing rollers 506. Prior to reaching station 505, a roll of the underlayment is supplied from reels 508, and pressure-sensitive adhesive is laminated onto opposing faces of the underlayment at stations 511, which contains rollers 512. Layers of the pressure-sensitive adhesive are supplied from reels 514. Die-cutting or similar modification of the underlayment and the pressure-sensitive adhesive occurs at stations 519 using dies 520. Die-cutting defines apertures (windows) within which cathode 104 and anode 106 can contact separator 102 upon attachment of the underlayment thereto. Exposure of one of the layers of pressure-sensitive adhesive takes place by winding its backing material onto reel 522.

[0066] After lamination of the underlayment and pressure-sensitive adhesive to separator 102 at station 505, exposure of the other layer of pressure-sensitive adhesive takes place by winding its backing material onto reels 524. Thereafter, separator 102 and the adhered underlayment pass to station 525, where adhesive bonding to compressible seals 110 and 110' takes place. Station 525 contains rollers 526, which laminate the pressure-sensitive adhesive onto separator 102 to complete the adhesive bonding process. Other bonding techniques can be similarly employed.

[0067] Prior to reaching station 525, a roll of a sealing material forming compressible seals 110

and 110' is supplied from reels 528. Die-cutting or similar definition of the sealing material occurs at stations 529 using dies 530. As with the underlayment, die-cutting defines apertures (windows) within which cathode 104 and anode 106 can contact separator 102. The apertures defined at stations 529 are substantially the same size as those defined at stations 511 so that the perimeter-disposed compressible seals 110 and 110' have an underlayment of substantially the same lateral size.

[0068] After exiting station 525, the separator-compressible seal laminate passes to station 529, where dies 530 cut the outer perimeter of the separator-compressible seal laminate. This defines the ultimate size of the electrochemical cells, particularly the hard goods that subsequently become attached thereto, as discussed hereinafter. Sheeting of the die-cut separator-compressible seal laminate then takes place at station 531 for further assembly into an electrochemical unit cell or an electrochemical unit cell stack. FIGURES 10A and 10B show illustrative top and side-view schematics of soft goods assembly 540 produced by the production line of FIGURE 9, wherein underlayments 542 and 542' intervene between separator and compressible seals 110 and 110', respectively. Additional layers constituting the pressure-sensitive adhesive are not shown in FIGURES 10A and 10B in the interest of clarity. FIGURE 10C shows a simplified rendition of FIGURE 10B with underlayments 542 and 542' omitted for clarity.

[0069] As mentioned above, cathode 104 and anode 106 are usually considered to be part of the soft goods of an electrochemical unit cell. In the interest of simplicity, mechanisms for the placement of cathode 104 and anode 106 have not been depicted in FIGURE 9. Illustrative locations in production line 500 where cathode 104 and anode 106 could be introduced from a rolled source material include, for example, just before station 505 or station 525. In FIGURES 10A-10C, cathode 104 and anode 106 are shown disposed in phantom in soft goods assembly 540 to illustrate their positions relative to the other components assembled in production line 500. Incorporation of cathode 104 and anode 106 within an electrochemical unit cell will be discussed in further detail hereinbelow in a unitized process for jointly assembling hard goods and soft goods into an electrochemical unit cell.

[0070] Turning now to the hard goods, FIGURE 11 shows a schematic of an illustrative production line that can combine the hard goods of an electrochemical unit cell in a continuous fashion. As depicted in FIGURE 11, each of the source materials forming the hard goods are supplied from a rolled source. Again, the source materials, where appropriate, will be referred to by their reference characters from FIGURES 2-8, and FIGURE 11 may be better understood by reference to these preceding FIGURES.

[0071] More specifically, reel 602 supplies a roll of a material forming frame layer 150 to production line 600. Suitable materials for forming frame layer 150 and the other frame layers are discussed above. The frame layer material is then die-cut or similarly defined at station 605 using dies 606 to form an aperture that ultimately is refilled with bipolar plate 160. Adhesive is then applied at station 607 from bath 608 and rollers 609. Although station 607 is depicted as a gravure-type printing roll, it is to be recognized that in alternative embodiments, the adhesive

can be applied by screen printing, spray coating, dip coating, roll coating, slot die coating, and similar deposition techniques. The adhesive-coated material is then passed to station 611 for attachment of bipolar plate 160.

[0072] A material forming bipolar plate 160 is supplied from reel 614 and passes to station 611 containing rollers 612. Upon reaching station 611, the bipolar plate material and the adhesive-coated frame layer material pass through rollers 612 that result in adherence of the bipolar plate material to the adhesive-coated frame layer. The bipolar plate material occludes the aperture previously defined in the frame layer material at station 605. Various bonding mechanisms can be applied at station 611. In illustrative embodiments, the bipolar plate material can be joined to the adhesive-coated frame layer by cold lamination, hot lamination, UV curing, heat curing, laser welding, ultrasonic welding, and the like. Heat curing, for example, can be applied by passing the bipolar plate material and the frame layer material through a furnace, heating coil, hot air blower, or like thermal source. Choice of a suitable technique to promote adhesive bonding will depend upon the chosen adhesive applied at station 607, and such considerations are considered to lie within the understanding of one having ordinary skill in the art.

[0073] After exiting station 611, the frame layer material and its adhered bipolar plate material enter a series of stations in which the materials forming frame layers 120, 120', 130, 130', 140 and 140' are added sequentially upon the material forming frame layer 150. Specifically, the materials for frame layers 140 and 140' are applied at station 621, the materials for frame layers 130 and 130' are applied at station 631, and the materials for frame layers 120 and 120' are applied at station 641. Materials for each of the foregoing frame layers applied at stations 621, 631 and 641 are provided from supply arms 620, 630 and 640, each of which operate similarly in supplying the frame layer material, as discussed hereinafter. Stations 621, 631 and 641 respectively contain rollers 624, 634 and 644 that facilitate the lamination process of the various layers to one another.

[0074] In brief, supply arms 620, 630 and 640 each contain reels 650 and 652, which supply a frame layer material and a pressure-sensitive adhesive in rolled form. The frame layer material and the pressure-sensitive adhesive undergo lamination at stations 653, which contain rollers 654. After exiting stations 653, the frame layer-adhesive laminate travels to station 655 containing dies 656, where die-cutting takes place to define apertures in the respective frame layers. These apertures ultimately become windows 122, 122', 132, 132', 142 and 142' in the completed electrochemical unit cell. A backing material from one side of the pressure-sensitive adhesive is also removed at station 655 from the outward-facing surface of the pressure-sensitive adhesive and is wound onto roller 658.

[0075] Upon exiting station 641, a 7-layer laminate is present (see FIGURES 12A and 12B), which does not include any layers represented by the pressure-sensitive adhesive. The outer perimeter of the 7-layer laminate is then die-cut at station 661 using dies 662. The die-cutting at station 661 is conducted so that the hard goods are complementary in size with the soft goods fabricated in production line 500. As with production line 500, sheeting of the finished

hard goods assembly takes place at station 671.

[0076] FIGURES 12A and 12B show illustrative top and side-view schematics of hard goods assembly 680 fabricated by the production line of FIGURE 11. As shown in FIGURE 12A, bipolar plate 160 is adhered to frame layer 150 and occludes the aperture (window) initially defined therein. Overlaying frame layer 150 are successive frame layers 140, 130 and 120, and 140', 130' and 120' (only frame layer 120 visible in FIGURE 12A). Each of frame layers 120, 120', 130, 130', 140 and 140' have open apertures, leaving bipolar plate 160 uncovered. The 7-layer laminate structure of hard goods assembly 680 can be seen more clearly in FIGURE 12B. As shown in FIGURE 12B, frame layer 150 is disposed centrally in the 7-layer laminate and has bipolar plate 160 (shown in phantom) adhered on opposing sides of frame layer 150. Although FIGURE 12 B has shown bipolar plate 160 (in phantom) as residing solely within frame layer 150, it is to be understood that bipolar plate 160 can also extend through the open apertures in frame layers 120, 130, 140, 120', 130' and 140', as discussed above. Alternately, cathode 104 and anode 106 can extend through the apertures to contact bipolar plate 160. Also on opposing sides of frame layer 150 are successively disposed frame layers 140, 130 and 120, and 140', 130' and 120'. Between each frame layer, pressure-sensitive adhesive layers 682 are also present. Alternative techniques for adhering the various frame layers to one another can also be used. FIGURE 12C shows a simplified rendition of the configuration of FIGURE 12B with pressure-sensitive adhesive layers 682 omitted for clarity.

[0077] As mentioned above, additional or fewer frame layers can be included in the electrochemical unit cells of the present disclosure, as dictated by various operational needs. Given the benefit of the present disclosure, one of ordinary skill in the art can readily adapt the production processes described herein to produce a hard goods assembly and corresponding electrochemical unit cell with any number of suitable frame layers.

[0078] By alternately stacking soft goods assembly 540 and hard goods assembly 680, an electrochemical stack similar to that shown in FIGURE 8 can be produced, in which bipolar plate 160 and frame layer 150 are shared between adjacent electrochemical unit cells. FIGURE 13 shows a schematic of an illustrative 3-cell electrochemical stack in which the soft goods assembly of FIGURES 10A-10C and the hard goods assembly of FIGURES 12A-12C are stacked in an alternating manner. More particularly, electrochemical stack 700 contains alternating placement of hard goods assembly 680a-d and soft goods assembly 540a-c, which defines electrochemical unit cells 702a-c. Electrochemical unit cells 702a-c share bipolar plates in common. Electrochemical unit cells 702a and 702c at the upper and lower termini of electrochemical stack 700 differ slightly from the configuration depicted in FIGURE 8 in that bipolar plates 410a and 410d do not terminate electrochemical stack 700. Instead, additional frame layers from hard goods assemblies 680a and 680d terminate electrochemical stack 700 and can be used for mating additional electrochemical cells, if desired. The additional frame layers in hard goods assemblies 680a and 680d can be terminated with an appropriate part in subsequent manufacturing step. Alternately, hard goods assemblies 680a and 680d can be manufactured separately with frame layers only on a single side.

[0079] Processes for directly producing electrochemical unit cells in a unitized manner by fabricating both a soft goods assembly and a hard goods assembly in a single production line and combining them will now be described in further detail. Such electrochemical unit cells can have bipolar plates from adjacent electrochemical unit cells abutted against one another in an electrochemical stack, such as the configuration shown in FIGURE 7. Contact pressure between the abutted bipolar plates can establish electrical conductivity between the adjacent electrochemical unit cells. A particular advantage of fabricating electrochemical unit cells using the combined production line described hereinafter is that the soft goods assembly is completely sandwiched between two hard goods assemblies upon completion of the manufacturing process, thereby helping to protect the fragile separator therein from damage.

[0080] FIGURE 14 shows a schematic of an illustrative production line that can produce an electrochemical unit cell in a continuous fashion. As depicted in FIGURE 14, each of the source materials forming the soft goods and the hard goods are supplied from a rolled source. Again, the source materials, where appropriate, will be referred to by their reference characters from FIGURES 2-8, and FIGURE 14 may be better understood by reference to these preceding FIGURES.

[0081] As shown in FIGURE 14, reel 802 supplies a roll of separator 102 to production line 800. Reels 804 and 806 similarly supply a roll of materials forming cathode 104 and anode 106. Lamination of cathode 104 and anode 106 to separator 102 takes place at station 809 containing rollers 810. Suitable lamination techniques that can be applied at station 809 include, for example, hot lamination, cold lamination, printing, adhesive bonding (e.g., using a pressure-sensitive adhesive), and the like. Although not shown in FIGURE 14, the materials forming cathode 104 and anode 106 can be treated in some manner to facilitate their lamination to separator 102. For example, the edges of cathode 104 and anode 106 can be impregnated with a thermoplastic material to provide a suitable location for pressure-sensitive bonding to occur. Mechanisms similar to those shown in FIGURE 9 can be utilized to apply a pressure-sensitive adhesive. Since production line 800 produces an electrochemical unit cell similar to that of FIGURE 7, certain differences are present in the soft goods processed in production line 800 compared to those processed in production line 500 in FIGURE 9. However, one having ordinary skill in the art can readily understand how production line 500 would be modified to process the soft goods in a manner consistent with FIGURE 14. Upon passing the resulting laminate to station 813 which contains dies 814, partial die-cutting of the outer perimeter (e.g., a kiss cut) can take place to ready the soft goods for further adherence of the hard goods thereto. The scrap material from die-cutting can then be rewound onto reels 818.

[0082] The resulting soft goods assembly leaving station 813 can then have the various layers of the hard goods assembly applied at stations 841, 861 and 881 using materials received from supply arms 840, 860 and 880, respectively. Each of these lamination operations are described in further detail below.

[0083] Supply arm 840 provides materials for forming frame layers 120 and 120' from reels

820. A pressure-sensitive adhesive is unwound from reels 822 and undergoes lamination to the frame layer material at stations 825, which contain rollers 826. The resulting laminate passes to stations 829 for die-cutting with dies 830. Die-cutting defines apertures in the frame layer material which ultimately becomes windows 122 and 122'. The exposed backing layer of the pressure-sensitive adhesive is then removed and can be rewound on reel 832.

[0084] Supply arm 840 also provides materials for forming frame layers 130 and 130' from reels 834, and die-cutting of this material subsequently takes place at stations 835 using dies 836. Die-cutting defines apertures that ultimately become windows 132 and 132'. Lamination of the die-cut material of frame layers 130 and 130' to the exposed pressure-sensitive adhesive on frame layers 120 and 120' then takes place at stations 837 containing rollers 838. The resulting laminate of frame layers 120, 120', 130 and 130' then progresses to station 841 and undergoes lamination to the soft goods assembly using rollers 839. Alternately, the materials for forming frame layers 120 and 120' can be laminated to the soft goods assembly separately from that of frame layers 130 and 130', in which case the materials for frame layers 130 and 130' can be provided from a separate supply arm.

[0085] Supply arm 860 provides materials for forming frame layers 140 and 140'. Supply arm 860 is substantially similar to that of supply arm 630 in FIGURE 11 and will be described only in brief as a result. Namely, supply arm 860 contain reels 862 and 864, which respectively provide a frame layer material and a pressure-sensitive adhesive in rolled form. The frame layer material and the pressure-sensitive adhesive undergo lamination at stations 865, which contains rollers 866. After exiting stations 865, the resulting laminate of the frame layer material and pressure-sensitive adhesive travels to station 867, where die-cutting with dies 868 defines apertures which ultimately become windows 142 and 142' and flow channels 144 and 144' within frame layers 140 and 140'. The backing layer for the pressure-sensitive adhesive is then removed and can be rewound at reel 870. Thereafter, the frame layer material undergoes lamination to the frame layers 130 and 130' at station 861 containing rollers 860.

[0086] Supply arm 880 provides materials for forming frame layers 150 and 150' and bipolar plates 160 and 160'. Namely, supply arm 880 contains reels 882 and 884, which respectively provide a frame layer material and a pressure-sensitive adhesive in rolled form. The frame layer material and the pressure-sensitive adhesive undergo lamination at stations 885, which contains rollers 886. After exiting stations 886, the resulting laminate of the frame layer material and pressure-sensitive adhesive travels to station 887, where die-cutting with dies 888 defines apertures that ultimately become windows 152 and 152' within frame layers 150 and 150'. Adhesive is then applied at station 891 from bath 890 and rollers 892. As discussed above in reference to FIGURE 11, adhesive can also be applied to the frame layer material in other manners as well. The adhesive-coated material is then passed to station 895 for attachment of bipolar plates 160 and 160'.

[0087] Materials for forming bipolar plates 160 and 160 are supplied from reels 894 and pass to station 895. Upon reaching station 895, the bipolar plate material and the adhesive-coated frame layer material from station 891 pass through rollers 898 that result in adherence of the

bipolar plate material to the adhesive-coated frame layer. The bipolar plate material occludes the apertures (i.e., windows 152 and 152) that were previously defined in the frame layer material at station 887. Various bonding techniques can be applied at station 895, such as those discussed above in reference to FIGURE 11.

[0088] The backing layer for the pressure-sensitive adhesive is then removed and can be rewound at reel 900. Afterward, the resulting laminate of the frame layer material and the adhesively bonded bipolar plate material progress to station 881 containing rollers 880 for lamination to frame layers 140 and 140'. Die-cutting can then take place at station 903 using dies 904 to define a completed electrochemical unit cell, similar to that shown in FIGURE 6. Sheeting of the finished electrochemical unit cells can then take place at station 905.

[0089] Although FIGURE 14 has shown the continuous production of a single electrochemical cell, it is to be recognized that additional soft goods assemblies and hard goods assemblies can be incorporated into a single production line to fabricate electrochemical stacks having more than one electrochemical unit cell. For example, multiple production lines 800 can operate in parallel, and the finished electrochemical units cells exiting each production line can be autonomously abutted together to form an electrochemical cell stack. Alternately, production line 800 can be further modified to stack individual electrochemical unit cells upon one another without resorting to multiple production lines. Still further alternately, multiple electrochemical unit cells can be laminated to one another by stacking individual electrochemical unit cells upon one another in a manual, automated, or semi-automated fashion outside a continuous production line environment. Suitable techniques for adhering the adjacent electrochemical unit cells to one another can include, for example, adhesive bonding, laser welding, hot pressing, ultrasonic welding, mechanical fastening, and the like. Alternately, the adjacent electrochemical unit cells in an electrochemical stack can be compressed with one another without becoming adhered together.

[0090] The flow batteries incorporating electrochemical unit cells of the present disclosure are, in some embodiments, suited to sustained charge or discharge cycles of several hour durations. As such, they can be used to smooth energy supply/demand profiles and provide a mechanism for stabilizing intermittent power generation assets (e.g., from renewable energy sources such as solar and wind energy). It should be appreciated, then, that various embodiments of the present disclosure include energy storage applications where such long charge or discharge durations are desirable. For example, in non-limiting examples, the flow batteries can be connected to an electrical grid to allow renewables integration, peak load shifting, grid firming, baseload power generation and consumption, energy arbitrage, transmission and distribution asset deferral, weak grid support, frequency regulation, or any combination thereof. When not connected to an electrical grid, the flow batteries can be used as power sources for remote camps, forward operating bases, off-grid telecommunications, remote sensors, the like, and any combination thereof. Further, it is to be appreciated that electrochemical energy storage media other than flow batteries can also incorporate the electrochemical unit cells disclosed herein, including those utilizing stationary electrolyte solutions.

[0091] In additional embodiments, electrochemical unit cells, electrochemical cell stacks, and flow batteries of the present disclosure can be incorporated into larger energy storage systems, suitably including piping and controls useful for operation of these large units. Piping, control, and other equipment suitable for such systems are known in the art, and can include, for example, piping and pumps in fluid communication with the respective chambers for moving electrolyte solutions into and out of the cells and storage tanks for holding charged and discharged electrolytes. An operation management system can also be present. The operation management system can be any suitable controller device, such as a computer or microprocessor, and can contain logic circuitry that sets operation of any of the various valves, pumps, circulation loops, and the like.

[0092] Where not otherwise defined hereinabove or understood by one having ordinary skill in the art, the definitions in the following paragraphs will be applicable to the present disclosure.

[0093] As used herein, the term "energy density" will refer to the amount of energy that can be stored, per unit volume, in the active materials. Energy density refers to the theoretical energy density of energy storage and can be calculated by Equation 1:

$$\text{Energy density} = (26.8 \text{ A-h/mol}) \times \text{OCV} \times [\text{e}^-] \quad (1)$$

where OCV is the open circuit potential at 50% state of charge, (26.8 A-h/mol) is Faraday's constant, and $[\text{e}^-]$ is the concentration of electrons stored in the active material at 99% state of charge. In the case that the active materials largely are an atomic or molecular species for both the positive and negative electrolyte, $[\text{e}^-]$ can be calculated by Equation 2 as:

$$[\text{e}^-] = [\text{active materials}] \times N / 2 \quad (2)$$

where [active materials] is the molar concentration of the active material in either the negative or positive electrolyte, whichever is lower, and N is the number of electrons transferred per molecule of active material. The related term "charge density" will refer to the total amount of charge that each electrolyte contains. For a given electrolyte, the charge density can be calculated by Equation 3

$$\text{Charge density} = (26.8 \text{ A-h/mol}) \times [\text{active material}] \times N \quad (3)$$

where [active material] and N are as defined above.

[0094] As used herein, the term "current density" will refer to the total current passed in an electrochemical cell divided by the geometric area of the electrodes of the cell and is commonly reported in units of mA/cm².

[0095] As used herein, the term "current efficiency" (η_{eff}) can be described as the ratio of the total charge produced upon discharge of a cell to the total charge passed during charging. The current efficiency can be a function of the state of charge of the flow battery. In some non-limiting embodiments, the current efficiency can be evaluated over a state of charge range of about 35% to about 60%.

[0096] As used herein, the term "voltage efficiency" can be described as the ratio of the observed electrode potential, at a given current density, to the half-cell potential for that electrode ($\times 100\%$). Voltage efficiencies can be described for a battery charging step, a

discharging step, or a "round trip voltage efficiency." The round trip voltage efficiency ($V_{\text{eff,RT}}$) at a given current density can be calculated from the cell voltage at discharge ($V_{\text{discharge}}$) and the voltage at charge (V_{charge}) using equation 4:

$$V_{\text{eff,RT}} = V_{\text{discharge}} / V_{\text{charge}} \times 100\% \quad (4)$$

[0097] As used herein, the terms "negative electrode" and "positive electrode" are electrodes defined with respect to one another, such that the negative electrode operates or is designed or intended to operate at a potential more negative than the positive electrode (and vice versa), independent of the actual potentials at which they operate, in both charging and discharging cycles. The negative electrode may or may not actually operate or be designed or intended to operate at a negative potential relative to a reversible hydrogen electrode. The negative electrode is associated with a first electrolyte solution and the positive electrode is associated with a second electrolyte solution, as described herein. The electrolyte solutions associated with the negative and positive electrodes may be described as negolytes and posolytes, respectively.

REFERENCES CITED IN THE DESCRIPTION

Cited references

This list of references cited by the applicant is for the reader's convenience only. It does not form part of the European patent document. Even though great care has been taken in compiling the references, errors or omissions cannot be excluded and the EPO disclaims all liability in this regard.

Patent documents cited in the description

- [JPH087913A \[0007\]](#)
- [CN103579658A \[0008\]](#)
- [US2004241525A1 \[0009\]](#)
- [WO2008073679A1 \[0010\]](#)

Patentkrav**1. Elektrokemisk enhedscelle (200) omfattende:**

- 5 en separator (102), der er anbragt mellem en første elektrode (104) og en anden elektrode (106);
- hvor den første elektrode (104) og den anden elektrode (106) er dimensioneret og placeret således, at første og anden perimeterregion (108, 108'), der ikke er i kontakt med den første (104) og anden elektrode (106), findes på modstående sider af separatoren (102);
- 10 en første bipolar plade (160) i kontakt med den første elektrode (104);
- en anden bipolar plade (160') i kontakt med den anden elektrode (106);
- en første komprimerbar tætning (110), der er anbragt på separatoren (102) i det første perimeterområde (108);
- 15 en anden komprimerbar tætning (110'), der er anbragt på separatoren (102) i det andet perimeterområde (108');
- et første rammelag (120) og et andet rammelag (120'), der er defineret omkring en ydre omkreds af den første komprimerbare tætning (110) og den anden komprimerbare tætning (110'),
- hvor det første rammelag har et første vindue (122) defineret deri, og det andet rammelag har et andet vindue (122') defineret deri;
- 20 et tredje rammelag (130) i kontakt med den første komprimerbare tætning (110) og med det første rammelag (120);
- et fjerde rammelag (130') i kontakt med den anden komprimerbare tætning (110') og med det andet rammelag (120'),
- 25 hvor det tredje rammelag har et tredje vindue (132) defineret deri, og det fjerde rammelag har et fjerde vindue (132') defineret deri,
- hvor det tredje vindue 132 er mindre end det første vindue 122, og det fjerde vindue 132' er mindre end det andet vindue 122', således at det tredje rammelag 130 er i kontakt med den første komprimerbare tætning (110'), og det fjerde rammelag (130') er i kontakt med den anden komprimerbare tætning (110');
- 30 et femte rammelag (140) stødende op til det tredje rammelag (130);
- et sjette rammelag (140') stødende op til det fjerde rammelag (130');

et syvende rammelag (150) stødende op til det femte rammelag (140);
hvor den første bipolarære plade (160) er klæbet til det syvende rammelag (150)
og okkluderer et vindue (152) deri;

5 og et ottende rammelag (150') stødende op til det sjette rammelag (140');
hvor den anden bipolarære plade (160') er klæbet til det ottende rammelag (150')
og okkluderer et vindue (152') deri; og

hvor ethvert af rammelagene omfatter et ikke-ledende materiale, hvor mindst
ét af det femte rammelag og det sjette rammelag har en strømingsfordelings-
kanal defineret deri.

10

2. Elektrokemisk enhedscelle ifølge krav 1, hvor det femte rammelag er i kon-
takt med det tredje rammelag, det sjette rammelag er i kontakt med det fjerde
rammelag, det syvende rammelag er i kontakt med det femte rammelag, og
ottende rammelag er i kontakt med det sjette rammelag.

15

3. Elektrokemisk enhedscelle ifølge krav 1, hvor separatoreen, den første elek-
trode, den anden elektrode, den første bipolarære plade, den anden bipolarære
plade, den første komprimerbare tætning, den anden komprimerbare tætning
og ethvert af rammelagene er fremstillet af en valset kildemateriale.

20

4. Elektrokemisk enhedscelle ifølge krav 1, hvor det første, tredje, femte og
syvende rammelag er kollektivt klæbet til hinanden, og det andet, fjerde, sjette
og ottende rammelag er kollektivt klæbet til hinanden.

25

5. Elektrokemisk stabel, der omfatter:

en flerhed af de elektrokemiske enhedsceller ifølge krav 1, der støder sammen
med hinanden.

30

6. Elektrokemisk stabel ifølge krav 5, hvor tilstødende elektrokemiske enheds-
celler i den elektrokemiske stabel deler en fælles bipolarære plade og et fælles
rammelag, der er klæbet til den fælles bipolarære plade; eller hvor tilstødende
elektrokemiske enhedsceller inden i den elektrokemiske stabel har en bipolarære

plade fra en første elektrokemisk enhedscelle, der er stødt sammen med en bipolær plade fra en anden elektrokemisk enhedscelle.

7. Fremgangsmåde til dannelse af en elektrokemisk enhedscelle ifølge et hvilket som helst af kravene 1 til 4, omfattende:
- 5 tilførsel af ruller af et separatomateriale, et katodemateriale og et anodemateriale til en produktionslinje;
- klæbning af katodematerialet og anodematerialet på modstående sider af separatomaterialet på et første sted i produktionslinjen, hvorved der dannes en
- 10 samling af bløde varer;
- tilførsel af ruller af et første isolatormateriale og et andet isolatormateriale til produktionslinjen;
- definering af vinduer inden i det første isolatormateriale, således at der tilvejebringes et første rammelag, og det andet isolatormateriale tilvejebringer således et andet rammelag i produktionslinjen, klæbning af det første og andet
- 15 rammelag på modstående sider af den bløde varesamling i produktionslinjen, og klæbning af et tredje rammelag på det første rammelag og et fjerde rammelag på det andet rammelag i produktionslinjen, hvor det tredje rammelag og det fjerde rammelag omfatter det andet isolatormateriale;
- 20 tilførsel af ruller af et tredje isolatormateriale til produktionslinjen;
- definering af vinduer i det tredje isolatormateriale i produktionslinjen, således at der tilvejebringes et tredje rammelag og et sjette rammelag, og klæbning af det femte rammelag på det tredje rammelag og det sjette rammelag på det fjerde rammelag i produktionslinjen;
- 25 tilførsel af ruller af et fjerde isolatormateriale og et bipolært plademateriale til produktionslinjen; og
- definering af vinduer inden for det fjerde isolatormateriale i produktionslinjen, hvilket giver et syvende rammelag og et ottende rammelag, klæbning af det bipolære plademateriale til det fjerde isolatormateriale i produktionslinjen, således at vinduerne i det fjerde isolatormateriale er okkluderet af det bipolære
- 30 plademateriale, og

klæbning af det syvende rammelage til det femte rammelage og det ottende rammelage til det sjette rammelage i produktionslinjen, hvorved der defineres en elektrokemisk enhedscelle;

5 hvor vinduerne inden i det første isolatormateriale, det andet isolatormateriale og det tredje isolatormateriale overlapper hinanden, når de er anbragt som det første, andet, tredje, fjerde, femte og sjette rammelage; og hvor det bipolarære plademateriale kommer i kontakt med katodematerialet og anodematerialet på modstående sider af den bløde varesamling.

10 **8.** Fremgangsmåde ifølge krav 7, yderligere omfattende:

at klæbe det første isolatormateriale og det andet isolatormateriale til hinanden før klæbning af det første rammelage og det andet rammelage på den bløde varesamling; eller

15 at forbinde en flerhed af de elektrokemiske enhedsceller med hinanden i serie, hvor tilstødende elektrokemiske enhedsceller i den elektrokemiske stabel har en bipolarære plade fra en første elektrokemisk enhedscelle, der er stødt sammen med en bipolarære plade fra en anden elektrokemisk enhedscelle.

20 **9.** Fremgangsmåde ifølge krav 7, hvor katodematerialet og anodematerialet klæbes til separator materialet under anvendelse af et trykfølsomt klæbemiddel; eller hvor ethvert af rammelagene er kollektivt klæbet til hinanden.

DRAWINGS

Drawing

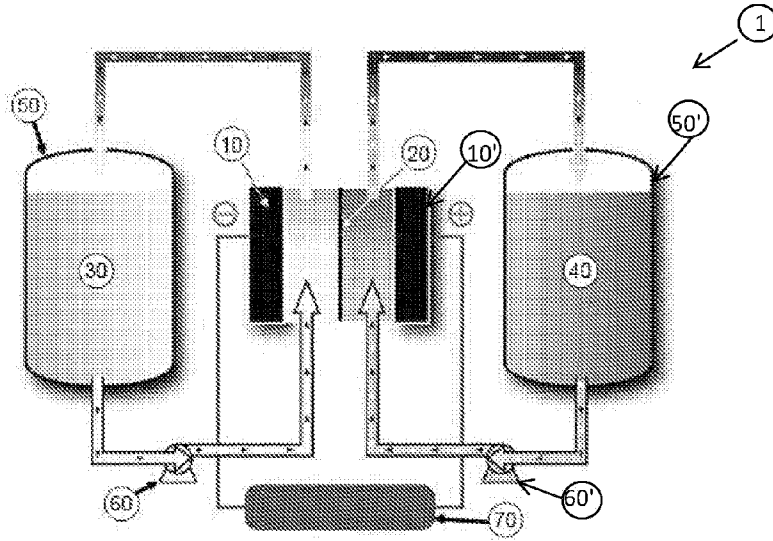

FIGURE 1

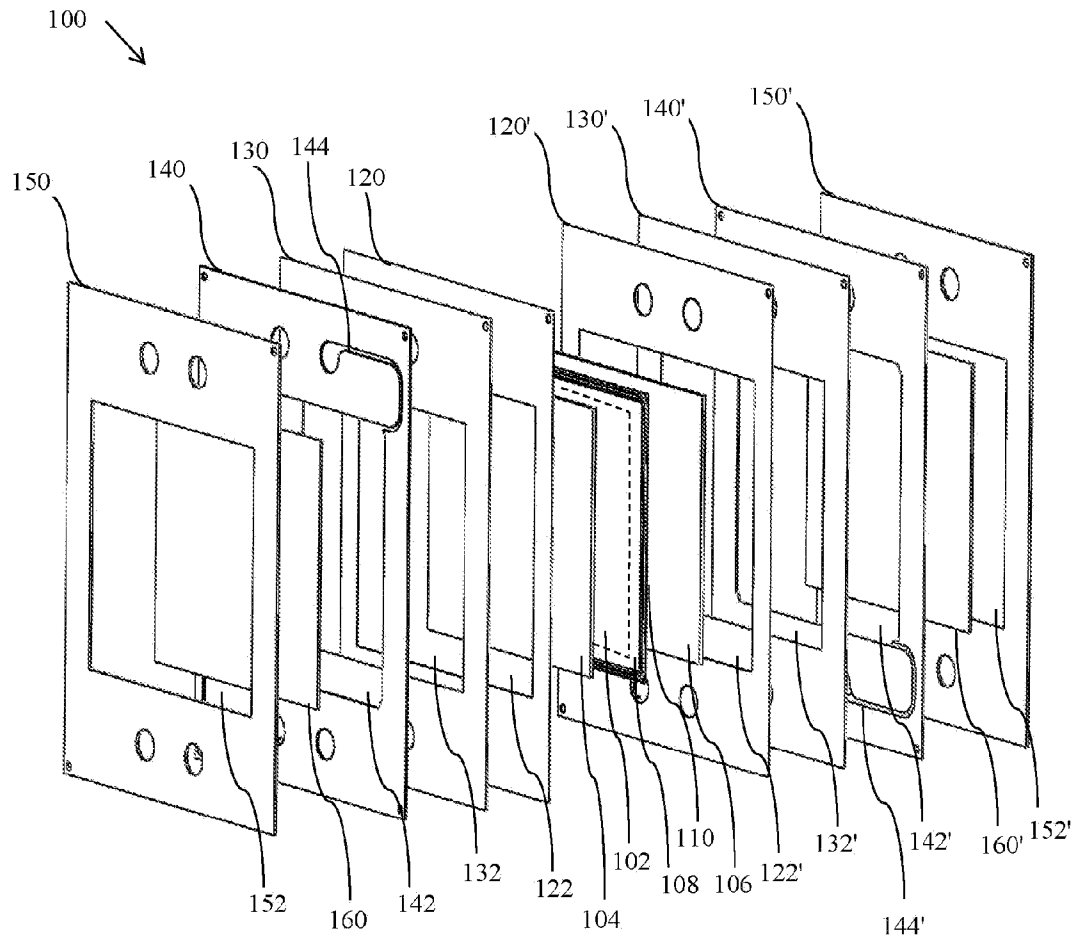

FIGURE 2

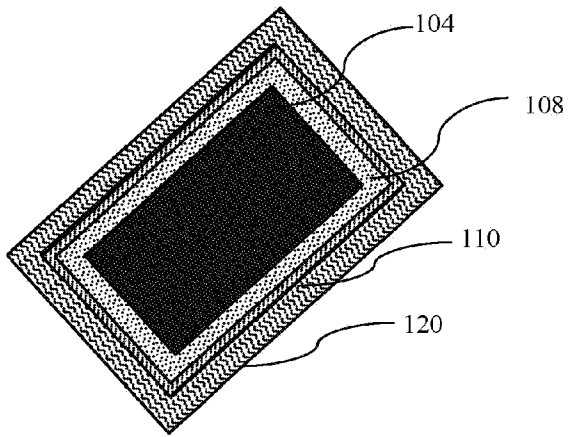

FIGURE 3A

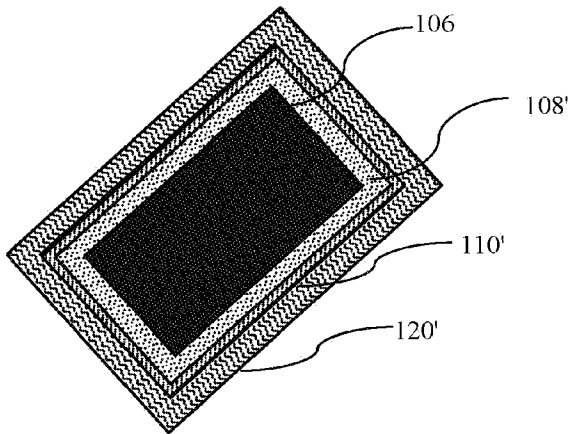

FIGURE 3B

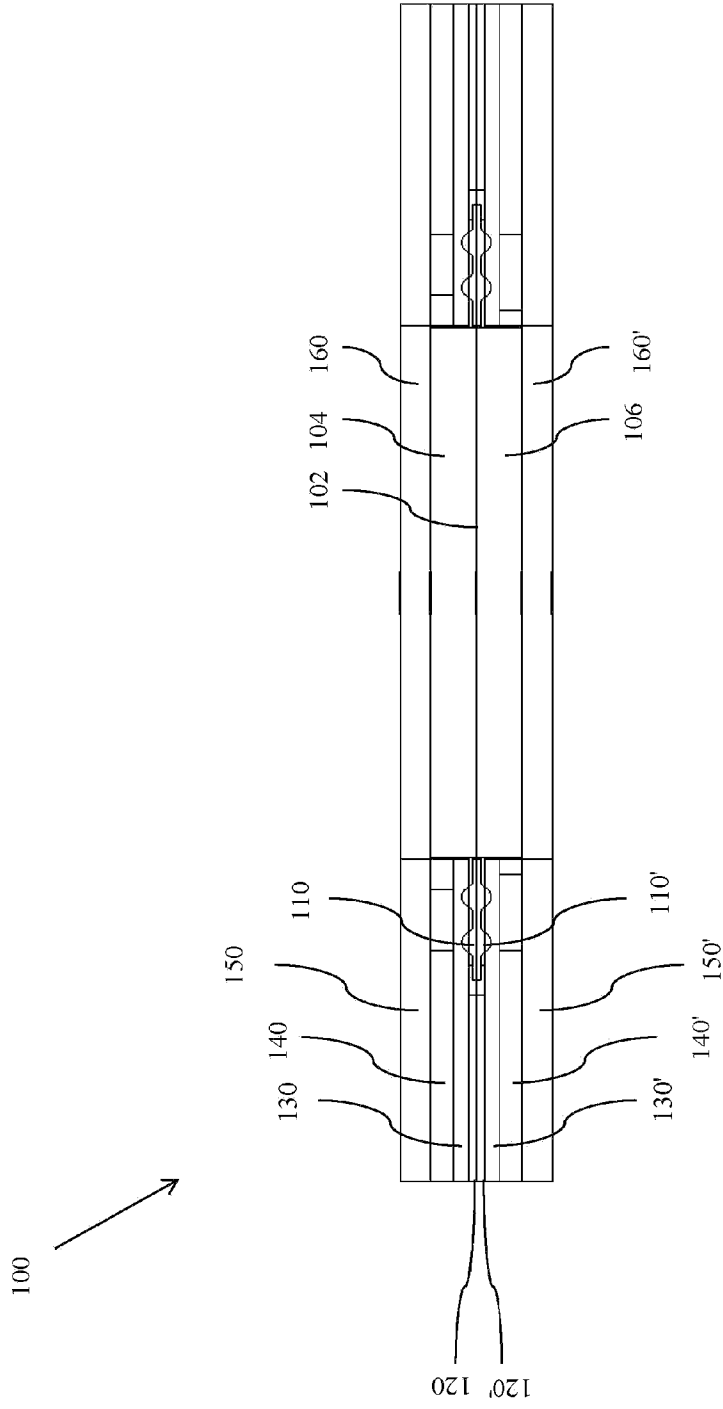

FIGURE 4

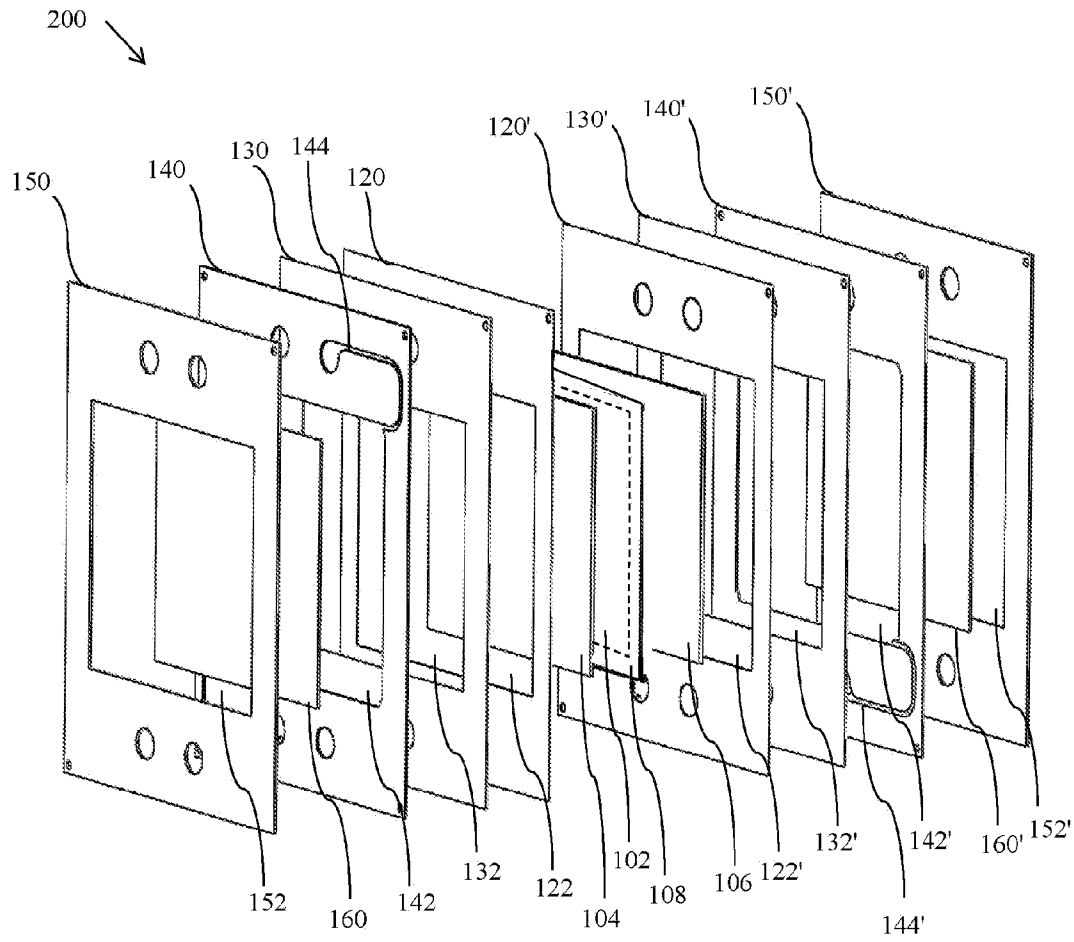

FIGURE 5

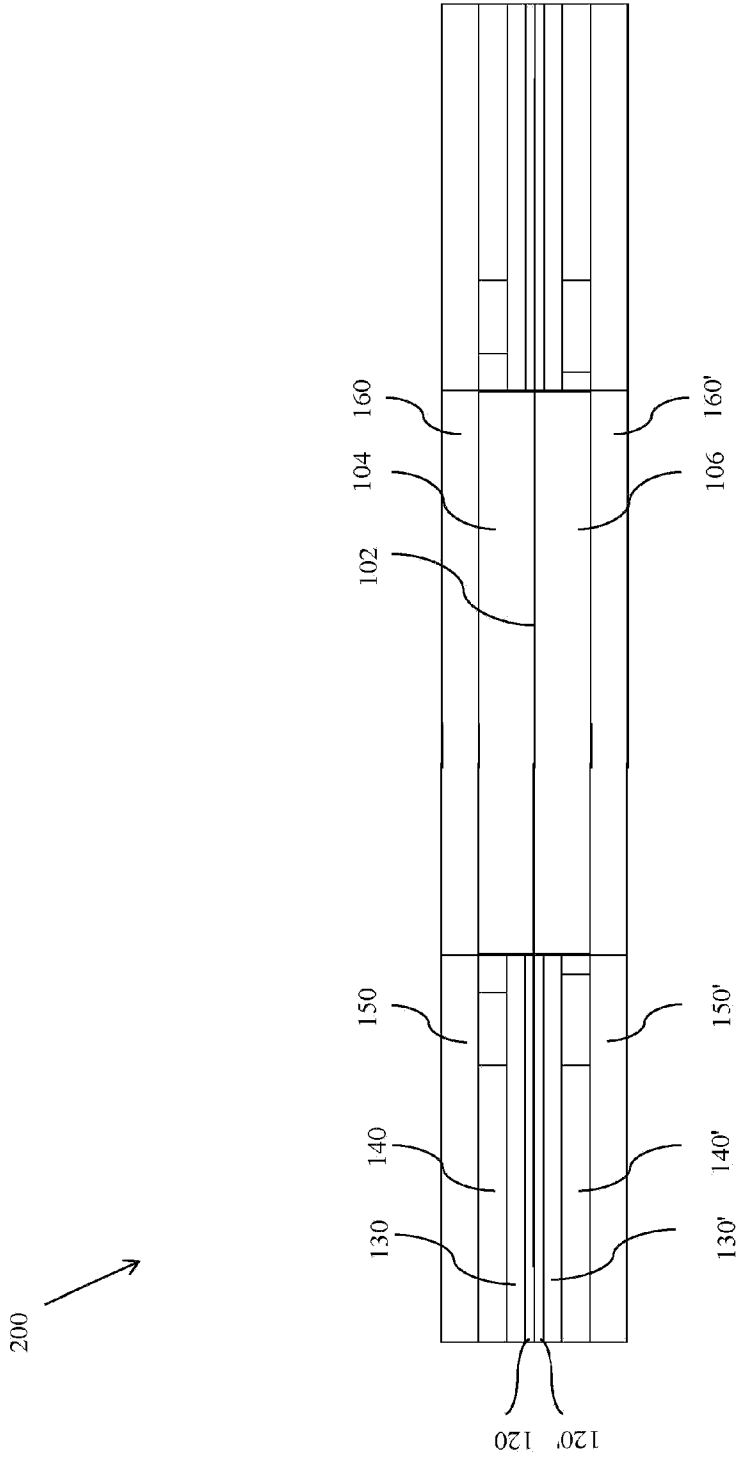

FIGURE 6

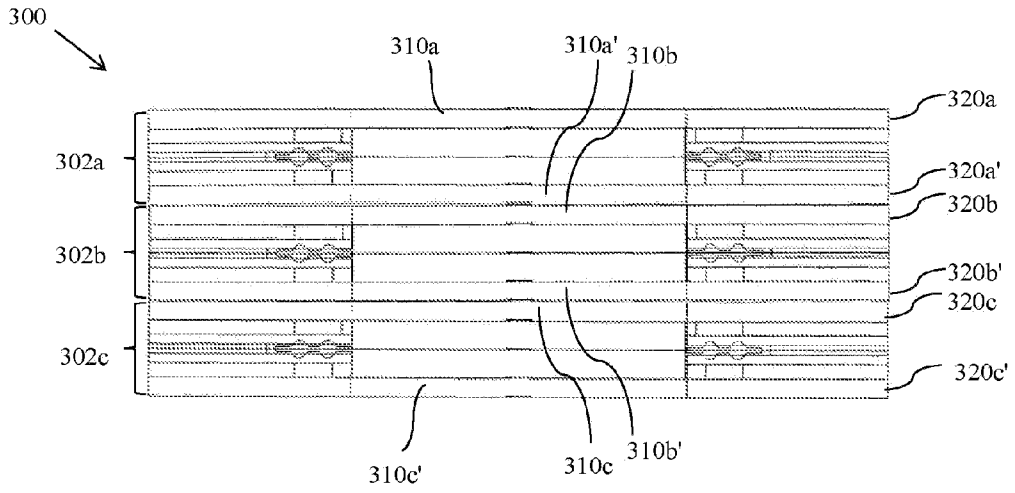

FIGURE 7

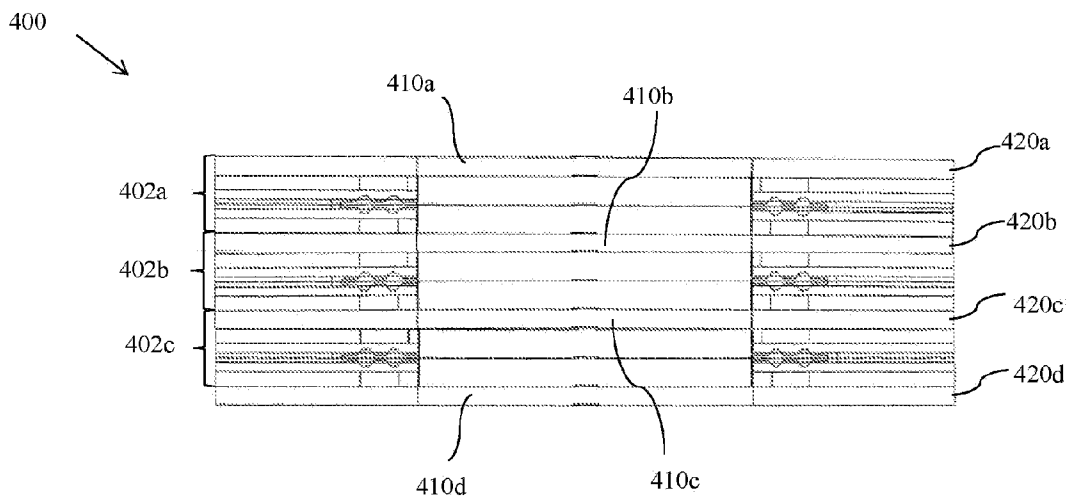

FIGURE 8

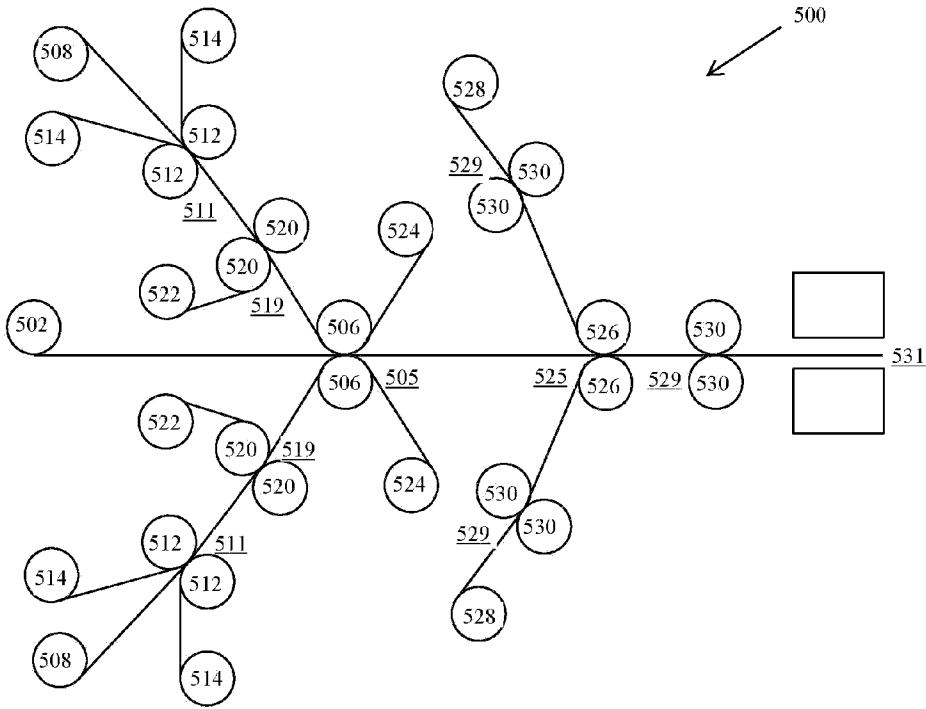

FIGURE 9

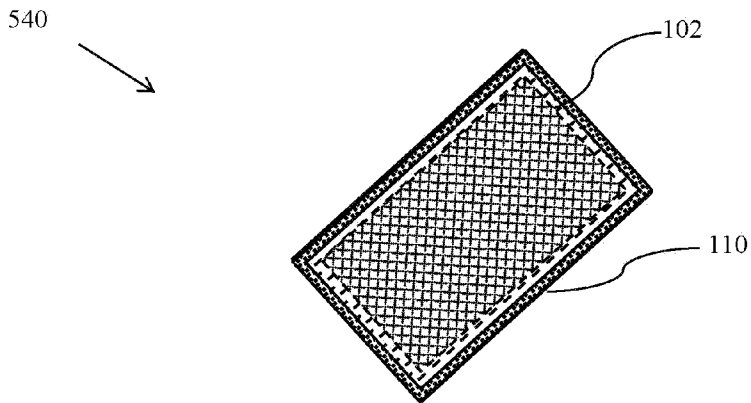

FIGURE 10A

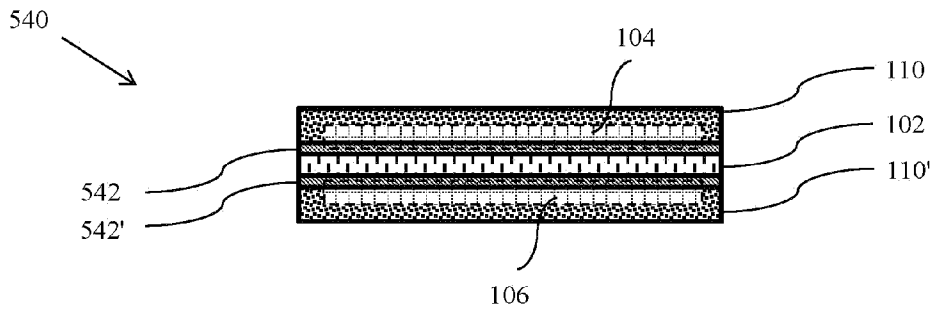

FIGURE 10B

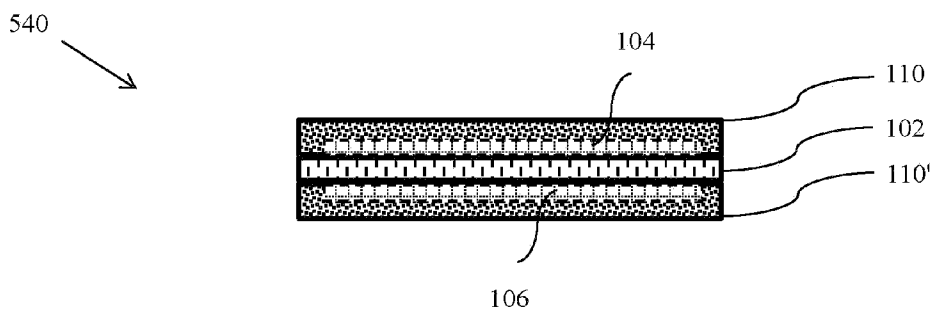

FIGURE 10C

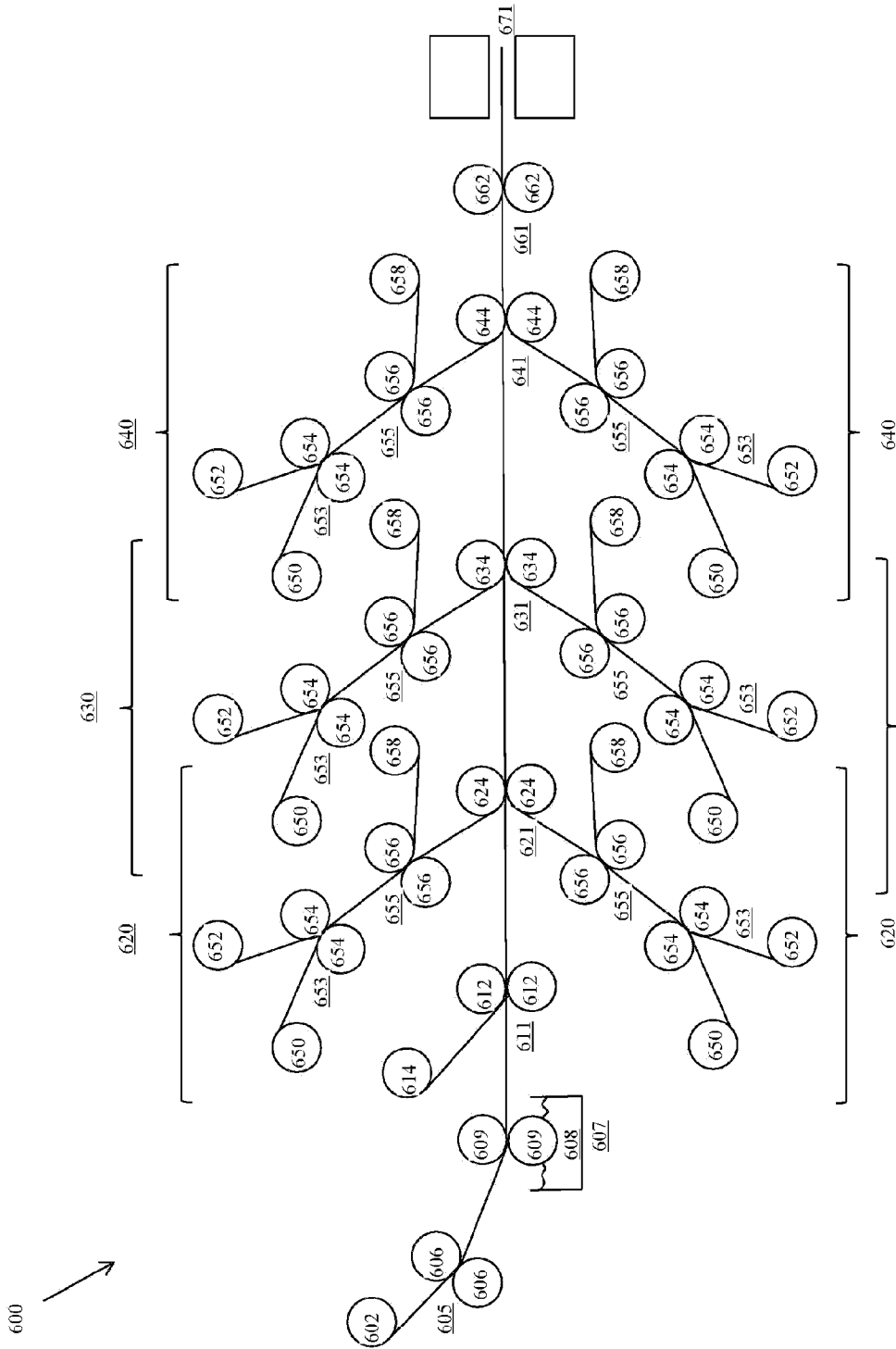

FIGURE 11

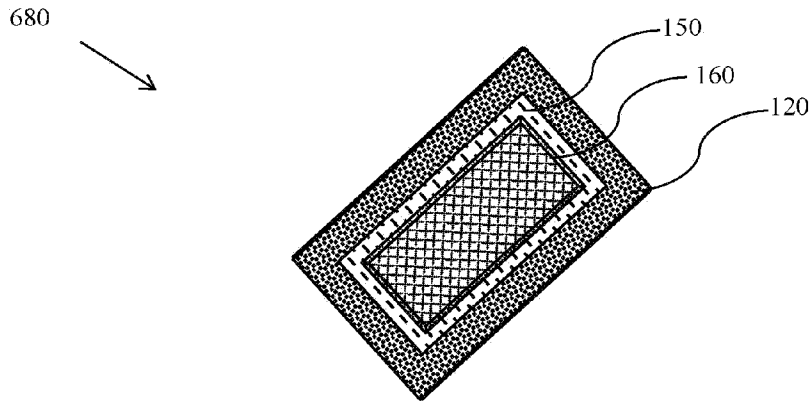

FIGURE 12A

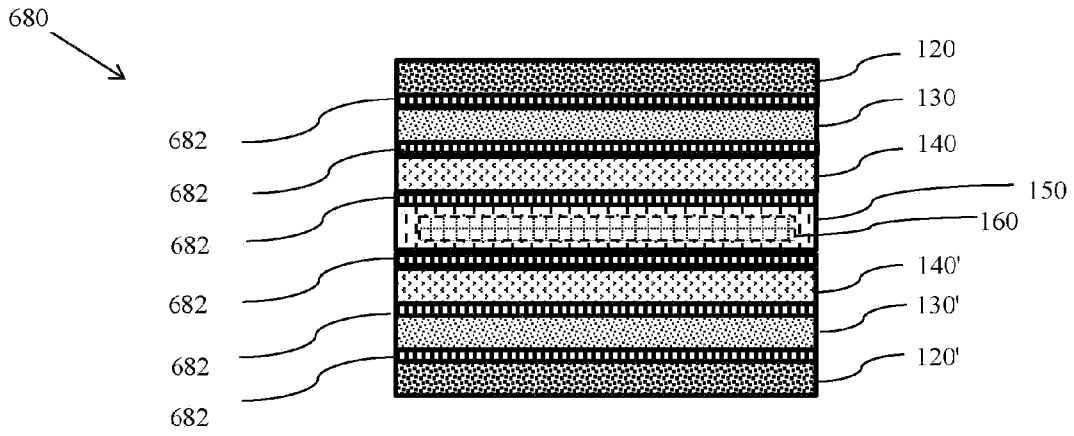

FIGURE 12B

680

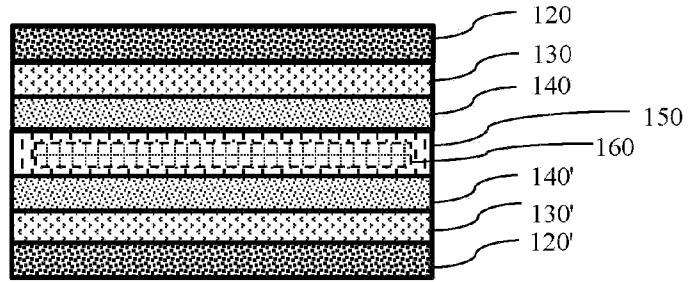

FIGURE 12C

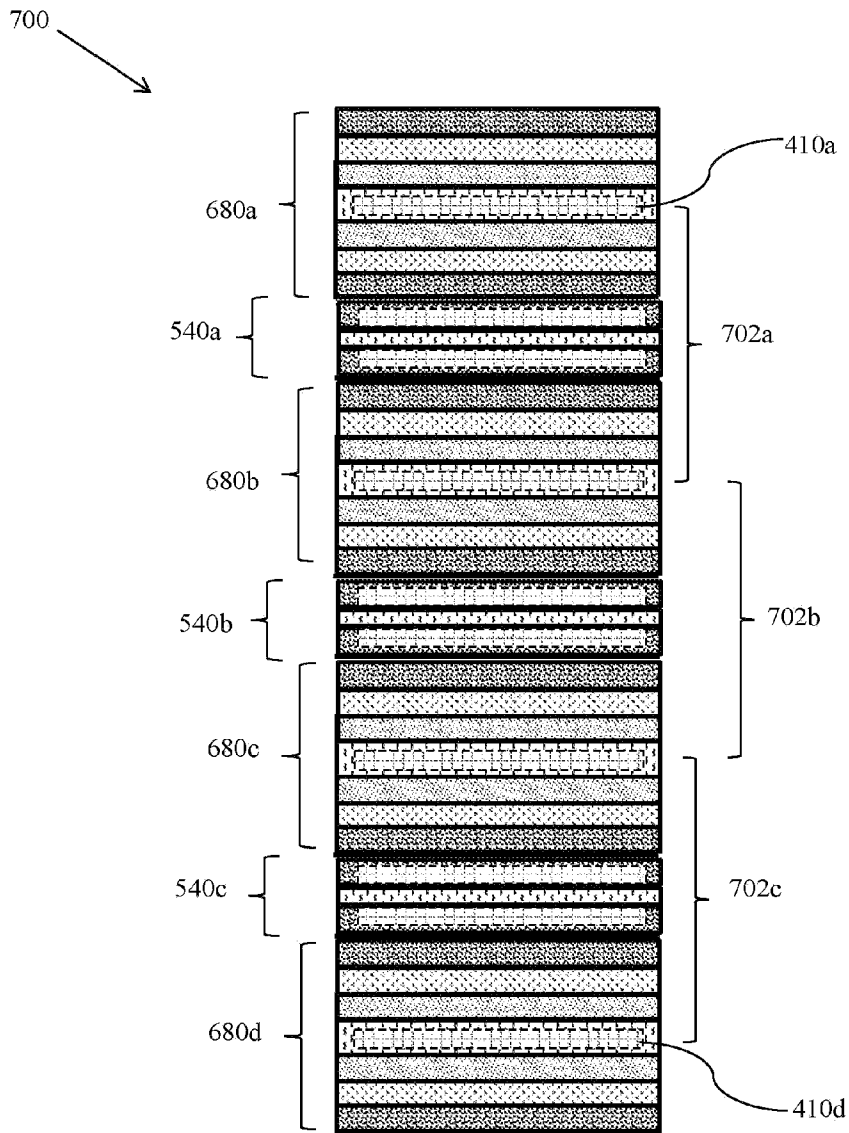

FIGURE 13

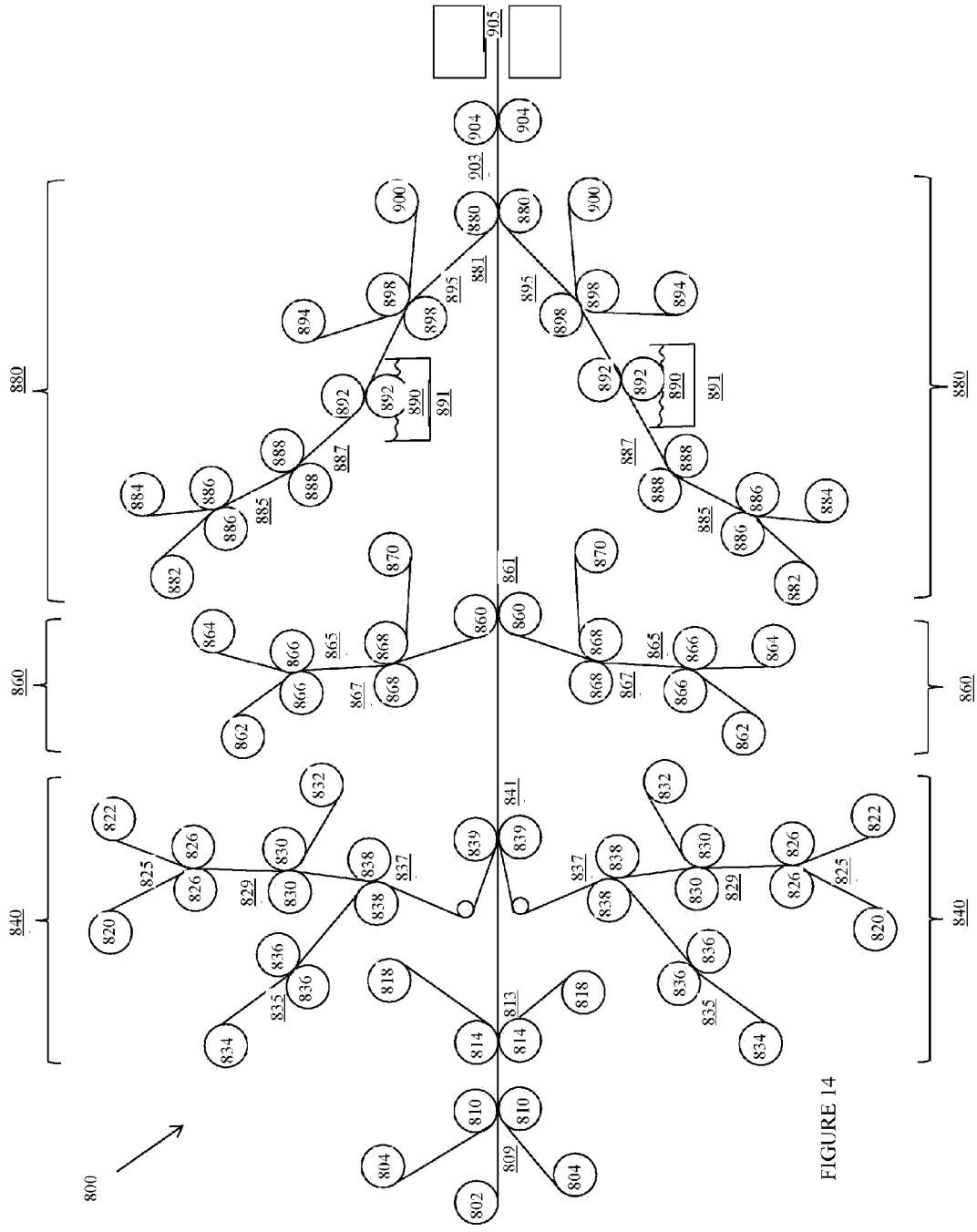

FIGURE 14