



US010444158B2

(12) **United States Patent**
Clark

(10) **Patent No.:** **US 10,444,158 B2**
(45) **Date of Patent:** ***Oct. 15, 2019**

(54) **ERROR MONITORING AND CORRECTION SYSTEMS AND METHODS IN AQUATIC ENVIRONMENT MONITORING**

(56) **References Cited**

U.S. PATENT DOCUMENTS

(71) Applicant: **Step Ahead Innovations, Inc.**, South Burlington, VT (US)

3,794,814 A 2/1974 Lay et al.
3,850,752 A 11/1974 Schuurs et al.
(Continued)

(72) Inventor: **James E. Clark**, South Burlington, VT (US)

FOREIGN PATENT DOCUMENTS

(73) Assignee: **Step Ahead Innovations, Inc.**, South Burlington, VT (US)

DE 19844500 A1 3/2000
EP 1182445 A2 2/2002
(Continued)

(*) Notice: Subject to any disclaimer, the term of this patent is extended or adjusted under 35 U.S.C. 154(b) by 232 days.

OTHER PUBLICATIONS

This patent is subject to a terminal disclaimer.

Photonic BioSystems. Oxygen Sensing Overview. <http://www.photonicssystems.com/oxygen.html>. Accessed on Jul. 12, 2012.

(Continued)

(21) Appl. No.: **15/445,453**

Primary Examiner — Krishnan S Menon

(22) Filed: **Feb. 28, 2017**

Assistant Examiner — Dwan A Gerido

(65) **Prior Publication Data**

(74) *Attorney, Agent, or Firm* — Birch Tree IP Law & Strategy PLLC; Jamie T. Gallagher

US 2017/0176339 A1 Jun. 22, 2017

Related U.S. Application Data

(57) **ABSTRACT**

(63) Continuation of application No. 13/713,568, filed on Dec. 13, 2012, now abandoned, which is a (Continued)

Systems, methods, and software that measure a plurality of error values each related to a different condition of an aquatic environment monitoring system including a degradation in a chemical indicator due to photo-aging, a degradation in a chemical indicator due to water-aging, a physical contamination of a chemical indicator, an illumination imbalance related to an optical reader, a degradation of a light source of an optical reader, a contamination in water between an optical reader and a chemical indicator, a displacement due to friction between a chemical indicator apparatus and a monitoring unit, an error intrinsic in a chemical indicator, and an error in distance between a chemical indicator and an optical reader. The plurality of error values are used to determine a confidence level that is compared to a threshold value associated with the monitoring system. A correction instruction is generated for correcting one or more of the conditions.

(51) **Int. Cl.**
G01N 21/77 (2006.01)
G01N 33/18 (2006.01)
(Continued)

(52) **U.S. Cl.**
CPC **G01N 21/77** (2013.01); **C02F 1/008** (2013.01); **G01N 21/15** (2013.01); **G01N 21/78** (2013.01);
(Continued)

(58) **Field of Classification Search**
CPC G01N 21/77; G01N 21/15; G01N 21/78
See application file for complete search history.

37 Claims, 28 Drawing Sheets

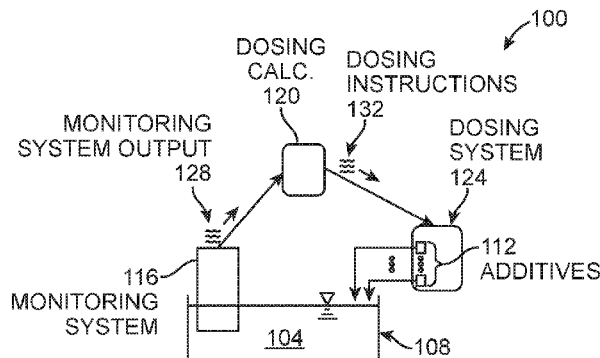

Related U.S. Application Data

- continuation of application No. PCT/US2012/069209, filed on Dec. 12, 2012.
- (60) Provisional application No. 61/630,450, filed on Dec. 12, 2011.
- (51) **Int. Cl.**
C02F 1/00 (2006.01)
G01N 21/85 (2006.01)
G01N 21/15 (2006.01)
G01N 21/88 (2006.01)
F21V 8/00 (2006.01)
G01N 21/78 (2006.01)
G01N 31/22 (2006.01)
A01K 63/04 (2006.01)
G01N 21/64 (2006.01)
C02F 103/42 (2006.01)
G01N 21/75 (2006.01)
- (52) **U.S. Cl.**
 CPC *G01N 21/8507* (2013.01); *G01N 21/88* (2013.01); *G01N 31/22* (2013.01); *G01N 33/18* (2013.01); *G02B 6/0001* (2013.01); *A01K 63/04* (2013.01); *C02F 2103/42* (2013.01); *C02F 2209/005* (2013.01); *C02F 2209/006* (2013.01); *C02F 2209/008* (2013.01); *C02F 2209/06* (2013.01); *C02F 2209/14* (2013.01); *C02F 2209/15* (2013.01); *C02F 2209/18* (2013.01); *G01N 21/6428* (2013.01); *G01N 2021/758* (2013.01); *G01N 2021/7786* (2013.01); *G01N 2021/7793* (2013.01); *G01N 2201/127* (2013.01); *Y10S 436/805* (2013.01); *Y10S 436/809* (2013.01); *Y10T 436/11* (2015.01); *Y10T 436/115831* (2015.01); *Y10T 436/12* (2015.01); *Y10T 436/173076* (2015.01); *Y10T 436/173845* (2015.01); *Y10T 436/174614* (2015.01); *Y10T 436/175383* (2015.01); *Y10T 436/193333* (2015.01); *Y10T 436/207497* (2015.01); *Y10T 436/25* (2015.01); *Y10T 436/25375* (2015.01)

5,837,546	A	11/1998	Allen et al.	
5,895,565	A	4/1999	Steininger et al.	
5,902,749	A	5/1999	Lichtwardt et al.	
5,952,491	A	9/1999	Leiner et al.	
5,958,782	A	9/1999	Bentsen et al.	
5,976,888	A	11/1999	Lee et al.	
5,994,150	A	11/1999	Challener et al.	
6,002,475	A	12/1999	Boyd et al.	
6,028,830	A	2/2000	Fritsch et al.	
6,051,437	A *	4/2000	Luo	B82Y 15/00 436/172
6,113,858	A	9/2000	Tang et al.	
6,124,135	A	9/2000	Leiner et al.	
6,171,866	B1	1/2001	He et al.	
6,187,530	B1	2/2001	Scholin et al.	
6,211,359	B1	4/2001	He et al.	
6,277,653	B1	8/2001	Challener et al.	
6,304,766	B1	10/2001	Colvin, Jr.	
6,332,110	B1	12/2001	Wolfe	
6,340,431	B2	1/2002	Khan	
6,342,349	B1	1/2002	Virtanen	
6,360,182	B1	3/2002	Hales	
6,441,055	B1	8/2002	Katerkamp et al.	
6,535,795	B1	3/2003	Schroeder et al.	
6,553,319	B1	4/2003	Helffrich et al.	
6,560,543	B2	5/2003	Wolfe et al.	
6,576,474	B2	6/2003	Wallach	
6,599,748	B1	7/2003	Nakajima et al.	
6,625,824	B1	9/2003	Lutz et al.	
6,635,439	B2	10/2003	Morrison et al.	
6,653,152	B2	11/2003	Challener	
6,657,546	B2	12/2003	Navarro et al.	
6,707,554	B1	3/2004	Miltner et al.	
6,756,014	B2	6/2004	Himmelhaus et al.	
6,794,191	B2	9/2004	Putnam et al.	
6,839,636	B1	1/2005	Sunshine et al.	
6,847,451	B2	1/2005	Pugh	
6,954,701	B2	10/2005	Wolfe	
7,014,612	B2	3/2006	Hubbard et al.	
7,040,157	B2	5/2006	Glasgow, Jr. et al.	
7,167,087	B2	1/2007	Corrington et al.	
7,222,047	B2	5/2007	McMillan et al.	
7,242,001	B1 *	7/2007	Hedges	G01N 21/25 250/343
7,283,245	B2	10/2007	Xiao et al.	
7,360,402	B2	4/2008	Liao	
7,378,954	B2	5/2008	Wendt	
7,385,497	B2	6/2008	Golden	
7,390,399	B2	6/2008	Dennis, II et al.	
7,391,333	B2	6/2008	Madden et al.	
7,393,188	B2	7/2008	Lawyer et al.	
7,454,295	B2	11/2008	Wolfe	
7,491,546	B2	2/2009	Jaunakais	
7,569,186	B2	8/2009	Bedingham et al.	
7,592,184	B2	9/2009	Khalil et al.	
7,601,544	B2	10/2009	Rehm	
7,720,615	B2	5/2010	Kim	
7,790,113	B2	9/2010	Putnam et al.	
7,858,383	B2	12/2010	He et al.	
7,862,770	B2	1/2011	Shahriari	
7,897,109	B2	3/2011	Labuda et al.	
7,905,245	B2	3/2011	McQuade et al.	
7,910,361	B2	3/2011	Barnes et al.	
7,924,927	B1	4/2011	Boesjes	
7,960,181	B2	6/2011	He et al.	
8,038,937	B2	10/2011	Kelly et al.	
8,038,947	B2	10/2011	Thompson	
8,062,221	B2	11/2011	Debreczeny et al.	
8,065,023	B2	11/2011	Graves	
8,069,706	B2	12/2011	Battefeld et al.	
8,097,725	B2	1/2012	He et al.	
8,125,331	B2	2/2012	Allen et al.	
8,145,431	B2	3/2012	Kloepfer et al.	
8,158,259	B2	4/2012	Ramamurthy et al.	
8,173,438	B1	5/2012	Putnam et al.	
8,202,503	B2	6/2012	Putnam et al.	
8,237,920	B2	8/2012	Jones et al.	
8,302,346	B2	11/2012	Hunt et al.	
8,455,844	B2	6/2013	Lear et al.	

(56) **References Cited**

U.S. PATENT DOCUMENTS

3,964,831	A	6/1976	Frank
4,033,871	A	7/1977	Wall
4,138,669	A	2/1979	Edison et al.
4,205,043	A	5/1980	Esch et al.
4,418,037	A	11/1983	Katsuyama et al.
4,577,109	A	3/1986	Hirschfeld
4,652,137	A	3/1987	Calzi
4,743,558	A	5/1988	Guigan
4,785,814	A	11/1988	Kane
4,814,144	A	3/1989	Edelmann et al.
4,898,832	A	2/1990	Klose et al.
5,061,381	A	10/1991	Burd
5,110,724	A	5/1992	Hewett
5,122,284	A	6/1992	Braynin et al.
5,173,193	A	12/1992	Schembri
5,176,882	A	1/1993	Gray et al.
5,304,348	A	4/1994	Burd et al.
5,350,694	A	9/1994	Zimmerle
5,411,889	A	5/1995	Hoots et al.
5,504,714	A	4/1996	Shonting
5,508,200	A	4/1996	Tiffany et al.
5,511,547	A	4/1996	Markle et al.
5,547,578	A	8/1996	Nielsen
5,623,561	A	4/1997	Hartman
5,824,270	A	10/1998	Rao

(56)

References Cited

U.S. PATENT DOCUMENTS

8,510,064 B2 8/2013 Streppel et al.
 8,515,880 B2 8/2013 Holley et al.
 8,534,228 B2 9/2013 Sudkamp
 8,577,623 B2 11/2013 Wolfe
 8,586,911 B2 11/2013 Micinski et al.
 8,734,734 B2 5/2014 Kido et al.
 8,797,523 B2 8/2014 Clark
 8,828,728 B2* 9/2014 Clark G01N 21/77
 436/50
 8,883,079 B2 11/2014 Clark
 8,968,681 B2 3/2015 Putnam et al.
 9,023,281 B2 5/2015 Clark
 9,080,985 B2 7/2015 Stevenson et al.
 9,261,462 B2 2/2016 Clark
 9,429,553 B2 8/2016 Jaunakais et al.
 9,494,526 B2 11/2016 Clark
 9,494,527 B2 11/2016 Clark
 9,784,686 B2 10/2017 Clark
 9,797,844 B2 10/2017 Clark
 2001/0031503 A1 10/2001 Challener
 2002/0054288 A1 5/2002 Kim et al.
 2002/0077777 A1 6/2002 Wolfe et al.
 2002/0117430 A1 8/2002 Navarro et al.
 2002/0119508 A1 8/2002 Morrison et al.
 2002/0123155 A1 9/2002 Himmelhaus et al.
 2002/0132363 A1 9/2002 Rehm
 2003/0003589 A1 1/2003 Khalil et al.
 2003/0003593 A1 1/2003 Wallach
 2003/0008400 A1 1/2003 Putnam et al.
 2003/0037602 A1 2/2003 Glasgow, Jr. et al.
 2003/0206302 A1 11/2003 Pugh
 2004/0006513 A1 1/2004 Wolfe
 2004/0013570 A1 1/2004 Labuda et al.
 2004/0077965 A1 4/2004 Hubbard et al.
 2004/0109853 A1 6/2004 McDaniel
 2004/0138840 A1 7/2004 Wolfe
 2004/0197922 A1 10/2004 Cooper
 2004/0224351 A1 11/2004 Shinohara
 2005/0112772 A1 5/2005 Farone et al.
 2005/0157304 A1 7/2005 Xiao et al.
 2005/0172910 A1* 8/2005 McMillan A01K 63/04
 119/226
 2005/0180890 A1 8/2005 Bedingham et al.
 2005/0214161 A1 9/2005 Gupta
 2006/0051874 A1 3/2006 Reed et al.
 2006/0073603 A1 4/2006 Jaunakais
 2006/0092008 A1 5/2006 Corrington et al.
 2006/0121623 A1 6/2006 He et al.
 2006/0131245 A1 6/2006 Dennis, II et al.
 2006/0210412 A1 9/2006 Lawyer et al.
 2006/0222567 A1 10/2006 Kloepfer et al.
 2006/0240573 A1 10/2006 Kao et al.
 2006/0278093 A1 12/2006 Biderman et al.
 2007/0039379 A1 2/2007 Liao
 2007/0074758 A1 4/2007 McQuade et al.
 2007/0078307 A1 4/2007 Debreczeny et al.
 2007/0233397 A1 10/2007 Kim
 2007/0241261 A1 10/2007 Wendt
 2007/0241881 A1 10/2007 Golden
 2007/0251461 A1 11/2007 Reichard et al.
 2007/0257806 A1 11/2007 Madden et al.
 2007/0259438 A1 11/2007 He et al.
 2007/0259443 A1 11/2007 He et al.
 2007/0259444 A1 11/2007 He et al.
 2008/0012577 A1 1/2008 Potyrailo et al.
 2008/0076184 A1 3/2008 Putnam et al.
 2008/0152864 A1 6/2008 Ramamurthy et al.
 2008/0160502 A1 7/2008 Barnes et al.
 2008/0254544 A1 10/2008 Modzelewski et al.
 2009/0004747 A1 1/2009 Agree et al.
 2009/0028756 A1 1/2009 Shahriari
 2009/0041621 A1 2/2009 Kelly et al.
 2009/0042311 A1 2/2009 Thompson
 2009/0098022 A1 4/2009 Tokhtuev et al.
 2009/0139456 A1 6/2009 Lin

2009/0215183 A1 8/2009 Takehara et al.
 2009/0301175 A1 12/2009 Battefeld et al.
 2010/0024526 A1 2/2010 Colvin, Jr. et al.
 2010/0052892 A1 3/2010 Allen et al.
 2010/0069891 A1 3/2010 Ginggen
 2010/0099193 A1* 4/2010 Hsu G01N 33/18
 436/47
 2010/0129852 A1 5/2010 Putnam et al.
 2010/0133175 A1 6/2010 Putnam et al.
 2010/0136608 A1 6/2010 Putnam et al.
 2010/0146587 A1 6/2010 Sholes et al.
 2010/0187185 A1 7/2010 Johnson et al.
 2010/0228505 A1 9/2010 Streppel et al.
 2010/0230614 A1 9/2010 Lear et al.
 2010/0265509 A1 10/2010 Jones et al.
 2010/0280773 A1 11/2010 Saether
 2010/0330692 A1 12/2010 Khalil et al.
 2010/0332149 A1 12/2010 Scholpp
 2011/0071966 A1 3/2011 Holley et al.
 2011/0081728 A1 4/2011 Putnam et al.
 2011/0086359 A1 4/2011 Babu et al.
 2011/0168609 A1 7/2011 McQuade et al.
 2011/0179706 A1 7/2011 Hunt et al.
 2011/0198487 A1 8/2011 Micinski et al.
 2011/0218655 A1 9/2011 Graves
 2011/0290007 A1 12/2011 Sudkamp
 2011/0299130 A1 12/2011 Ito
 2012/0092131 A1 4/2012 Vasic et al.
 2012/0116683 A1 5/2012 Potyrailo et al.
 2012/0183984 A1 7/2012 He et al.
 2013/0009781 A1 1/2013 Wolfe
 2013/0013259 A1 1/2013 Wolfe
 2013/0168327 A1 7/2013 Clark
 2013/0330245 A1 12/2013 Duncan et al.
 2014/0000507 A1 1/2014 Clark
 2014/0000651 A1 1/2014 Clark
 2014/0001126 A1 1/2014 Clark
 2014/0016122 A1 1/2014 Clark
 2014/0016344 A1 1/2014 Clark
 2014/0017143 A1 1/2014 Clark
 2014/0017796 A1 1/2014 Clark
 2014/0017801 A1 1/2014 Clark
 2014/0019060 A1 1/2014 Clark
 2014/0019069 A1 1/2014 Clark
 2014/0072474 A1 3/2014 Kido et al.
 2014/0107939 A1 4/2014 Jaunakais et al.
 2014/0134052 A1 5/2014 Stevenson et al.
 2016/0091431 A1 3/2016 Clark
 2016/0091432 A1 3/2016 Clark
 2016/0116418 A1 4/2016 Clark
 2016/0200601 A1 7/2016 Clark

FOREIGN PATENT DOCUMENTS

EP 852715 B1 5/2002
 EP 1217373 A1 6/2002
 EP 1225442 A2 7/2002
 EP 1359409 A2 11/2003
 EP 17189116.1 12/2017
 EP 17189116.1 7/2018
 GB 2480301 A 11/2011
 GB 2482155 A 1/2012
 WO 1993/007089 A1 4/1993
 WO 1996/028817 9/1996
 WO 1997/012225 4/1997
 WO 1999/018421 4/1999
 WO 2000/04367 1/2000
 WO 2000/019185 A1 4/2000
 WO 2000/42339 7/2000
 WO 2001/029541 A1 4/2001
 WO 2007/115321 A2 10/2007
 WO 2008/035231 A2 3/2008
 WO 2009/149580 A1 12/2009
 WO 2012/011074 A2 1/2012
 WO 2012/168703 A1 12/2012
 WO 2013/090407 A2 6/2013
 WO PCT/US2012/069209 6/2013

(56)

References Cited

FOREIGN PATENT DOCUMENTS

WO 2014/145337 A2 9/2014
 WO 2014/205230 A1 12/2014

OTHER PUBLICATIONS

Photonic BioSystems. Oxygen Sensing Features and Benefits. <http://www.photonicsystems.com/O2features.html>. Accessed on Jul. 12, 2012.

Photonic BioSystems. Oxygen Sensing Applications. <http://www.photonicsystems.com/O2applications.html>. Accessed on Jul. 12, 2012.

Sutron. DS5x Multiparameter Water Quality Sonde Datasheet. <http://www.sutron.com/documents/ds5x-multiparameter-water-quality-sonde-datasheet.pdf>. Accessed on Jul. 19, 2012.

Michael, Eric. EcoTech Marine Pump Patent Challenged: Request for Re-Examination Filed. GlassboxDesign.com. <http://glassbox-design.com/2011/ecotech-marine-patent-reexam/>. Sep. 4, 2011.

Pacific Sentry. Ammonia Detection Sensors/Monitors for Water Applications. <http://www.pacificsentry.com/water.html>. Accessed on Jul. 1, 2013.

Sutron. DS5x Multiparameter Water Quality Sonde Datasheet. Jun. 1, 2012.

Seneye. Retail Brochure for Aquatic Warning System. <http://www.seneye.com>. Accessed Jul. 11, 2012.

Gupta, B.D. et al. "A Long-Range Fiber Optic pH Sensor Prepared by Dye Doped Sol-Gel Immobilization Technique." *Optics Communications* 154 (1998) 282-284. Sep. 15, 1998.

Lamotte Spinlab Quick Guide. Dec. 10, 2012.

Lamotte Spinlab Announcement. <http://www.lamotte.com/component/option>. Feb. 2, 2012. Accessed using web.archive.org on Oct. 25, 2013.

Raghuraman, B. et al. "Spectroscopic pH Measurement for High Temperatures, Pressures and Ionic Strength." Wiley InterScience (www.interscience.wiley.com). Jul. 25, 2006.

Millero, F.J. "History of the equation of state of seawater." *Oceanography* 23(3):18-33, doi:10.5670/oceanog.2010.21. Sep. 2010.

Clayton, Tonya D. et al. "Spectrophotometric seawater pH measurements: total hydrogen ion concentration scale calibration of m-cresol purple and at-sea results." *Deep-Sea Research*, vol. 40, No. 10, pp. 2115-2129, 1993.

Millero, F.J. "Carbonate constants for estuarine waters." *Marine and Freshwater Research*, 2010, 61, 139-142. 2010.

Riddle, Dana. "Product Review: Inexpensive Analytical Devices: Hanna Instruments' Checkers: Alkalinity and Phosphate." *Advanced Aquarist*. <http://www.advancedaquarist.com/2011/8/review>. Aug. 2011. Accessed on May 28, 2017.

Hanna Checker Product Review. ReefAddicts. <http://www.reefaddicts.com/content.php/398-product-review-hanna-phosphate-checker>. Oct. 26, 2013. Accessed May 28, 2017.

"Flourescence Spectroscopy." Wikipedia.org. Dec. 5, 2011. Accessed at Internet Archive Wayback Machine on Jun. 2, 2017 (http://web.archive.org/web/20111205222128/https://en.wikipedia.org/wiki/Fluorescence_spectroscopy).

U.S. Appl. No. 13/713,495, Dec. 31, 2014, Notice of Allowance, U.S. Pat. No. 9,023,281.

U.S. Appl. No. 13/713,495, Jan. 6, 2015, Amendment After Notice of Allowance (Rule 312), U.S. Pat. No. 9,023,281.

U.S. Appl. No. 13/713,495, Jan. 20, 2015, Response to Amendment Under Rule 312, U.S. Pat. No. 9,023,281.

U.S. Appl. No. 13/713,537, Dec. 3, 2013, Office Action, U.S. Pat. No. 8,883,079.

U.S. Appl. No. 13/713,537, Apr. 3, 2014, Response to Office Action, U.S. Pat. No. 8,883,079.

U.S. Appl. No. 13/713,537, Jun. 30, 2014, Examiner Initiated Interview Summary, U.S. Pat. No. 8,883,079.

U.S. Appl. No. 13/713,537, Jun. 30, 2014, Notice of Allowance, U.S. Pat. No. 8,883,079.

U.S. Appl. No. 13/713,537, Jul. 10, 2014, Amendment After Notice of Allowance (Rule 312), U.S. Pat. No. 8,883,079.

U.S. Appl. No. 13/713,537, Oct. 22, 2014, Issue Notification, U.S. Pat. No. 8,883,079.

U.S. Appl. No. 13/713,568, May 29, 2015, Office Action.

U.S. Appl. No. 13/713,568, Aug. 31, 2015, Response to Office Action.

U.S. Appl. No. 13/713,568, Nov. 27, 2015, Office Action.

U.S. Appl. No. 13/713,568, Feb. 27, 2016, Response to Office Action.

U.S. Appl. No. 13/713,568, Aug. 18, 2016, Office Action (Final).

U.S. Appl. No. 13/713,568, Feb. 28, 2017, Petition to Revive.

U.S. Appl. No. 13/713,568, Mar. 3, 2017, Notice of Abandonment.

U.S. Appl. No. 13/713,568, Aug. 16, 2017, Petition Decision (Revival for Continuity).

U.S. Appl. No. 13/713,595, Jan. 16, 2015, Restriction Requirement, U.S. Pat. No. 9,494,526.

U.S. Appl. No. 13/713,595, Mar. 16, 2015, Response to Restriction Requirement, U.S. Pat. No. 9,494,526.

U.S. Appl. No. 13/713,595, Jun. 24, 2015, Office Action, U.S. Pat. No. 9,494,526.

U.S. Appl. No. 13/713,595, Nov. 23, 2015, Response to Office Action, U.S. Pat. No. 9,494,526.

U.S. Appl. No. 13/713,595, Mar. 3, 2016, Office Action (Final), U.S. Appl. No. 9,494,526.

U.S. Appl. No. 13/713,595, Jul. 4, 2016, Response to Office Action, U.S. Pat. No. 9,494,526.

U.S. Appl. No. 13/713,595, Jul. 21, 2016, Notice of Allowance, U.S. Pat. No. 9,494,526.

U.S. Appl. No. 13/713,714, Feb. 17, 2015, Office Action.

U.S. Appl. No. 13/713,714, May 28, 2015, Response to Office Action.

U.S. Appl. No. 13/713,714, Aug. 18, 2015, Final Office Action.

U.S. Appl. No. 13/713,714, Dec. 18, 2015, Response to Office Action.

U.S. Appl. No. 13/713,714, Jan. 12, 2016, Applicant Initiated Interview Summary.

U.S. Appl. No. 13/713,714, Feb. 9, 2016, Advisory Action.

U.S. Appl. No. 13/713,737, Jul. 20, 2015, Office Action.

U.S. Appl. No. 13/713,737, Dec. 21, 2015, Response to Office Action.

U.S. Appl. No. 13/713,737, Mar. 18, 2016, Office Action (Final).

U.S. Appl. No. 13/713,818, Jan. 24, 2014, Office Action.

U.S. Appl. No. 13/713,864, Mar. 7, 2016, Restriction Requirement, U.S. Pat. No. 9,494,527.

U.S. Appl. No. 13/713,864, May 9, 2016, Response to Restriction Requirement, U.S. Pat. No. 9,494,527.

U.S. Appl. No. 13/713,864, Jul. 11, 2016, Notice of Allowance, U.S. Pat. No. 9,494,527.

U.S. Appl. No. 14/959,063, Jun. 29, 2016, Office Action.

U.S. Appl. No. 14/959,063, Sep. 29, 2016, Response to Office Action.

U.S. Appl. No. 14/959,063, Nov. 3, 2016, Restriction Requirement.

U.S. Appl. No. 14/959,063, Jan. 3, 2017, Response to Restriction Requirement.

U.S. Appl. No. 14/959,063, Feb. 14, 2017, Notice of Allowance.

U.S. Appl. No. 14/959,063, May 15, 2017, Request for Continued Examination.

U.S. Appl. No. 14/959,063, Jun. 6, 2017, eTerminal Disclaimer.

U.S. Appl. No. 14/959,063, Jun. 16, 2017, Office Action.

U.S. Appl. No. 14/959,063, Nov. 16, 2017, Response to Office Action.

U.S. Appl. No. 14/959,063, Dec. 6, 2017, Office Action.

U.S. Appl. No. 14/959,063, May 7, 2018, Response to Office Action.

U.S. Appl. No. 14/959,063, May 23, 2018, Advisory Action.

U.S. Appl. No. 14/959,063, May 24, 2018, Interview Summary.

U.S. Appl. No. 14/959,063, Jun. 26, 2018, RCE, Response to Office Action, Petition to Revive.

U.S. Appl. No. 14/959,063, Aug. 30, 2018, Notice of Allowance.

U.S. Appl. No. 14/895,980, May 30, 2017, Terminal Disclaimer, U.S. Pat. No. 9,784,656.

(56)

References Cited

OTHER PUBLICATIONS

U.S. Appl. No. 14/895,980, Jun. 6, 2017, Notice of Allowance and Examiner Interview Summary, U.S. Pat. No. 9,784,656.
U.S. Appl. No. 14/895,980, Sep. 20, 2017, Issue Notification, U.S. Pat. No. 9,784,656.
U.S. Appl. No. 14/959,073, Jun. 2, 2017, Request for Continued Examination, U.S. Pat. No. 9,797,844.
U.S. Appl. No. 14/959,073, Jun. 2, 2017, Response to Office Action (Final), U.S. Pat. No. 9,797,844.
U.S. Appl. No. 14/959,073, Oct. 28, 2016, Office Action, U.S. Pat. No. 9,797,844.
U.S. Appl. No. 14/959,073, Jan. 30, 2017, Response to Office Action, U.S. Appl. No. 9,797,844.
U.S. Appl. No. 14/959,073, Mar. 2, 2017, Office Action (Final), U.S. Pat. No. 9,797,844.
U.S. Appl. No. 14/959,073, Jun. 21, 2017, Notice of Allowance, U.S. Pat. No. 9,797,844.
U.S. Appl. No. 14/959,073, Oct. 4, 2017, Issue Notification, U.S. Pat. No. 9,797,844.
U.S. Appl. No. 14/771,491, Jul. 9, 2018, Response to Office Action.
U.S. Appl. No. 14/771,491, Feb. 9, 2018, Office Action (2nd Nonfinal).
U.S. Appl. No. 14/771,491, Nov. 2, 2017, Response to Office Action.
U.S. Appl. No. 14/771,491, Aug. 2, 2017, Office Action.
U.S. Appl. No. 13/713,495, filed Dec. 13, 2013, U.S. Pat. No. 9,023,281.
U.S. Appl. No. 13/713,537, filed Dec. 13, 2013, U.S. Pat. No. 8,883,079.
U.S. Appl. No. 13/713,568, filed Dec. 13, 2013.
U.S. Appl. No. 13/713,595, filed Dec. 13, 2013, U.S. Pat. No. 9,494,526.

U.S. Appl. No. 13/713,714, filed Dec. 13, 2013.
U.S. Appl. No. 13/713,737, filed Dec. 13, 2013.
U.S. Appl. No. 13/713,818, filed Dec. 13, 2013.
U.S. Appl. No. 13/713,864, filed Dec. 13, 2013, U.S. Pat. No. 9,494,527.
U.S. Appl. No. 14/771,491, filed Aug. 29, 2015.
U.S. Appl. No. 14/895,980, filed Dec. 4, 2015, U.S. Pat. No. 9,784,686.
U.S. Appl. No. 14/959,063, filed Dec. 4, 2015.
U.S. Appl. No. 14/959,073, filed Dec. 4, 2015, U.S. Pat. No. 9,797,844.
U.S. Appl. No. 16/124,855, filed Sep. 7, 2018.
U.S. Appl. No. 13/713,629, Jan. 28, 2014, Office Action.
U.S. Appl. No. 13/713,629, Apr. 28, 2014, Response to Office Action.
U.S. Appl. No. 13/713,629, Jul. 10, 2014, Supplemental Amendment.
U.S. Appl. No. 13/713,629, Jul. 16, 2014, Notice of Allowance.
U.S. Appl. No. 13/713,629, Aug. 20, 2014, Issue Notification.
U.S. Appl. No. 13/713,668, May 22, 2014, Notice of Allowance.
U.S. Appl. No. 13/713,668, Jun. 24, 2014, Notice to File Corrected Application Papers (After Allowance).
U.S. Appl. No. 13/713,668, Jul. 1, 2014, Amendment After Notice of Allowance (Rule 312).
U.S. Appl. No. 13/713,668, Jul. 16, 2014, Issue Notification.
U.S. Appl. No. 13/713,773, Oct. 9, 2015, Notice of Allowance.
U.S. Appl. No. 13/713,773, Jan. 28, 2016, Issue Notification.
U.S. Appl. No. 13/713,629, filed Dec. 13, 2013, U.S. Pat. No. 8,828,728.
U.S. Appl. No. 13/713,668, filed Dec. 13, 2013, U.S. Pat. No. 8,797,523.
U.S. Appl. No. 13/713,773, filed Dec. 13, 2013, U.S. Pat. No. 9,261,462.

* cited by examiner

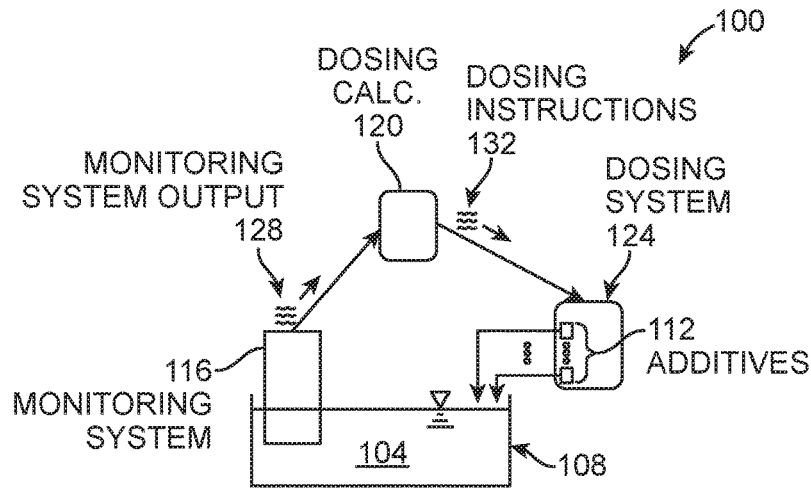

FIG. 1

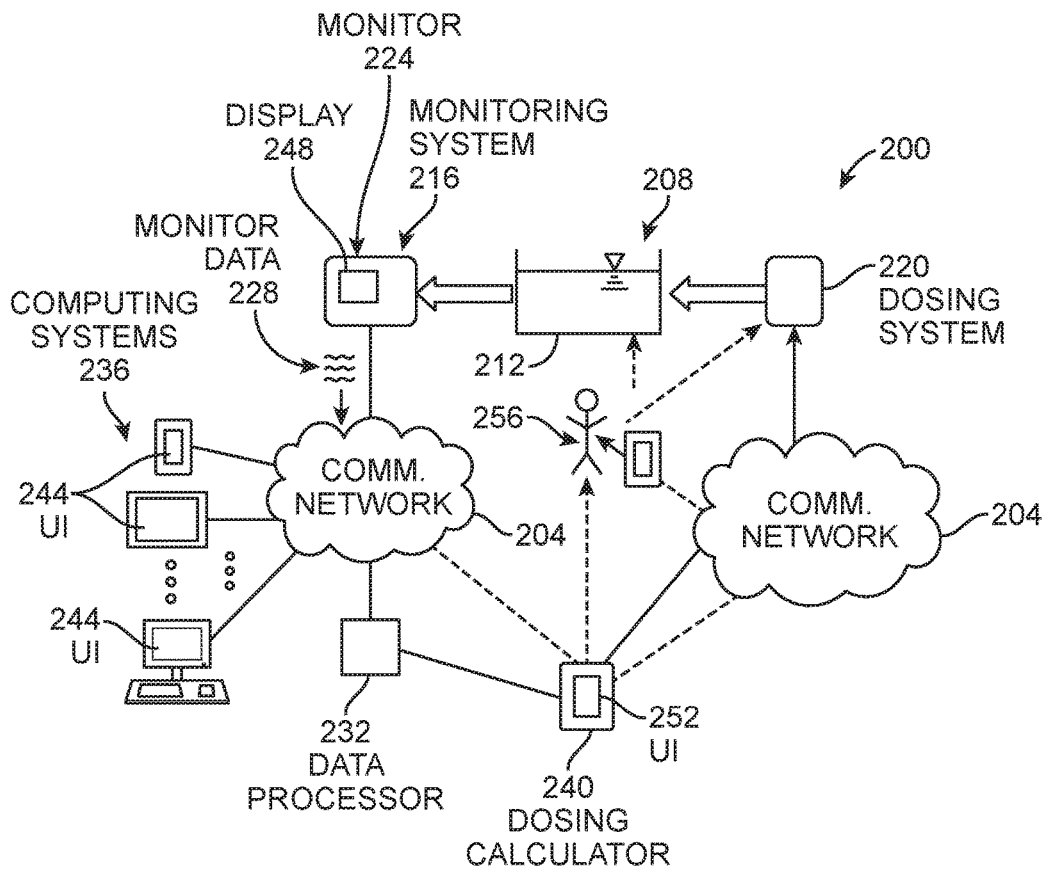

FIG. 2

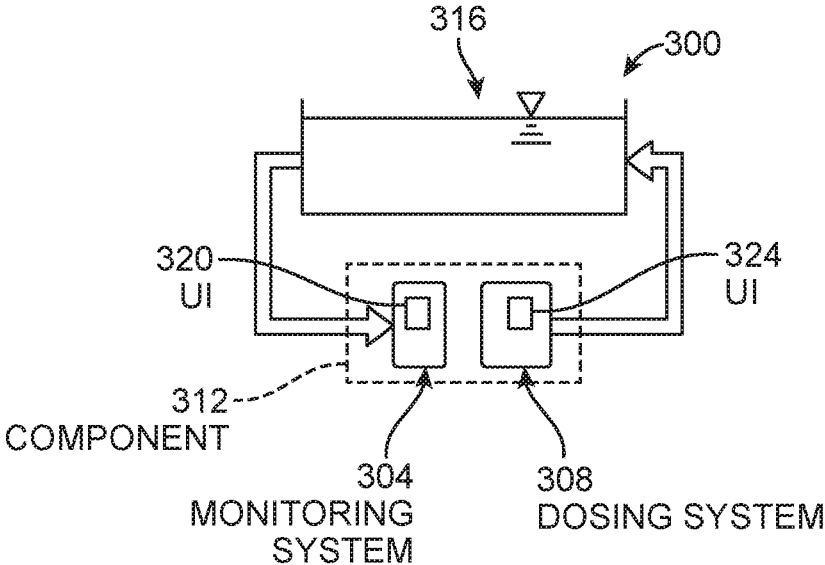

FIG. 3

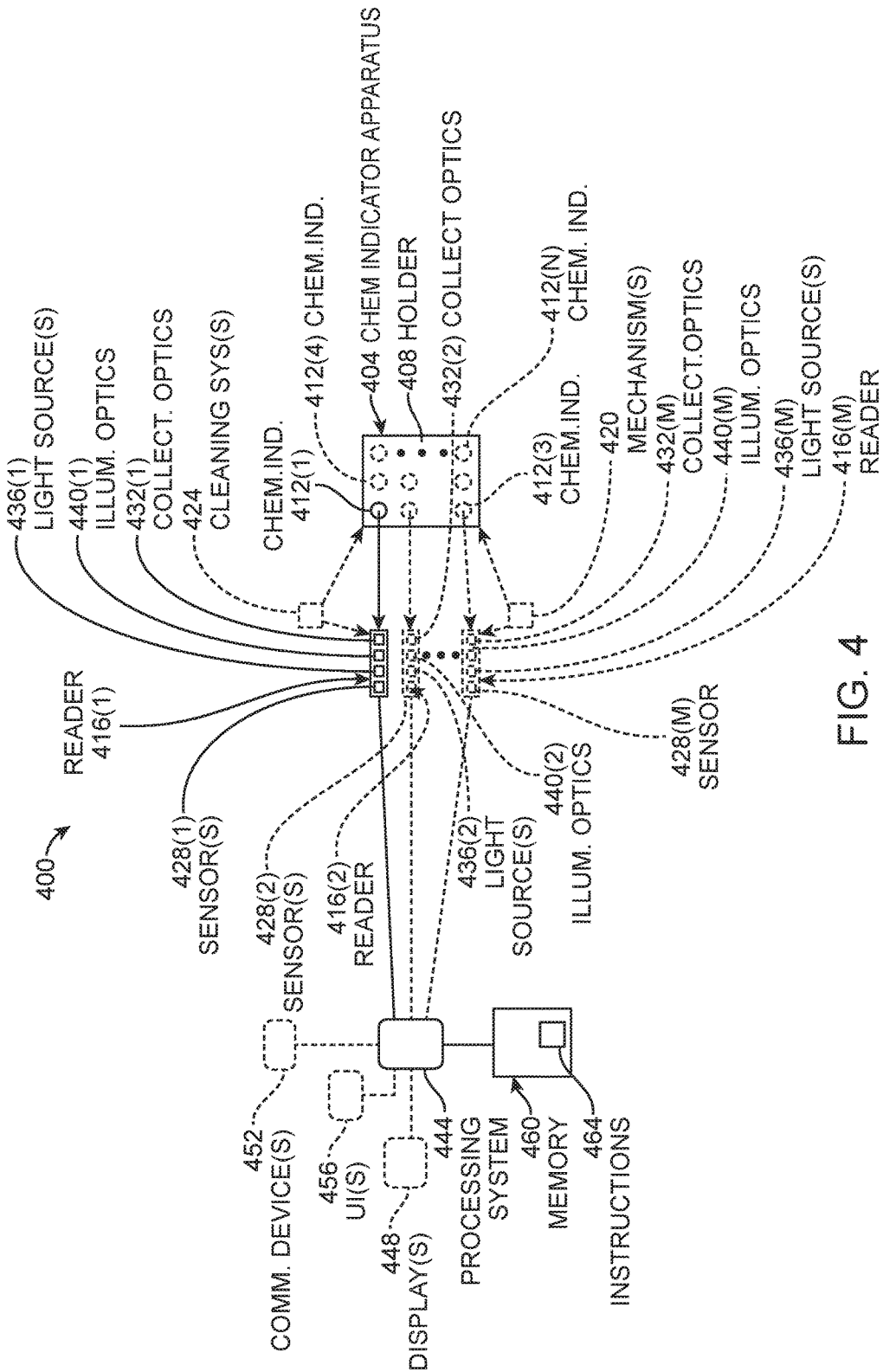

FIG. 4

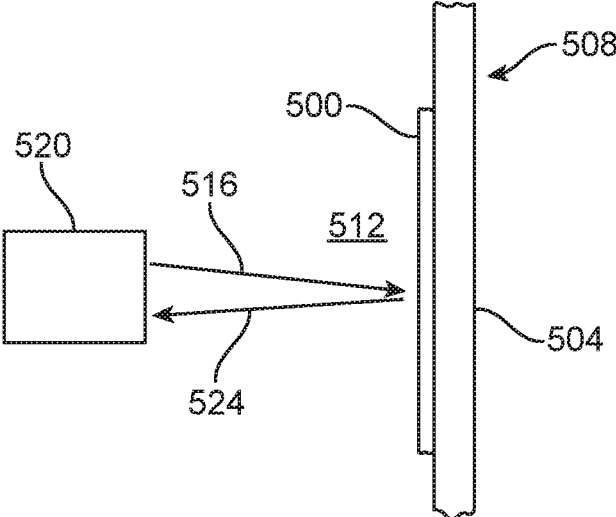

FIG. 5

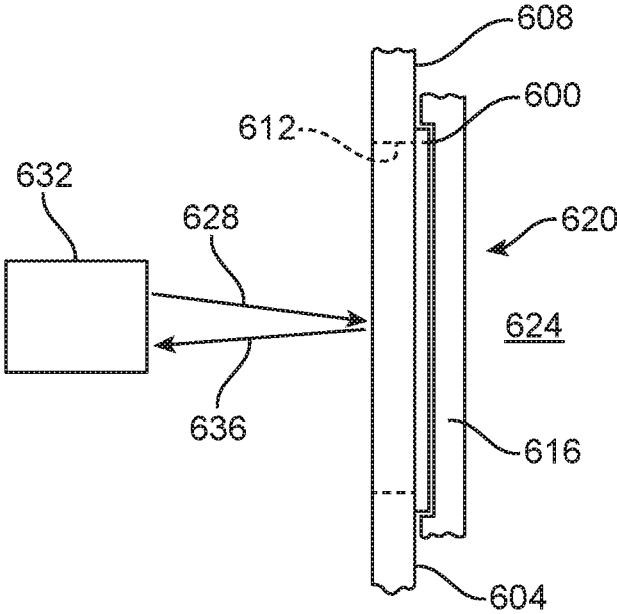

FIG. 6

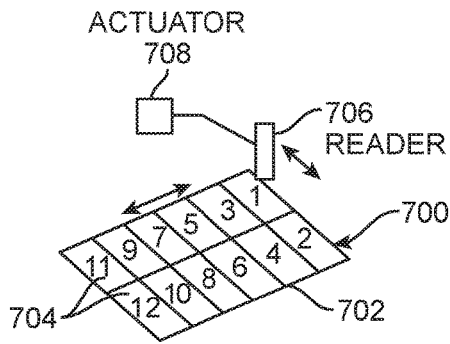

FIG. 7A

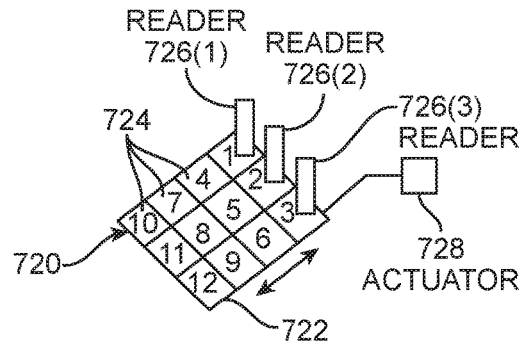

FIG. 7B

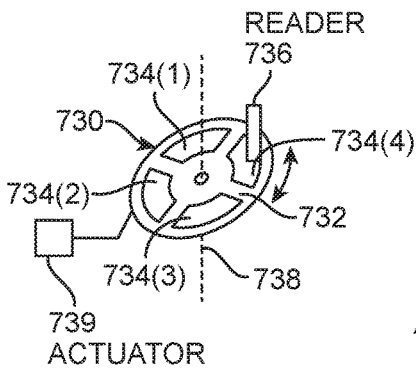

FIG. 7C

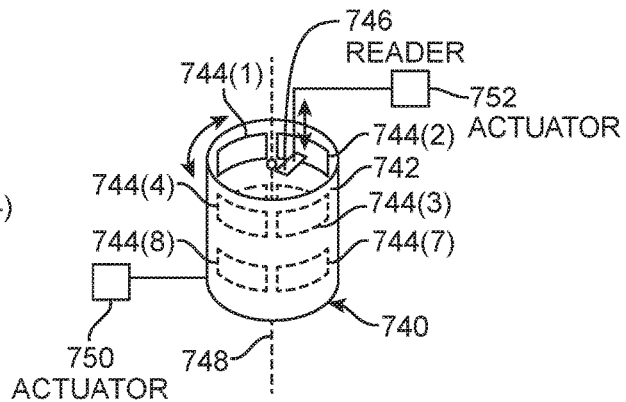

FIG. 7D

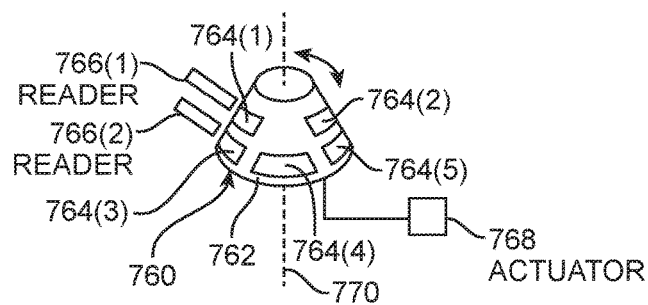

FIG. 7E

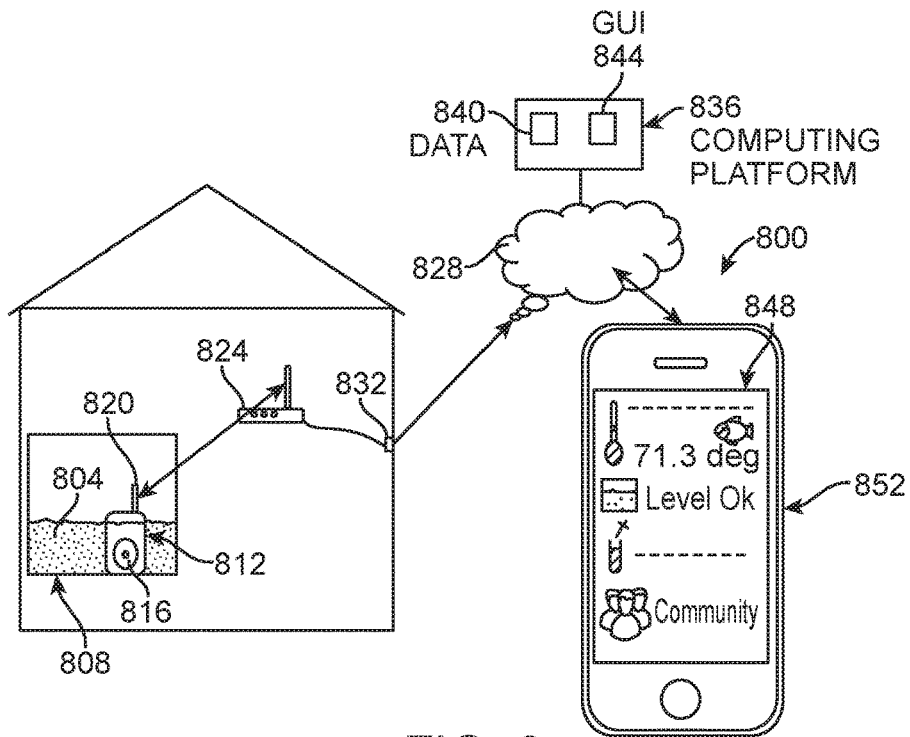

FIG. 8

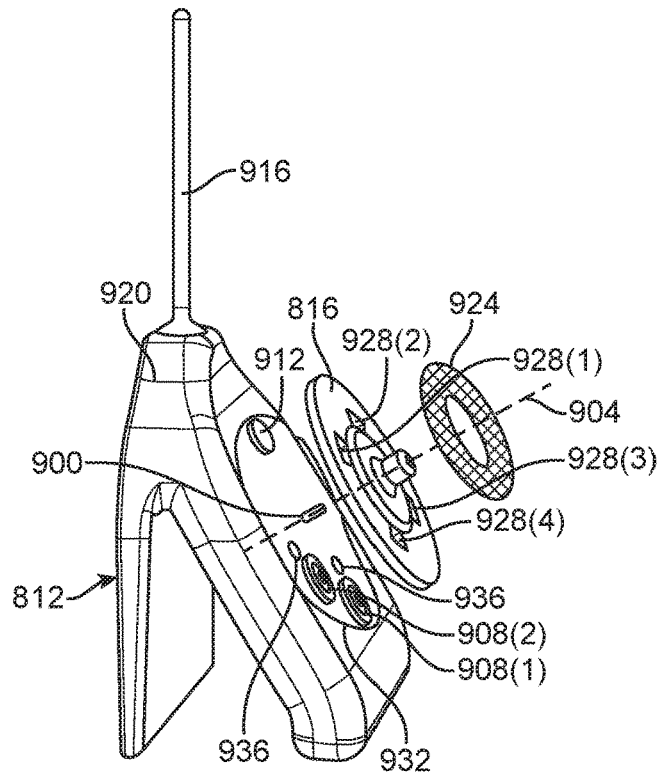

FIG. 9

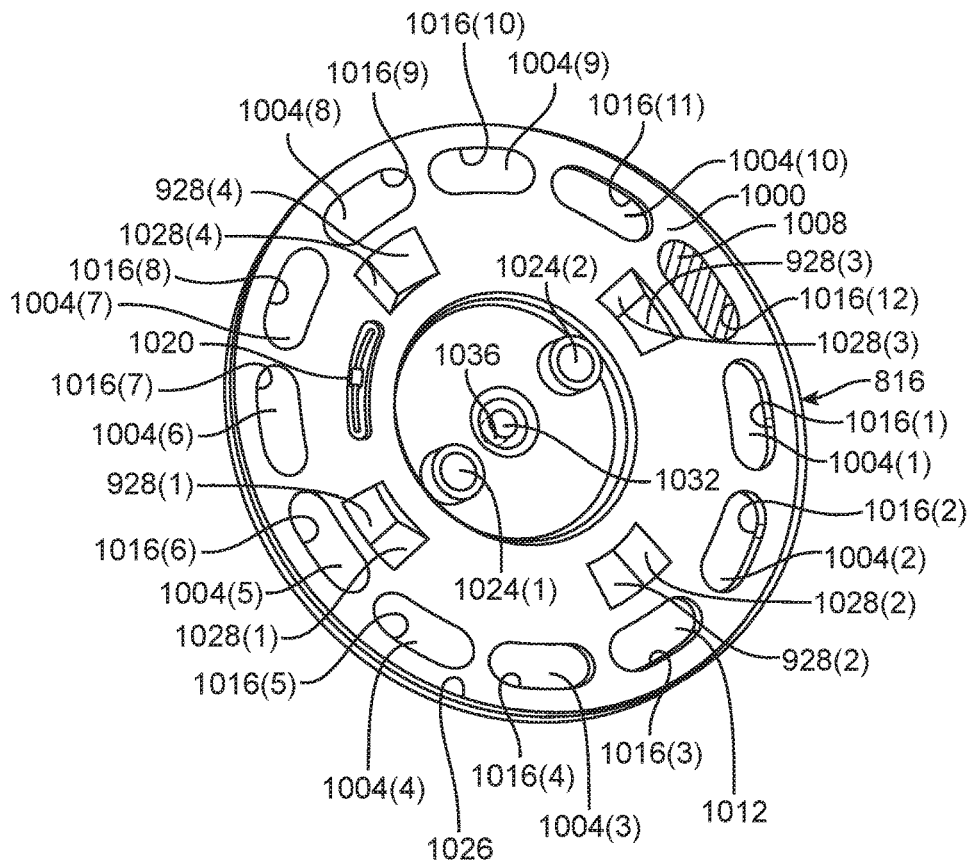

FIG. 10

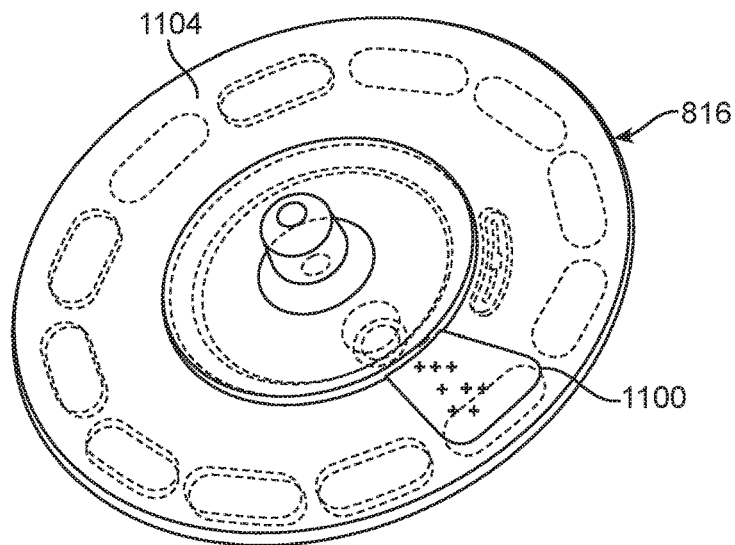

FIG. 11

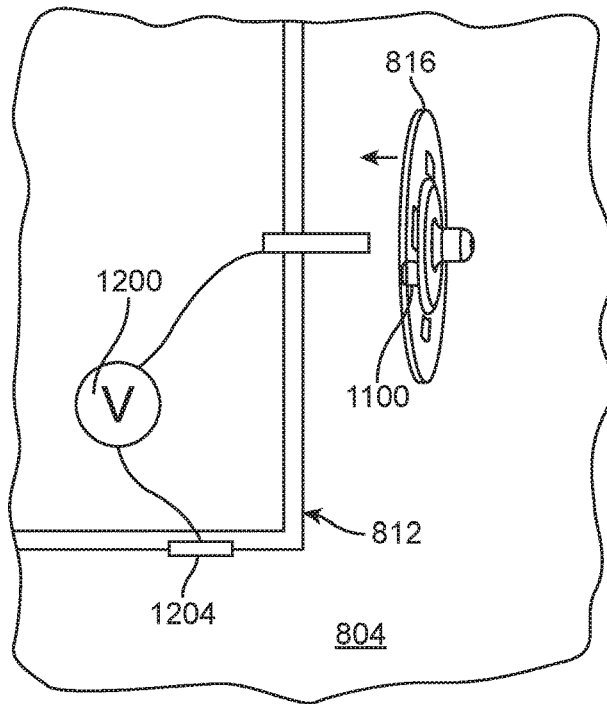

FIG. 12

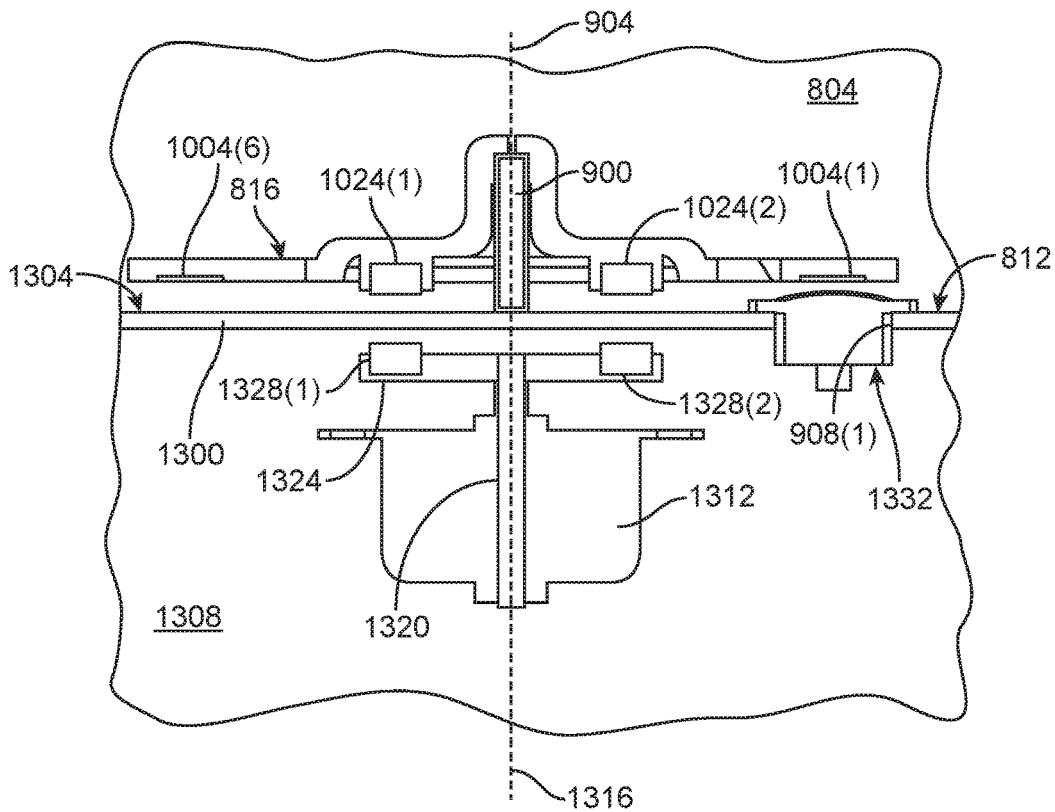

FIG. 13

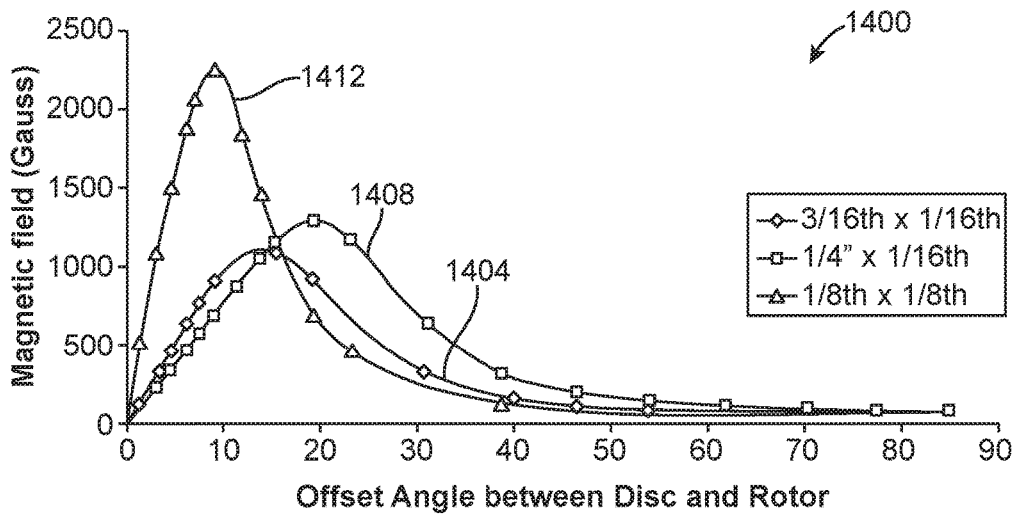

FIG. 14

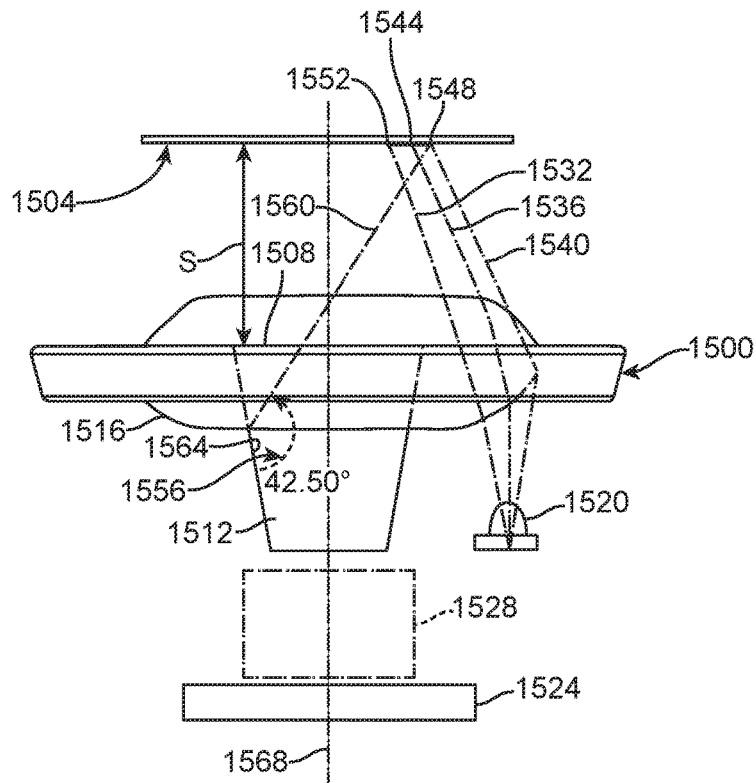

FIG. 15

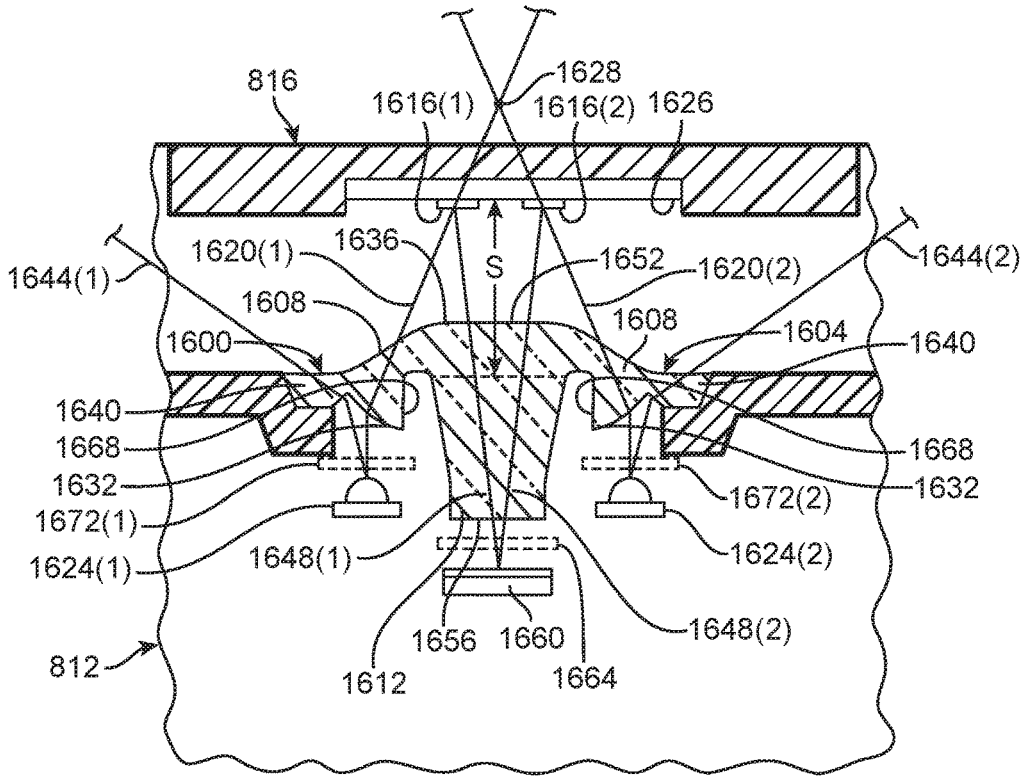

FIG. 16

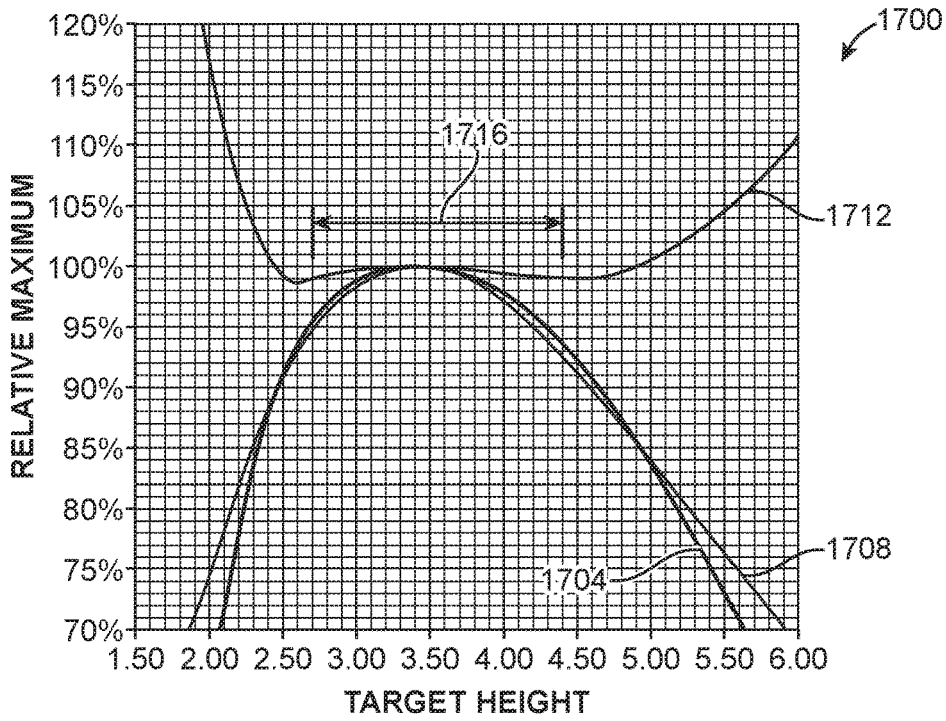

FIG. 17

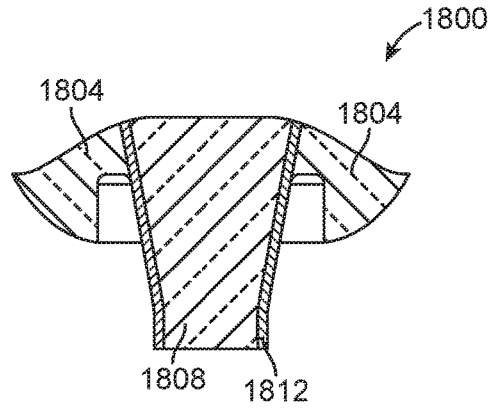

FIG. 18

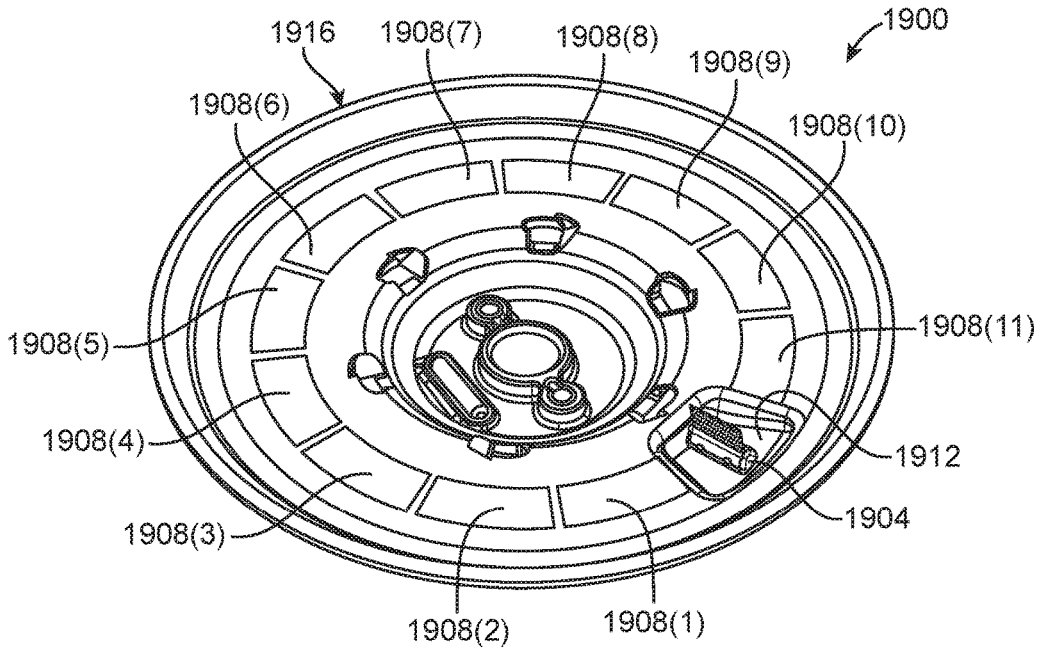

FIG. 19

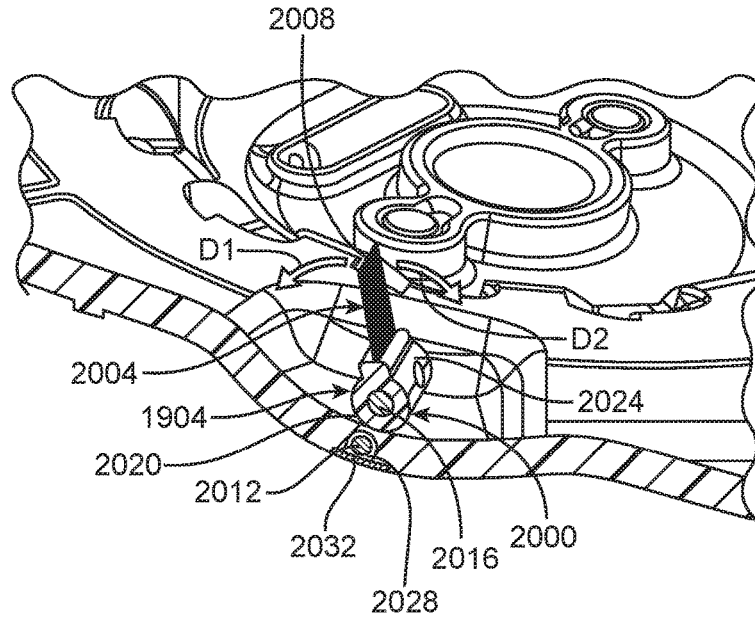

FIG. 20

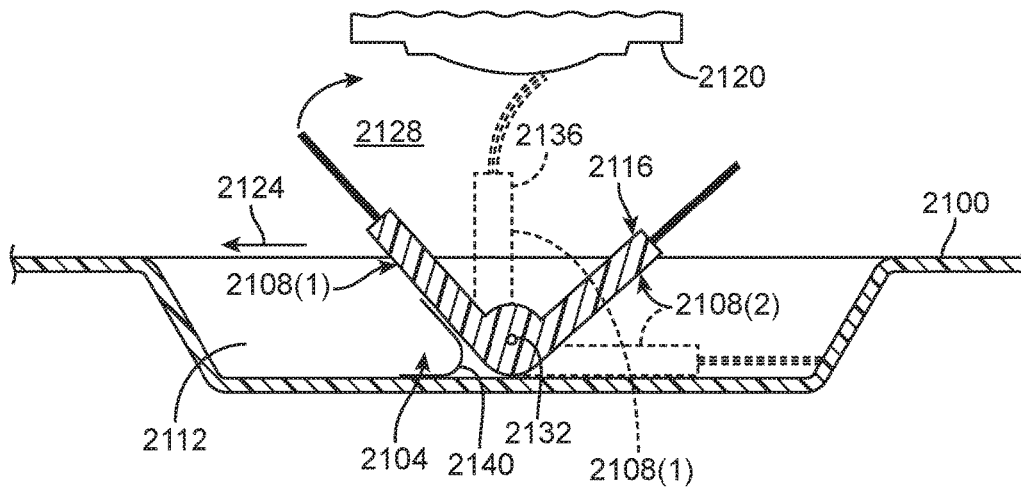

FIG. 21

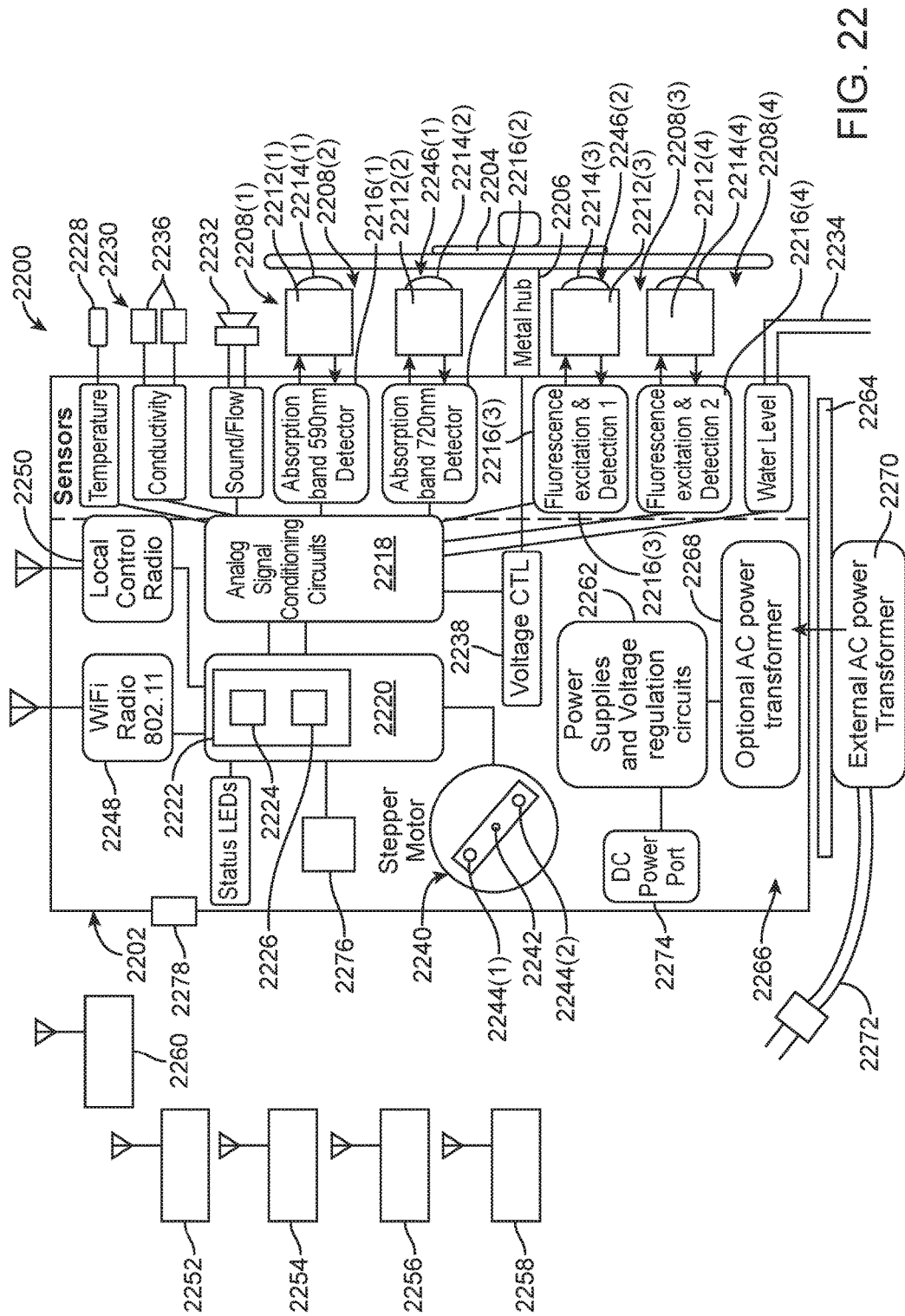

FIG. 22

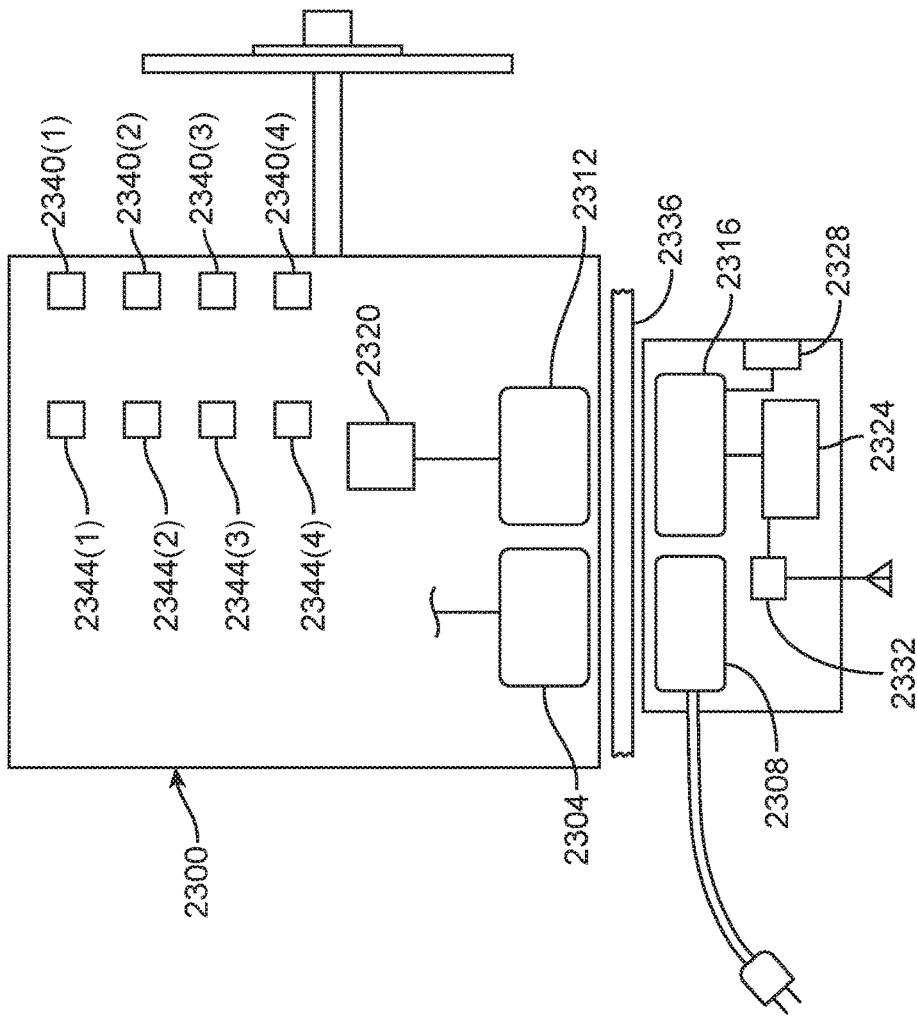

FIG. 23

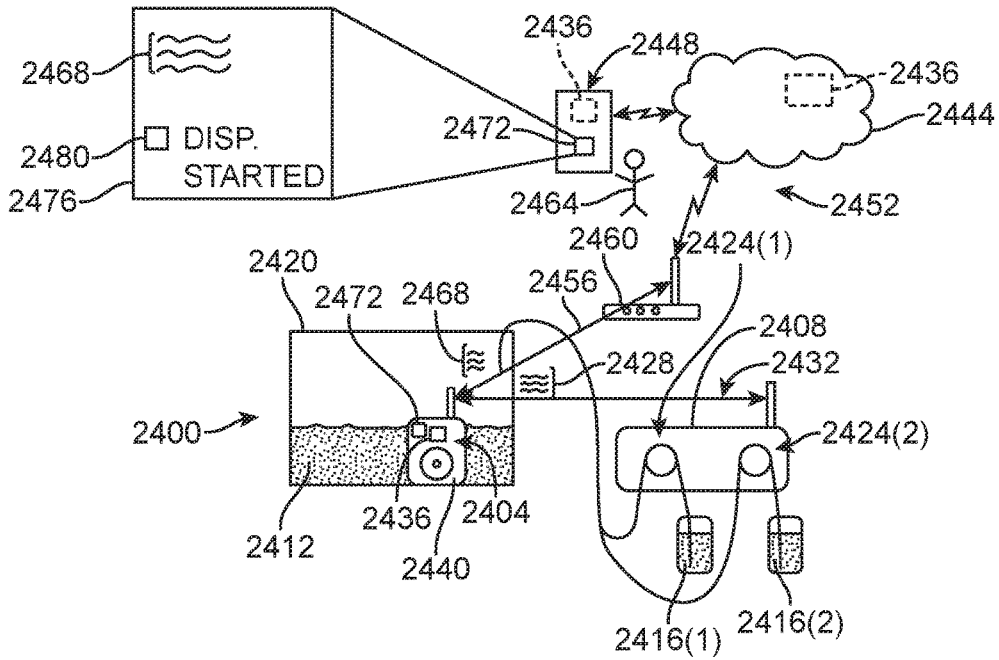

FIG. 24

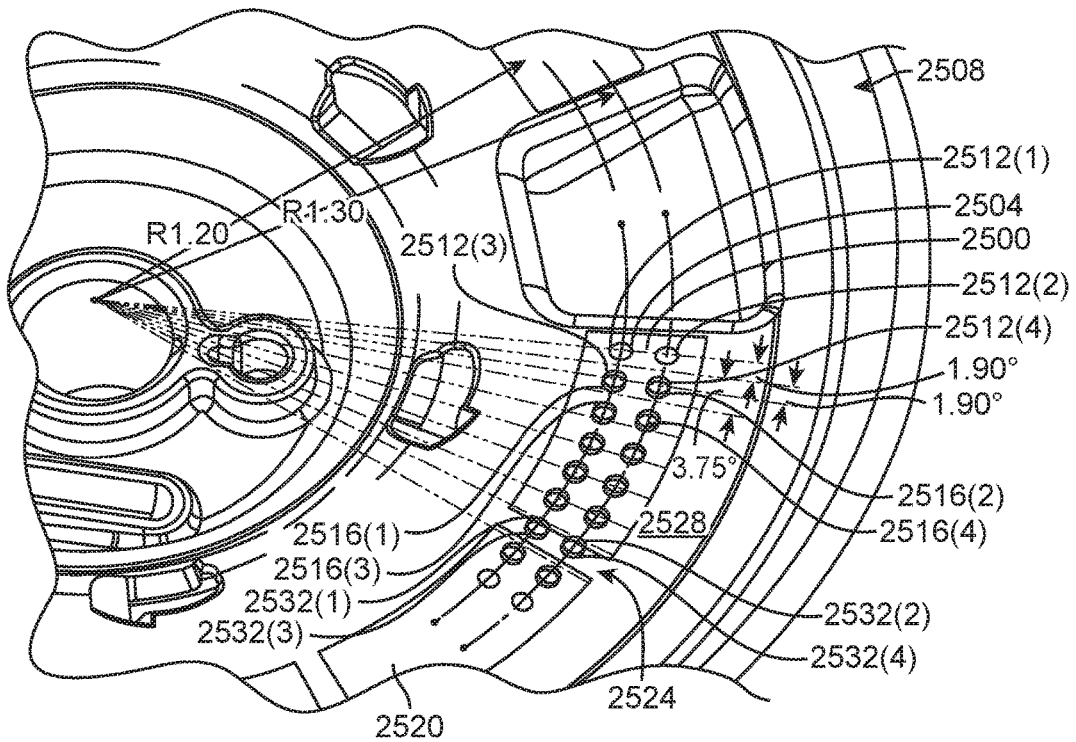

FIG. 25

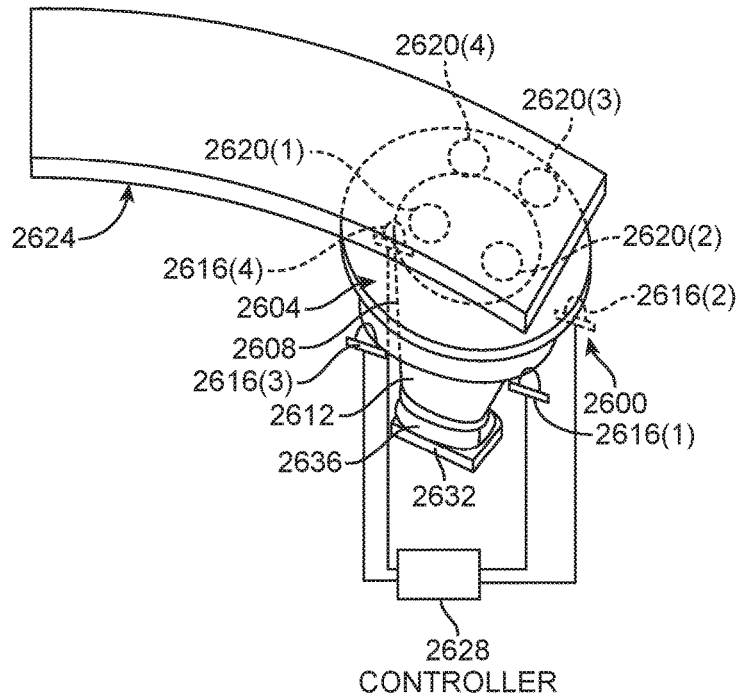

FIG. 26

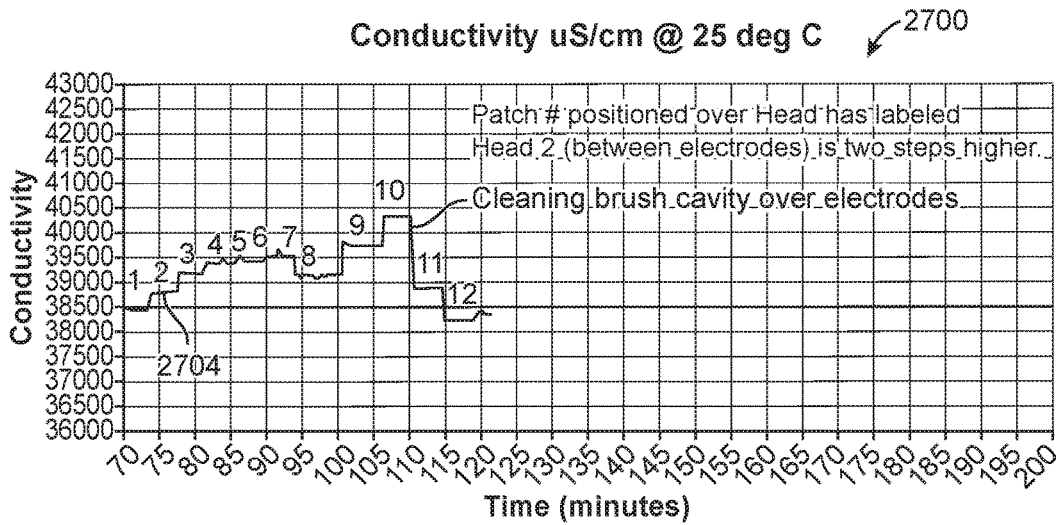
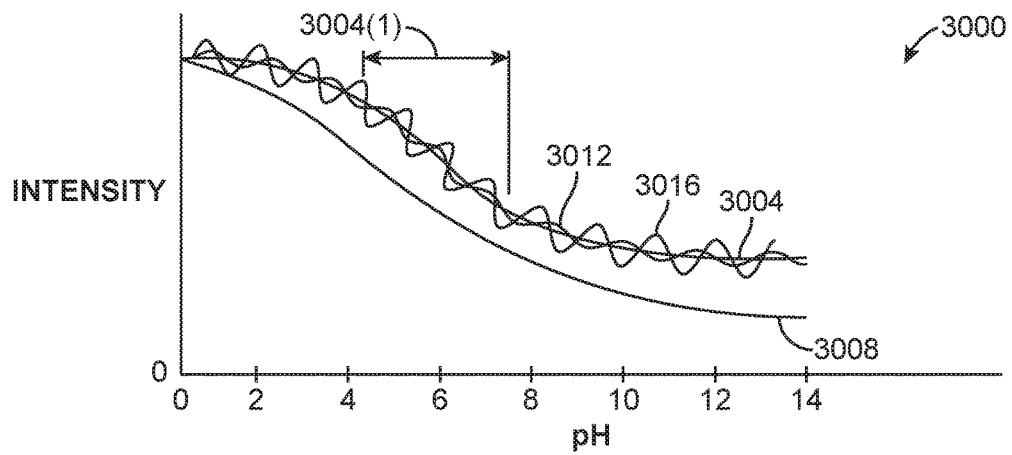
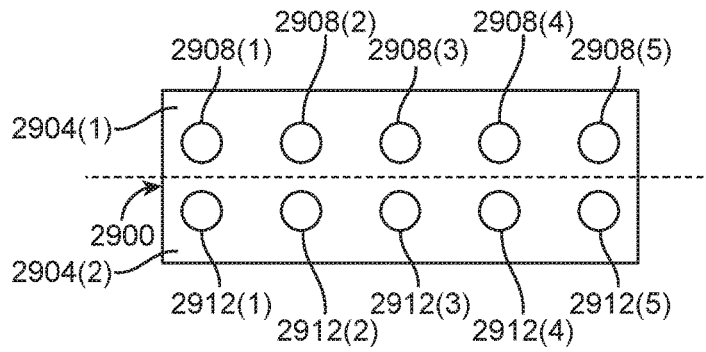
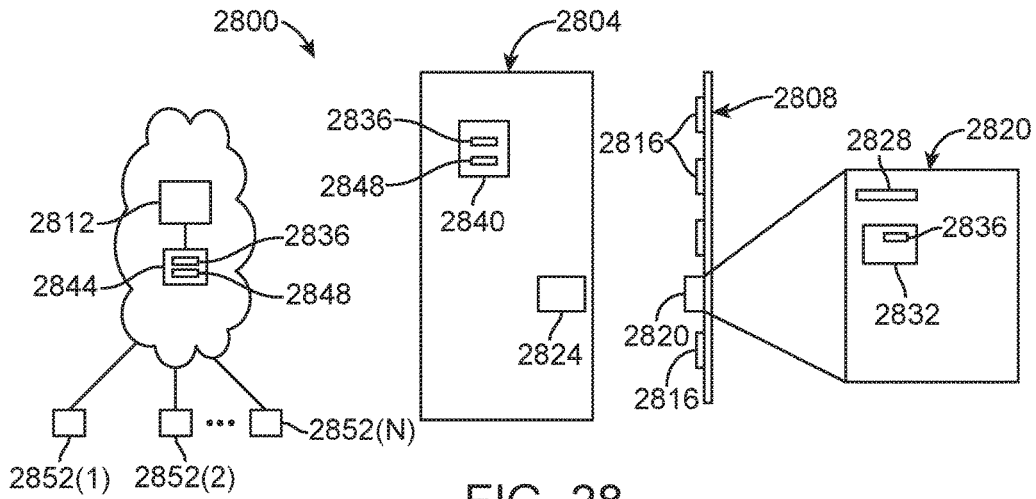

FIG. 27



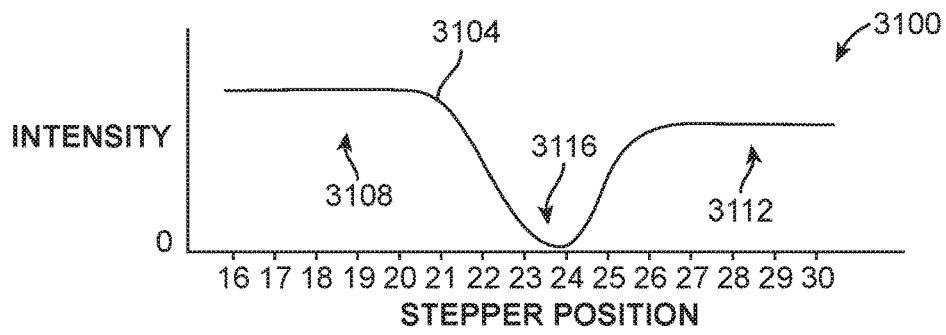

FIG. 31

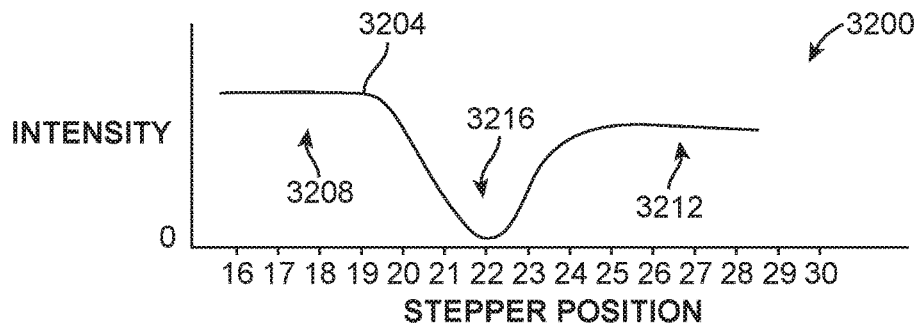

FIG. 32

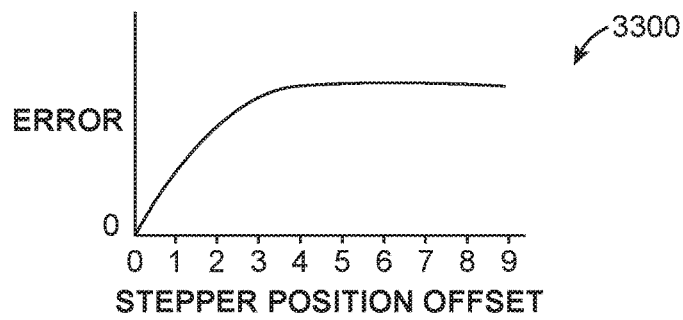

FIG. 33

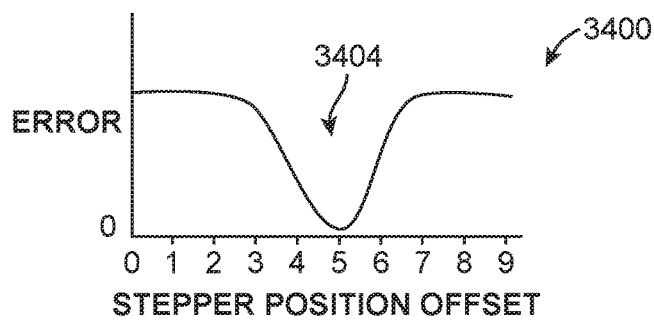

FIG. 34

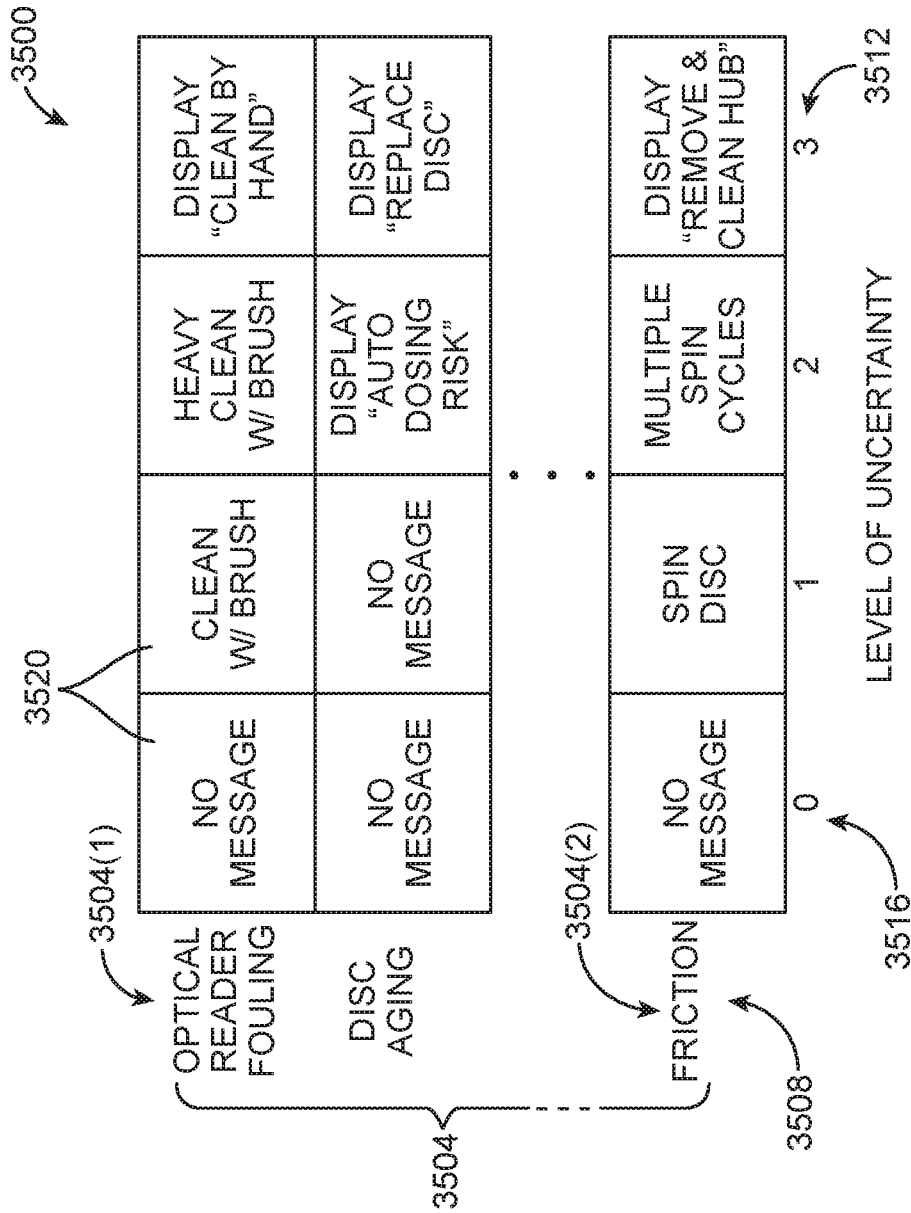

FIG. 35

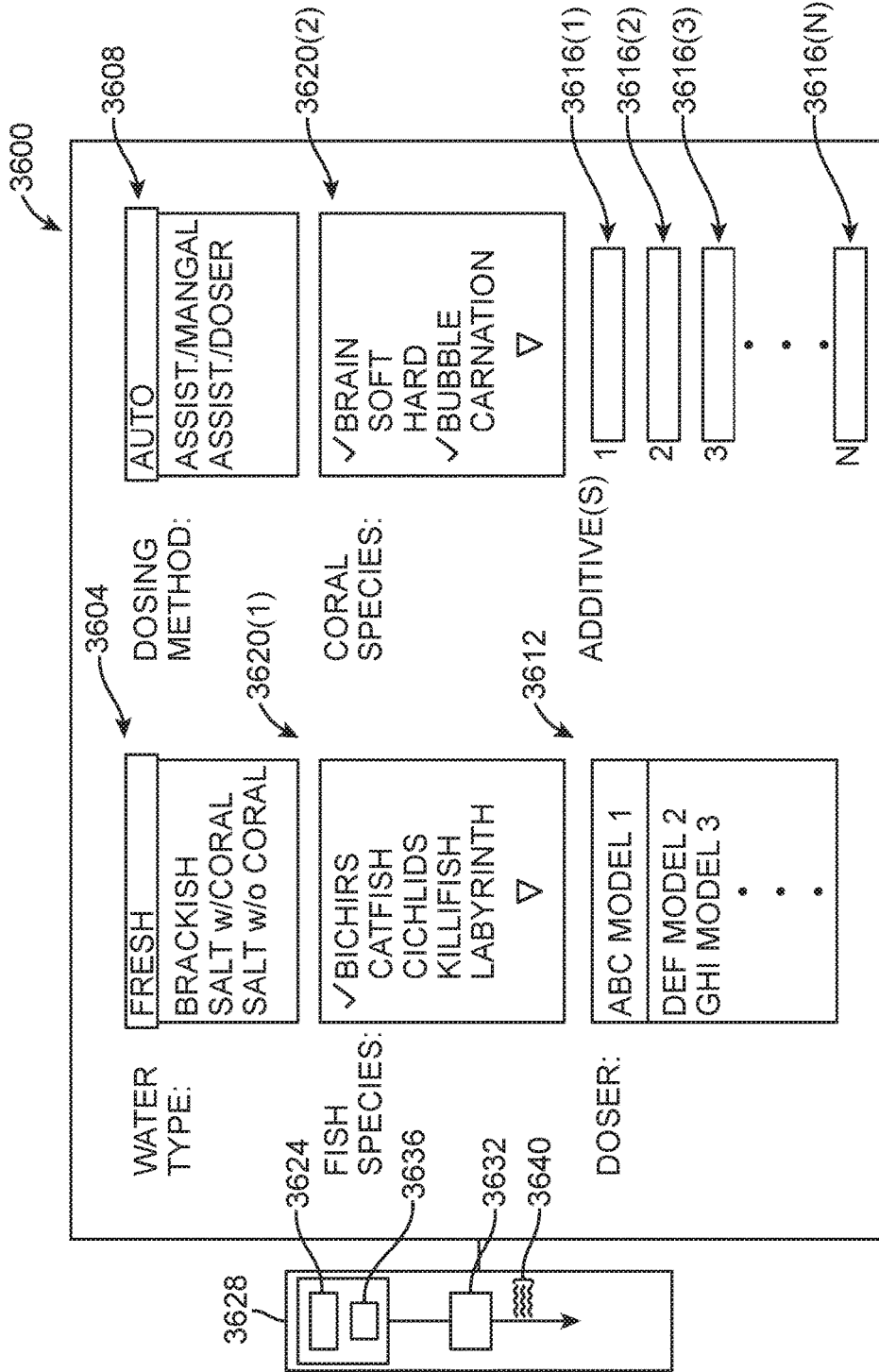

FIG. 36

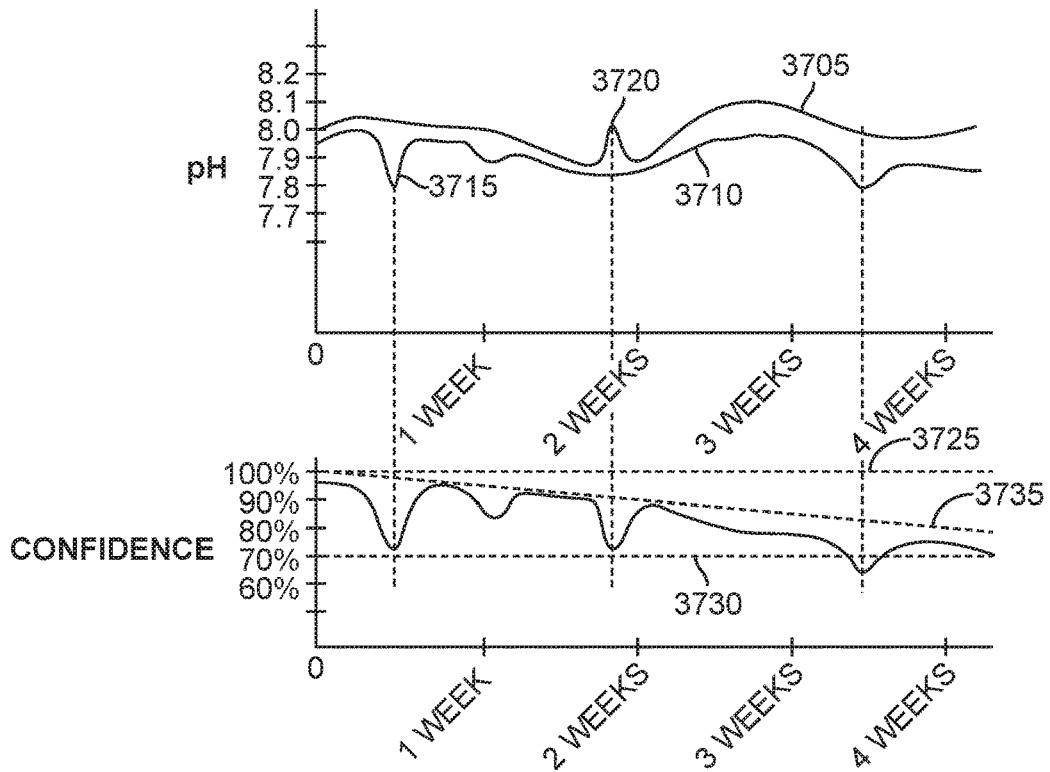

FIG. 37A

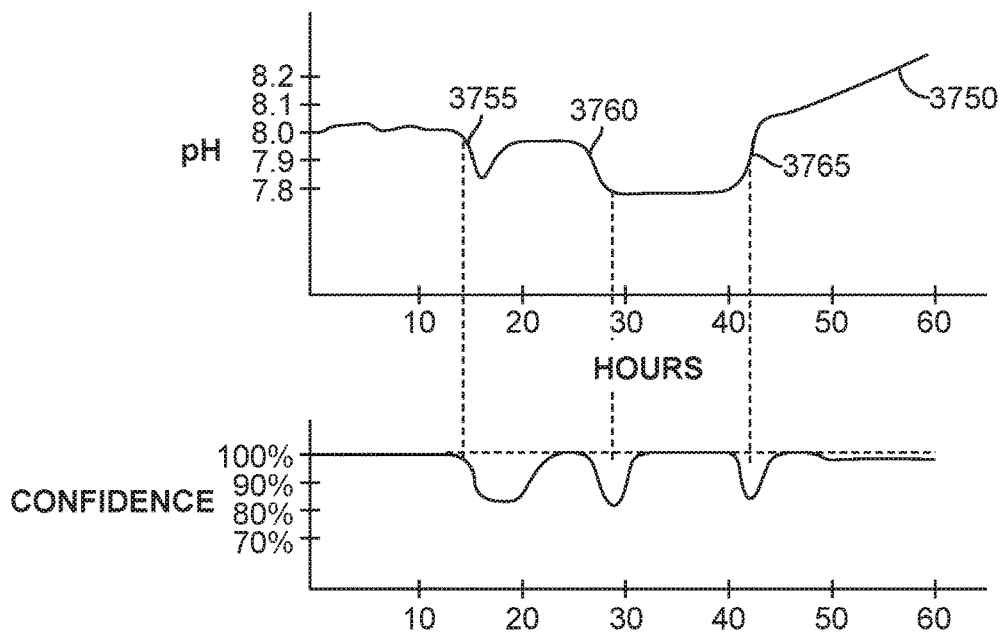

FIG. 37B

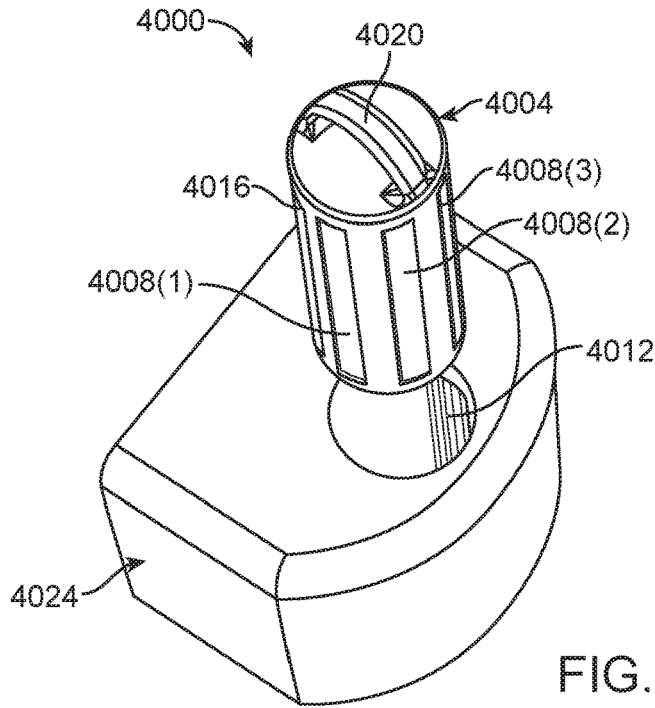

FIG. 40

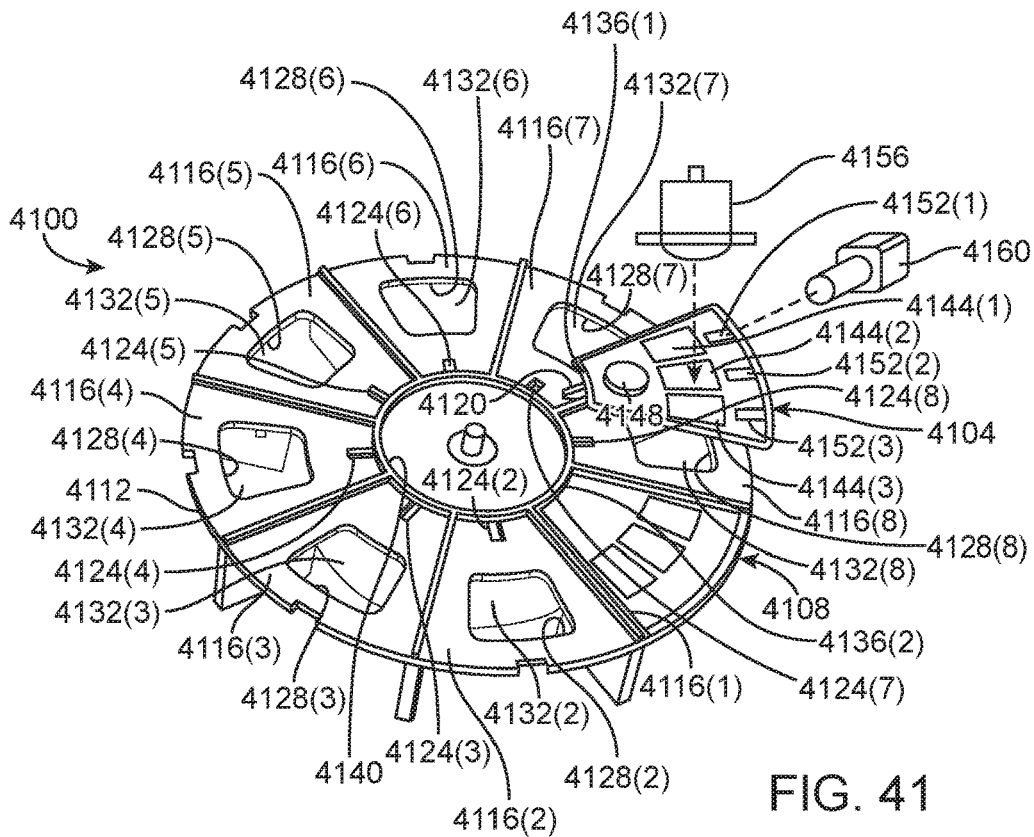

FIG. 41

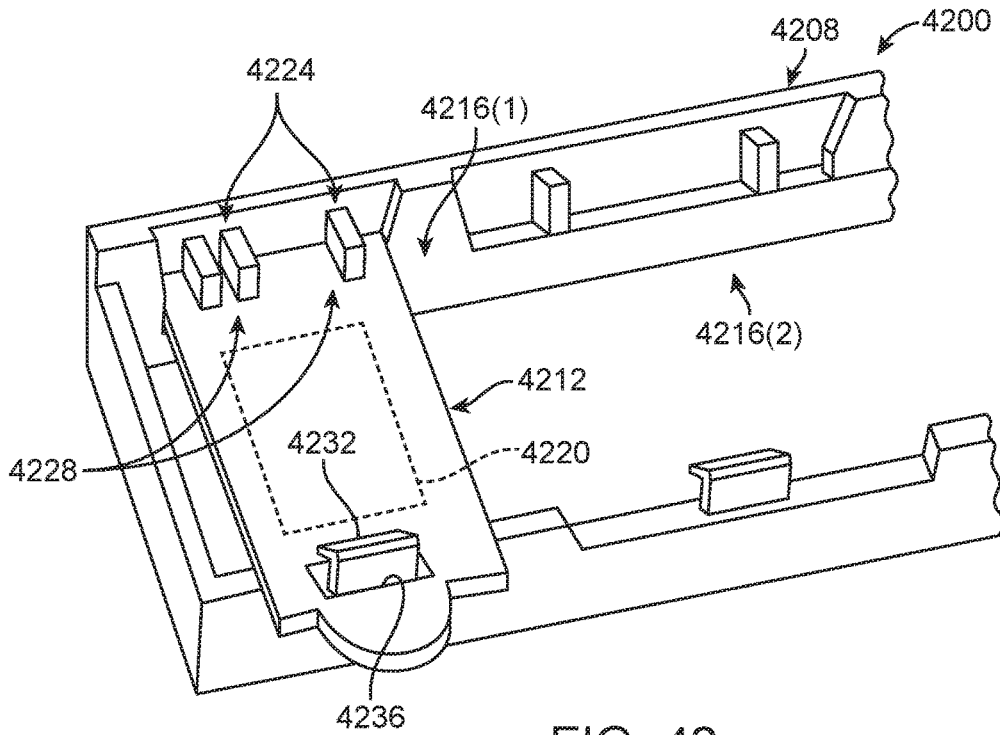

FIG. 42

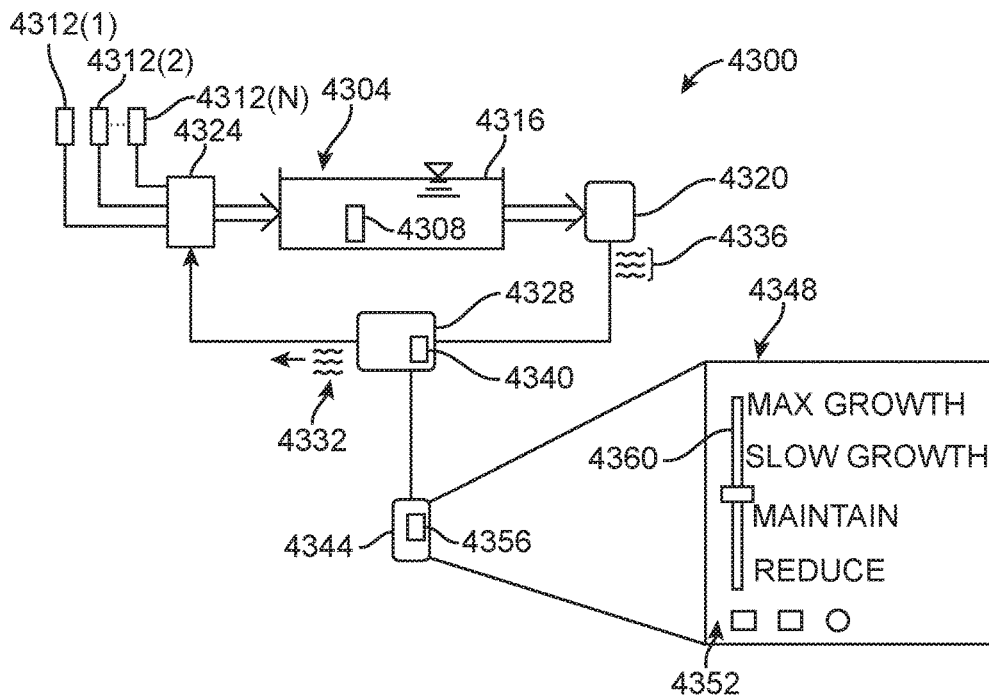

FIG. 43

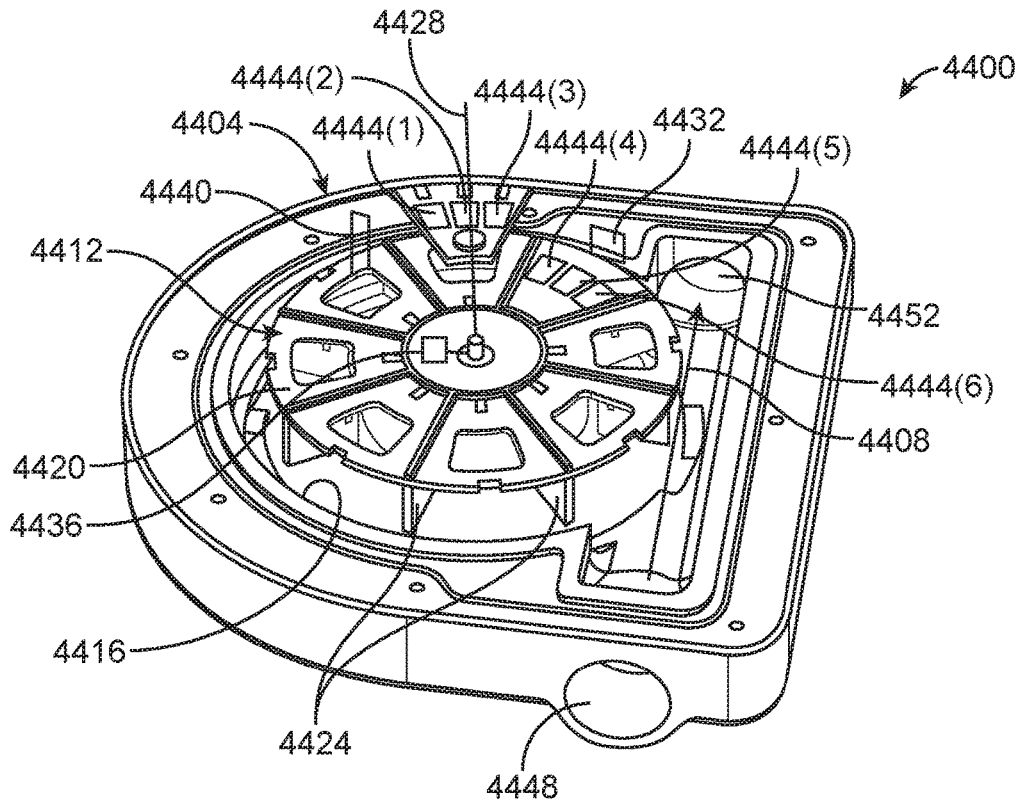

FIG. 44

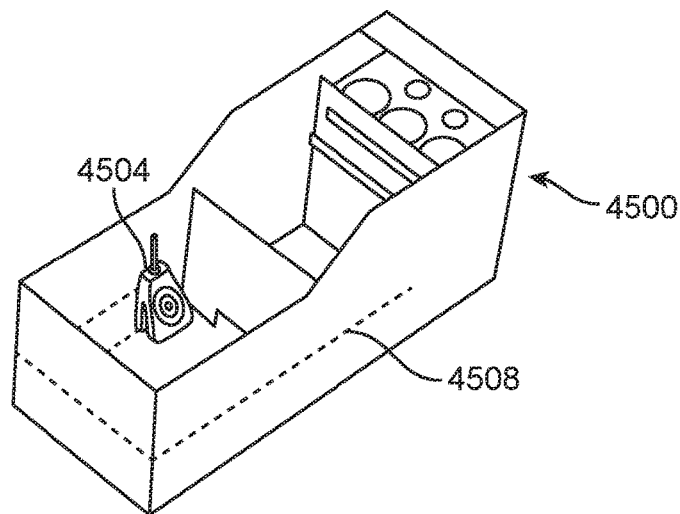

FIG. 45

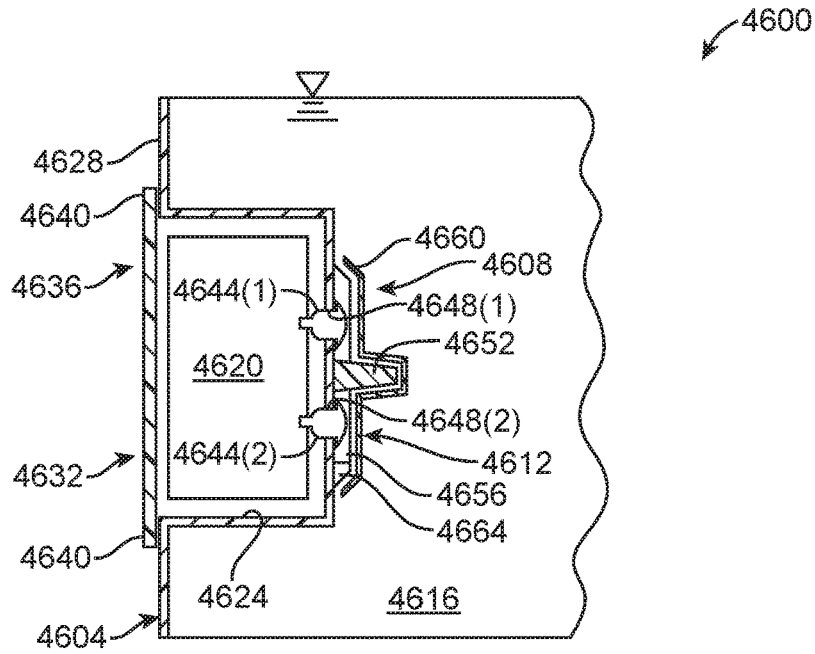

FIG. 46

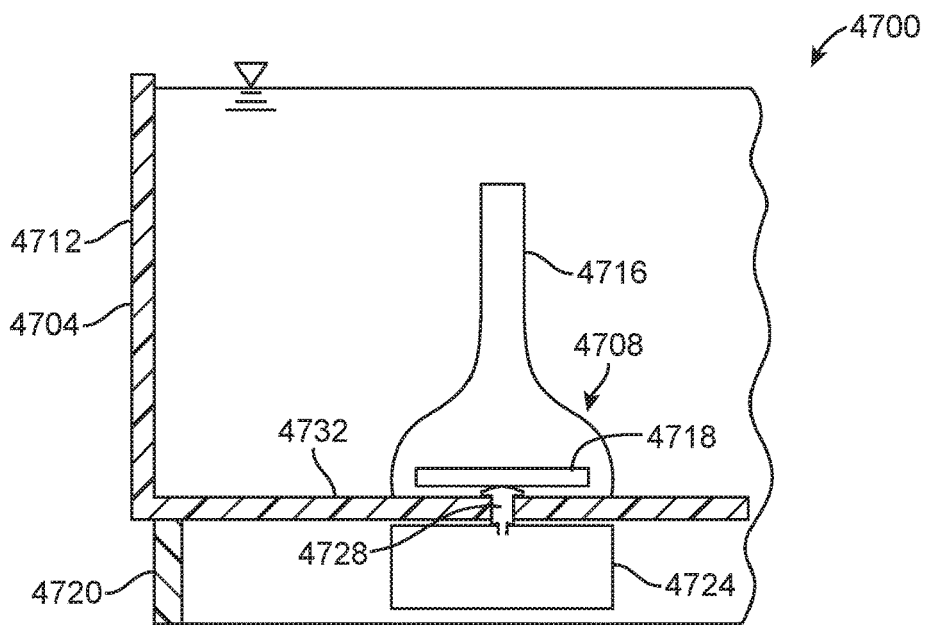

FIG. 47

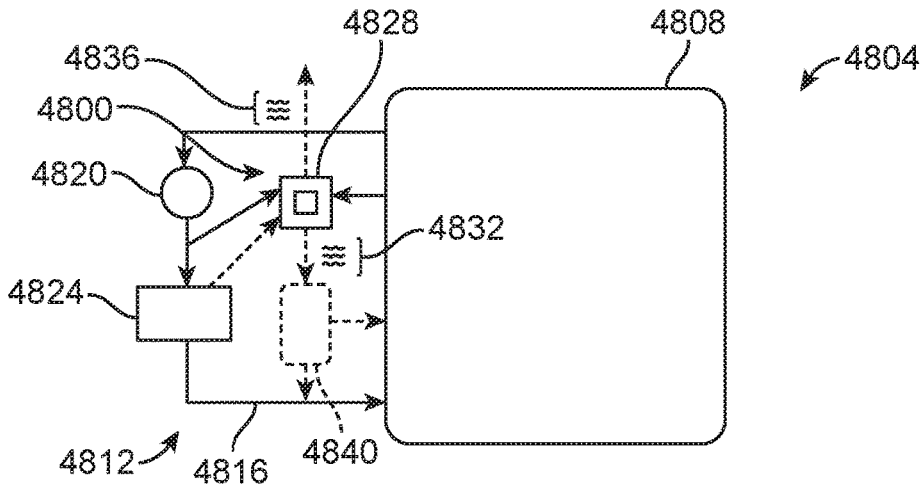

FIG. 48

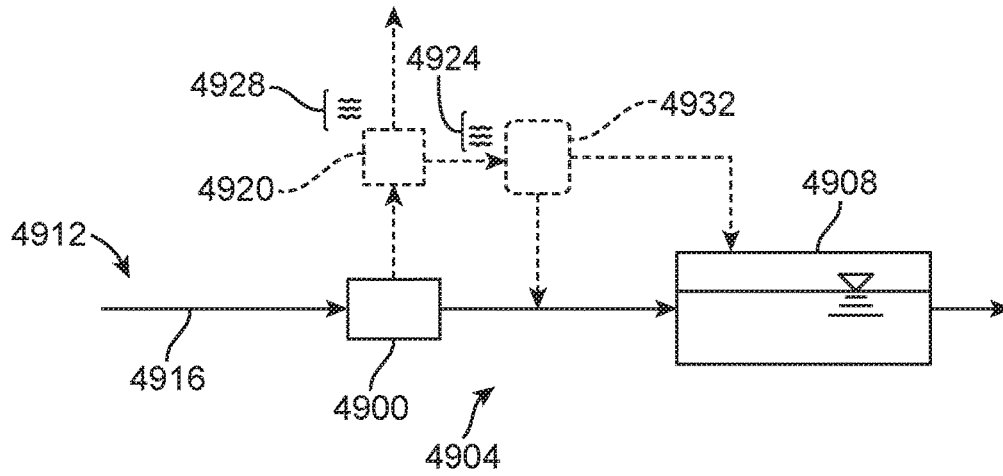

FIG. 49

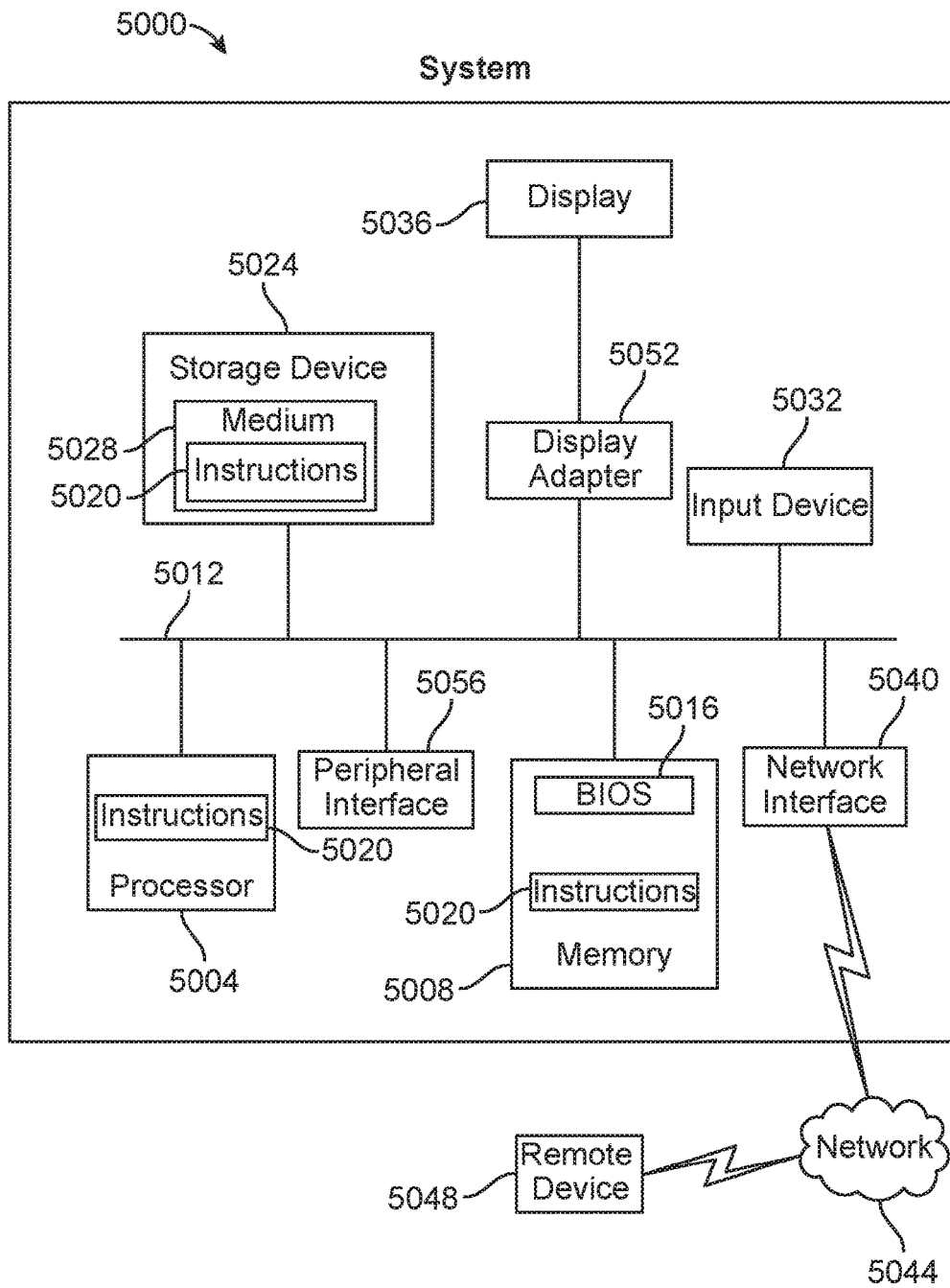

FIG. 50

**ERROR MONITORING AND CORRECTION
SYSTEMS AND METHODS IN AQUATIC
ENVIRONMENT MONITORING**

RELATED APPLICATION DATA

This application is a continuation application of U.S. patent application Ser. No. 13/713,568, filed on Dec. 13, 2012, entitled “Embedded Indicator Dye Monitoring System and Method for An Aquatic Environment,” which application is a continuation application of International Application No. PCT/US12/69209, filed Dec. 12, 2012, entitled “Aquatic Environment Monitoring and Dosing Systems and Apparatuses, and Methods and Software Relating Thereto,” which application claims the benefit of priority of U.S. Provisional Patent Application Ser. No. 61/630,450, filed Dec. 12, 2011, entitled “Aquarium Monitor,” each of which are incorporated by reference herein in their entirety.

This application is related to commonly-owned U.S. patent application Ser. No. 13/713,495, entitled “Submersible Chemical Indicator Apparatuses For Use In Aquatic-Environment Monitoring/Measuring System,” now U.S. Pat. No. 9,023,281, issued on May 5, 2015; and U.S. patent application Ser. No. 13/713,537, entitled “Aquatic Environment Water-Quality Monitor Having a Submersible Chemical Indicator Wheel,” now U.S. Pat. No. 8,883,079, issued on Nov. 11, 2014; and U.S. patent application Ser. No. 13/713,595, entitled “Combined Illuminator/Light Collectors For Optical Readers,” now U.S. Pat. No. 9,494,526, issued on Nov. 15, 2016; and U.S. patent application Ser. No. 13/713,629, entitled “Dosage Protection System and Method For An Aquatic Environment,” now U.S. Pat. No. 8,828,728, issued on Sep. 9, 2014; and U.S. patent application Ser. No. 13/713,668, entitled “Chemical Indicator Obstruction Detection System and Method For An Aquatic Environment,” now U.S. Pat. No. 8,797,523, issued on Aug. 5, 2014; and U.S. patent application Ser. No. 13/713,714, entitled “Rate of Change Protection System and Method for an Aquatic Environment,” now abandoned; and U.S. patent application Ser. No. 13/713,737, entitled “Monitoring of Photo-Aging of Light-Based Chemical Indicators Using Cumulative Exposure Tracking, and Systems, Methods, Apparatuses, and Software Relating Thereto,” now abandoned; and U.S. patent application Ser. No. 13/713,773, entitled “Monitoring of Photo-Aging of Light-Based Chemical Indicators Using Illumination-Brightness Differential Scheme, and Systems, Methods, Apparatuses, and Software Relating Thereto,” now U.S. Pat. No. 9,261,462, issued on Feb. 16, 2016; and U.S. patent application Ser. No. 13/713,818, entitled “Assisted Dosing of Aquatic Environments For Maintaining Water Quality Therein, and Systems, Methods, Apparatuses, and Software Relating Thereto,” now abandoned; and U.S. patent application Ser. No. 13/713,864, entitled “Optical Reader Optic Cleaning Systems Having Motion Deployed Cleaning Elements, and Methods of Cleaning An Optical Reader Optic,” now U.S. Pat. No. 9,494,527, issued on Nov. 15, 2016, each of which was filed on Dec. 13, 2012, each of which is incorporated by reference herein in its entirety.

FIELD OF THE INVENTION

The present invention generally relates to the field of water quality management, such as for fish and coral aquariums, swimming pools, and hot tubs, among other aquatic environments. In particular, the present invention is directed

to aquatic environment monitoring and dosing systems and apparatuses, and methods and software relating thereto.

BACKGROUND

Measuring and maintaining the quality of water is important in a wide variety of circumstances. For example, for keeping fish and/or other aquatic life, the quality of the water must be kept within certain tolerances to keep the aquatic life healthy. As another example, the water in swimming and diving pools, hot tubs, and other sports, recreational, and therapeutic bodies of water need to be kept at certain levels of quality not only to maintain that water’s clarity, but also to keep the users of these bodies of water safe from waterborne illnesses. As yet another example, the quality of potable water needs to be maintained within a range of tolerances as to a variety of chemical constituents for any one or more of a number of reasons, such as to make the water safe for ingesting, less harmful to distribution systems, and to promote healthfulness of the drinkers (e.g., in the case of adding fluorine and/or other nutrients). Those skilled in the art will readily appreciate that these are but a few examples of settings in which it is important to monitor and/or control the quality of water.

SUMMARY OF THE DISCLOSURE

In one implementation, a method of monitoring errors in an aquatic environment monitoring system is provided. The method includes measuring a plurality of error values in the environment monitoring system using the environment monitoring system, each of the plurality of error values being an error value related to a condition selected from the group consisting of a degradation in a chemical indicator due to photo-aging, a degradation in a chemical indicator due to water-aging, a physical contamination of a chemical indicator, an illumination imbalance related to an optical reader, a degradation of a light source of an optical reader, a physical contamination in water between an optical reader and a chemical indicator, a displacement due to friction between a chemical indicator apparatus and a monitoring unit, an error intrinsic in a chemical indicator, an error in distance between a chemical indicator apparatus and an optical reader, and any combinations thereof; determining a confidence level based on the plurality of error values; comparing the confidence level to a threshold value associated with the aquatic environment monitoring system; and generating a correction instruction based on said comparing using a dosing calculator associated with the aquatic environment monitoring system, the correction instruction for correcting a condition associated with the plurality of error values.

In another implementation, an aquatic environment monitoring system is provided. The system includes an optical reader; one or more chemical indicators; a processing element; and a memory element having stored instructions executable by the processing element for: measuring a plurality of error values in the environment monitoring system using the environment monitoring system, each of the plurality of error values being an error value related to a condition selected from the group consisting of a degradation in a chemical indicator due to photo-aging, a degradation in a chemical indicator due to water-aging, a physical contamination of a chemical indicator, an illumination imbalance related to an optical reader, a degradation of a light source of an optical reader, a physical contamination in water between an optical reader and a chemical indicator, a

displacement due to friction between a chemical indicator apparatus and a monitoring unit, an error intrinsic in a chemical indicator, an error in distance between a chemical indicator apparatus and an optical reader, and any combinations thereof; determining a confidence level based on the plurality of error values; comparing the confidence level to a threshold value associated with the aquatic environment monitoring system; and generating a correction instruction based on said comparing using a dosing calculator associated with the aquatic environment monitoring system, the correction instruction for correcting a condition associated with the plurality of error values.

In still another implementation, a machine-readable hardware storage medium including machine-executable instructions for performing a method of monitoring errors in an aquatic environment monitoring system is provided. The instructions include a set of instructions for measuring a plurality of error values in the environment monitoring system using the environment monitoring system, each of the plurality of error values being an error value related to a condition selected from the group consisting of a degradation in a chemical indicator due to photo-aging, a degradation in a chemical indicator due to water-aging, a physical contamination of a chemical indicator, an illumination imbalance related to an optical reader, a degradation of a light source of an optical reader, a physical contamination in water between an optical reader and a chemical indicator, a displacement due to friction between a chemical indicator apparatus and a monitoring unit, an error intrinsic in a chemical indicator, an error in distance between a chemical indicator apparatus and an optical reader, and any combinations thereof; a set of instructions for determining a confidence level based on the plurality of error values; a set of instructions for comparing the confidence level to a threshold value associated with the aquatic environment monitoring system; and a set of instructions for generating a correction instruction based on said comparing using a dosing calculator associated with the aquatic environment monitoring system, the correction instruction for correcting a condition associated with the plurality of error values.

BRIEF DESCRIPTION OF THE DRAWINGS

For the purpose of illustrating the invention, the drawings show aspects of one or more embodiments of the invention. However, it should be understood that the present invention is not limited to the precise arrangements and instrumentalities shown in the drawings, wherein:

FIG. 1 is high-level block/schematic diagram illustrating an aquatic environment setup that includes a water quality monitoring and dosing system;

FIG. 2 is a high-level block/schematic diagram illustrating an exemplary implementation of a water quality monitoring and dosing system that utilizes a communications network for implementing various functionalities of and/or relating to the system;

FIG. 3 is a high-level block/schematic diagram illustrating an exemplary implementation of a standalone water quality monitoring and dosing system;

FIG. 4 is a high-level block/schematic diagram illustrating a chemical indicator reading system;

FIG. 5 is a cross-sectional view illustrating an exemplary arrangement for a chemical indicator on a chemical indicator apparatus;

FIG. 6 is a cross-sectional view illustrating an alternative exemplary arrangement for a chemical indicator on a chemical indicator apparatus;

FIG. 7A is high-level schematic diagram illustrating a first exemplary chemical indicator apparatus/reader arrangement;

FIG. 7B is high-level schematic diagram illustrating a second exemplary chemical indicator apparatus/reader arrangement;

FIG. 7C is high-level schematic diagram illustrating a third exemplary chemical indicator apparatus/reader arrangement;

FIG. 7D is high-level schematic diagram illustrating a fourth exemplary chemical indicator apparatus/reader arrangement;

FIG. 7E is high-level schematic diagram illustrating a fifth exemplary chemical indicator apparatus/reader arrangement;

FIG. 8 is a schematic diagram illustrating an exemplary aquarium monitoring system that includes a discoidal chemical monitoring apparatus;

FIG. 9 is a partially exploded perspective view of the water quality monitoring system of FIG. 8;

FIG. 10 is an isometric view of a chemical indicator disc that can be used, for example, with the monitoring system of FIG. 9;

FIG. 11 is an isometric view of another chemical indicator disc that can be used, for example, with the monitoring system of FIG. 9, wherein the disc includes a reading-range-enhancing electrode for enhancing the reading range of a chemical indicator onboard the disc;

FIG. 12 is a schematic diagram illustrating how the reading range of a chemical indicator can be enhanced using electrical charge;

FIG. 13 is a cross-sectional view illustrating several components of the monitoring system of FIG. 8;

FIG. 14 is a graph of x-axis magnetic field strength versus offset angle for several exemplary magnet sizes in a magnetic drive coupling that can be used in a monitoring/measuring system of the present disclosure;

FIG. 15 is a diagram illustrating design considerations that can be used to design a combined I/LC of the present disclosure;

FIG. 16 is an enlarged view of an optical reader that includes a unitary monolithic combined illuminator/light collector (I/LC) that can be used in a water quality monitoring system;

FIG. 17 is an exemplary graph of relative maximum reading intensity versus target height for the combined I/LC of FIG. 16;

FIG. 18 is an alternative combined I/LC that is an assembly of separately manufactured parts;

FIG. 19 is an isometric view of a chemical indicator disc having a cleaning element for cleaning one or more components of a water quality monitoring unit;

FIG. 20 is an enlarged partial cross-sectional view of the cleaning element of FIG. 19;

FIG. 21 is a partial cross-sectional view of another cleaning element that can be used with a chemical indicator apparatus for cleaning one or more components of a water quality monitoring/measuring unit;

FIG. 22 is a schematic/block diagram illustrating various components of the monitoring system of FIG. 8;

FIG. 23 is a schematic/block diagram illustrating a monitoring system having non-wired communication of power and data;

FIG. 24 is a schematic diagram of an aquarium setup having automated dosing functionality;

FIG. 25 is a partial perspective view of a chemical indicator disc, illustrating chemical indicators aboard the disc being read in a multi-reading mode;

FIG. 26 is an isometric view of an optical reader system that illuminates a target with multiple spots of illumination;

FIG. 27 is an exemplary graph of conductivity versus time illustrating the use of water-conductivity electrodes being used to determine the distance of a chemical indicator apparatus from the electrodes;

FIG. 28 is a schematic/block diagram of a system that enables storage of data on a chemical indicator apparatus;

FIG. 29 is a plan view of a chemical indicator and ten measurement illumination spots, five being of one brightness and five being of a second brightness, for illustrating a method of compensating for photo-aging of the chemical indicator;

FIG. 30 is an exemplary plot of reading intensity versus expose time for a particular chemical indicator illustrating a method of compensating for photo-aging of the chemical indicator;

FIG. 31 is a graph of reading intensity versus stepper position for readings of two chemical indicators when moving a chemical indicator disc in a clockwise direction;

FIG. 32 is a graph of reading intensity versus stepper position for readings of two chemical indicators when moving the chemical indicator disc in a counterclockwise direction;

FIG. 33 is a graph of combined error between clockwise and counterclockwise chemical indicator readings versus stepper offset wherein no friction is present between the chemical indicator disc and its mount(s);

FIG. 34 is a graph of combined error between clockwise and counterclockwise chemical indicator readings versus stepper offset wherein friction is present between the chemical indicator disc and its mount(s);

FIG. 35 illustrates a confidence matrix for a water quality monitoring system for use in determining actions as a function of uncertainty of reading accuracy based on various error inducers;

FIG. 36 illustrates a screenshot of a graphical user interface that allows a user to input information for implementing a water-quality monitoring and dosing system in an aquarium setup;

FIG. 37A illustrates one example of a confidence level plot for exemplary measured pH values;

FIG. 37B illustrates another example of a confidence level plot for exemplary measured pH values;

FIG. 38 is an isometric view of an exemplary linear combined I/LC that can be used in an optical reader;

FIG. 39 is an elevational view of a water quality monitor having a stationary magnetic drive for driving a chemical indicator disc;

FIG. 40 is a partially exploded view of a water quality monitoring system having a cylindrical chemical indicator apparatus;

FIG. 41 is a partial schematic/partial isometric view diagram illustrating a rotary chemical indicator apparatus having replaceable chemical indicator elements;

FIG. 42 is a partial isometric view of a linear chemical indicator apparatus having replaceable keyed chemical indicator elements;

FIG. 43 is a schematic/block diagram of a coral aquarium setup having an automated dosing system that can control the growth rate of coral;

FIG. 44 is an isometric view of part of a water quality monitoring system designed and configured to be installed in plumbing;

FIG. 45 is an isometric view of an aquarium sump containing a water quality monitoring system;

FIG. 46 is a partial cross-sectional view of a water quality monitoring system in which electrical components are located outside of the water being monitored;

FIG. 47 is a partial cross-sectional view/partial block diagram of a water quality monitoring system concealed in an aesthetic feature inside an aquarium;

FIG. 48 is a high-level schematic diagram of a closed-loop setup having a water circulation system containing a water quality monitoring system and optional dosing system;

FIG. 49 is a high-level schematic diagram of an open-loop setup having a feed-water system containing a water quality measuring system and optional dosing system; and

FIG. 50 is a high-level diagram of a computing system that can be used to contain and execute software instructions for implementing one or more of the functionalities described herein.

DETAILED DESCRIPTION

Some aspects of the present invention are directed to systems for measuring and/or monitoring the quality of water in various aquatic environments and for dosing, when the monitoring determines that the water quality is outside one or more predetermined tolerances, the water with one or more additives in corresponding respective amounts that bring the water quality into the predetermined tolerance(s). As those skilled in the art will readily understand from reading this entire disclosure, despite the fact that this introductory section addresses systems for monitoring and/or dosing, other aspects of the present invention lie within individual components, apparatuses, methods, and software of such a system, as well as within methods, apparatuses, systems, and software not directly involved in monitoring and/or dosing but related thereto, such as systems, methods, and software for social networking based on water quality monitoring and methods, systems and apparatuses that are especially adapted to be used with various monitoring and dosing systems and apparatuses disclosed herein.

Before describing several exemplary water quality monitoring and dosing systems, the term “aquatic environment” is defined, for example, to give the reader a sense of the wide applicability of the systems, apparatuses, methods, and software disclosed herein. As used herein and in the appended claims, “aquatic environment” shall mean any environment wherein water is present and for which it is desired to measure at least one parameter indicative of a quality of the water. In turn, “quality” is measured by the presence, absence, and/or amount of one or more chemicals, including minerals, in the water, and/or the presence, absence, and/or amount of one or more other materials, such as organic matter, inorganic particles, bacteria, etc., in the water, and any combination thereof. Examples of aquatic environments include, but are not limited to: aquariums, including aquarium sumps and aquarium plumbing; swimming/diving/wave pools, including swimming/diving/wave pool plumbing; hot tubs, including hot tub plumbing; fish ponds, including fish pond plumbing; potable water supplies, including plumbing therefor; sewage treatment infrastructure; water fountains; water displays; lakes and lagoons, and control structures and plumbing therefor (such as at amusement parks and other facilities having highly controlled environments); and food processing facilities that use water, for example, to wash food items, cook food items, transport food items, to name just a few. Those skilled in the

art will certainly be able to think of other examples of aquatic environments for which teachings of the present disclosure will be pertinent. In this connection, while many of the examples herein are directed to aquarium set ups for keeping fish, coral, and/or other aquatic life, skilled artisans will readily be able to adapt the fundamental teachings herein to virtually any other aquatic environment wherein water quality measurement and/or monitoring and dosing is desired.

Referring now to the drawings, FIG. 1 illustrates a water quality monitoring and dosing system 100 being used to monitor one or more parameters of water 104 in an aquatic environment 108 and to provide proper dosing of one or more additives 112 to the water so that the quality of the water is maintained within its desired tolerance(s), depending on the number and type of parameters measured. It is noted that aquatic environment 108 can be any aquatic environment, such as one of the aquatic environments noted above, wherein water quality monitoring and dosing is desired. It is also noted that examples of measurable parameters are described below in detail. That said, those skilled in the art of water quality measuring will readily understand which one or more water parameters need to be measured for a given aquatic environment.

System 100 includes a monitoring system 116, a dosing calculator 120, and a dosing system 124. Before describing each of these parts of system 100, it is noted that the diagram in FIG. 1 does not necessarily represent distinct components of the system, rather, this diagram is intended to convey functionality of the system over physical form of the system. Thus, while system 100 can be composed of components that correspond in a one-to-one manner to the functionality blocks of FIG. 1, this need not be so. For example, dosing calculator 120 need not be a standalone device; it can be in any suitable form, such as a set of software instructions executed onboard a component of monitoring system 116, onboard a component of dosing system 124, or onboard another component or device, such as a computing device (not shown) (e.g., webserver, smartphone, home computer, laptop computer, tablet computer, desktop computer, etc.) located remotely from aquatic environment 108. Because those skilled in the art will be able to conjure a variety of ways of discretizing and componentizing the functionality blocks representing monitoring system 116, dosing calculator 120, and dosing system 124, it is not necessary to describe all combinations and permutations herein for those skilled artisans to appreciate the myriad ways that system 100 of FIG. 1 can be implemented across components local to aquatic environment 108 and/or across components located remotely relative to the aquatic environment.

Monitoring system 116 is designed and configured to monitor (i.e., measure repeatedly) at least one parameter indicative of the quality of water 104 in aquatic environment 108. Though the number of measured parameters can be as few as one, in many applications, such as aquarium monitoring applications, the number of measured parameters will typically be four or more, as will be seen below in the context of specific examples. Monitoring system 116 can monitor each of the parameters using one or more suitable technology(ies), such as one or more chemical indicators that each undergo a physical change that can be sensed (read), one or more electrodes, one or more chemical probes, among others, and any combination thereof. Monitoring system 116 generates one or more outputs 128 indicative of the measurement(s) taken by the monitoring system and outputs the resulting signal(s) to dosing calculator 120. In one example, monitoring system 116 takes the measure-

ment(s) and outputs the corresponding output(s) 128 multiple times (e.g., periodically or at differing intervals) over a given time period in a manner that attempts to ensure that none of the measured parameters goes out of range or goes out of range long enough to risk damage to aquatic environment 108, its contents, and/or its users. Each output 128 can be in any suitable form, such as a raw analog signal, a raw digital signal, or a digitally converted value, among others. The type of output used in a particular implementation may depend, for example, on whether dosing calculator 120 is implemented within monitoring system 116 where raw signals can be readily utilized or outside of the monitoring system, such as in dosing system 124 or on a remote device, such as a computing device (not shown) (e.g., laptop computer, tablet computer, webserver, smartphone, desktop computer etc.), where it is easier to convey converted values via a suitable communications protocol, such as transmission control protocol/Internet protocol (TCP/IP), among others. Other examples of computing devices that can be used are disclosed below in connection with FIG. 50.

Dosing calculator 120 is designed and configured to determine whether or not any one or more of the measured parameters are out of acceptable range and, if so, how much of one or more additives 112 that dosing system 124 should add to water 104 with the goal of restoring the one or more out-of-range parameters to the corresponding respective acceptable ranges. Depending on the type of a particular additive 112, the dosing may be made all at once or it may be made over a period of time. For example, some additives cannot be added too quickly without detrimental effects, and so need to be dosed at a rate that avoids the detrimental effects. In order for dosing calculator 120 to make its out-of-range and dosing determinations, it must know certain information about aquatic environment 108 and/or water 104, such as the volume of the water, the nature of environment (e.g., it contains certain fauna and/or flora), and the acceptable range(s) of the measured parameter(s), among others. Dosing calculator 120 may communicate dosing instructions 132 to dosing system 124 in any manner suited to the implementation. For example, if dosing calculator 120 is located so that it must use a data communications protocol, such as TCP/IP, the dosing instructions may include the additive type(s) and an amount of each additive 112 that dosing system 124 should dispense. In another data communications protocol example, the dosing instructions can include instructions that tell dosing system 124 which additive(s) to dispense and how long to dispense each additive needed. This latter example requires that dosing calculator 120 knows how much additive is dispensed per unit of time. In other implementations in which dosing calculator 120 communicates directly with dosing system 124, the instructions can be in another form, such as a voltage signal or a digital signal. As will become apparent from reading this entire disclosure, monitoring system 116 can comprise or consist of any of the monitoring systems, or part(s) thereof, described herein or any other suitable monitoring system. Likewise, dosing calculator 120 can be implemented in any suitable manner, such as any one of the manners described in this disclosure. Similarly, dosing system 124 can comprise any of the dosing systems, or part(s) thereof, described herein or any other suitable dosing system. It is noted that although FIG. 1 has been described above as including monitoring system 116, dosing calculator 120, and dosing system 124, an aquatic environment setup of the present disclosure can include any one or combination of those components or other similar components, several examples of which are described in this disclosure. In

addition, it is noted that while monitoring system **116**, dosing calculator **120**, and dosing system **124** are described above without much detail on specific features, it is noted that any one of these components can be provided with any one or more of the applicable features described herein relative to specific examples.

FIG. 2 illustrates an exemplary embodiment of a water quality monitoring and dosing system **200** implemented over a communications network **204**, which comprises wired communications links, wireless communications links, or both. Examples of a communications network include, but are not limited to, a local area network, a wide area network, a cellular telecommunications network, and a global network (e.g., the Internet), other network type, and any combination thereof. System **200** includes an aquatic environment **208** containing water **212** that is monitored by a monitoring system **216** for one or more parameters relating to its quality and is dosed, as necessary, with one or more additives by a dosing system **220** in a manner that maintains the quality of the water within one or more tolerance bands. As with system **100** of FIG. 1 above, monitoring system **216** and dosing system **220** of FIG. 2 can be, for example, any of the monitoring systems and dosing systems, respectively, described herein or any other suitable monitoring or dosing system. Also as with system **100** of FIG. 1, the one or more parameters can be any parameter(s) relevant to the nature of the water quality at issue.

Monitoring system **216** includes a monitor **224** that monitors one or more of the parameters, for example, by reading one or more indicator devices (not shown), such as one or more chemical indicators, one or more electrodes, one or more probes, etc. In the exemplary system **200** of FIG. 2, monitoring system **216** generates monitor data **228** containing information regarding readings of the one or more parameters and sends the monitor data to a data processor **232** via communications network **204**. Data processor **232**, which can reside on one or more computing systems **236**, for example, on one or more web servers, one or more client devices (e.g., tablets computers, laptop computers, smartphones, etc.) or other computing system in data communication with communications network **204**, processes monitor data **228** as needed to allow the monitor data to be displayed to a user and/or to control dosing system **220**. In this connection, data processor **232** can include a dosing calculator **240**. Alternatively, dosing calculator **240** can be located elsewhere, such as within dosing system **220**. In addition, if dosing calculator **240** is not part of data processor **232**, monitor data **228** can be processed by data processor **232** prior to being sent to dosing calculator **240** or, alternatively, the monitor data can be sent directly to the dosing calculator.

Each computing system **236** may also include a user interface **244** that allows a user to access monitoring data **228** either in its unprocessed format or in a processed format, or both. As an example of unprocessed format, researchers, professional aquarists, enthusiasts, troubleshooters, etc., may find it desirable to have all of the “raw” data provided by monitor **224**. On the other hand, consumers, casual users, hobbyists, etc., may only desire a version of monitor data **228** that has been processed, such as to present the data to the user in a simplified form, such as graphically, binary (e.g., in tolerance/out of tolerance), etc. Those skilled in the art will readily be able to understand the benefits and formats of processed and unprocessed formats of monitor data **228**, such that further description is not necessary herein for them to appreciate the broad scope of the present invention. It is noted that the processing and

displaying of monitor data **228** and data derived therefrom through processing can be distributed over two or more computing systems **236**. For example, in a webserver/client context, the webserver may provide some initial processing of monitor data **228** while a client device, for example, via a smartphone “app” (i.e., a software application), receives the processed data from the webserver and uses that data to generate one or more suitable graphical displays on the client device representing the monitor data.

In another example, a client device may receive unprocessed monitor data **228**, in which case a software application on the client device may use the unprocessed data directly to create suitable graphical displays and/or allow a user to use the unprocessed monitor data in another way. As yet another example, a computing system **236**, such as a smartphone, laptop computer, tablet computer, desktop computer, etc., may receive monitor data **228** directly, for example, via a wired or wireless data connection, and that system may include a software application for processing monitor data **228**, or not, and use either the processed data or unprocessed data, or both, in any suitable manner, such as for producing graphical displays or transferring the data to a spreadsheet or other program for detailed analysis, among many other possibilities. In still a further example, monitor **224** itself may provide a relatively high level of data processing, such that monitor data **228** is already processed for high level use, such as graphical display by one or more computing system **236**. It is noted that if monitor **224** processes its reading data, it may contain one or more onboard displays **248**, which can be, for example, visual (e.g., visual indicator(s), electronic display(s), etc.), aural (e.g., sound generator for generating one or more sounds, spoken words, etc.), or a combination of visual and aural displays.

Dosing calculator **240** can be embodied and realized in any of a number of ways. In addition to being located at various locations within system **200** as noted above, dosing calculator **240** can be configured to provide dosing instructions for manual dosing or automated dosing, or both. Manual dosing can be performed in any one or more of a variety of ways. For example, if dosing system **220** is manually controllable, i.e., requires a human operator to control the dosing, dosing calculator **240** can be augmented with a user interface **252** that displays an indication of the amount of each additive that the user needs to cause dosing system **220** to dispense. Depending on the type of additive and any limitations of dosing rate, such indication may be accompanied by further dosing instructions advising the user of the dosing rate parameters. In this connection, depending on how they are implemented, user interface **252** and/or dosing calculator **240** may need to be aware of information regarding dosing system **220**, such as make and model, that allow the user interface and/or dosing calculator to provide instructions specific to the dosing system being used.

In another example, dosing system **220** may not be present at all, such that the dosing needs to be carried out virtually entirely by a human user **256**, using, for example, chemicals and/or other additives that are provided in bulk form in individual containers and need to be manually dispensed or taken from such containers by the human user. In this example, if each/any of the additives is available in differing forms (e.g., powder, liquid, gel, etc.) and/or in differing concentrations, etc., then user interface **252** and/or dosing calculator **240** may need to be aware of information regarding the specific additive(s) being used, such as brand and formulation, that allow the user interface and/or dosing calculator to provide instructions specific to the particular

additive(s) being used. Examples of dosing systems and additives for particular applications are described below. However, those skilled in the art will readily understand that these examples are illustrative and not limiting.

Whereas FIG. 2 illustrates a water quality monitoring and dosing system 200 that can be monitored and/or controlled from virtually any location having access to communications network 204, which in the case of the Internet, for example, can be virtually any location on earth (e.g., using a satellite link for highly remote locations) or even off of Earth, FIG. 3 illustrates a setup 300 including a monitoring system 304 and a dosing system 308 that are in very close proximity to one another. Indeed, in some instantiations, they are combined into an integral unit with one another, and in some cases, into an integral unit with a component 312 of an aquatic environment 316, such as an aquarium, a sump, plumbing, a filter, a heater, an overflow, a skimmer, etc., and any suitable combination thereof. In other embodiments, wherein monitoring system 304 and dosing system 308 are not integrated into a common unit, they can nevertheless be located close together, such as in differing parts of aquatic environment 316 or differing parts of a component 312. Depending on the spacing of monitoring system 304 and dosing system 308 from one another, they can be in data communication via any suitable means, such as wired communication or wireless communication. Examples of suitable wireless communication includes short-range radio communication and infrared communication, among others.

In some instantiations, setup 300 can be self-contained, i.e., not require communication of monitor data to any devices outside of monitoring system 304, and dosing system 308 or communication of control data, for example, data needed to set operating parameters of the system, from any device outside of the monitoring and dosing systems. However, it is noted that system 300 can be outfitted with such external communications capability if so desired. In such cases, outside communications capability can be provided via any suitable wired or wireless technology available. In either case, monitoring system 304 and/or dosing system 308 can be provided with any suitable user interface(s), such as interfaces 320 and 324, that allow(s) a user to control operating parameters of system 300.

FIG. 4 illustrates a water parameter reading system 400 that can, for example, be adapted for use in any one of water quality monitoring and dosing systems 100, 200, and 300 of FIGS. 1, 2, and 3, respectively, or other water quality monitoring and dosing system, and/or that can be adapted for use as a water quality monitoring system and/or as a water testing system, among other things. For example, water parameter reading system 400 can be integrated into monitoring system 116 of FIG. 1 or any other monitoring system disclosed herein. In the example of FIG. 4, water parameter reading system 400 includes a chemical indicator apparatus 404 comprising a holder 408 that supports one or more chemical indicators 412(1) to 412(N) each of which is designed and configured to undergo a detectable physical change as the amount of one or more constituents/properties that make up the water (not shown) under consideration. Examples of detectable physical change include, but are not limited to, change in fluorescence, fluorescence decay (e.g., lifetime fluorescence), phase fluorescence, change in electromagnetic energy absorbance (change in reflectivity), and change in color, among others. In one embodiment, each chemical indicator 412(1) to 412(N) comprises one or more indicator dyes immobilized in a suitable medium, such as a gel, a polymer matrix (such as a cellulosic matrix), etc. In

one example, immobilization includes covalent bonding of a dye to cellulose fibers which in turn are immobilized in a medium such as a hydrogel.

In one example, when one or more of chemical indicators 412(1) to 412(N) are submersible chemical indicators, it is noted that the chemical indicators are stable in water, i.e., the active dyes remain contained in the mediums and they do not mix with, and they do not change, the water in which they are submerged. Each chemical indicator 412(1) to 412(N) is preferably reversible. Examples of constituents/properties of water, the levels of which can be detected using suitable chemical indicators, include, but are not limited to, pH, hardness, calcium, magnesium, oxygen (O₂), carbon dioxide, ammonia, phosphate, nitrate. Depending on the type of aquatic environment (not shown, but see, e.g., aquatic environments 108, 208, and 316 of FIGS. 1, 2, and 3, respectively) for which monitoring or testing is being performed using system 400, it may be desirable to test certain combinations of individual parameters. A number of examples of such combinations are described below for various fresh water, saltwater, and brackish water embodiments. It will be understood that those examples are merely illustrative, and that those skilled in the art will understand what parameter(s) and/or combinations of parameters are desirable for a wide variety of applications, such as applications involving various stages of potable water treatment, sewage treatment, etc. Also described below are various examples of chemical indicators and the corresponding parameters they can be used to measure.

In another example, an aquatic environment monitoring apparatus may include a plurality of immobilized chemical indicators supported by a chemical indicator holder. Various holders are discussed further below. Such a chemical indicator holder having a plurality of immobilized chemical indicators can be illuminated by light (e.g., excitation light for fluorescence, reference illumination, etc.) from an optical reader. Various optical readers are also discussed herein. In one example of a chemical holder that can be used with an aquatic environment monitoring system (such as those disclosed herein), a chemical holder (e.g., a discoidal holder) includes a chemical indicator dye sensitive for detecting calcium in the aquatic environment, a chemical indicator dye sensitive for detecting magnesium in the aquatic environment, and a chemical indicator dye sensitive for detecting carbon dioxide in the aquatic environment. In this example each of the chemical indicator dyes are immobilized in an immobilizing medium, such as a cellulosic hydrogel medium. Examples of a chemical indicator dye sensitive for calcium include, but are not limited to, a calcium detecting aminonaphthalimide, a calcium detecting perylenediamide, and any combination thereof. Examples of a chemical indicator dye sensitive for magnesium include, but are not limited to, a magnesium detecting dye based on an aminonaphthalimide, a magnesium detecting dye based on a photon induced electron transfer process (PET), a magnesium detecting dye based on an intramolecular charge transfer process (ICT), a magnesium detecting perylenediamide and any combinations thereof. Examples of a chemical indicator dye sensitive for carbon dioxide include, but are not limited to, a carbon dioxide sensitive dye based on an aminonaphthalimide, a carbon dioxide sensitive dye based on a photon induced electron transfer process (PET), a carbon dioxide sensitive dye based on an intramolecular charge transfer process (ICT), a carbon dioxide sensitive perylenediamide and any combinations thereof.

FIG. 5 illustrates an exemplary arrangement of a chemical indicator 500 on a holder 504 of a chemical indicator

apparatus 508. In this example, chemical indicator 500 is secured to holder 504. With this configuration, chemical indicator 500 is directly exposed to water 512 for which the chemical indicator is designed for use. During use, chemical indicator 500 is illuminated by light 516 from a suitable optical reader 520 and return light 524 is collected therefrom by the optical reader. Chemical indicator 500 can be any one of chemical indicators 412(1) to 412(N) of FIG. 4. FIG. 6 illustrates another exemplary arrangement of a chemical indicator 600 on a holder 604 of a chemical indicator apparatus 608. In this example, chemical indicator 600 is secured to holder 604, which in this example is transparent at least to the wavelength(s) of light necessary for the chemical indicator to be used as an optical indicator. Alternatively, if holder 604 is generally opaque to the relevant wavelength(s), it can be provided with a suitable window 612 that is transparent to the necessary wavelength(s). A light blocking backing 616 that blocks light from the backside 620 of holder 604 is positioned adjacent chemical indicator 600 between the chemical indicator and water 624. Light blocking backing 616 can be porous so as to allow water 624 to reach chemical indicator 600, since the opposite side of the chemical indicator is not in contact with the water because of holder 604 and/or window 612. In one example, light blocking backing 616 can be a light blocking hydrogel, such as a carbon-containing hydrogel. During use, chemical indicator 600 is illuminated by light 628 from a suitable optical reader 632 and return light 636 is collected therefrom by the optical reader. Chemical indicator 600 can be any one of chemical indicators 412(1) to 412(N) of FIG. 4. Referring again to FIG. 4, holder 408 can have any of a wide variety of shapes and can be made of any one or more of a wide variety of materials suitable for a particular application. For example, for a saltwater application, the material(s) should not corrode or otherwise be attacked by the saltwater. Regarding shape, exemplary shapes for holder 408 include, but are not limited to, planar, discoidal, cylindrical, frusto-conical, spherical, ellipsoidal, parallelepiped, etc. Further regarding shape, holder 408 can be made in any suitable form, such as solid (i.e., without openings), fenestrated, trussed, stretched membrane, etc., and can be made as a unitary monolithic part or assembled from two or more discretely manufactured parts. Regarding material(s) of construction, virtually any material(s) can be used. Fundamentally, there is no particular limitation on how holder 408 can be constructed and made.

Water parameter reading system 400 further includes one or more readers 416(1) to 416(M) designed and configured to read the physical change(s) of one or more of chemical indicators 412(1) to 412(N). Some embodiments have a one-to-one correspondence between the number of readers. That is, each chemical indicator 412(1) to 412(N) has a corresponding respective reader 416(1) to 416(M), i.e., $M=N$. In other embodiments, there are fewer readers 416(1) to 416(M) than chemical indicators 412(1) to 412(N), i.e., $M<N$, and in still other embodiments there are multiple readers per chemical indicator, i.e., $M>N$. Any of these embodiments can optionally include one or more mechanisms 420 for moving one or more readers 416(1) to 416(M) relative to chemical indicator apparatus 404, or for moving the chemical indicator apparatus relative to the reader(s), or both. Depending on the configuration of reading system 400 and chemical indicator apparatus 404, the movement that the one or more mechanisms 420 can impart to the driven part (e.g., one of or group of readers 416(1) to 416(M) or

chemical indicator apparatus 404) can be in any one or more of the six degrees of freedom (three linear+three rotational) available for motion.

FIGS. 7A to 7E illustrate five exemplary movement scenarios for readers and chemical indicator apparatuses. Each of these and many other scenarios can be implemented in water parameter reading system of the present disclosure, such as system 400 of FIG. 4. In FIG. 7A, a chemical indicator apparatus 700 includes a rectangular, planar holder 702 supporting twelve chemical indicators 704(1) to 704(12) arranged in a 2x6 array. In this example, a single reader 706 is movable in two linear directions relative to chemical indicator apparatus 700 by a suitable actuator 708 so that the reader can be positioned proximate to each one of chemical indicators 704(1) to 704(12) for reading that chemical indicator. For reasons described in more detail below relative to error minimization, actuator 708 can be designed, configured, and suitably controlled to position reader 706 at multiple positions proximate to each chemical indicator 704(1) to 704(12).

FIG. 7B shows a chemical indicator apparatus 720 that includes a rectangular, planar holder 722 that supports twelve chemical indicators 724(1) to 724(12) arranged in a 3x4 array. In this example, three readers 726(1) to 726(3), corresponding respectively to the three rows of chemical indicators 724(1) to 724(12), are stationary, and chemical indicator apparatus 720 is movable in a single linear dimension relative to the readers by a suitable actuator 728. For reasons described in more detail below relative to error minimization, actuator 728 can be designed, configured, and suitably controlled to position the ones of chemical indicators 724(1) to 724(12) at multiple positions relative to the corresponding respective readers 726(1) to 726(3).

In FIG. 7C, a chemical indicator apparatus 730 includes a discoidal holder 732 that supports four chemical indicators 734(1) to 734(4) arranged annularly about the holder. In this example, a single reader 736 is stationary, and chemical indicator apparatus 730 is rotationally movable about a rotational axis 738 by a suitable actuator 739. For reasons described in more detail below relative to error minimization, actuator 739 can be designed, configured, and suitably controlled to position each chemical indicator 734(1) to 734(4) relative to reader 736.

FIG. 7D illustrates a chemical indicator apparatus 740 that includes a cylindrical holder 742 that supports eight chemical indicators 744(1) to 744(8) arranged on the interior of the holder in two bands of four indicators each. A single reader 746 is provided. To enable single reader 746 to read all eight chemical indicators 744(1) to 744(8), chemical indicator apparatus 740 is rotatable about its central longitudinal axis 748 via a suitable actuator 750, and the reader is movable linearly in a direction parallel to central longitudinal axis 748 via a suitable actuator 752. It is noted that one, the other, or both of actuators 750 and 752 can be actuated to allow reader 746 to be positioned at multiple locations at each of one, some, or all of chemical indicators 744(1) to 744(8).

Referring to FIG. 7E, this figure shows a chemical indicator apparatus 760 that includes a frusto-conical holder 762 that supports twelve chemical indicators 764 (only five of which, i.e., indicators 764(1) to 764(5), are visible) arranged in two bands, one with four indicators and the other with eight indicators. A pair of fixed readers 766(1) and 766(2) are provided, one for reading the upper band and the other for reading the lower band. In this example, a single actuator 768 is provided to rotate chemical indicator apparatus 760 about its central longitudinal axis 770. As with other

examples, if desired actuator **768** can be controlled to provide one position for each reader **766(1)** and **766(2)** relative to the corresponding pair of chemical indicators **764** or multiple positions, for example, for error checking and minimization purposes.

Returning to FIG. **4**, regardless of how chemical indicator apparatus **404** is configured, it can be made to be a consumable product that needs to be replaced from time to time, for example, to avoid undesirable effects of deterioration of the one or more chemical indicators **412(1)** to **412(N)** from interfering with proper readings by any one or more of readers **416(1)** to **416(M)**. It is also noted that the set of chemical indicators **412(1)** to **412(N)** provided on chemical indicator apparatus **404** can vary from instantiation to instantiation. A reason for doing this is to allow the same reader(s) **416(1)** to **416(M)** to be used for differing applications wherein one or more differing parameters and/or one or more ranges within one or more parameters are desired/needed to be determined. Examples of varying chemical indicator sets among instantiations of chemical indicator apparatus **404** are provided below in the context of aquatic-life-supporting aquatic environments, such as aquariums and fish ponds, wherein differing chemical indicator sets are provided for freshwater fish species, saltwater fish species, brackish water species, saltwater coral species, and aquarium cycling/setup due to the differing parameters that are desired and/or necessary to be determined.

Chemical indicator apparatus **404** can be designed and configured to be fully or partially submerged (collectively referred to herein and in the appended claims as “submerged”) in the water (not shown) of the aquatic environment in which water parameter reading system **400** is deployed. It is noted further that the term “submerged” covers not only the cases of full and partial submersion, for example, in an aquarium, aquarium sump, pond, pool, etc., but also the case of exposure of chemical indicator apparatus **404** to the aquatic environment water within inline plumbing. An example of an inline plumbing instantiation of a water parameter reading system is described below.

Depending on the environment in which chemical indicator apparatus **404** is operating, one or more of readers **416(1)** to **416(M)** and/or one or more of chemical indicators **412(1)** to **412(N)** may experience fouling, for example, from algae or other matter building up over time. To combat this fouling, water parameter reading system **400** may include a cleaning system **424** that continuously, intermittently, or periodically cleans critical components of any one or more of readers **416(1)** to **416(M)** and/or chemical indicator apparatus **404**. Examples of cleaning systems that can be used for cleaning system **424** include ultrasound-based cleaning systems, vibration-based cleaning systems, light-based (e.g., UV light to kill organisms) cleaning systems, contact-type (e.g., brush, squeegee, etc.) cleaning systems, and filtered water-jet-based cleaning systems, among others, and any combination thereof. Those skilled in the art will be able to implement, after reading this entire disclosure, any one of these systems given the overall configuration of water parameter reading system and the configuration of interaction of its components in a particular instantiation.

Each of readers **416(1)** to **416(M)** can be any suitable type of reader for the particular one(s) of chemical indicator(s) **412(1)** to **412(N)** that the reader at issue is designed and configured to read. For optically read chemical indicators, for example, chemical indicators in which chemical changes are observable by detecting: the amount of light absorbed, fluoresced upon excitation, and/or reflected and/or the color of light absorbed, fluoresced, and/or reflected, etc., and any

combination thereof, one or more of reader(s) **416(1)** to **416(M)** can be an optical reader capable of detecting such amount(s) and/or color(s). Correspondingly, each reader can include one or more detectors (sensors) **428(1)** to **428(M)** capable of detecting (sensing) the one or more characteristics of the relevant light. As used herein, the term “light” covers electromagnetic radiation in traditional light spectrum, which includes not only visible light, but also infrared (near and far) light, and ultraviolet light. Examples of such optical sensors include, but are not limited to photo-detectors, line cameras, array cameras, charge-coupled device-based sensors, and CMOS-based sensors, among many others. Fundamentally, there are no limitations of the type and configuration of suitable light detectors/sensors as long as they perform the requisite function(s).

Depending on the type(s) and location(s) of detector(s)/sensor(s) **428(1)** to **428(M)** in each reader **416(1)** to **416(M)**, light from the relevant chemical indicator(s) **412(1)** to **412(N)** may need to be collected and/or transmitted from each chemical indicator to the detector(s)/sensor(s). Such collection and/or transmission can be accomplished using any suitable optics **432(1)** to **432(M)**. In addition to conventional optics, for example, optical fibers, lenses, light pipes, etc., any of the unique light conductors disclosed herein can be used for optics **432(1)** to **432(M)**. In embodiments wherein any one of readers **416(1)** to **416(M)** needs to emit light of certain spectral content to illuminate any one or more of chemical indicators **412(1)** to **412(N)**, each of the readers may include one or more suitable light sources **436(1)** to **436(M)** and/or suitable optics **440(1)** to **440(M)** for projecting and/or directing the light from the light source(s) to the appropriate chemical indicator(s). Examples of light sources that can be used for any one or more of light sources **436(1)** to **436(M)** include, but are not limited to, LEDs, lasers, incandescent bulbs or other sources, and any combination thereof. As those skilled in the art will appreciate, each light source **436(1)** to **436(M)** can include one or more light filters (not shown) as needed to create the desired/necessary spectral content. In addition to conventional optics, for example, optical fibers, lenses, light pipes, etc., any of the unique illuminating optics disclosed herein can be used for optics **440(1)** to **440(M)**. In some embodiments wherein both collection and illumination optics **432(1)** to **432(M)** and **440(1)** to **440(M)** are used in a reader, they can be combined as taught below, for example, in the context of combined illuminators/light collectors **1604** and **1800** of FIGS. **16** and **18**, respectively.

Water parameter reading system **400** may include a processing system **444** that includes one or more processors for controlling the overall operations of the system and implementing whichever of the above-described and other functionalities that a designer chooses to embody in the system. For example, processing system **444** can control each of readers **416(1)** to **416(M)**, mechanism(s) **420** for moving the reader(s) and/or chemical indicator apparatus **404**, one or more displays **448**, cleaning system **424**, one or more communications devices **452**, and/or one or more user interfaces **456**, among other things, as may be present. Exemplary processors that can be used for each of the one or more processors in processing system **444** include, but are not limited to, an application specific integrated circuit, a microprocessor, a system on chip, etc. Processing system **444** is in communications with one or more memories (collectively represented by memory **460**), which can comprise any one or more types of memories, including, but not limited to, cache memory, random-access memory (RAM) (such as dynamic RAM and/or static RAM), read-only

memory, removable hardware storage media (such as magnetic storage devices, optical storage device, flash-memory devices, etc.). Memory **460** can contain suitable machine-executable instructions **464** executable by processing system **444** to perform any one or more of the functionalities imparted into water parameter reading system **400**.

Each display **448** can be any type of display desired to present one or more outputs to a user and, in some cases, such as with video displays, receive one or more inputs from a user. Examples of displays that can be implemented include, but are not limited to, video displays (such as flat panel video displays (LCD, LED, etc.) and CRT video displays, touchscreen or not), indicator light displays, audio displays, gauges, and non-video flat panel displays (e.g., LCD and LED panels, touchscreen or not), among many others. Fundamentally, there is no limitation on the type(s) of display(s) **448** that can be used in water parameter reading system **400**. Similarly, each user interface **456** can be any suitable type of user interface, such as hard and soft user interfaces implemented via software and hardware. Fundamentally, there is no limitation on the type(s) of user interface(s) **456** that can be used in water parameter reading system **400**. Each communications device **2252** can be any communications device that is desired to be used to provide water parameter reading system **400**, and can be a wired device, such as wired communications port (e.g., universal serial bus port, FIREWIRE® port, HDMI port, RCA jack port, etc.) or can be a wireless transmitter, receiver, or transceiver based on radio-frequency communications (e.g., an IEEE 802.11 standard device and a cellular telecommunications device), on microwave communications, on ultrasonic communications, on optical communications (e.g., an infrared device), or on magnetic communications (e.g., an inductively coupled device), among others. Fundamentally, there is no limitation on the type(s) of communications device(s) **452** that can be used in water parameter reading system **400**. Examples of various ones of the components of water parameter reading system **400** are provided below in connection with presentations of several exemplary embodiments of aquatic environment monitoring/measuring systems.

Exemplary Aquarium Monitoring System

FIG. **8** illustrates an exemplary aquarium monitoring system **800** designed and configured to continually monitor a number of parameters of water **804** within an aquatic environment having a component **808**, such as an aquarium or aquarium sump, that contains at least a portion of the water being monitored. In this example, system **800** includes a monitoring unit **812** at least partially submerged in water **804**, and monitors, according to user designated control parameters, the ecological conditions of the aquatic environment by continually reading a plurality of water parameters of interest. Monitoring unit **812** removably receives a chemical indicator apparatus, hereafter referred to as “chemical indicator disc **816**,” that, as described below, includes a plurality of chemical indicators (not shown) that, as described above, each undergo detectable physical changes with changes in the level of certain constituents of water **804**. It is noted that while the term “disc” is appropriate for chemical indicator apparatus **816** due to its discoidal shape, for the purpose of the present disclosure and the appended claims, the term “wheel,” when referring to a chemical indicator apparatus, shall mean any chemical indicator apparatus that is rotated by a monitoring/measurement unit, water parameter reading system, or other measurement and/or monitor device disclosed herein about a rotational axis and that resembles a wheel. For example, chemical

indicator disc **816** is a wheel, as are chemical indicator apparatuses **7E30** of FIG. **7E**, **1916** of FIG. **19**, **2508** of FIG. **25**, **4100** of FIGS. **41**, and **4412** of FIG. **44**. Chemical indicator disc **816** is described below in detail.

Exemplary monitoring unit **812** communicates the ecological conditions, here wirelessly via an onboard antenna **820** (in this example an above-water antenna, but a submersible antenna could be used), to a wireless communications device, such as a WIFI™ router **824**, via any suitable communications protocol, here an IEEE 802.11 protocol. Router **824** is connected to a communications network **828**, for example, a global communications network such as the Internet, via a suitable connection **832**. Connection **832** to communication network **F28** enables access to a cloud computing platform **836**, which can, among other things, store data **840** from monitoring unit **812**, run analyses on such data, provide a web-based GUI **844** for the display of raw, processed, and/or analyzed forms of the data, provide a web-based GUI **848** for allowing a user to control the monitoring unit, provide raw, processed, and/or analyzed forms of the data to a remote device **852**, such as a computing device, (e.g., smartphone, tablet computer, laptop computer, desktop computer, etc.), and control one or more applications.

FIG. **9** depicts monitoring unit **812** and chemical indicator disc **816** in more detail. During use, monitoring unit **812** receives replaceable chemical indicator disc **816** on a shaft-type receiver **900** so that the disc is able to rotate about its central rotational axis **904**. As described below, during operation, monitoring unit **812** can, as desired or not, rotate chemical indicator disc **816** about rotational axis **904** for a number of reasons, including for taking readings of the chemical indicators (not shown), for causing water in the space between the disc and the monitoring unit to exchange for water outside that space to expose the chemical indicators to “fresh” water, and for self-cleaning purposes. Chemical indicator disc **816** is positioned overtop one or more reader ports, in this example, optical reader ports **908(1)** and **908(2)** and an ultraviolet (UV) light port **912**. As described in detail below, optical reader ports **908(1)** and **908(2)** allow optical readers (not shown) onboard monitoring unit **812** to optically read the chemical indicators onboard chemical indicator disc **816**, and UV light port **912** is provided for sterilizing any biological material that might attach to the disc. As mentioned, monitoring unit **812** has one or more antennas **820**, each of which is preferably, though not necessarily, mounted internally and/or externally, and/or mounted at the top of the unit and to keep the antenna(s) out of water for best reception and transmission. In one example, monitoring unit **812** is designed so that the top portion of the unit above water line **920** is above water and the lower portion of the unit below water line **920** is submerged during use.

In one embodiment, monitoring unit **812** and corresponding chemical indicator disc **816** are designed and manufactured to have a weight that is close to the weight of the water displaced by the unit and disc when they are installed in the water wherein they will be used. In an embodiment that is engaged with a wall of an aquarium or other container via magnetic coupling with a magnetic device on the exterior of the aquarium or other container (such as described below), it is beneficial to have the combined weight of monitoring unit **812** and disc **816** and the displaced water be close to one another so that the unit (with disc attached) do not tend to slide up or down along the engaged wall. In addition, smaller holding magnets can be used. In addition, if the combined weight of monitoring unit **812** and disc **816** is slightly less

than the weight of the displaced water, then if the unit does disengage from the wall, then it will not sink so that it can be easily reached by a user. Monitoring unit **812** can include a 3-axis accelerometer (such as accelerometer **2276** of monitoring unit **2202** of FIG. **22**), and this accelerometer can be used to detect abnormal movement (tilting, vertical slipping, and/or rotation, etc.) of the unit that indicates disengagement with the wall or other undesirable movement. In one example, the combined weight of monitoring unit **812** and disc **816** is about 220 g, whereas the weight of the water displaced by them in their normal operating location is about 240 g.

Chemical indicator disc **816** includes an optional filter **924** that covers flow passages in the disc, here four flow passages **928(1)** to **928(4)** that allows water to flow from one side of the disc to the other. While four flow passages **928(1)** to **928(4)** are shown, more or fewer passages can be provided to suit a particular design. Each flow passage **928(1)** to **928(4)** can be enhanced with one or more features that assist the flow of water therethrough when disc **816** is being rotated by monitoring unit **812**. For example, when monitoring unit **812** is rotating disc **816** in a counterclockwise direction when looking toward the monitoring unit along rotational axis **904**, the flow assisting feature(s) of each flow passage **928(1)** to **928(4)** can pull water into the space between the disc and monitoring unit. In this example, filter **924** is used to filter the water being pulled into that space. This can be beneficial to reducing the amount of light-scattering particulate and/or other matter in the water present in that space during measurement readings, which in turn can increase the accuracy of the readings. In one scenario, monitoring unit **812** can be programmed to perform a flush cycle in which it spins disc **816** for a predetermined amount of time and a predetermined speed (and direction) sufficient to pull water into the space between the disc and the monitoring unit just prior to taking one or more measurement readings. Since the water being pulled in is being filtered by filter **924**, during the immediately subsequent reading(s) the water in that space is as clean as practicable. It is noted that flushing can also be beneficial in embodiments not including any filters (such as filter **924**) and that one or more filters are useful outside the context of flushing.

FIG. **10** illustrates exemplary chemical indicator disc **816** in more detail than depicted in FIGS. **8** and **9**. As seen in FIG. **10**, disc **816** comprises a generally discoidal holder **1000**, which, in this example, holds ten chemical indicators, here in the form of indicator patches **1004(1)** to **1004(10)** that are arranged in an annular manner about disc **816** and contain various dyes. It is noted that although ten chemical indicators **1004(1)** to **1004(10)** are shown, in other embodiments disc **816** or similar disc can have more or fewer indicators as needed and/or desired to suit a particular application. In this example, each indicator patch **1004(1)** to **1004(10)** is gel-based and contains a dye that either changes in its light absorbance or its fluorescence, or both, as a function of the amount of one or more particular constituents of the water to which the patches are exposed, such as water **804** of FIG. **8**. Also in this example, the dyes contained in indicator patches **1004(1)** to **1004(10)** are selected for testing saltwater and are as follows: patch **1004(1)** contains a magnesium indicator dye; patch **1004(2)** contains a calcium indicator dye; patch **1004(3)** contains a phosphate indicator dye; patch **1004(4)** contains a nitrate indicator dye; patch **1004(5)** contains a nitrite indicator dye; patch **1004(6)** contains a pH indicator dye (Type 1); patch **1004(7)** contains a pH indicator dye (Type 2); patch **1004(8)** contains an ammonia indicator dye; patch **1004(9)** contains a dissolved

oxygen indicator dye; and patch **1004(10)** contains a sensor age dye. Disc **816** also includes a black reflectance patch **1008** and a white calibration reference patch **1012** for calibrating the readers (not shown) onboard monitoring unit **812** (see, e.g., FIG. **9**). It is important to note that the sensing indicators of disc **816** have reversible reactions to the constituents of the water whereby if the concentration of a constituent goes back down to a base level, the sensor dye returns to its original state.

In the particular embodiment shown, each of patches **1004(1)** to **1004(10)**, **1008**, and **1012** is located in a corresponding recess **1016(1)** to **1016(12)**. However, in other embodiments, this need not be the case. For example, depending on the thickness of a particular dye patch it may not reside in a recess, but rather be applied to a non-recessed surface of disc **816**. Indeed, in some embodiments, disc **816** may have a completely flat surface in the patch region and all of patches **1004(1)** to **1004(10)**, **1008**, and **1012** may be secured to that surface. In addition, it is noted that while patches **1004(1)** to **1004(10)**, **1008**, and **1012** are shown as discrete bodies relative to one another, in other embodiments this need not be so. For example, all of patches **1004(1)** to **1004(10)**, **1008**, and **1012** can be provided as a unitary structure, such as on an annular substrate to which the various patches are provided. Then, during manufacture, such preformed annular structure can simply be adhered or otherwise secured to holder **1000**. In addition, patches **1004(1)** to **1004(10)**, **1008**, and **1012** need not necessarily be spaced from one another. On the contrary, for example, adjacent ones of patches **1004(1)** to **1004(10)**, **1008**, and **1012** can directly abut one another. It should be noted that while FIG. **8** shows patches with rounded ends, it is preferred but not required to use more rectangular shapes such as shown in FIG. **19** for more efficient use of the space and more optically readable surface area.

Still referring to FIG. **10**, the illustrated example of chemical indicator disc **816** includes an information storage device, here a radio-frequency identification (RFID) based integrated circuit (IC) storage device **1020** that can be used to store a variety of information, such as calibration and manufacturing data sets for various ones of indicator patches **1004(1)** to **1004(10)**, disc identification data, disc usage data, and an authentication key to thwart counterfeiting of the disc. As seen below, monitoring unit **812** (see, e.g., FIG. **9**) may include a corresponding RFID device (not shown) for reading and/or writing information from or to RFID storage device **1020**. While an RFID tag based storage device is shown, other forms of storage devices can be used to store various information, such as some or all of the information noted above. Other forms of storage devices include bar code devices, QR code devices, and magnetic storage, among others. It is noted that in some embodiments, information and data indicated above as being storable on disc **816** can be stored in another location, such as on a monitoring unit or one or more network storage devices, such as one or more web servers, among other locations.

In the embodiment shown in FIG. **10**, chemical indicator disc **816** is held in engagement with monitoring unit **812** (see, e.g., FIG. **9**) using magnetic coupling between, in this example, a pair of permanent magnets **1024(1)** and **1024(2)** on the disc and a corresponding pair of magnets (**KK28(1)** and **1328(2)**) in FIG. **13**) inside the monitoring unit. As described below in more detail, this magnetic coupling not only holds disc **816** in engagement with monitoring unit **812**, the monitoring unit also uses this magnetic coupling to align the disc and rotate it about rotational axis **904** during use. In some embodiments of aquarium monitoring system **800**

(FIG. 8), inhibiting extraneous light from reaching patches 1004(1) to 1004(10), 1008, and 1012 (FIG. 10) to promote the accuracy of the readings is very important. Consequently, disc 816 is provided with a light-blocking feature, here, an apron 1026, that works in conjunction with a cooperating light blocking feature on monitoring unit 812, which as seen in FIG. 9 is a flange 932 shaped similarly to apron 1026 on the disc, as seen in FIG. 10.

Referring again to FIG. 10, as mentioned above chemical indicator disc 816 includes a plurality of flow passages 928(1) to 928(4) having chamfered surfaces 1028(1) to H28(4) that promote the flow of water into the space between the disc and monitoring unit 812 (see, e.g., FIG. 9) during operation to enable the water to transport from one side of the disc to the other side of the disc by way of pressure differentials created by the chamfered edges. Disc 816 also includes an engagement structure, here, a frusto-conically shaped receptacle 1032 designed and configured to be conformally engaged with receiver 900 (FIG. 9) on monitoring unit 816 (also FIG. 9). In some embodiments, receiver 900 (FIG. 9) and receptacle 1032 (FIG. 10) must be designed with some care because it can be very important to have a tight fit to minimize wobble of disc 816 relative to monitoring unit 812 (see, e.g., FIG. 9) but to also allow for relatively friction-free rotation of the disc during operation. Receptacle 1032 may be provided with one or more grooves or other pressure-relieve structure (e.g., aperture) that allows water to flow out of the receptacle as disc 816 is engaged onto receiver 900 (FIG. 9). In addition, receiver 900 and the walls of receptacle 1032 may be at least partially composed of, for example, by impregnation, a relatively low friction material, such as polytetrafluoroethylene, that reduces the friction between the contacting parts to inhibit wear. In some embodiments (see below) receiver 900 (FIG. 9) may be made at least partially of an electrically conductive material and the walls of receptacle 1032 (FIG. 10) may correspondingly have a conductive contact 1036 for conducting electrical charge, for example, to one or more electrodes (one electrode 1100 shown for convenience) onboard disc 816, as shown in FIG. 11.

In FIG. 11, the illustrated embodiment of chemical indicator disc 816 is augmented with electrode 1100 mounted on the “back” side 1104 of the disc, i.e., the side of the disc opposite the side that confronts monitoring unit 812 (see, e.g., FIG. 9) during operation. Electrode 1100 is provided to modify (e.g., extend) the dynamic range of one of chemical indicator patches 1004(1) to 1004(10) (FIG. 10) located on the obverse side of disc 816 opposite the electrode. Referring now to FIG. 11, and also to FIG. 12, when a voltage source 1200 (FIG. 12) within monitoring unit 812 generates a voltage, electrode 1100 (FIGS. 11 and 12), in conjunction with a second electrode 1204 in contact with water 804, creates a current flow within the water being tested. When a positive potential is applied, for example, to electrode 1100 relative to electrode 1204, the chemical cations (not shown) are repelled away from the one of chemical indicator patches 1004(1) to 1004(10) (FIG. 10) beneath electrode 1100. This reduction of the chemical ions near the affected chemical patch 1004(1) to 1004(10) lowers the response of the dye in that patch. As those skilled in the art will readily understand, using proper calibration of voltage and/or currents, this lowering of the response can be used to effectively extend the range of the affected patch 1004(1) to 1004(10). It should also be noted that the reverse polarity can also be used to attract ions and therefore increase the sensitivity. Pulses of electric charge on 1100 can be used to modulate the optical

response of a sensor patch over a very short period of time so that no long term voltage or current is required.

As noted above, a magnetic coupling is used to hold chemical indicator disc 816 (see, e.g., FIG. 9) into engagement with monitoring unit 812 and to allow the monitoring unit to rotate the disc during operation. FIG. 13 illustrates this magnetic coupling, as well as a number of other features. Referring to FIG. 13, monitoring unit 812 includes a wall 1300 that is part of a waterproof enclosure 1304 that keeps the interior 1308 of the monitoring unit and its contents dry. Receiver 900 is fixedly secured to wall 1300 and in FIG. 13 is shown fully engaged by disc 816. A rotary motor 1312, such as a finely controllable electrical stepper motor, is fixedly mounted within interior 1308 of monitoring unit 812 so that its rotational axis 1316 is coincident with rotational axis 904 of the disc. In this example, motor 1312 has a central rotating shaft 1320 that rotates about rotational axis 1316 and has a support bar 1324 fixedly secured at the end thereof. Magnets 1328(1) and 1328(2) are fixedly secured to support bar 1324 and are movable therewith when motor 1312 rotates shaft 1320. It is noted that while a direct-drive arrangement is shown, those skilled in the art will understand that a transmission, such as a reducing transmission, can be used, especially if it is desired to control the rotation of disc more finely than motor 1312 is directly capable of.

As can be readily appreciated, when opposing pairs of magnets 1328(1), 1328(2), 1024(1), and 1024(2) are of opposing polarities, those pairs attract one another. Thus, chemical indicator disc 816 is magnetically pulled into fully seated engagement with receiver 900. In addition, when motor 1312 rotates support bar 1324, thereby moving the magnets, the magnetic attraction of magnets 1024(1) and 1024(2) to the moving magnets 1328(1) and 1328(2), respectively, causes disc 816 to rotate in virtual unison with the rotating support bar. It is noted that while two pairs of magnets 1328(1), 1328(2), 1024(1), and 1024(2) are illustrated, more or fewer magnets can be used. Regarding the number of magnets provided, it is noted that in some embodiments the number and strength of the magnets need to be carefully selected, as too powerful and/or too many magnets can cause too much friction between disc 816 and monitoring unit 812. If permanent magnets are used, the magnetic force used to hold disc 816 onto receiver 900 should be low enough such that a user can freely remove the disc when it's no longer providing a proper operation. If, for example, electromagnets or other switchable magnets are used, the magnetic coupling may be turned off for disc removal. The magnetic force should also be sufficient to ensure water flow and turbulence against disc 816 will not dislodge it from receiver 900.

The present inventor has determined that the shapes of magnets 1328(1), 1328(2), 1024(1), and 1024(2) can have an impact on the performance of the magnetic coupling, especially in the imparting of motion to disc 816. For example, if magnets 1328(1), 1328(2), 1024(1), and 1024(2) are flat discoidal magnets, i.e., have relative large diameters relative to their thicknesses, or are wide magnets of another shape having expansive faces and they are placed so that their expansive faces face one another, the magnetic interaction between the magnets is relatively sloppy, i.e., there is a relatively large amount of play in the alignment. On the other hand, if opposing ones of magnets 1328(1), 1328(2), 1024(1), and 1024(2) are too narrow, when the narrow ends are made to face one another, the magnets can too easily lose their magnetic coupling. FIG. 14 is a graph 1400 illustrating the amount of rotational pull necessary to pull a magnet-

cally coupled rotating body (such as disc **816** of FIGS. **8** and **9**) in either direction of rotation based on the size of the magnets used (e.g., magnets **1328(1)**, **1328(2)**, **1024(1)**, and **1024(2)**) and offset angle between the magnets on the opposite sides of the magnetic coupling. The pull is illustrated for three sizes of magnets, $\frac{3}{16} \times \frac{1}{16}$ " (curve **1404**), $\frac{1}{4} \times \frac{1}{16}$ " (curve **1408**), and $\frac{1}{8} \times \frac{1}{8}$ " (curve **1412**). At zero offset, the magnets are in near perfect alignment and there is no net pull in either direction (clockwise and counterclockwise). Once rotation of the driving set of magnets is started, they will start to pull via the fields of the driven magnets illustrated in FIG. **14**. For the $\frac{1}{8} \times \frac{1}{8}$ " magnets of curve **1412**, the maximum force is obtained at an offset of about 10° . However, in the example of disk **816** and monitoring unit **812** of FIGS. **8** and **9**, the friction is low enough that the lag will rarely ever exceed 1° to 2° . In a specific example of magnets **1328(1)**, **1328(2)**, **1024(1)**, and **1024(2)**, with disc **816** having a diameter of 38 mm, a mass of about 20 g, and a gap of about 2.3 mm between opposing magnets, a Neodymium cylindrical magnet having about a 3.1 mm diameter and a 3.1 mm length has been found to be satisfactory when the circular ends of the opposing magnets are oriented to face one another. Within a certain range, if the gap is large, the diameter can remain constant and the length increased to provide additional magnetic strength. Oppositely, if the gap is smaller, the diameter can remain constant, but the length decreased to provide lesser magnetic strength.

FIG. **13** also illustrates a portion of one of the optical readers mentioned above, that detects one or more optical characteristics and changes in the characteristic(s) in the dye(s) of one or more of chemical indicator patches, only two of which, i.e., patches **1004(1)** and **1004(6)**, are depicted in FIG. **13**. The portion of the optical reader illustrated is a combined illuminator/light collector (I/LC) **1332** that is used to illuminate each one of chemical indicator patches **1004(1)** to **1004(10)** (FIG. **10**) that the reader is designed and configured to read, such as patch **1004(1)** shown in FIG. **13**, and to collect light that reflects and/or emanates (e.g., fluoresces) from that patch as a result of the illumination. Because of the nature of the dyes in the one(s) of chemical indicator patches **1004(1)** to **1004(10)** (FIG. **10**), the amount of light collected by combined I/LC **1332** from each patch is indicative of the level of constituent(s) of water **804** that that patch is designed to measure. Several examples of combined I/LCs suitable for use as combined I/LC **1332** are described below in detail. However, before proceeding to those descriptions, it is noted that in this example, combined I/LC **1332** extends through port **908(1)** in wall **1300** and forms a liquid seal therewith to keep water **804** out of interior **1308** of monitoring unit **816**. It is noted that the other port in this example, i.e., port **908(2)**, is occupied by a second combined I/LC (not shown) that is identical to combined I/LC **1332**.

FIG. **16** illustrates combined I/LC **1600** that can be used for combined I/LC **1332** of monitoring unit **812** shown in FIG. **13** or, for example, in any other suitable embodiment of a monitoring unit made in accordance with the present disclosure. As seen in FIG. **16**, combined I/LC **1600** comprises a unitary monolithic body **1604** formed from one or more translucent materials, such as acrylic plastic, polycarbonate plastic, glass, sapphire, etc. In one example, when made of a moldable material, monolithic body **1604** can be molded, with little to no subsequent machining or other processing. Combined I/LC **1600** includes spot lensing **1608** and a light pipe **1612**. Spot lensing **1608** is designed and configured to project individual spots of light, here, two spots **1616(1)** and **1616(2)** of light **1620(1)** and **1620(2)**,

onto chemical indicator disc **816** (i.e., the target), wherein each spot projected is based on light emitted from a corresponding light source, here, light sources **1624(1)** and **1624(2)**, respectively. In a particular embodiment described below in connection with FIGS. **25** and **26**, spot lensing similar to lensing **1608** is used to project four spots of light onto the corresponding chemical indicator apparatus, two spots for reflectivity measurements and two spots for fluorescence or absorbance measurements.

In one implementation spot lensing **1608** is carefully designed and configured in conjunction with the spacing, *S*, between combined I/LC **1600** and the surface **1626** of disc **816** to provide highly precisely sized and located spots **1616(1)** and **1616(2)**. As seen in FIG. **16**, spot lensing **1608** is designed and configured so that light **1620(1)** and **1620(2)** passing by a principal point at spot lensing converges at a focal point **1628** that is located at a distance beyond the target (chemical indicator disc **816**) so that the light forms the two individual spots **1616(1)** and **1616(2)** on the target. In one example, wherein spacing *S* is about 3.5 mm, the focal distance *F* to focal point **1628** is about 7.8 mm. In addition, it is noted that spot lensing **1608** is further designed to provide very little to no variance in measurements acquired over a relatively wide range of spacing *S*. In other words, the amount of light collected by combined I/LC **1600** remains largely unchanged despite spacing *S* varying due to wobble and/or other factors. This is illustrated, for example, in the graph **1700** of FIG. **17**, which shows that there is no more than about 1% variance in measurements over a range of almost 2.0 mm. In graph **1700** of FIG. **17**, curve **1704** represents the detected intensity, as a percentage of the maximum intensity, of an illumination spot formed by a combined I/LC similar to combined I/LC **1600** of FIG. **16** using a red LED input. Curve **1708** is a similar curve, but for fluorescent light detected from a spot illuminated using a light of an appropriate excitation wavelength for the particular chemical indicator used. Curve **1712** represents the ratio of $(R/R_m)/(F/F_m)$ where *R* is reflectivity reading and *R_m* is maximum Reflectivity reading, *F* is fluorescence reading and *F_m* is maximum fluorescence reading. As can be seen from graph **1700**, curve **1712** reveals that no more than about 1% variation in intensity occurs over a range **1716** of almost 2.0 mm when using this ratiometric correction step. It should be noted that any number of different wavelengths of light could be used to create this reflectance signal used for correction.

Referring again to FIG. **16**, the relative wide range distance *S* having low intensity variation can be important to the quality of results provided by monitoring unit **812** when there is variance in distance *S* from reading to reading, for example, due to things like wobble of disc **816** due to movement of water **804**, such as from a wave generator, fish swimming by, etc. In addition, it is noted that the relatively wide range of allowable error for spacing *S* allows a designer to carefully choose the size of illumination spots **1616(1)** and **1616(2)** to control the amount of photo-aging of the particular chemical indicator at issue. Photo-aging of chemical indicators is addressed below in more detail, but generally, the lower the brightness of the illumination, the slower the photo-aging. Thus, by making illumination spots **1616(1)** and **1616(2)** relatively large, the intensity of the brightness at any location within that spot is lower than if the same light **1620(1)** and **1620(2)** were used to form a smaller spot, which would be of greater brightness intensity. That would be the case if the target (disc **816**) were moved closer to focal point **1628**, thereby increasing spacing *S*. That said, over a certain optimal range, despite differences in spacing

S, largely the same amount of light is collected from a more-intense smaller spot as is collected from a less-intense larger spot. When spacing S is selected to be in this optimal range, substantial immunity to negative effects of disc wobble and other inaccuracies in spacing S and minimizing photo-aging can be readily accounted for.

FIG. 15 is a diagram illustrating considerations that can be used to design a combined I/LC of the present disclosure. As seen in FIG. 15, which illustrates an I/LC 1500 and a target 1504 spaced from the I/LC by distance (spacing) S to an upper portion 1508 of a light collector 1512 that collects light from the target in the manner described above relative to I/LC 1604 of FIG. 16. FIG. 15 also illustrates spot lensing 1516 of I/LC 1500, a light source 1520, a light detector 1524, and an optional light filter 1528. It is noted that each of light source 1520, light detector 1524, and filter 1528 can be the same as or similar to any of the like items described herein. As seen in FIG. 15, the light emitted by light source 1520 is represented by three rays 1532, 1536, and 1540, which represent, respectively, the inside half-brightness flux line, the full brightness flux line, and the outside half-brightness flux line. The light from light source 1520 that is directed onto target 1504 by spot lensing 1516 forms a spot 1544 of light having points 1548 and 1552 that are the outside and inside half-brightness points, respectively. An angle 1556 is the critical angle for the interface of the material of light collector 1512 and air (which here laterally surrounds the light collector). In the present example, wherein light collector 1512 is made of acrylic, critical angle 1556 is 42.5°. The ray 1560 leading to critical angle 1556 indicates the angle that is the minimum for the light to be reflected onto detector 1524. Any ray that is less than critical angle 1556 will pass through the side wall 1564 of light collector 1512 and will not reach the detector.

As distance S is increased, the quantity of rays emanating from between outside half-angle point 1548 and inside half-angle point 1552 of spot 1544 that will exceed critical angle 1556 such that they will be directed onto detector 1524 goes up. When the distance S increases, the distance from target 1504 to the aperture formed by the internal TIR center column also increases and therefore results in a reduction of intensity as a function of $1/S^2$. So by balancing the rate in which the rays become less intense due to distance with the rate at which the rays start passing through the sides of light collector 1512 at less than critical angle 1556, a peak detection point can be formed at a desired height with spots 1544 at useful distances from the centerline 1568 of I/LC 1500. By adjusting the angle of side walls 1564 of light collector 1512 relative to centerline 1568, distance S at which the peak light collection occurs can be tuned. The rate at which the light falls off as a function of distance S change can also be tuned by way of changing whether rays inside and outside half-brightness rays 1532 and 1540 are divergent or convergent as they leave spot lensing 1516 of I/LC 1500. This effectively defines a band of useful operation.

Referring again to FIG. 16, spot lensing 1608 includes a light-entrance surface 1632 that has a high curvature due to the interface of the material of body 1604 with air between light sources 1624(1) and 1624(2) and the need to impart a significant amount of refraction into light 1620(1) and 1620(2) as it proceeds through the spot lensing. In this example, this need is relatively great because the output surface 1636 of spot lensing 1608 interfaces with water, which will typically have an index of refraction that is relatively close to the index of refraction of the material of body 1604 such that little refraction is achievable at surface 1636 without exceedingly drastic curvatures that interfere

with other functionality of combined I/LC 1600. It is noted that spot lensing 1608 can be continuous around central light pipe 1612, or not. As an example of the latter, spot lensing 1608 can be notched so that lensing is present only at each light source 1624(1) and 1624(2) and not present therebetween. It is also noted that spot lensing can be provided with one or more contour features at and/or adjacent output surface 1636 that inhibits internal reflection, both partial and total, back into light pipe 1612. Indeed, in the example shown, the curvature at output surface 1636 is configured to direct light coming from light source 1624(2) to pass over-top of light pipe 1612 into spot lensing 1608 on the other side of the light pipe so that it outputs through light-entrance surface 1632 for the opposite light source 1624(1), thereby keeping the stray light from reaching the light pipe and, ultimately, sensor 1660.

In this embodiment, combined I/LC 1600 includes optional laterally dispersive lensing 1640 that acts to direct portions 1644(1) and 1644(2) of the light 1620(1) and 1620(2), respectively, emitted from light sources 1624(1) and 1624(2) away from spots 1616(1) and 1616(2). Directing portions 1644(1) and 1644(2) away from spots 1616(1) and 1616(2), and more generally from the region where light is to be collected by combined I/LC 1600, those portions do not interfere with the readings taken by a reader system, such as reader system 400 of FIG. 4. Those skilled in the art will readily understand how to design laterally dispersive lensing 1640.

Each light source 1624(1) and 1624(2) can be any suitable source, including filtered and unfiltered monochromatic and multiband light-emitting diodes (LEDs), filtered and unfiltered monochromatic and multiband lasers, filtered and unfiltered incandescent sources, filtered and unfiltered optic fiber(s) in optical communication with a light emitter, etc. Those skilled in the art will understand how to select the proper light source(s) and any optical filter(s) necessary to achieve the desired results. Some examples of specific light sources are described below.

As for the light collection aspect, combined I/LC 1600 includes central light pipe 1612 that collects light 1648(1) and 1648(2) from the regions of spots 1616(1) and 1616(2), respectively. As should be apparent from the foregoing discussion, light 1648(1) and 1648(2) can be reflected light from spots 1616(1) and 1616(2) or fluorescent light resulting from the stimulation of any fluorescent dye, for example, from any one of chemical indicator patches 1004(1) to 1004(10) (FIG. 10) that includes such dye, from spots 1616(1) and 1616(2), or a combination of both. Central light pipe 1612 include an input end 1652 proximate to chemical indicator disc 816 (when present) and an output end 1656 that directs light 1648(1) and 1648(2) toward one or more suitable sensors 1660, which may or may not be located downstream of one or more optional light filters 1664, depending on the sensitivity(ies) of the sensor(s) provided. For example, for a fluorescing dye, it is typically desirable to measure (sense) only the fluorescent light, i.e., without any reflected stimulating light. If the sensor 1660 at issue is a broadband sensor, then it would be desirable to provide one or more filters 1664 that filter out the original stimulating light. Alternatively, if the sensor 1660 at issue is sensitive only to the fluorescent light, then a filter is not needed. It is noted that light pipe 1612 can have any length desired. In such cases, any losses can be accounted for. In this connection, in some embodiments light pipe 1612 can be segmentized, as long as the segments are properly optically coupled. It should also be noted that filters such as

evaporated coating dielectric layer filters and other types can be coated onto output end **1656** and become an integral part of the I/LC.

Light pipe **1612** and combined I/LC **1600** more generally include several features to ensure that the light **1648(1)** and **1648(2)** collected by the light pipe and directed toward sensor(s) **1660** is substantially only light from the target, i.e., chemical indicator disc **816**. These features include: the separation of light pipe **1612** from spot lensing **1608** along a portion of the light pipe; the design (curvatures) of entrance and output surfaces **1632** and **1636**, respectively, that inhibits internal reflection from spot lensing into light pipe within body **1604**; the provision of laterally dispersive lensing **1640**; and the design of lateral surface **1668** of the spot lensing that also help inhibit internal reflections from reaching the light pipe. Sensor **1660** can be a surface mounted detector on the bottom side of a printed circuit board (PCB) with a sensing area that collects light through a hole in the PCB. Light sources **1624(1)** and **1624(2)** can also be surfaces mounted but on the opposite side of the PCB from sensor **1660**. This arrangement permits the use of the PCB material to act as a light block for making sure light that is internally scattered from light sources **1624(1)** and **1624(2)** can't make direct optical path to sensor **1660**.

In the example shown, each light source **1624(1)** and **1624(2)** comprises a lensed LED package and is located in close proximity to light-entrance surface **1632** of spot lensing **1608**. In one example, each light source **1624(1)** and **1624(2)** output light having a beam angle β of about 10° to about 30° . As used herein and in the appended claims, the term "beam angle" shall mean the angle between the two directions opposed to each other over the beam axis for which the luminous intensity is half that of the maximum luminous intensity of the output of the light source at issue. Depending on the configuration of the reader of which combined I/LC **1600** is part, light sources **1624(1)** and **1624(2)** can have the same output wavelength(s), or, alternatively, the respective output wavelength(s) can differ from one another. This will become apparent with an exemplary embodiment described below that has four light sources per reader, two light sources for measurement purposes (e.g., either fluorescence or absorbance) and two light sources for determining whether or not there are any contaminants on the target (disc **816**) where measurement readings are being taken that might interfere with the resulting measurements. In addition, it is noted that depending on the spectral output of each light source **1624(1)** and **1624(2)**, one, the other, or both can be provided with one or more light filters **1672(1)** and **1672(2)**, respectively, as needed to suit the needs of use.

Whereas FIG. **16** illustrates an example in which combined I/LC **1600** is made in a unitary monolithic manner, FIG. **18** illustrates an alternative combined I/LC **1800** that is an assembly of multiple separately manufactured parts. Like combined I/LC **1600** of FIG. **16**, combined I/LC **1800** of FIG. **18** includes spot lensing **1804** and a central light pipe **1808**, each having the same functionality described above for like portions of combined I/LC **1600** of FIG. **16**. However, in FIG. **18**, light pipe **1808** is formed as a separate component relative to spot lensing **1804**. The two components, i.e., light pipe **1808** and spot lensing **1804** are held together, for example, by press fit, with an intermediate sleeve **1812** that separates the light pipe and spot lensing. Intermediate sleeve **1812** is made of any suitable material, such as an opaque material, highly reflective (e.g., mirror-like) material, or a material having an index of refraction suitably different from the materials of light pipe **1808** and spot lensing **1804** such that light internal to each of the light

pipe and spot lensing is inhibited from reaching the other component. It is noted that in this example, laterally dispersive lensing (e.g., like laterally dispersive lensing **1640** of combined I/LC **1600** of FIG. **16**) is not present. However, in alternative embodiments it can be provided, for example, in a unitary monolithic manner with spot lensing **1804**.

FIG. **19** illustrates an alternative chemical indicator disc **1900** that can be used, for example, with monitoring unit **812** (see, e.g., FIG. **9**). Disc **1900** is similar to disc **816** (FIG. **9**) except that it includes a cleaning element **1904** designed, located, and configured to clean optical reader ports **908(1)** and **908(2)** (FIG. **9**) of monitoring unit **812**. As will be appreciated, optical reader ports **908(1)** and **908(2)** are susceptible to fouling, for example, from bubbles and/or buildup of matter from water **804** (FIG. **8**), such as small particles, and/or algae, etc. When disc **1900** is mounted to monitoring unit **812** (FIG. **9**), as the monitoring unit turns the disc during operations, cleaning element **1904** intermittently sweeps over optical port **908(1)** and **908(2)** and thereby cleans the corresponding surfaces, for example, output surface **1636** of spot lensing **1608** and input end **1652** of light pipe **1612** of combined I/LC **1600** of FIG. **16**.

Referring again to FIG. **19**, although cleaning element **1904** can be provided at any suitable location, in this example it is provided in place of one of the chemical indicator locations, of which there are eleven such locations **1908(1)** to **1908(11)** on this particular disc. Cleaning element **1904** resides in a recess **1912** formed within holder **1916** of disc **1900**. As better seen in FIG. **20**, in the embodiment shown cleaning element **1904** comprises a base **2000** and a plurality of bristles **2004** fixedly secured to the base. Cleaning element **1904** is biased into a position in which bristles **2004** are substantially perpendicular to the general plane of chemical indicator disc **1900**. However, the biasing has a spring-like action that allows cleaning element **1904** to pivot in either direction D1 or D2 when the outstanding tips **2008** of bristles **2004** contact a structure, such as combined I/LC **1600** of FIG. **16** when positioned in one of optical reader ports **908(1)** and **908(2)**, while disc **1900** is being rotated.

In the embodiment shown, this biasing action is provided by magnetic attraction, in this example a pair of magnets **2012** and **2016**, one located in base **2000** of cleaning element **1904** and the other located on holder **1916**. It is noted that while a pair of magnets **2012** and **2016** is illustrated, the magnetic attraction can be implemented in another way, such as between a single magnet and a ferromagnetic material or between more than one magnet in/on base **2000** and in/on holder **1916**. As those skilled in the art will understand, the mutual attraction of magnets **2012** and **2016** to one another along with the specially curved rocking surface **2020** of base **2000**, allows cleaning element **1904** to effectively rock on rocking surface **2020** in response to forces encountered at bristle tips **2008**. The strengths of magnets **2012** and **2016** and the curvature of rocking surface **2020** can be varied to vary the pivoting (rocking) response and cleaning effectiveness of cleaning element **1904**. Magnets **2012** and **2016** can ideally be diamagnetic types which are attracted on the sides vs. the ends of their rod shape. This diamagnetic attraction and magnetic pole alignment also provides for some of the return spring-like effect when deflected in either direction D1 or D2. In one example, base **2000** can be made of a plastic portion **2024** that is molded around magnet **2016**. Magnet **2012** can be inserted into a suitable recess **2028** formed in the "back" side of holder **1916**. Such insertion can involve, for example, an adhesive, a press fit or an interference fit, and/or the insertion can be

followed by application of a closure **2032** to keep magnet **2012** in its place when magnet **2016** (i.e., cleaning element **1904**) is not present.

While cleaning element **1904** is shown as a brush-based element, it can be of another type. For example, bristles **2004** can be replaced by another type of cleaning means, such as a sponge, squeegee, cloth, rubber-fingered, etc., cleaning mean. In addition, it is noted that while the biasing means is provided by magnetic attraction, it can be provided in another manner. For example, cleaning element **1904** can be modified so that magnet **2012** is a central shaft that is rotatable mounted to holder **1916**, and the biasing can be provided using a suitable spring means, such as one or more torsional springs, one or more spiral springs, one or more coil springs, one or more resilient bumpers, among others, and any combination thereof. In yet another embodiment, base **2000** can be fixed to holder **1916** and bristles **2004** can be made sufficiently flexible and resilient so that they flex a predetermined amount when they swipe over any protruding optical element, such as combined I/LC **1332** (FIG. **13**), at either of optical reader ports **908(1)** and **908(2)** (FIG. **9**).

Depending on the configuration of monitoring unit **812** (FIG. **8**), it can drive the chemical indicator disc that is engaged with it, such as disc **816**, continuously at relatively fast speeds. As mentioned above, this can be desirable for causing the water between the disc and monitoring unit **812** to be exchanged relatively rapidly. This relatively fast rotation can be leveraged for cleaning one or more optical reader ports, such as either of ports **908(1)** and **908(2)** of FIG. **9**. In the embodiment shown in FIG. **21**, a chemical indicator disc **2100** can be fitted with a cleaning element **2104** that is activated by spinning disc **2100** relatively rapidly. While FIG. **21** illustrates cleaning element **2104** as having a pair of brushes **2108(1)** and **2108(2)**, it is noted that it can have more or fewer brushes. In one alternative, the cleaning element can have a single brush. In such case, the single brush can be deployed to a cleaning position only by move disc **2100** in one direction, but not the other. It is also noted that each brush **2108(1)** and **21(2)** can be replaced with a different type of cleaning device, such as a sponge, squeegee, etc. Cleaning element **2104** is pivotably mounted within a recess **2112** formed in disc **2100** and has a neutral position **2116** during normal monitoring operations when the disc is moved relatively slowly and/or in relatively small increments. The pivotability of cleaning element **2104** can be provided in any of a number of manners, such as using a magnetic attachment (such as the magnetic attachment illustrated above in FIGS. **19** and **20** in connection with cleaning element **1904**), an axle arrangement, and an end-pin/rotational bearing arrangement, among others. As can be seen, when cleaning element **2104** is in its neutral position **2116**, brushes **2108(1)** and **2108(2)** do not contact reader optic **2120**. However, during rapid rotation of disc **2100** to the left as illustrated at arrow **2124**, the resistance of the water in the space **2128** between disc **2100** and reader optic **2120** on brush **2108(1)** causes brush **2108(1)** to deploy, by pivoting about axis **2132**, into an outstanding cleaning position **2136** in which it contacts the optical port, thereby cleaning the port. Cleaning element **2104** shown is a bi-directionally operative cleaning element, meaning that when disc **2100** is rotated in the direction opposite direction **2124**, then the cleaning element would pivot in the opposite direction, meaning that brush **2108(2)** would be outstanding instead of brush **2108(1)** in its cleaning position **2136**. In the example shown, cleaning element **2104** is biased into its neutral position **2116** using any suitable biasing means, such as a spring element **2140**, which is configured to allow the

cleaning element to pivot in both directions relative to its neutral position, one of which, i.e., cleaning position **2136**, is illustrated in FIG. **21**. Alternatively, diamagnetic magnet pairs such as in FIG. **20** can also return cleaning element **2104** back to neutral position.

FIG. **22** illustrates a water quality monitoring unit/chemical indicator disc system **2200** that includes a monitoring unit **2202** and a chemical indicator disc **2204** engaged with the monitoring unit. Monitoring unit **2202** and disc **2204** can be embodied, respectively, as monitoring unit **812** and chemical indicator disc **816** and, therefore, have any of the functionality of those components that is described above. For brevity, those functionalities will not be re-described relative to system **2200** and only some are mentioned in this description of FIG. **22**. However, the reader should understand that any unmentioned functionalities and/or any undescribed details are indeed present in system **2200** and reference can be made to the foregoing description should further information be needed or desired. Disc **2204** is rotatably engaged with monitoring unit **2202** via an electrically conductive receiver **2206** so that electrical charge can be conveyed to the disc for the reasons noted above.

Monitoring unit **2202** includes four optical readers **2208(1)** to **2208(4)** for reading the chemical indicators (not shown) present on chemical indicator disc **2204**. In this example: optical reader **2208(1)** is designed and configured for illuminating and detecting absorbance at 590 nm wavelength; optical reader **2208(2)** is designed and configured for illuminating and detecting absorbance at 720 nm wavelength; optical reader **2208(3)** is designed and configured for exciting and detecting fluorescence; and optical reader **2208(4)** is also designed and configured for exciting and detecting fluorescence. Each of optical readers **2208(1)** to **2208(4)** includes an optical assembly **2212(1)** to **2212(4)** that includes one or more suitable light sources (not shown), one or more suitable light sensors (not shown), and a combined I/LC **2214(1)** to **2214(4)**. Optical reader **2208(1)** has illumination and detection circuitry **2216(1)** designed and configured to send driving signals to, and receive detected signals from, optical assembly **2212(1)**; optical reader **2208(2)** has illumination and detection circuitry **2216(2)** designed and configured to send driving signals to, and receive detected signals from, optical assembly **2212(2)**; optical reader **2208(3)** has excitation and detection circuitry **2216(3)** designed and configured to send driving signals to, and receive detected signals from, optical assembly **2212(3)**; and optical reader **2208(4)** has excitation and detection circuitry **2216(4)** designed and configured to send driving signals to, and receive detected signals from, optical assembly **2212(4)**. In this embodiment, each of illumination/excitation and detection circuitries **2216(1)** to **2216(4)** is analog circuitry that is in operative communication with analog signal conditioning circuitry **2218**, which in turn is controlled by a processing system **2220** that controls virtually all operations of system **2200**, including data processing.

Processing system **2220** may include one or more microprocessors, microcontrollers, central processing units, etc., or any logical combination thereof. There are fundamentally no limitations on how processing system **2220** can be embodied, including centralized processing architectures and distributed processing arrangements. Processing system **2220** includes one or more memories, collectively represented by memory **2222**, used to store (transitorily and/or non-transitorily, depending on type) machine-executable instructions **2224**, data **2226**, and other digital information that allows processing system to control the operation of system **2200**. Examples of memories that can be aboard

monitoring unit **2202** include, but are not limited to, hardware storage memory (removable or non-removable), random-access memory, and cache memory, among others. In addition, memory can be of any suitable type, including transistor based, magnetic, optical, etc. Fundamentally, there is no limit on the nature and type of memory that can be used in processing system **R20**.

In addition to optical readers **2208(1)** to **2208(4)**, monitoring unit **2202** includes other sensors/detectors. These include: 1) a temperature sensor **2228**; 2) a conductivity sensor **2230**; 3) a sound detector **2232**; and 4) a water level detector **2234**, each of which in this embodiment is in operative communication with analog signal conditioning circuitry **2218**. It is noted that in other embodiments, some or all of analog signal conditioning circuitry **2218** may not be needed if the outputs (and/or inputs) of the various sensors, detectors, and readers are digital. Temperature sensor **2228** is provided for measuring the temperature of the water (such as water **804** in FIG. **8**) in which monitoring unit **2104** is fully or partially submerged so that monitoring unit **2202** can estimate the temperature of the chemical indicators on the chemical indicator apparatus that is engaged with the monitoring unit. Temperature compensation can be a very important aspect for ensuring monitoring unit **2202** is outputting meaningful information based on readings taken by optical readers **2208(1)** to **2208(4)**. For example, some chemical indicators are relatively sensitive to temperature, whereas others are not. In addition to monitoring unit **2202** being programmed (see, e.g., software (machine-executable instructions **2224**)) to adjust reading data based on the temperature of the chemical indicators, the monitoring unit can also be programmed to make adjustments to compensate for the varying performance of light sources due to temperature changes and/or to compensate for detector performance variation due to temperature changes. In this connection, though not shown, the circuit board(s) on which the light sources and/or detectors are mounted can include one or more temperature sensors for measuring the temperature of the light sources and detectors. Relative to chemical indicator temperature, it is noted that a chemical indicator apparatus of the present disclosure, such as chemical indicator disc **816** of FIGS. **8** and **9**, could be provided with a color changing temperature indicator that changes color depending on its temperature. Correspondingly, for example, one of optical readers **2208(1)** to **2208(4)** could be configured to determine the color of the temperature indicator. Monitoring unit **2202** could then use the determined color to determine the temperature of disc **816** and use that temperature to make the corrections noted above. A benefit to using a color changing temperature indicator on the chemical indicator apparatus is that the temperature is read from the disc itself. In addition, the accuracy of water contacting temperature probes can be affected by the flow of the water.

Referring again to FIG. **22**, conductivity sensor **2230** may consist of a pair of spaced electrodes **2236** that contact the water in which disc **2204** is submerged to allow the monitoring unit to measure the conductivity of that water. As those skilled in the art will understand, a conductivity measurement made using conductivity sensor **2230** can be used to infer the presence of various constituents within the water. Sound detector **2232** can be provided to detect the operating state (on, off, speed, etc.) of any water pumps, wave generators, and/or other device(s) that produce one or more detectable sounds/vibrations when operating. Knowing the operating state(s) of such one or more devices allows, for example, monitoring unit **2202** to use that

information to control its own operation, such as the operation of any one or more of optical reader(s) **2208(1)** to **2208(4)**, to allow a user to remotely listen to the operation of her/his aquarium equipment, and/or to issue an alert that one or more of the monitored devices is not functioning correctly, among other things. Water level detector **2234** can be provided for measuring the level of the water in container (not shown) in which monitoring unit **2202** is deployed, such as an aquarium container or sump. As those skilled in the art will appreciate, water level data can be used for controlling monitoring unit **2202** and/or any remote devices, such as a make-up water valve, and/or for determining whether or not to issue any alerts as to too high or too low of a water level.

Monitoring unit **2202** includes a voltage controller **2238** in electrical communication with analog signal conditioning circuitry **2218** for providing a voltage to conductive receiver **2206**, which in turn provides the voltage to disc **2204** to provide one or more of the chemical indicators (not shown) onboard the disc with an enhanced range. Monitoring unit **2202** also includes a stepper motor **2240** that drives disc **2204** via magnetic coupling as described above in response to control input from processing system **2220**. In this example, a magnet holder **2242**, which supports magnets **2244(1)** and **2244(2)**, is driven by motor **2240**, and the magnetic interaction of magnets **2244(1)** and **2244(2)** with corresponding respective oppositely polarized magnets **2246(1)** and **2246(2)** on disc **2204** drives the corresponding rotation of the disc.

Monitoring unit **2202** includes first and second radios **2248** and **2250**, respectively, controlled by processing system **2220**. In the embodiment shown, first radio **2248** is provided for communicating with one or more local area network devices, for example, wireless TCP/IP router, radio-enabled smartphone, tablet computer, laptop computer, desktop computer, etc. First radio **2248** may be the primary communications device, for example, for receiving operating parameters from an off-monitor software application and for communicating measurement data, monitor status information, and other information, such as audio from sound detector **2232**, to the external device(s), and/or to an off-monitor software application for receiving such information. In one embodiment, first radio **2248** is designed and configured to operate under any one or more of the IEEE 802.11 standards, but the radio can be designed and configured to work under any other suitable standard(s).

In this example, second radio **2250** is included to provide a small area network or piconet to allow monitoring unit **2202** to communicate with proximate external devices that are part of the overall aquatic-environment environmental control scheme. Examples of such external devices include, but are not limited to, one or more: lighting devices **2252** for providing light to the aquatic environment; chemical dosers **2254** for dispensing one or more chemicals to the aquatic environment; feeding devices **2256** for dispensing food to the aquatic environment; water pumps **2258** for circulating water within the aquatic environment; wave generators **2260** for generating waves within the aquatic environment; and power strips into which these and other devices are plugged. In one example, second radio **2250** is designed and configured to utilize BLUETOOTH® standards. However, second radio **2250** can be designed and configured to work under any other suitable standard(s). It should be noted that while two radios are shown, that a single radio which supports multiple modes and standards can also be used to provide both the proximate local communications and the network connectivity.

Monitoring unit **2202** includes power supply **2262** that provides conditioned power to other components and circuits onboard the monitoring unit. Power supply **2262** can include voltage regulation circuitry that provides a high-precision electrical reference, which can be very important for taking readings and/or driving the light sources. Other components of monitoring unit **2202** may include a suitable timing source, such as a crystal oscillator, for ensuring that timing throughout the system is precise, such as for controlling integration times of light detectors. In one embodiment, wherein monitoring unit **2202** is designed and configured to be located within a water container (represented by wall **2264** in FIG. **22**), for example, aquarium sump, aquarium tank, filter tank, skimmer box, etc., that is part of the aquatic environment in which monitoring unit **2202** is deployed, power supply **2262** receives power through the wall of the container via an inductively coupled transformer system **2266**. In this example, inductively coupled transformer system **2266** includes a first transformer component **2268** in electrical communication with power supply **2262** and a second transformer component **2270** in electrical communication with an external power source, such as a domestic power outlet (not shown) via a suitable power cord **2272**. During use, one or more induction coils (not shown) within second transformer component **2270** induce electrical current to flow within one or more induction coils with first transformer component **2268** via magnetic coupling between the induction coils in the two components. In turn, first transformer component **2268** provides the resulting electrical energy to power supply **2262** to power monitoring unit **2202**. Advantages of this magnetic coupling include the ability to avoid running a power cord into the water container and needing to create a liquid seal at any opening in monitoring unit **2202** needed to run such power cord into the unit. As those skilled in the art will understand, wall **2264** of the water container can be made of any non-magnetic material, such a plastic, glass, wood, non-magnetic composite, etc., and any combination thereof. Alternatively, or in addition, monitoring unit **2202** can include a power port, such as a low voltage DC power port **2274**, that alternatively provides power to power supply **2262**.

Monitoring unit **2202** may also include an accelerometer **2276**, such as a 3-axis accelerometer. As discussed above relative to monitoring unit **812** of FIGS. **8** and **9**, accelerometer **2276** can be used in a scenario in which monitoring unit **2202** can become disengaged from any structure it is engaged with to determine when that disengagement has occurred. If an abnormal acceleration is detected using accelerometer **2276**, processing system **2220** can be programmed to issue a suitable alert to notify a user of the (possible) disengagement.

In some cases, when a monitoring unit made in accordance with the present disclosure is sealed for watertightness, pressure changes during shipping, such as shipping by air, can affect the precision alignments and/or positional tolerance of various critical components of the unit, such as components of the optical readers, such as light sources, optics, light detectors, etc. Large pressure differentials experienced during shipping can cause permanent deflections in various components, such as housing components that can affect reading accuracy of the unit. To combat this, a watertight monitoring unit, such as monitoring unit **2202** of FIG. **22**, can be provided with a pressure equalization system that allows the pressure inside the unit to adjust to the pressure on the outside of the unit. In one example, a pressure equalization system includes a water-impermeable/air-permeable membrane **2278** that allows air to pass

through for air-pressure equalization during shipping and can be left in place without any end-user interaction to keep monitoring unit **2202** watertight for use.

FIG. **23** illustrates a monitoring unit **2300** that is similar to monitoring unit **2202** of FIG. **22** in that it is designed to be at least partially submerged in the water that it is designed to monitor. However, in monitoring unit **2300** not only is power provided to the monitoring unit via inductive coupling of first and second transformer components **2304** and **2308**, respectively, but data and other information is transmitted from and to monitoring unit via inductive coupling of first and second inductive digital couplers **2312** and **2316**, respectively. First inductive digital coupler **2312** is operatively coupled to a suitable processing system **2320** that can perform largely the same functions as processing system **2220** of FIG. **22**. Second inductive digital coupler **2316** can likewise communicate with a processing system **2324** that, in turn, can communicate with one or more communications devices **2328** and **2332**, each of which can be, for example, a wired digital data port (such as a universal serial bus port, a FIREWIRE® port, etc.) or a radio (such as a BLUETOOTH® radio, a WIFI™ radio, etc.), among other things.

In alternative embodiments, processing system **2324** can be eliminated, with data and information from and to second inductive coupler **2316** being provided directly to the one or more communications devices **2328** and **2332** or an intermediary device(s) (not shown) other than processing system **2324**. In various alternative embodiments, first and second inductive digital couplers **2312** and **2316** can be integrated into inductive transformer components **2304** and **2308** by suitably superimposing data signals on the power signals and using suitable encoders and decoders for the embedded signals as known in the art. In addition, in various other alternative embodiments, first and second inductive digital couplers **2312** and **2316** can be replaced by other suitable wireless data communications devices that can communicate data across wall **2336**, such as very-near-range radio devices and optical devices, such as infrared transmitters, receivers, and/or transceivers, among other wireless data communications devices.

Depending on the intended deployment of monitoring unit **2300**, locating communications device(s), here devices **2328** and **2332**, outside of the water container (represented in FIG. **23** by wall **2336**), can avoid transmission interferences, allow monitoring unit **2300** to be fully submerged at any depth, and allow the data communications to be wired without the need to run any wires into the container, among other advantages. It is noted that while processing system **2320** is shown as being inside the water container, it could alternatively be on the outside, effectively taking the place of processing system **2324**. In those embodiments, the portion of monitoring “unit” on the inside of the water container would be largely only the optical reader **2340(1)** to **2340(4)** and various sensors/detectors **2344(1)** to **2344(4)** and their corresponding respective driving circuitries. Most or all processing and external communications would be performed outside the water container.

FIG. **24** illustrates an exemplary aquarium setup **2400** that includes an aquarium monitoring system **2404** and a doser **2408** for continually monitoring the quality of water **2412** and dispensing one or more appropriate additives to the water to keep the water quality within certain desired tolerances. Monitoring system **2404** can be, for example, a chemical-indicator-disc-based monitoring system that is the same as or similar to monitoring system **800** of FIG. **8**. Doser **2408** can be any suitable doser that can be remotely or locally controlled to provide the dispensing of one or

more chemicals and/or other additives, here two additives **2416(1)** and **2416(2)**, needed to keep the water **2412** within the aquatic environment, here an aquarium **2420**, within certain desired quality tolerances. In this example, doser **2408** includes a dispensing mechanism **2424(1)** and **2424(2)** for each of the two additives **2416(1)** and **2416(2)** to controllably dispense the corresponding additive. In this example, each dispensing mechanism **2424(1)** and **2424(2)** is a peristaltic pump that can be controlled to dispense highly precise amounts of liquid. In other embodiments, the doser can dispense more or fewer than two additives and can include any suitable type of dispensing mechanism(s) in addition to, or in lieu of, the peristaltic pumps illustrated.

In aquarium setup **2400**, monitoring system **2404** can communicate automated dispensing instructions **2428** to doser **2408** via a piconet radio system **2432** in which the monitoring system and doser are provided with piconet radios (not shown) wherein there is at least one-way communication from the monitoring system to the doser. Alternatively, wired or other wireless communications may be used. To provide this functionality, monitoring system **2404** can be provided with a dosing calculator **2436** in which automated dispensing instructions **2428** are determined based on water quality measurements made by the monitoring system, for example, using any of the measuring and monitoring techniques described above. Dosing calculator **2436** can, for example, be located onboard a monitoring unit **2440** of monitoring system **2404**, located off-board the monitoring unit, such as in a cloud-computing platform **2444** and/or on a computing device **2448** (such as a smartphone, tablet computer, laptop computer, desktop computer, etc.), or any combination of distributed functionality.

When monitoring system **2404** is configured to communicate with a local, wide, or global area network (such as, e.g., the Internet), it can be provided with a suitable communications system **2452** that allows it to communicate with the appropriate network or networks. In the present example, communications network **2452** includes a wireless connection **2456** between monitoring unit **2440** and a wireless router **2460**, which itself is operatively connected to cloud-computing platform **2444**. If some or all of dosing calculator **2436** is located remotely, such as on cloud-computing platform **2444** and/or a computing device **2448**, automated dispensing instructions **2428** can be communicated to monitoring unit **2440** via communications network **2452**, and the monitoring unit can relay the instructions to doser **2408**. Alternatively, for example, if doser **2408** is outfitted so that it can communicate with wireless router **2460**, the automated dosing instructions **2428** can be provided directly to the doser to avoid such relaying.

Alternatively, or in addition, to automated dosing, monitoring system **2400** can be configured to provide assisted dosing, i.e., configured to provide a person who maintains an aquarium (hereinafter “user” **2464**) with assisted dosing instructions **2468**. Dosing calculator **2436** can be configured to generate assisted dosing instructions **2468** along with, or in lieu of automated dosing instructions **2428**. Monitoring system **2404** can provide assisted dosing instructions **2468** to any suitable computing device **2448** available to user **2464** and/or to a display **2472** on monitoring unit **2440** and/or a display on doser **2408**. As those skilled in the art will readily appreciate, assisted dosing instructions **2468** can be in any suitable format, such as a tabular form that simply lists the additive and the amount to be added, a demand form, such as “Add 10 ml of pH increaser to sump while pump is running”, or both, or any other type of instructions for the user to add the proper amount.

With either of assisted dosing and automated dosing, monitoring system **2404** can be configured to monitor water **2412** more frequently during dosing, such as to ensure that dosing is proceeding correctly. For example, with automated dosing, monitoring unit **2440** can switch to an “enhanced monitoring” mode in which the monitoring unit monitors continually for a predetermined period at short intervals once it has sent automated dosing instructions **2428** to doser **2408**. The period that monitoring unit **2440** performs enhanced monitoring can be determined as a function of the type of additive(s) being added and/or the amount of the additive(s) being added. The enhanced monitoring period can extend for a predetermined amount of time beyond dispensing as may be required for the water quality parameters of water **2412** to rebalance, settle, etc. following dosing. In addition, the particular chemical indicator(s) and/or other sensing (e.g., temperature sensing, conductivity sensing, etc.) that is performed during enhanced monitoring can be tailored to the particular additive(s) being added. For example, if only a particular additive is being added for a particular dosing, only one or more chemical indicators and/or other specific sensing needed to be done during the enhanced monitoring.

Enhanced monitoring during dosing can be performed completely in lieu of normal routine monitoring, i.e., routine monitoring is not performed, or the enhanced monitoring can be performed in addition to normal routine monitoring. If enhanced monitoring detects an abnormality, such as the wrong additive being dispensed, too much additive being dispensed, the additive being dispensed too quickly, or the additive not causing any change (perhaps indicating that the corresponding additive reservoir is empty or a hose is plugged, etc.), among others, monitoring system **2404** can, for example, take any necessary corrective measure (including dispensing an “antidote” additive, stopping dispensing, running diagnostics, etc.) and/or issue one or more suitable alerts to the user, among other things. In the case of assisted dosing, the user can signal monitoring system **2404** that it has begun dispensing using one or more suitable controls. For example, if assisted dosing instructions **2468** are being displayed on a smartphone (e.g., computing device **2448**) and the instruction are, for example, being displayed using a software application, or “app,” **2472** for interfacing with monitoring system **2404**, then the app may display on a GUI **2476** on the smartphone a soft button **2480** or other control labeled “Dispensing Started”, or the like. By user **2464** activating button **2480**, monitoring system **2404** is notified to start operating in the enhanced monitoring mode. Depending on the type of additive being used and its effect(s) on water **2412**, additional user interaction can be provided to GUI **2476**. For example, GUI **2476** can be provided with a soft button **2480** or other control that user **2464** is instructed to actuate each time she/he has dispensed a certain amount of the additive into water **2412**.

In order for dosing calculator **2436** to properly determine dosing instructions, for example, either automated dosing instructions **2428** or assisted dosing instructions **2468**, or both, it may need to know one or more pieces of information about aquarium setup **2400** and about the additives being added. Examples of information that dosing calculator **2436** may need to know about aquarium setup **2400** includes the volume of water **2412** in the setup, the type of the water (e.g., fresh, brackish, salt, etc.), and the one or more species of aquatic life (e.g., fish, coral, plants, etc.) that aquarium **2420** is supporting, the number of each species, the approximate mass of any coral, other environmental information, and any combination thereof. Examples of information that

dosing calculator **2436** may need to know about each additive include, but are not limited to, the form (e.g., powder, liquid, gel, etc.), a concentration of the additive, the chemistry of the additive, other additive data, and any combination thereof. In lieu of, or in supplement or complement to, providing information of this type, user **2464** may input into monitoring system **2404** brand and product identification information in any one or more of a number of ways, such as by keying in the information, making a selection from a list of choices, and scanning a product code (e.g., bar code, QR code etc.), among others. If a mechanical doser, such as doser **2408**, is used either manually or especially automatically, dosing calculator **2436** may also need to know information about the doser, such as its dosing instruction set and other dosing parameters. Depending on the implementation of aquarium setup **2400**, doser information can be provided to dosing calculator **2436** in any of a number of ways, including keyed entry, product code scanning, make and model selection from lists, data transfer via a network, etc. Those skilled in the art will understand the information that dosing calculator **2436** needs to provide proper dosing instructions, such as automated dosing instructions **2428** and assisted dosing instructions **2468**.

Robustness Features

With the foregoing examples and operating principles in mind, following are a number of features that can be provided as desired to a water quality monitoring/measuring system/units, including any of the systems and units described in this disclosure and that would be evident in view of such description. These features can be broadly termed "robustness features" in that they enhance the robustness of the systems/monitors to which they are added. These robustness features include features for reducing the effect of bad measurements due to: 1) contamination of a chemical indicator; 2) aging of a chemical indicator; and 3) when a magnetically coupled chemical indicator apparatus is used, friction between the chemical indicator apparatus and the receiver on which the indicator is mounted. The robustness features also include protecting against overdosing and protecting against dosing too quickly (e.g., to protect certain species of life supported by a particular aquatic environment being monitored, to prevent precipitation or other chemical reaction, etc.). Each of these robustness features is described in this section. It is noted that each of these features need not necessarily be implemented in conjunction with any particular system or component of the present disclosure, but rather can be implemented separately so as to include only the necessary supporting features and elements.

Multi-Reading Fault Detection/Handling

Detection and/or handling of faults caused, for example, by one or more bad regions on a chemical indicator (such as a region where an indicator dye is lacking, damaged, or occluded by contamination) can be handled by acquiring multiple readings from a single chemical indicator. An example of a multi-reading fault detection/handling scheme is described in this section in connection with FIGS. **25** and **26**.

FIG. **25** illustrates a chemical indicator **2500** from which multiple optical readings are taken. Each location that is illuminated and from which an optical reading is taken is indicated by a corresponding circle **2504**. It is noted that chemical indicator **2500** can be any one of chemical indicators/chemical indicator patches described in examples above. In this connection, it is noted that while chemical indicator **2500** is depicted in FIG. **25** as residing on a discoidal chemical indicator apparatus **2508** such that the chemical indicator is arcuate, it is noted that the same or

similar multi-reading scheme can be implemented on a chemical indicator of virtually any suitably sized and shaped area. As more fully described below, each circle **2504** approximates a spot of illumination light that is used to illuminate the corresponding region of chemical indicator **2500**. Each illumination can be, for example, for fluorescence readings, absorbance readings, reflectance readings, and/or for reference purposes, for example, as described below in connection with reference illumination. It is noted that the number and locations of the spots of illumination in this example are merely illustrative and should not be considered limiting. Indeed, those skilled in the art will readily appreciate that there are many ways in which multi-reading fault detection can be implemented with differing patterns of illumination and/or differing locations of illumination, among other variables that can be changed from the illustrative example of FIG. **25**.

As used in the following example, illumination for measurements (e.g., fluorescence readings and absorbance readings) are each referred to as "measurement illumination" as these illuminations are for taking measurements based on the chemical activity of the chemical dye(s) within chemical indicator **2500** in response to one or more constituent(s) of the water that the chemical indicator is designed for. On the other hand, illumination for determining the presence of contamination and/or other optical interferents (e.g., particulates in water) and conditions (e.g., improper distance between a reader and a chemical indicator being read) that affect indicator measurements (e.g., using reflectance readings) is referred to as "reference illumination," as this illumination is used as a reference to detect the presence of, for example, 1) any one or more contaminants on and/or in chemical indicator **2500** that may interfere with the fluorescence and/or absorbance of the chemical indicator, 2) a matter in the water located between a measurement reader and the chemical indicator that may affect the measurements being taken by the reader, and 3) any deviation of distance between a reader and the chemical indicator that may affect the measurements being taken by the reader, and any combination thereof. Examples of contaminants include, but are not limited to, surface contaminants such as algae and particulates, as well as physical defects/damage to chemical indicator **2500** itself, such as scratches and gouges. It has been found that many types of these and other contaminants tend to interfere with the reflectivity of a chemical indicator. Consequently, reflectivity readings and data taken from across a chemical indicator, such as chemical indicator **2500** can reveal where contamination may be present. Knowing this, and the fact that fluorescence and/or absorbance measurements taken at locations where contaminants are present, can allow a monitoring system/unit to determine whether or not a particular measurement reading is a trusted reading (i.e., one taken where contamination is likely not present as determined from the reference illumination and reading) or not a trusted reading (i.e., one taken where contamination is likely present). The monitoring system/unit can then be programmed to, for example, discard or treat with a lower weighting each non-trusted reading. In addition, taking multiple ones of each type of measurement reading on a single chemical indicator provides the ability to use statistics, such as averaging, to gain confidence in the measurements. Particular sets of these readings having particular usefulness are described below.

In addition to using averaging and/or trusted reading techniques on the measurement illumination spots, similar techniques can be used for the reference illumination spots. For example, an algorithm can be used to sort readings from

each chemical indicator and pick the most common values. When the reading being taken from a reference illumination spot is based on reflectivity, contamination on the chemical indicator could cause more or less reflection. For example, calcium carbonate might start to leave a white film on a chemical indicator, which would cause the reflected light to be more intense. Regardless of whether the contamination causes a brighter or dimmer reflection, in one example only the most closely matched N readings are used for averaging and determining the measurement, and the remaining readings are discarded as being unreliable.

In one example of a multi-reading scheme, four light sources (not shown) are used to illuminate four corresponding spots **2512(1)** to **2512(4)**, with spots **2512(1)** and **2512(2)** consisting of one or more wavelengths that are not involved with fluorescence excitation and absorbance relative to chemical indicator **2500**. Illumination spots **2512(1)** and **2512(2)** are for reference illumination. Spots **2512(3)** and **2512(4)**, on the other hand, are for measurement illumination. Both spots **2512(3)** and **2512(4)** can be of the same or differing wavelengths (or wavelength bands) depending on the makeup of the relevant dye(s) within chemical indicator **2500**. In one example, both spots **2512(3)** and **2512(4)** are for exciting the same fluorescence and contain the same excitation wavelength(s). This effectively allows the number of measurement readings on chemical indicator **2500** to be doubled. In another example, one of spots **2512(3)** and **2512(4)** is for an absorbance measurement and the other spot is for a fluorescence measurement. In a further example, one of spots **2512(3)** and **2512(4)** is for a first fluorescence measurement at one excitation wavelength and the other spot is for a second fluorescence measurement at a second excitation wavelength. In a still further example, one of spots **2512(3)** and **2512(4)** is for an absorbance measurement at a first absorbance wavelength and the other spot is for an absorbance measurement at a second absorbance wavelength. Those skilled in the art will readily appreciate the wide variety of scenarios that are possible depending on the makeup of a particular chemical indicator and the optical phenomenon(a) being measured. Of course, more or fewer spots of illumination can be used as desired to suit a particular use. In an example, spots **2512(1)** to **2512(4)** are typically illuminated at differing times so that the light from one does not interfere with readings for another. FIG. **26** below illustrates one example of reader optics **2600** that can be used to implement the four spot illumination scenario illustrated in FIG. **25**.

In one exemplary implementation and with continuing reference to FIG. **25**, once spots **2512(1)** to **2512(4)** have been illuminated and corresponding readings have been acquired, the same pattern of spots are essentially replicated at corresponding respective spots **2516(1)** to **2516(4)**, such that reference illumination spots **2516(1)** and **2516(2)** substantially or entirely overlap, respectively, the regions of chemical indicator **2500** previously illuminated by measurement illumination spots **2512(3)** and **2512(4)**. With this overlap, reference illumination spots **2516(1)** and **2516(2)** are used to determine whether any contamination is, or is likely to be, present where measurements were previously taken using measurement illumination spots **2512(3)** and **2512(4)**, respectively. If, for example, the results of the readings from reference illumination spots **2516(1)** and **2516(2)** indicate that one, the other, or both of the corresponding regions on chemical indicator **2500** are contaminated, then the corresponding monitoring system/unit can take a corrective action such as, for example, discard or assign a lesser weight to the reading(s) at the contaminated

spot(s). Illumination spots **2516(3)** and **2516(4)** are new measurement illumination spots for taking measurement readings of chemical indicator **2500**. As will be readily understood, as the pattern of the four illumination spots is stepped across chemical indicator **2500** (in this example seven times) to create substantial overlap or virtually exact coincidence of each reference illumination spot with a corresponding measurement illumination spot, each measurement spot can be tested for contamination. In the embodiment shown in FIG. **25**, if discoidal chemical indicator apparatus **2508** is mounted to monitoring unit having a stepper motor, such as monitoring unit **2202** of FIG. **22**, the stepping of the four-spot pattern can be performed by controlling the stepper motor to drive the chemical indicator apparatus by one or more steps to achieve the desired alignment of the measurement and reference illumination spots of the pattern. In other embodiments, for example embodiments wherein the chemical indicator apparatus is linearly movable with respect to an optical system that creates the multi-spot pattern, the corresponding monitoring unit can move the chemical indicator in a linear stepwise fashion to create the desired alignment of the measurement and reference illumination spots of the pattern. In still other embodiments in which the chemical indicator apparatus is fixed and the optical system(s) that generate(s) the illumination pattern is/are movable, then such optical system(s) can be moved in a stepwise fashion accordingly.

It is noted that in some embodiments it is desirable to keep the illumination spots in the pattern of spots at issue, such as measurement and reference illumination spots **2512(1)** to **2512(4)** in the four-spot pattern illustrated, from overlapping one another. This not only allows the measurement locations on a given chemical indicator to be discrete and independent, but it also assists in reducing photo-aging of the chemical indicator, especially if it is one that is highly susceptible to photo aging. As those skilled in the art will understand, many fluorescent and absorptive dyes that can be used in a chemical indicator of the present disclosure undergo photo-aging, i.e., they become less responsive with increasing amounts of light exposure. Keeping the individual spots in a given pattern, such as the four-spot pattern of FIG. **25**, from overlapping, may reduce the overall exposure of each region of the indicator that is illuminated by the corresponding illumination spots to only the light that is necessary for measurement and contamination readings of that region.

As can be readily appreciated, a monitoring system/unit can utilize the multi-reading, iterative stepping process illustrated with respect to FIG. **25**, or other similar process, to ensure that the measurement and contamination readings are being taken from the correct chemical indicator. As seen in FIG. **25**, chemical indicator **2500** is located adjacent a second chemical indicator **2520** but is separated therefrom by a space **2524**, which can be, for example, a bare part of the holder **2528** of chemical indicator apparatus **2508**. Since space **2524** will typically have (much) different optical responses than chemical indicators **2500** and **2520** to the measurement and reference illumination light, here spots **2532(1)** to **2532(4)**, than both of the chemical indicators, the measurement and contamination readings taken from space **2524** will typically be discernible from measurement and contamination readings made on the chemical indicators. Analysis of the reading data by a monitoring system/unit can reveal where those typically vastly different readings lie in the data, and these readings can be used to separate readings taken from adjacent chemical indicators.

FIG. 26 illustrates an exemplary reader optics system 2600 that can be used to generate the four-spot illumination pattern illustrated in FIG. 25 and also to obtain readings based on those spots. Referring to FIG. 26, optics system 2600 includes a combined I/LC 2604 that can be the same as or similar to combined I/LC 1600 of FIG. 16 or combined I/LC 1800 of FIG. 18 and therefore can include spot lensing 2608 and a central light collector 2612. Optics system 2600 also includes four light sources, here four lensed LEDs 2616(1) to 2616(4), that provide light to spot lensing 2608, which in turn uses the light to form four corresponding respective illumination spots 2620(1) to 2620(4) on a target 2624, which can be, for example, a chemical indicator, a holder, or other part of a chemical indicator apparatus. Relating illumination spots 2620(1) to 2620(4) to FIG. 25, these spots can correspond, respectively, to illumination spots 2512(1) to 2512(4) and to illumination spots 2516(1) to 2516(4), among other sets of illumination spots not particularly labeled in FIG. 25.

Referring back to FIG. 26, and continuing with the four-spot pattern of FIG. 25, LEDs 2616(1) and 2616(2) can be selected to provide reference illumination, i.e., provide light at one or more wavelengths that is not involved with taking either fluorescence measurements, absorbance measurements, or both. In one embodiment, each of LEDs 2616(1) and 2616(2) emit light at about 720 nm wavelength. Correspondingly, LEDs 2616(3) and 2616(4) can be selected to provide measurement illumination, i.e., illumination that is either fluorescence exciting or absorbed, or both, depending on the particular optical characteristic(s)/response of one or more chemical indicators being measured. As can be readily seen in FIG. 26, illumination spots 2620(1) to 2620(4) substantially do not overlap one another for at least the reasons noted above. In one example, LEDs 2616(1) to 2616(4) are controlled by a suitable controller 2628 that causes them to illuminate in a manner such that only a single one of the LEDs is turned on at a time. This minimizes the amount of stray light that interferes with any given reading. Optics system 2600 further includes a light detector 2632 that detects the light collected by light collector 2612. In this example, a light filter 2636 is provided to filter unwanted wavelengths from the collected light. Those skilled in the art will readily understand that optics system 2600 is but one example of an optics system that can be used to perform a multi-reading, multi-stepping process, such as the process described above with respect to FIG. 25.

Fluorescence Reading Contamination Compensation

In one exemplary aspect, with fluorescence, it is believed that most naturally occurring contamination/interference on the surface of a chemical indicator will reduce fluorescence, not increase it. Using corresponding reference illumination and measurement illumination spots, such as contamination and measurement spots 2516(1) and 2512(1) of FIG. 25, fluorescence emission measurements can be adjusted using the readings from both illumination spots at any reading location. For example, this adjustment can be made using a ratio of a reading of the reference illumination spot to a known calibration set point. To illustrate, if the reading from the reference illumination spot is supposed to always be 10,000 analog-to-digital (A/D) converter counts but a current reading is 9,800, then the ratio of the reading to the calibration set point is 9,800/10,000, or 0.98. The corresponding reading of the fluorescence emission from the same region of the chemical indicator at issue can then be divided by 0.98 to calculate a corrected reading. This method can also/alternatively be used to compensate for errors due to spacing variations between the reader and a

chemical indicator, turbidity, and other factors. In the example utilizing four LEDs 2616(1) to 2616(4) (FIG. 26), since the same detector 2632 is used for all four light sources, this arrangement inherently compensates for the temperature of the detector.

Ambient Light Compensation

Light from sources other than reader can interfere with the reading process. For example, ambient light from outside a monitoring system, such as light from aquarium lighting, room lighting, the sun, etc., can reach the detector, such as detector 2632 of FIG. 26. To compensate for ambient light, the monitoring system/unit can be programmed to take an ambient light reading just before a reading light source is turned on and a reading integration cycle is started. An ambient light reading can be just an integration of light on the detector for a period of time without any of the reader light sources turned on. Once the ambient light is known, it can be converted into A/D counts per μs , which is a correction factor that can be used to subtract the ambient light value from any given detector integration measurement. For example, if an ambient reading is 500 A/D counts for a 10,000 μs integration time, the correction factor is $500/10,000 \mu\text{s}=0.05 \text{ counts}/\mu\text{s}$. Then, if a 2,000 μs long reading is taken with any of LEDs 2616(1) to 2616(4) and the reading is, say, 8,050 A/D counts, then the reading can be corrected by subtracting from that measurement reading $0.05 \text{ counts}/\mu\text{s} \times 2000 \mu\text{s}=100 \text{ counts}$, such that the final reading adjusted for ambient light is $8,050 \text{ counts}-100 \text{ counts}=7,950 \text{ counts}$. This adjusted reading can then be used in any desired manner to produce measurement information.

Chemical Indicator Spacing Compensation

As described above, a combined I/LC of the present disclosure can be designed and configured to enable the corresponding light detector(s) to detect nearly the same amount of light from a target over a relatively wide range of variation in the position of the target relative to the light source(s) and detector. However, in some cases, such as to further enhance the accuracy of readings of such as combined I/LC or wherein such a forgiving arrangement of light source(s) and detector(s) is not available, it is useful to collect target position information and use this information to adjust detector readings accordingly. In one example, in monitoring unit, such as monitoring unit 2202 of FIG. 22 that includes a pair of electrodes (see, e.g., electrodes 2236 of FIG. 22) for measuring the conductivity of the water, those electrodes can be used to determine the spacing of the chemical indicator apparatus (see, e.g., chemical indicator disc 2204 of FIG. 22) is from the electrodes plane of the electrodes. In other embodiments, spacing information may be determined by other procedures. Using this spacing information and other information known about the chemical indicator apparatus and the monitoring unit, the distance between reader optics (see, e.g., optical assemblies 2212(1) to 2212(4)) can be determined. When the electrodes are close to a corresponding reader optical assembly (such as shown in FIG. 9 with electrodes 936 proximate to reader optical port 908(2)), a conductivity measurement can be taken at each chemical indicator from which a reading will be taken using that reader optical assembly for determining the distance between that chemical indicator and the reader optical assembly. With the distance to the target (here, the chemical indicator) being known, the monitoring unit can use that distance to correct the reading of the corresponding light sensor to account for any difference in brightness of the measurement light reaching the target due the actual distance being different from the design difference. Again, such differences can be due, for example, to tolerances in the fit

of the chemical indicator apparatus with a monitoring unit, wobble of the chemical indicator apparatus due to movement of the water in which the apparatus is submerged, etc. Differences between the design distance to the target and the actual distance to the target can cause differences in the amount of light collected by a light detector of a measurement reader. Consequently, deviations in distance can be accounted for using procedures similar to the procedures describe above in the section titled "Fluorescence Reading Contamination Compensation."

The reason that conductivity measurement electrodes, such as electrodes 2236 of FIG. 22, can be used in determining the distance between reader optics and a target for the optics (such as a chemical indicator) is that when the electrodes are located so that they measure the conductivity of the water between a chemical indicator apparatus and a monitoring unit (or other structure to which the chemical indicator apparatus is engaged (such as an aquarium wall 4628 as in FIG. 46), the conductivity measured relates to the amount of water in that space. Since that volume changes with the distance between the chemical indicator apparatus and the electrodes, the conductivity likewise changes with the distance between the chemical indicator and the electrodes. FIG. 27 illustrates a graph 2700 of conductivity versus time for conductivity readings taken by a monitoring unit of the present disclosure, such as monitoring unit 812 (see, e.g., FIG. 9), as the monitoring unit moved chemical indicator disc 1900 of FIG. 19 past electrodes 936. In this example, disc 1900 contains twelve discrete recesses, eleven containing chemical indicators and one (corresponding to region labeled "10" in graph 2700 of FIG. 27) being a cavity for a cleaning element, such as cleaning element 1904 of FIG. 19. In graph 2700, conductivity profile 2704 provides an indication of error in the distance of disc 1900 (FIG. 19) to the surface of monitor unit 812. In the example of graph 2700, the total variation is about 5.1%. As can be readily appreciated, a conductivity measurement could be taken in conjunction with each fluorescence, absorbance, and/or reflectivity measurement by an optical reader (not shown) in communication with optical reader port 908(2) of FIG. 9. A baseline can be determined, for example, by having the monitoring system/unit measure the average conductivity for all chemical indicator positions. The conductivity for each chemical indicator position can then be expressed as a percentage relative to the average of all positions. An advantage of using conductivity measurements for determining target distance relative to optical approaches is that conductivity is less affected by optical contaminants in the water.

Chemical Indicator Age Compensation

As mentioned in the previous section, aging of a chemical indicator can be a design issue that needs to be considered, for example, for reliability of measurements taken over time as the chemical indicator ages from continual illumination for measurements and/or contamination determination and, in some cases, from ambient light, and from time-aging of indicator dyes themselves. As a chemical indicator ages, the intensity of its response to excitation (fluorescence) or its absorbency, or both, diminishes, and the corresponding diminished readings need to be distinguished from lower readings that are due to changes in the water the chemical indicator is being used to measure. For example, if a monitoring system/unit interprets a low reading as indicating that the level of a particular constituent of the water is below a predetermined threshold, then the monitoring system/unit might recommend that a certain additive be added to the water to bring the level of that constituent back up into

tolerance. However, if that low reading was in fact due to aging of the chemical indicator rather than the level of the constituent being low, then the instruction to dose the water with an additive could easily result in the addition of the additive causing the constituent level to be too high. Consequently, it can be seen that tracking and factoring chemical indicator aging into any measurement data and/or dosing instructions generated by a monitoring system/unit can be an important aspect of ensuring dosing accuracy and water quality.

To at least partially account for photo-aging, a measurement/monitoring system/unit of the present disclosure can be configured to track the amount of light to which each region of a chemical indicator is exposed over the life of the chemical indicator. For example, FIG. 28 illustrates a water quality monitoring system 2800 that includes a monitoring unit 2804, a chemical indicator disc 2808 engaged with the monitoring unit, and a shared, for example, cloud-computing-based, software application 2812 that is in at least intermittent communication with the monitoring unit. Chemical indicator disc 2808 includes a plurality of chemical indicators 2816 and a read/writable RFID device 2820. Correspondingly, monitoring unit 2804 includes an RFID reader/writer 2824. When disc 2808 is manufactured, it is provided with a unique ID 2828 and a data structure 2832 that holds various data, including light exposure data 2836 for the various chemical indicators 2816. In one example, exposure data 2836 is expressed in watt-seconds, which can be readily determined by knowing the output of the relevant light source(s) (not shown) and the cumulative amount of time that each light source is on when exposing a particular indicator, and a particular region on that indicator.

When chemical indicator disc 2808 is first used and it is engaged with monitoring unit 2804, monitoring unit 2804 causes RFID reader/writer 2824 to read unique ID 2828, which the monitoring unit can store and/or send to software application 2812 for product registration and tracking. As monitoring unit 2804 continually takes measurement and/or contamination detection readings from chemical indicator disc 2808 during use, at certain times, for example, regular intervals, continually, at certain clock times, it can cause RFID reader/writer 2824 to write pertinent exposure data 2836 or updating data, etc., to RFID device 2820 on the disc. Monitoring unit 2804 can alternatively or additionally store such data 2836 internally in a suitable memory 2840 and/or upload the data to a data store 2844 of shared software application 2812 for tracking/redundant tracking. Writing exposure data 2836 to RFID device 2820 on chemical indicator disc 2808 can be useful, for example, if the disc is later used with another monitoring unit that is not in communication with shared software application 2812, among other reasons. Those skilled in the art will readily understand that the physical components used in the example are merely illustrative and that other physical components that provide the same or similar functionality can readily be substituted with no undue experimentation.

With continual tracking of exposure of chemical indicator disc 2808 to light from monitoring unit 2804, which due to its intensity, can typically be considered to be at least the majority of light to which the disc is exposed over time, exposure data 2836 can be compared to known benchmark photo-aging data 2848 determined, for example, in a laboratory for like chemical indicators, and any adjustments to the reading data acquired from the aged chemical indicators 2816 can be made as needed. Such adjustments can be made internally within monitoring unit 2804, by shared software application 2812, or both. A benefit to having adjustments

made by shared software application **2812** is that benchmark photo-aging data **2848** can be updated and/or newly added easily at a central location without the need to provide the revised data to each of the monitoring units, such as monitoring unit **2804** and other monitoring units **2852(1)** to **2852(N)**, that utilize the shared software application.

Another way of compensating for aging of a chemical indicator is to use redundant light sources having the same wavelength profiles but that provide differing brightness levels. In this manner, the differing regions of a chemical indicator exposed to the light of differing brightness will photo-age at differing rates. For example, FIG. **29** illustrates a chemical indicator **2900** that is divided into first and second aging regions **2904(1)** and **2904(2)**. In first aging region **2904(1)**, chemical indicator **2900** is exposed to illumination of brightness x , which is applied at each of illumination spots **2908(1)** to **2908(5)**. However, in second aging region **2904(2)**, chemical indicator **2900** is exposed to reduced-brightness illumination x/y (wherein $y > 1$), which is applied at each of illumination spots **2912(1)** to **2912(5)**. While the value of y can be any in the range noted above, simple examples include $y=2$ and $y=3$, such that brightness in second aging region **2904(2)** would be one-half and one-third, respectively, of the brightness of the illumination in first aging region **2904(1)**. These examples are merely illustrative and not limiting.

FIG. **30** is an exemplary graph **3000** of optical reading intensity (e.g., digitizer counts) versus parameter value for a particular chemical indicator. In the example shown, the parameter is the pH level of the water. In graph **3000**, “New x ” curve **3004** indicates the reading intensity over a range of the parameter when the chemical indicator is new and exposed to measurement illumination of brightness x . As can be seen, the region **3004(1)** of curve **3004** is the most useful part of the curve, since changes in the parameter in this region result in the greatest changes in the reading intensity. Thus, in this example, the chemical indicator would be most useful for monitoring pH in the range of about pH 4.5 to pH 7.5. However, “Aged x ” curve **3008** indicates the reading intensity over the range of the parameter when the chemical indicator is aged a certain amount and exposed to measurement illumination of brightness x . As can be seen by comparing curves **3008** and **3004**, as chemical indicator ages, the intensity of the readings at brightness x is reduced.

Similarly, “New $x/3$ ” curve **3012** and “Aged $x/3$ ” curve **3016** indicate, respectively, the reading intensity over the range of parameter when the chemical indicated is new and aged a certain amount and exposed to measurement illumination of brightness $x/3$, i.e., illumination that is one-third the brightness of x . A drawback of using light of reduced brightness is that there can be quite a bit more noise than if a higher brightness is used. This noise is seen in curves **3012** and **3016** in the form of the undulations of the curves. However, it can be seen that the reading intensities of both the new and aged readings at reduced brightness $x/3$ are substantially the same as the intensity of the new readings at brightness x . This information, and knowing benchmark aging profile data for brightness x (such as “Aged x ” curve **3008**) can be used to make adjustments to the measurement readings over time as the chemical indicator ages. Benefits of using this procedure is that historical light exposure data is not needed and it accounts for light exposure, such as ambient light exposure during use and/or during periods of nonuse, storage, etc. As noted above, these adjustments can be desirable to increase the accuracy of the measurements provided to a user and/or to increase the likelihood that the

water being monitored is receiving the proper dosing and is remaining within its target quality tolerances.
Friction Testing

When a chemical indicator apparatus is driven to multiple reading positions using a coupling having significant play, such as a magnetic coupling, friction between the chemical indicator apparatus and the support structure(s) with which it is engaged can be so great that the monitoring system/unit may “believe” it is reading one chemical indicator when it is actually reading another. As an illustration, envision that chemical indicator disc **2500** of FIG. **25** is engaged with monitoring unit **812** of FIG. **8** and is driven by the magnetic coupling illustrated in FIG. **9**. As can be seen in FIG. **25**, chemical indicators **2500** and **2520** are relatively close together, and if enough friction is present, monitoring unit **812** (FIG. **8**) could be “thinking” it is taking a reading on chemical indicator **2500**, when friction has interfered with the rotation of disc **2508** to the extent that the reading at issue is actually from chemical indicator **2520**, assuming a clockwise rotation of the disc as seen in FIG. **25**.

One way that monitoring unit **812** (FIG. **8**) can determine how much friction is present between disc **2508** and the monitoring unit is to take readings in both a clockwise direction and a counterclockwise direction, correlate the readings to one another, and analyze the correlation data. This is illustrated with FIGS. **31** to **34**. Referring to these figures as noted, and also to FIG. **25** where indicated, FIG. **31** is a graph **3100** of reading intensities versus stepper motor position for readings taken while driving chemical indicator disc **2508** (FIG. **25**) in a clockwise direction relative to FIG. **25**. While readings are taken at discrete stepper motor positions, the curve **3104** in graph **3100** is a fitted curve fitted to the data points. Region **3108** of curve **3104** corresponds to readings taken from chemical indicator **2520** (FIG. **25**) and region **3112** of the curve corresponds to readings taken from chemical indicator **2500**. Region **3116** of curve **3104** corresponds to readings taken at space **2524** (FIG. **25**) between chemical indicators **2520** and **2500**. In this example, holder **2528** (FIG. **25**) is made of black plastic, which is exposed at space **2524**, so the intensities of the readings are low because of the high absorbance of the black plastic to the illuminating light.

FIG. **32** is a graph **3200** of reading intensities versus stepper motor position for readings taken while driving chemical indicator disc **2508** (FIG. **25**) in a counterclockwise direction relative to FIG. **25**. As with curve **3104** of FIG. **31**, curve **3204** of graph **3200** is a fitted curve fitted to the data points. Region **3208** of curve **3204** corresponds to readings taken from chemical indicator **2520** (FIG. **25**) and region **3212** of the curve corresponds to readings taken from chemical indicator **2500**. Region **3216** of curve **3204** corresponds to readings taken at space **2524** (FIG. **25**) between chemical indicators **2520** and **2500**, which, again is black plastic in this example. Those skilled in the art will understand that the stepper motor positions shown in graphs **3100** and **3200** are absolute and not directional. Therefore, assuming the stepper motor positions increase as disc **2508** is rotated in a clockwise direction, the readings of graph **3100** of FIG. **31** are taken in the stepper motor position order **16**, **17**, **18**, **19**, etc., and the readings of graph **3200** of FIG. **32** are actually taken in reverse order, for example, **28**, **27**, **26**, **25**, etc.

Once intensity data has been obtained for readings taken in both the clockwise and counterclockwise direction, such as the data illustrated, respectively, by graphs **3100** and **3200**, the data can be compared, for example, using a cross-correlation function that compares the data points at

each stepper motor position and finds the differences between them to provide an error for that position. Indeed, the amount of friction, in terms of stepper motor positions, can be determined, for example, by shifting one of curves 3100 and 3200 relative to the other in one-step increments in both directions and calculating the sum of the errors at each stepper motor position. When the two curves are at their position of greatest alignment, the sum of the errors at that stepper motor position will be at a minimum. With due noting of the stepper position offset at which the minimum sum of errors occurs, the collected data can be adjusted accordingly. As can be readily appreciated, where the reading intensities in the two directions are the same or substantially the same at each and every position and the readings are taken very close to one another in time so that differences due to changes in the water parameter being measured can be neglected, then there is little to no friction in the system. This is illustrated by error curve 3300 of FIG. 33 where the error is nearly zero at zero offset, indicating that friction is not an issue. In contrast, error curve 3400 of FIG. 34 illustrates a situation in which friction is present. As can be seen in FIG. 34, in region 3404 of error curve 3400, which is at about an offset of five stepper positions, the cumulative error in intensity readings is relatively small, indicating that friction is causing the data collected in the two opposing directions to be about five stepper positions off from one another.

It is noted that if the monitoring system/unit determines that the friction and corresponding lag is excessive, it can take any one or more of a number of actions, such as: 1) attempting to solve the friction problem (e.g., in a disc-based example, by spinning the disc rapidly in one or both directions and performing another friction analysis after such spinning); 2) warning a user that the friction is too great; and 3) instructing a user to remove the chemical indicator apparatus (e.g., disc) from the monitoring system/unit, clean the contacting parts of the chemical indicator apparatus and monitoring system/unit; and 4) instruct a user to replace the chemical indicator apparatus or other part that may be causing the friction. It is noted that these actions may be performed in a certain sequence, such as action 4 being taken only after performing action 1 one or more times and after performing action 3 one or more times, among other sequences.

Dosing Protection/Action Matrix

Over time and for a variety of reasons, the readings/measurements taken by a water quality measuring/monitoring system/unit, such as any of such systems and units described in this disclosure, become less accurate. For example, reading error can be introduced due to any one or more of the following: 1) light output imbalance between "identical" light sources; 2) light source degradation over time; 3) chemical indicator photo-aging; 4) chemical indicator water-aging; 5) chemical indicator water-borne fouling; 6) optical system water-borne fouling; and 7) friction between a chemical indicator apparatus and a measuring/monitoring system/unit, among others. With so many sources of error and with the desire to reasonably ensure that the aquatic environment being measured/monitored is being properly measured/monitored and/or is receiving proper dosing of additives, it is desirable to determine the level of confidence that can be placed on the readings being taken at any point in time. By determining a confidence level, the measuring/monitoring system/unit can then take certain actions (or not) as the confidence level decreases (or uncertainty increases).

FIG. 35 depicts an exemplary action matrix 3500 for a set of error sources 3504. In this example, which is merely illustrative and should not be considered limiting, each error source 3504 is assigned to a row 3508 of matrix 3500, and each column 3512 corresponds to an uncertainty level 3516. Here, uncertainty levels 3516 range from "0" (i.e., effectively no uncertainty) to "3" (highest uncertainty), with the level being determined based on suitable information, such as photo-aging data, water-aging data, friction-test data, light-balance data, etc., that depends on the error source 3504 at issue. The various cells 3520 of action matrix 3500 are actions that the corresponding measuring/monitoring system/unit, such as any one of the measuring/monitoring systems/units described in this disclosure, takes relative to each of error sources 3504 for each uncertainty level 3516. For example, when optical system water-borne fouling 3504 (1) is the error source 3504 at issue, when the measuring/monitoring system/unit at issue determines that uncertainty level 3516 is a relatively low "1", then it may simply try to clean the optical system itself, such as by using a cleaning element (e.g. cleaning element 1904 of FIG. 19) onboard the system, such as on the chemical indicator apparatus. However, if the measuring/monitoring system/unit determined that uncertainty level 3516 for optical system water-borne fouling 3504(1) is moderate to high, i.e., "2" or "3", for example after attempting to self-clean the optical system, then the system/unit may issue an instruction (e.g., via a GUI) that instructs the user to remove the chemical indicator apparatus and clean it manually. As another example, when chemical indicator apparatus/monitoring unit friction 3504 (2) is the error source 3504 at issue, when the measuring/monitoring system/unit at issue determines that uncertainty level 3516 is a relatively low "1", then it may simply try to correct the friction problem. For example, if the chemical indicator apparatus is a disc, then the measuring/monitoring system/unit can spin the disc at a high speed for a certain amount of time. However, if the measuring/monitoring system/unit determined that uncertainty level 3516 for friction 3504(2) is moderate to high, i.e., "2" or "3", for example after attempting to self-correct the friction problem, then the system/unit may issue an instruction (e.g., via a GUI) that instructs the user to remove the chemical indicator apparatus and clean the faying surfaces manually. Of course, these examples are only illustrative, and those skilled in the art will readily be able to develop an action matrix for any particular embodiment and application.

As mentioned above, it is desirable to have a certain level of confidence in the measurements/readings that a given measurement/monitoring system/unit is making to inhibit improper dosing of the water in the aquatic environment that is being measured/monitored. Because errors can be cumulative, it can be desirable to calculate an overall dosing confidence value based on the uncertainty levels for multiple error sources. In addition, because some error sources may not be as important to determining an overall dosing confidence value as others, any dosing confidence formula can include weighting. Following is an example of a formula that can be used to calculate a dosing confidence value, C:

$$C = w_1 U_1 + w_2 U_2 + w_3 U_3 + \dots + w_n U_n \quad (1)$$

wherein:

U_n is the uncertainty level for a particular error source, such as one of uncertainty levels 3516 for any one of error sources 3504 of FIG. 35; and

W_n is a weight indicating the importance of the corresponding error source in the determination of the dosing confidence value C.

As will be readily appreciated, with this formula using the value of uncertainty level **3516** of FIG. **35** for uncertainty levels and using positive real numbers for weights, the higher the dosing confidence value *C*, the lower the confidence that the dosing instructions (e.g., automated dosing instructions **2428** and/or assisted dosing instructions **2468** of FIG. **24**) are correct. In an attempt to prevent improper dosing that may severely negatively impact the aquatic environment, for example, by killing fish, killing plants, killing coral, etc., if the measurement/monitoring system/unit determines that the calculated dosing confidence value *C* exceeds a predetermined threshold, then the system/unit may stop issuing dosing instructions altogether and/or issue one or more alerts, for example, via a GUI for the system/unit, providing one or more warnings to a user, such as that the monitoring system/unit will no longer issue dosing instructions, the monitoring system/unit should be checked, etc. Those skilled in the art will be able to determine a suitable threshold for a given situation. Those skilled in the art will also readily understand that Equation (1) for the determination of a dosing confidence value is merely illustrative and that any of a variety of other formulas can be used.

Dosing Rate Protection

Depending on the type of aquatic environment at issue, when dosing is needed, there may be limits imposed on how quickly one or more dosing additives should be added to the water. For example, for some species of fish, rapid changes in the pH of the water can cause inflammation of gill membranes. In some cases, the reaction to the rapid change can be so severe that the fish's ability to breathe is severely inhibited and death can result. In another example, if the aquatic environment is a saltwater-based coral environment and the water is at or near its carbonate/calcium saturation point, then adding calcium too quickly to the water can cause the precipitation of calcium carbonate, the effect of which is to undesirably reduce the level of those constituents. In both of these examples, as with many other examples that those skilled in the art will be familiar with or otherwise understand, it is desirable to avoid negative effects by ensuring that dosing is performed at a rate that the negative consequences, such as the gill inflammation in the first example and the calcium carbonate precipitation in the second example, do not occur.

In order to avoid the negative consequences for any particular aquatic environment and dosing situation, a dosing calculator of the present disclosure, such as any of dosing calculators **120** (FIG. **1**), **240** (FIGS. **2**), and **2436** (FIG. **24**), can make intelligent dosing rate decisions based on appropriate information about the aquatic environment and provide either automated dosing instructions and/or assisted dosing instructions, such as automated dosing instructions **2428** and **2468** of FIG. **24**, respectively, based on those decisions. In this connection, a user interface, such as a GUI **3600** illustrated in FIG. **36** can be provided to allow a user to select/input any information that the dosing calculator would need to know in order to calculate dosing rate limitations for any one or more of the additives that may need to be added to the aquatic environment. As those skilled in the art will readily appreciate, any user interface provided for this purpose can be configured in any one or more of a variety of manners to allow a user to enter the necessary information. For example, the user interface can include one or more selection devices (hardware and/or software), such as drop-down menus, radio buttons, check boxes, etc., that allow a user to input the necessary information.

For example, GUI **3600** of FIG. **36**, which is for a relatively large-screened computing device, such as a tablet computer, a laptop computer, or a desktop computer, includes 1) a drop-down water-type selector **3604** that allows the user to select the water type, 2) a dosing method selector **3608** that allows the user to indicate the method of dosing, 3) a drop-down doser make/model selector **3612** that allows the user to input the doser being used, if any, 4) a number of additive selectors **3616(1)** to **3616(N)** that each allow the user to select the brand/type of each additive available for adding to the water, and 5) one or more supported species selectors, here, selectors **3620(1)** and **3620(2)** for fish species and coral species, respectively. It is noted that one or more of the selectors **3612**, **3616(1)** to **3616(N)**, **3620(1)**, and **3620(2)** can be dynamically generated based on selections made on one or more other selectors. For example, doser make/model selector **3612** may only be displayed when either the "AUTO" or "ASSISTED/DOSER" are selected, fish species selector **3620(1)** may be populated with only the species of fish compatible with the water type selected (e.g., only freshwater fish are displayed when "FRESH" is selected), the coral species selector **3620(2)** may appear only if "SALT W/CORAL" is selected, and the number and type of additive selectors **3616(1)** to **3616(N)** displayed can be based on, for example, the water type selected alone or in combination with one or more of the fish and coral species selected. Once the user has input all of the appropriate parameters, they can be stored as aquatic environment parameters **3624** in a suitable data store **3628**. A properly programmed dosing calculator **3632** can use aquatic environment parameters **3624**, along with a knowledge base **3636** of known problems that arise with dosing too fast and corresponding dosing rates that avoid those problems, to determine one or more proper dosing instructions **3640** that avoid the relevant excessive-dosing-rate problem(s). As mentioned above, dosing instructions **3640** can be of the automated dosing type, assisted dosing type, or both, like dosing instructions **2428** and **2468** of FIG. **24**.

Confidence Levels Generally

As discussed above, a confidence level in one or more measurements by a measurement/monitoring system/unit may be influenced by one or more errors (i.e., adverse conditions) in aquatic environment monitoring and/or dosing system. Examples of adverse conditions that may influence a confidence level in one or more measurements include, but are not limited to, of a degradation in a chemical indicator due to photo-aging, a degradation in a chemical indicator due to water-aging, a physical contamination of a chemical indicator, an illumination imbalance related to an optical reader, a degradation of a light source of an optical reader, a physical contamination in water between an optical reader and a chemical indicator, a displacement due to friction between a chemical indicator apparatus and a monitoring unit, an error intrinsic in a chemical indicator, an error in distance between a chemical indicator apparatus and an optical reader, and any combinations thereof. In one exemplary aspect, one or more measured values for one or more errors/conditions can be used to determine a confidence level for a measurement taken from a chemical indicator. Different ways to measure error/conditions are discussed throughout the current disclosure. In one example, a determination of a confidence level and/or generation of instructions for correcting the condition (e.g., automatically acting to correct the condition using one of the components of a aquatic environment monitoring/dosing system according to the current disclosure, alerting a user to the condition, such

that the user may act to correct the condition, discarding data, etc.) can be executed by a dosing calculator or other component of an aquatic environment monitoring and/or dosing system.

In certain examples, when a value of a confidence level exceeds a threshold (e.g., a threshold stored in a memory associated with an aquatic environment monitoring and/or dosing system as discussed herein) or moves to a position of interest, a confidence adjustment can be generated (e.g., by a dosing calculator or other processing component of a system). A confidence adjustment can be used to instruct an action. Example actions include, but are not limited to, actions by a monitor device, actions by a dosing device, actions by another component of the system, actions by a user of the system, and any combinations thereof. Additionally, an action or an instruction to take an action related to correcting a condition of a component of the system can occur to correct one or more of the errors/adverse conditions discussed herein. For example, a measured value for a constituent of an aquatic environment (e.g., calcium, magnesium, pH, carbonate, etc.) may be modified based on a confidence value. Other examples include, but are not limited to, providing an alert or other instruction to a user (e.g., via a graphical user interface), automatically addressing an adverse condition, changing a rate of dosing, providing a modified assisted dosing instruction, and any combinations thereof.

Several ways of utilizing a confidence level are discussed above (e.g., with respect to an action matrix, such as the action matrix shown in FIG. 35; with respect to Equation (1) discussed above for combining confidence level values for a plurality of errors/conditions. In other examples, confidence level data may be plotted and/or measured over time for a plurality of data readings to show trends in confidence for the readings over that time period. FIG. 37A illustrates an example of pH measured data over a four week time (top graph of the figure) with corresponding confidence level data (lower graph of the figure). In this example, pH values are obtained using a plurality (e.g., ten) optical spot readings on a chemical indicator, such as is discussed above with respect to FIG. 29. At each time interval a plurality of pH values are obtained with the upper value of the plurality of values plotted over time as line 3705 and the lower value of the plurality of values plotted over time as line 3710. Where the upper value line 3705 and lower value line 3710 are closer together, the range of values measured from the multiple optical spots on the chemical indicator is small. Where the upper value line 3705 and lower value line 3710 deviate from each other, such as at location 3715 (where the lower values deviate greatly from the upper values) and at location 3720 (where the upper values deviate greatly from the lower values), the range between the values measured from the multiple optical spots on the chemical indicator is large. A large range can be an indication of an obstruction or other error condition in one or more regions of the chemical indicator. The lower confidence plot in the figure shows confidence level in the measurements in percentages. Where the range of measured pH values differ greatly, the confidence is shown to decrease (such as at locations in time 3715 and 3720). The lower confidence plot also shows a 100% confidence level 3725 (indicated by the horizontal dotted line) and a confidence threshold indicated by the dotted line 3730. Confidence values below the confidence threshold 3730 may trigger one or more actions, as discussed above (such as alerting a user, discarding one or more measured values, automatically taking action (e.g., changing a rate of

dosing, stopping dosing, spinning an indicator disc at a high rate of speed, engaging a cleaning mechanism to clean an optical reader optic, etc.))

The lower confidence plot also shows a sloping dotted line 3735 illustrating the decreasing confidence in measurements over time (e.g., due to known photo aging, aging of a chemical indicator due to water exposure, etc.). Thus, in this example, confidence values decrease with variations in the range of pH values and also decrease steadily over time. Due in part to the decreasing confidence over time, the likelihood of exceeding the threshold line 3730 increases with time in this example.

Confidence levels may also be influenced by measured data that changes rapidly over time. A rapid change surrounded by steady data values can be indicative of a sudden change in environment, such as may be caused by a contaminant or other error condition in the monitoring system. FIG. 37B illustrates another example of plotted confidence values. In this example, pH values each measured at one location on a chemical indicator (or alternatively an average of multiple measurements) at each iteration in time is plotted 3750 over a time of approximately 60 minutes. In this example, confidence levels (in the lower plot) are shown to decrease when the pH data has a rapid rate of change over time, such as at locations 3755, 3760, and 3765.

Exemplary Enhancing Features and Alternatives

This section presents various features that can enhance any of the systems and/or components thereof, as well as alternatives to various parts of one or more of those systems and components. It is noted that each of the features and alternatives described herein need not necessarily be implemented in conjunction with any particular system or component of the present disclosure, but rather can be implemented separately so as to include only the necessary supporting features and elements.

Linear Combined I/LC and Line Camera

FIGS. 16 and 18 illustrate combined I/LCs 1600 and 1800, respectively, that are generally circular in form. FIG. 38, however, illustrates a combined I/LC 3800 that utilizes the same components as combined I/LCs 1600 and 1800, but uses them in a linear form. As seen in FIG. 38, combined I/LC 3800 includes two linear spot lensings 3804(1) and (2) and a central linear light collector 3808 located between the two spot lensings. Depending on the number and configuration of the light sources (here, linear light sources 3810(1) and 3810(2)) used, each spot lensing 3804(1) and 3804(2) can be used to form a plurality of discrete spots 3812(1) to 3812(6) of light on a suitable target 3816 (such as a chemical indicator having a length that is equal to or greater than the length of combined I/LC 3800) or a continuous line-shaped "spot" 3820(1) and 3820(2) of light along the length of that spot lensing. In the case of individual discrete spots, the size and location of spots 3812(1) to 3812(6) can be carefully controlled by selecting the proper target distance between combined I/LC 3800 and target 3816 and carefully designing the optics of each of spot lensing 3804(1) and 3804(2) so that the discrete beams 3824(1) to 3824(6) of light converge at the proper focal points 3828(1) to 3828(3), as described above relative to FIG. 16. In the case of elongated light sources that provide line-spots 3820(1) and 3820(2), the width, W, of each of the lines can be carefully controlled in the same manner. Central light collector 3808 can be designed using the same principles described above relative to central light pipe 1644 of FIG. 16 so that the light collected from spots 3812(1) to 3812(6) or 3820(1) and 3820(2) is maximized and conducted to one or more light

sensors, here, a single line camera **3832**, with or without one or more intervening light filters **3836**, as needed.

In one example, the light source(s) corresponding to spot lensing **3804(1)** can be of one wavelength and the light source(s) corresponding to spot lensing **3804(2)** can be of another wavelength. This would allow for the use of a ratio or reference wavelength, as discussed above in the context of reference illumination relative to FIG. **25**, to assist in the calibration of readings taken by line camera **3832** or other sensor(s) that may be used. Use of linear camera **3832**, such as a linear charge-coupled device (CCD), can enable fine resolution in the process of scanning the surface of target **3816** such that small imperfections and contaminations of the target (e.g., chemical indicator) can be identified and isolated during the data analysis process. A linear combined I/LC, such as combined I/LC **3800** of FIG. **38** can also help a cleaning element, such as a bristled element, be more effective since the bristles will all be hitting a surface that is at the same height at the same time and, therefore, will have more uniform forces along the bristles as they glide over top of the light pipe. It is noted that the linear elongated shape of combined I/LC **3800** is merely illustrative and that other elongated shapes, such as laterally curved, wavy, zig-zag, and ring-shaped, among many others, are possible.

Apparatus for Ambient Light Analysis

FIG. **10** illustrates a chemical indicator disc (FF**16**) that fits, for example, monitoring unit **812** of FIGS. **8** and **9**. As described above, disc **816** of FIG. **10** includes ten chemical indicator patches **1004(1)** to **1004(10)** for taking readings indicative of various levels of parameters of the water in which the disc is submerged during use, such as water **804** of FIG. **8**. In some applications, such as aquarium monitoring, it is desirable to know the quality of the light(s) being used with the aquarium. Light sources can degrade over time, resulting in decreased light quality over time. An optically based chemical indicator monitoring/measuring system/unit of the present disclosure can readily be adapted to take readings of the ambient light in the particular aquatic environment at issue.

In one embodiment using monitoring unit **812** of FIGS. **8** and **9** as an example, when ambient light readings are desired, a user can temporarily replace chemical indicator disc **816** with a similar disc, but which has various translucent color filters in place of various ones of chemical indicator patches **1004(1)** to **1004(10)**. Each color filter, which could be a gel-type filter, among others, would permit a different set of wavelengths of the ambient light to pass through. In this manner, one or more optical readers aboard monitoring unit **812**, such as reader system **400** of FIG. **4**, can be used to take intensity readings of the filtered light passing through one or more of the translucent color filters. Monitoring unit **812** could then use the information about the ambient light collected using all of the color filters to analyze the spectral makeup and brightness of the ambient light. A purpose of making these spectral and brightness analyses is to ensure that coral and/or plants in the aquatic environment have optimum light conditions for photosynthesis. This special ambient light analysis disc could be used, for example, every month or so to check the quality of the light being used. Replacing each of patches **1004(1)** to **1004(10)** of FIG. **10** with a unique color filter relative to the other filters provided on the disc would provide ten different light filters. This will typically be enough to perform a good spectral analysis. However, if more filters are needed, any of a number of modifications could be made, such as splitting each patch location into two or more different color filters.

Stationary Magnetic Element Disc Drive

FIG. **39** illustrates a stationary-magnet-element disc drive **3900** that can be used in a rotary-type monitoring/measuring system/unit of the present disclosure, such as in the place of the stepper motor arrangement illustrated in FIG. **22**. Referring to FIG. **39**, disc drive **3900** includes a plurality of magnetically switchable magnet elements **3904** (only a handful labeled for convenience (e.g., electromagnets, rotatable magnets, magnets having movable magnetic shields, etc.) that are individually switchable to change polarity, to change the location of the poles, and/or to change the magnetic state (e.g., from non-polarized to polarized). Each magnetic element **3904** is located at a fixed location (i.e., stationary (note that the magnetic element could be moveable in place in some embodiments) on a monitoring/measuring unit **3908** and is capable of magnetically coupling with a disc **3912**, such as a chemical indicator disc or an ambient light analysis disc, that includes one or more corresponding magnets, here magnets **3916(1)** to **3916(4)**. As those skilled in the art can readily appreciate, monitoring unit **3908** can include a suitable controller **3920** that is configured, for example, via software and/or hardware, to control the states of magnetic elements **3904** so that their interaction with magnets **3916(1)** to **3916(4)** causes disc **3912** to rotate about its central rotational axis **3924**. The number and arrangement of the magnetic elements, as well as the switching scheme implemented, can be varied to achieve the desired number of steps in a full revolution of disc **3912**. In one example, the arrangement and controlling of the magnetic elements could be executed to create the small incremental steps described above in connection with the multi-reading scheme of FIG. **25**.

Cylindrical Chemical Indicator Apparatus and Monitoring/Measuring Therefor

FIG. **40** illustrates a monitoring/measuring system **4000** that includes a chemical indicator apparatus that is in the form of a chemical indicator cylinder **4004**. Cylinder **4004** has a plurality of longitudinal chemical indicators, of which **4008(1)** to **4008(3)** are visible in FIG. **40**. Each of these indicators can be any one of the chemical indicator types described above, or other type that will be known to those skilled in the art. In this embodiment, chemical indicators **4008(1)** to **4008(3)** are optically readable, for example, in any of the manners noted above, and they are read using a reader (not shown) having a linear combined I/LC **4012**. As those skilled in the art will readily appreciate, combined I/LC **4012** can be similar to linear combined I/LC **3800** of FIG. **38**, including having all of the appurtenances described in connection therewith, such as line camera **3832**, filter(s) **3836** and other features. In this example, cylinder **4004** of FIG. **40** includes a holder **4016** that supports the chemical indicators. For convenience, a handle **4020** is attached to holder **4016** to allow a user to readily handle cylinder **4004**, especially during insertion and removal of the cylinder from a corresponding monitoring/measuring unit **4024**. Although not shown, monitoring/measuring unit **4024** can include any one or more of the features described above with respect to other monitoring/measuring units, including unit **2202** of FIG. **22** and unit **2300** of FIG. **23**, among others. In addition, cylinder **4004** can include any one or more of the features described above relative to other chemical indicator apparatuses, including, for example, flow promoting features (passages, fins, etc.) for promoting the flow of water around the chemical indicators, one or more cleaning elements for cleaning combined I/LC **4012**, and replaceable elements for replacing individual ones or groups of the chemical indicators, among others. In addition, monitoring/measuring sys-

tem **4000** can be used in any of the automated dosing, assisted dosing, monitoring, and measuring systems described herein.

Chemical Indicator Apparatuses Having Replaceable Elements

Each of the chemical indicator apparatuses shown in the drawings up to this point of the disclosure suggest that the chemical indicators on each of those apparatuses are fixed. Thus, even if only one or fewer than all of the chemical indicators on a particular apparatus have aged to the point that they should no longer be used, a user's only option to restore reading accuracy and reliability to overcome this aging is to replace the entire apparatus. However, in some cases it would be desirable to have chemical indicator apparatuses wherein the chemical indicators can be individually replaced and/or replaced in groups for any of a variety of reasons. In addition to being able to use slower-aging chemical indicators for longer periods of time before replacement, providing chemical indicator apparatuses with replaceable chemical indicators allows, for example, for the replacement of damaged indicators (such as an indicator that is accidentally scratched while being handled) and for modifying a particular apparatus for reading a different set of water parameters than the apparatus was previously set up for.

FIG. **41** illustrates a chemical indicator apparatus **4100** having individually replaceable elements, two of which being illustrated in FIG. **41** as disengaged element **4104** and engaged element **4108**. Apparatus **4100** includes a holder **4112** that, in this example, is configured to receive up to eight individually replaceable elements in sectorized receivers **4116(1)** to **4116(8)**. In the embodiment shown, each element, such as elements **4104** and **4108**, is removably engaged with holder **4112** via a tab **4120** that engages, in this example, a corresponding one of eight like slots **4124(2)** to **4124(8)** so as to form an interference fit when the element is fully engaged with the holder, as is illustrated by element **4108**. Though not shown, each element is secured in place by a snap-lock latch tab on its underside (i.e., the side that faces the holder when properly engaged). In this example, the latch tab forms an interference fit with an edge **4128(2)** to **4128(8)** of a corresponding opening **4132(2)** to **4132(8)** and urges the radially inward end **4136(1)** and **4136(2)** into engagement with, in this case, a circular stop **4140** on holder.

In the example shown, element **4104** includes three chemical indicators **4144(1)** to **4144(3)** that can be of the same type or of differing types. Depending on the motivation for elementizing chemical indicator apparatus **4100** (e.g., for differing aging characteristics, adaption for differing water chemistries, etc.), the grouping of chemical indicators **4144(1)** to **4144(3)** can be selected accordingly. It is noted that while three chemical indicators **4144(1)** to **4144(3)** are shown, each element, including element **4104**, can have more or fewer chemical indicators and also/alternatively have one or more other features, such as one or more cleaning elements, one or more optical filters, one or more information containing devices, such as RFID tag **4148**, one or more indexing markings, such as optical markings **4152(1)** to **4152(3)**, etc. In this example, at least chemical indicator **4144(2)** is read by a corresponding optical reader **4156**, which can be any suitable optical measuring reader, such as any one of the optical readers described above. Optical indexing markings **4152(1)** to **4152(3)** are read by a corresponding optical indexing reader **4160**. Of course, other replaceable elements need not include any of these additional features, depending on the application at issue. Of

course, chemical indicator apparatus **4100** is merely illustrative of the many apparatuses that can be composed in an elementized fashion.

FIG. **42** illustrates a generally rectangular chemical indicator apparatus **4200** that includes a holder **4208** and one individually replaceable element **4212** engageable with a corresponding receiver **4216(1)**. As with the replaceable elements of apparatus **4100** of FIG. **41**, each replaceable element (of which only one **4212** is shown) can have any number of chemical indicators and/or other features, such as the other features described above with respect to FIG. **41**. In this example, though, element **4212** contains only a single chemical indicator **4220**. In this example, receiver **4216(1)** is uniquely keyed with key features **4224** designed and configured to receive only a complementarily keyed replaceable element, such as element **4212**, having complementary key features **4228**. In systems wherein the type of chemical indicator being read can only be determined by position, keying, for example via key features **4224** and **4228** shown, can be a way of ensuring that the proper chemical indicator is in the proper position. It is noted that the same or similar keying system can be used on a wide variety of chemical indicator apparatuses having replaceable elements, including chemical indicator apparatus **4100** of FIG. **41**. In the embodiment shown, element **4212** is held in position via a latch **4232** that engages a corresponding slot **4236** in the element. Other holding devices can be used in other embodiments.

In the view of FIG. **42**, holder includes a second receiver **4216(2)** for receiving a replaceable chemical indicator element (not shown) that is larger than element **4212** shown. The different size can be due to any one or more of a number of reasons, including enabling easy replacement of a group of chemical indicators having roughly the same aging characteristics, easy switching of a group of chemical indicators for one set of monitoring scenario for another monitoring scenario (e.g., fresh water to saltwater), and enabling easy replacement of a chemical indicator that needs to be larger than other chemical indicators, such as chemical indicator **4220**, among others.

Control of Flora and/or Fauna Growth Rates

FIG. **43** illustrates a setup **4300** that includes an aquatic environment **4304** that supports one or more aquatic life forms **4308**, the growth of which is/are controllable by controlling the amounts of one or more additives **4312(1)** to **4312(N)** added to the water **4316** in the aquatic environment. For example, if life form **4308** is coral, the growth rate of the coral can be controlled by controlling, for example, the amount of calcium added to water **4316**. As another example, if life form **4308** is a particular type of plant that has a growth rate dependent on the amount of carbon dioxide present in water **4316**, the amount of light, and/or the amount of fertilizer, then the growth rate of the plant can be controlled by controlling the amount of carbon dioxide and/or fertilizer added to the water and/or the amount of light provided to aquatic environment **4304**.

In this example, setup **4300** includes a monitoring system **4320**, which can be any one of the monitoring systems described herein or similar system utilizing one or more of the disclosed features. Setup also includes an auto-doser **4324** and a dosing calculator **4328** that generates dosing instructions **4332** based on water-quality measurements **4336** acquired via monitoring system **4320** and programmed-in parameters **4340** specific to aquatic environment **4304**, such as water type, fish species, water volume, coral species, plant species, etc. In operative communication with dosing calculator **4328** is a growth controller **4344**,

which in this example allows user to select the amount of growth that the user would like the coral (life form **4308**) to experience. As those skilled in the art will readily understand, the growth rate of coral is affected by calcium and alkalinity relative to the saturation limit of water **4316**. If calcium and alkalinity are kept a small amount below the saturation limit, the growth rate will be the fastest. However, if the free calcium (Ca^{2+}) is around 400 parts per million (ppm), the “growth” will be more of maintenance of the current growth rate. If the free calcium goes below about 400 ppm, for example, then the coral (life form **4308**) “growth” will be negative, i.e., the amount of coral will shrink. Growth controller **4344** allows the user to select the rate of coral growth desired and then modifies the dosing calculations that dosing calculator **4328** performs for the relevant parameter and additives. For example, if the user selects a fast growth rate, growth controller **4344** would cause dosing calculator **4328** to base its dosing calculations for calcium and alkalinity so that they remain close to the saturation point. In contrast, if the user selects a low or negative growth rate, growth controller **4344** would cause dosing calculator **4328** to base its relevant calculations on keeping the free calcium around or below 400 ppm.

To assist a user in setting a desired growth rate, growth controller **4344** may include a suitable UI **4348** that includes one or more controls **4352** that allow the user to select a desired coral growth rate. The one or more controls **4352** can take any of a wide variety of forms. For example, when UI **4348** is a GUI implemented in software, such as mobile computing device app **4356**, the one or more controls **4352** can be one or more soft controls, such as a slider **4360** that can be positioned adjacent the desired one of “Reduce”, “Maintain”, “Slow Growth”, and “Maximum Growth”. Alternatively, for example, slider **4360** can be replaced by a set of soft radio buttons (not shown) or a soft dial, among other things. If UI **4348** is hardware based, the one or more controls **4352** could be hard controls, such as a physical slider, physical radio buttons, physical dial, etc. As mentioned above, similar features can be implements for plants and/or any other life forms the growth of which can be regulated via controlling the dosing of one or more additives **4312(1)** to **4312(N)** added to the water **4316** and/or the amount of light provided to aquatic environment **4304**.

Social Networking and Targeted Marketing

As described above, some embodiments of the various systems of this disclosure are utilized in a cloud-computing environment. A cloud-computing environment can allow for providing software-based services to multiple subscribers to the services. In the context of the present disclosure, a cloud-computing implementation of water-quality monitoring systems can be configured to allow multiple subscribers, each with one or more water-quality monitoring systems, to become linked with one another, for example, via a social-networking platform. For example and in the context of aquariums, cloud-computing software for providing social networking and/or related services can be configured to receive information about each subscriber’s aquarium setup(s), including, but not limited to, any one or more of the following: tank size; water type; fish species; coral species; plant species; dosing additives, and type(s) of tank-support equipment, such as equipment for lighting, heating, filtering, pumping, dosing, etc. In addition, the cloud-computing software can also be configured to receive information from the subscribers’ water quality monitoring systems, including, but not limited to, any one or more of the following: aquarium conditions, such as chemical levels, temperature, light readings, pumping status; alarms and/or notifications,

such as alarms and/or notifications for out-of-tolerance water-quality conditions, monitoring systems errors and/or confidence levels (e.g., for chemical indicator photo-aging, chemical indicator water aging, indicator wheel friction, optics fouling, etc.); and dosing instructions, among others.

Using the forgoing and/or other information known to the cloud-computing software for multiple subscribers, the software can be configured to provide the subscribers with any one or more of a variety of useful functionalities. For example, the software may automatically group subscribers into one or more social groups based on any one or more of pieces of information that the software knows, such as any one or more of the pieces of information known about the subscribers’ setup and/or any one or more of the pieces of information known from the subscribers’ monitoring systems. As examples of automated grouping, the software may automatically assign subscribers to the one or more relevant groups or automatically notify subscribers of the relevant group(s) they may want to join. Examples of social groups include groups based on water type (e.g., brackish, saltwater, freshwater), groups based on species (e.g., coral, fish, plants, etc.), groups based on problems with setup (e.g., problems with maintaining calcium levels, problems with maintaining pH levels, problems with excess algae growth, problems with their monitoring systems, etc.) among many others. With such social grouping, subscribers that share one or more commonalities relating to their aquarium setups can also share their problems and their resolutions to those problems, share their dosing regimes, as well as other information, such as sharing photos, videos, and stories concerning their setups with others that may be interested because of the shared commonalities. In addition, when a subscriber to the cloud computing software wishes to chat with other subscribers of the online aquarium community, the software can be configured to automatically permit sharing of data, trends, fish species, etc., to enable other subscribers to understand the setup, problems, and/or successes of other users. In essence, such cloud-computing software marries physical data collection and diagnostics to social networking.

Regarding targeted marketing, any networked implementation of a monitoring system of the present disclosure can include a targeted-marketing feature that sends relevant advertising to a subscriber as a function of information known about that subscriber’s system, such as any one or more of the pieces of information noted above relative to the social networking features. In one example, if a problem or alert condition happens and a subscriber receives a notification via a smartphone or other method, they can also be target marketed for a solution to the issue they have. For instance, if the subscriber’s carbonate hardness is too low, the cloud application can suggest commercial additives that might correct their water issues. The manufacturers of these additives can bid on marketing space for specific product suggestions to end users of the system.

Exemplary Installations

As mentioned above, a monitoring/measuring system/unit of the present disclosure can be used in a wide variety of applications. Following are some exemplary installations of monitoring/measuring systems/units to illustrate the variety of differing applications and number of ways the various components of such systems/units can be configured to suit a particular application. Of course, the following installations are merely illustrative and, therefore, should not be taken as limiting the number and type of installation and system/unit configurations.

Plumbed-In System

FIG. 44 illustrates a monitoring system 4400 integrated into a watertight unit 4404 that can be inserted into plumbing (not shown) that is used to circulate water (illustrated by arrow 4408) within an aquatic environment (not shown, but could be, for example, any of the aquatic environments shown or mentioned herein). Monitoring system 4400 includes a chemical indicator apparatus 4412 that, when unit 4404 is closed, is free to rotate within a water chamber 4416 within the unit under the influence of water 4408 flowing through the unit. In this example, the flow of water 4408 provides the motive force that rotates apparatus 4412 during use for monitoring. In this connection, apparatus 4412 includes a holder 4420 that has a plurality of paddles 4424 that water 4408 strikes as it moves through unit 4404 so as to cause the holder to rotate about rotational axis 4428. While some embodiments can be designed carefully in conjunction with the flow of water 4408 so that the rotation of apparatus 4412 is suitable for readings to be taken, other embodiments may optionally include one or more speed/position control devices 4432, such as a caliper brake, an escapement mechanism, etc., that ensure that the proper speed and/or reading locations are utilized. As another alternative, monitoring system 4400 may also or alternatively include a speed sensing system 4436 that senses the rotational speed of apparatus and adjusts the acquisition of readings accordingly. Such a speed sensing system 4436 may include a rotary sensor system (not shown) or an indexed sensing system (e.g., optical, magnetic, etc.), among many others. Like other monitoring systems/units described herein, monitoring system 4400 includes one or more optical readers 4440 for taking one or more readings of each of the chemical indicators, here six chemical indicators 4444(1) to 4444(6) are shown. In this example, unit 4404 includes single water inlet 4448 and a single water outlet 4452, though other embodiments can contain more of either or both. The rotation of chemical indicator apparatus 4412 induces sufficient circulation of water within chamber 4416. While not shown, those skilled in the art will readily appreciate that monitoring system 4400 can be deployed in any suitable environment, such as any of the wireless, wired, networked, cloud-computing, standalone, etc., environments described herein with suitable modifications that will be clear to those skilled in the art after reading this entire disclosure.

Standard Aquarium Sump Setup

Various figures already described illustrate monitoring and/or dosing systems deployed in the context of aquariums. For example, FIGS. 8 and 24 describe various aquarium-centric setups in which the corresponding respective monitoring systems 812 and 2404 are submerged directly in the corresponding aquarium 808 and 2420, respectively. However, some aquarium setups, especially setups having larger aquariums, have sumps. In such cases, it can be desirable to deploy a monitoring system of the present disclosure in the sump. FIG. 45 shows an aquarium sump 4500 with a monitoring system 4504 positioned in the sump. In this example, monitoring system 4504 is the same as or similar to the monitoring system illustrated in FIG. 9 as comprising monitoring unit 812 and chemical indicator disc 816. However, it should be understood that monitoring system 4504 can be any other monitoring system described herein. That said, since the monitoring system of FIG. 9 is a partially submersible system, FIG. 45 illustrates a waterline 4508 that indicates the level of the water (not shown) that should be present in sump 4500 when monitoring system 4504 is operating. As can be seen and appreciated, waterline 4508 of

FIG. 45 corresponds to waterline 920 of FIG. 9. Those skilled in the art will readily understand that aquarium sumps vary in configuration and that sump 4500 is merely illustrative and, therefore, non-limiting.

5 Customized Aquarium Setup

FIG. 46 illustrates an aquarium setup 4600 having a tank 4604 that is "customized" to include features that enable implementing a monitoring system 4608 in which only the chemical indicator apparatus, here chemical indicator disc 4612, is submerged in the water 4616 within the tank. In this manner, all of the electronics 4620 and other components can be kept completely out of water 4616. In this example, the "custom" features include a recess 4624 formed within a wall 4628 (e.g., side wall or bottom wall) of tank 4604 that receives most or all of the components of the monitoring unit 4632 portion of monitoring system 4608. It is noted that in other embodiments, recess 4624 need not be so large (e.g., so that it does not include all or nearly all of monitoring unit 4632) or it need not be present at all, in which case monitoring unit 4632 would be on the outside of an otherwise flat wall. However, in the illustrated embodiment, with all components of monitoring unit 4632 located in recess 4624, a closure 4636 is provided to generally seal the monitoring unit in the recess. It is noted that closure 4636 can be integrated with monitoring unit 4632 such that its portions that engage wall 4628 can be flanges 4640 that can be used to secure the monitoring unit to tank 4604.

The "custom" features also include one or more combined I/LCs, here two combined I/LCs 4644(1) and 4644(2) that extend through corresponding respective openings 4648(1) and 4648(2) in wall 4628. Each combined I/LC 4644(1) and I/LC 46(2) is engaged with the corresponding opening 4648(1) and 4648(2) so that a watertight seal is created to keep water 4616 from entering recess 4624. Though not shown, other features can be provided through wall 4628, such as conductivity electrodes described elsewhere herein. It is noted that in other embodiments, the sealing member(s) can be of a different type. For example, the sealing member can be of an insert (not shown) that contains combined I/LCs 4644(1) and 4644(2) and that itself is sealingly inserted into an opening in wall 4628 within recess 4624. In the example shown, chemical indicator disc 4612 is rotatably engaged with a suitable receiver 4652 that is fixedly secured to wall 4628 and is driven by a magnetic coupling, for example, like either of the magnetic couplings illustrated in FIGS. 13 and 39. In this manner, monitoring unit 4632 can be removed entirely without any leakage of water 4616 into recess 4624. To inhibit ambient light from reaching the space 4656 between disc 4612 and wall 4628, disc 4612 includes an apron 4660 and the wall of tank 4604 includes a corresponding generally annular flange 4664. Features and aspects of each of monitoring unit 4632 and disc 4612 can be the same or similar to features and aspects of other monitoring units and chemical indicator apparatuses described herein.

55 Hidden Aquarium Monitoring System Setup

FIG. 47 illustrates an aquarium setup 4700 having an aquarium tank 4704 in which a monitoring system 4708 is hidden from view by an observer looking into the tank through at least a side wall 4712 of the tank. In this example, the concealment is due to the use of an aesthetic feature inside tank 4704, here an artificial tube coral structure 4716 that conceals a chemical indicator apparatus 4718 of monitoring system 4708 and an opaque tank stand 4720 that conceals a monitoring unit 4724 of the monitoring system. In other embodiments, a monitoring system can be concealed using one or more different types of aesthetic features within an aquarium tank and/or one or more different types

of external features. In addition, it is noted that in other embodiments, an entire monitoring system, such as monitoring system 2200 of FIG. 22, can be located within tank 4704 in place of just apparatus 4718. In that case, the only part on the outside of tank 4704, here in place of monitoring unit 4724 could be the inductive power source, for example, second transformer component 2270 of FIG. 22. Returning to FIG. 47, it is noted that monitoring system 4708 can be similar to monitoring system 4608 of FIG. 46 in that it can have one or more combined I/LCs 4728 (FIG. 47) integrated with a bottom wall 4732 of tank 4704. More generally, monitoring system 4708 of FIG. 47 can be the same as or similar to any other monitoring system described herein.

Non-Aquarium Closed-Loop Systems

While the foregoing setups focus on aquarium setups, monitoring and/or dosing systems of the present disclosure can be implemented in virtually any aquatic environment having a closed-loop circulation system. For example, FIG. 48 illustrates the deployment of a monitoring system 4800 of the present disclosure in an exemplary non-aquarium closed-loop setup 4804. In this example, setup 4804 includes one or more bodies of water 4908, such as a swimming pool, hot tub, pond, fountain, etc., in which the water is treated to maintain its clarity and/or healthfulness. Setup 4804 also includes a support system 4812 that includes plumbing 4816 and equipment for maintaining water 4808. In the embodiment shown, support system 4912 includes a circulation pump 4820 and a filter system 4824. In exemplary setup 4804, monitoring system 4800 is installed in an appropriate location within support system 4812, such as in plumbing 4816. In one example, monitoring system 4800 can be configured in a manner similar to plumbed-in system 4400 of FIG. 16. However, in other embodiments, monitoring system 4800 can be located elsewhere within setup 4804 in any suitable manner, such as within a component of filter system 4824, a part of circulation pump 4820, among many other locations. In addition, monitoring system 4800 can be the same as or similar to any of the other monitoring systems described herein.

In the embodiment shown, closed-loop setup 4804 optionally includes a dosing calculator 4828, which depending on how additives are dosed to water 4808 when needed, can generate automated dosing instructions 4832, assisted dosing instructions 4836, or both types of instructions. In this example, setup 4804 optionally includes an automated dosing system 4840 designed and configured to add one or more additives to water 4808 according to automated dosing instructions 4832. Depending on how many additives are needed to maintain the quality of water 4808 and how many of those additives auto-dosing system 4840 can dispense, the dosing of the water can be complemented, or not, by dosing performed manually either by hand or a manually controlled doser (not shown) based on assisted dosing instructions 4936. Various examples of automated dosing and assisted dosing instructions suitable for implementation as automated dosing instructions 4832 and assisted dosing instructions 4836 are described above. In addition, various ways in which dosing calculator 4828 can function and receive the various information needed for determining and generating automated dosing instructions 4832 and/or assisted dosing instructions 4836 are described above. All of the aspects and features described above relative to dosing calculators, automated dosing instructions, and assisted dosing instructions can be applied to dosing calculator 4828, automated dosing instructions 4832, and assisted dosing instructions 4836 of FIG. 48.

Open-Loop Systems

While the foregoing setups largely focus on closed-loop setups, monitoring/measuring and/or dosing systems of the present disclosure can be implemented in virtually any aquatic environment having an open-loop circulation system. For example, FIG. 49 illustrates the deployment of a monitoring system 4900 of the present disclosure in an exemplary open-loop setup 4904. In this example, setup 4904 includes monitored/measured water 4908, such as water in a domestic water distribution system, a wastewater treatment facility, an industrial processing process, etc. Setup 4904 also includes a feed-water system 4912 that includes plumbing 4916 and in some cases equipment (not shown) for processing water 4908. Examples of such equipment include but are not limited to filters, softeners, etc. In exemplary setup 4904, monitoring system 4900 is installed in an appropriate location within support system 4912, such as in plumbing 4916. In one example, monitoring system 4900 can be configured in a manner similar to plumbed-in system 4400 of FIG. 16. However, in other embodiments, monitoring system 4900 can be located elsewhere within setup 4904 in any suitable manner. In addition, monitoring system 4900 can be the same as or similar to any of the other monitoring systems described herein.

In the embodiment shown, open-loop setup 4904 optionally includes a dosing calculator 4920, which depending on how additives are dosed to water 4908 when needed, can generate automated dosing instructions 4924, assisted dosing instructions 4928, or both types of instructions. In this example, setup 4804 optionally includes an automated dosing system 4932 designed and configured to add one or more additives to water 4808 according to automated dosing instructions 4924. Depending on how many additives are needed to maintain the quality of water 4908 and how many of those additives auto-dosing system 4932 can dispense, the dosing of the water can be complemented, or not, by dosing performed manually either by hand or a manually controlled doser (not shown) based on assisted dosing instructions 4928. Various examples of automated dosing and assisted dosing instructions suitable for implementation as automated dosing instructions 4924 and assisted dosing instructions 4928 are described above. In addition, various ways in which dosing calculator 4920 can function and receive the various information needed for determining and generating automated dosing instructions 4924 and/or assisted dosing instructions 4928 are described above. All of the aspects and features described above relative to dosing calculators, automated dosing instructions, and assisted dosing instructions can be applied to dosing calculator 4920, automated dosing instructions 4924, and assisted dosing instructions 4928 of FIG. 49.

It is to be noted that the aspects and embodiments described herein may be conveniently implemented using one or more machines (e.g., one or more computing devices/computer systems that are part of an aquatic environment monitoring and/or dosing system) including hardware and special programming according to the teachings of the present specification, as will be apparent to those of ordinary skill in the computer art. Appropriate software coding can readily be prepared by skilled programmers based on the teachings of the present disclosure, as will be apparent to those of ordinary skill in the software art.

Such software may be a computer program product that employs a machine-readable hardware storage medium. A machine-readable storage medium may be any medium that is capable of storing and/or encoding a sequence of instructions for execution by a machine (e.g., a computing device) and that causes the machine to perform any one of the

methodologies and/or embodiments described herein. Examples of a machine-readable hardware storage medium include, but are not limited to, a magnetic disk (e.g., a conventional floppy disk, a hard drive disk), an optical disk (e.g., a compact disk “CD”, such as a readable, writeable, and/or re-writable CD; a digital video disk “DVD”, such as a readable, writeable, and/or rewritable DVD), a magneto-optical disk, a read-only memory “ROM” device, a random access memory “RAM” device, a magnetic card, an optical card, a solid-state memory device (e.g., a flash memory), an EPROM, an EEPROM, and any combinations thereof. A machine-readable medium, as used herein, is intended to include a single medium as well as a collection of physically separate media, such as, for example, a collection of compact disks or one or more hard disk drives in combination with a computer memory. As used herein, a machine-readable storage medium does not include a signal.

Such software may also include information (e.g., data) carried as a data signal on a data carrier, such as a carrier wave. Such a data signal or carrier wave would not be considered a machine-readable hardware storage medium. For example, machine-executable information may be included as a data-carrying signal embodied in a data carrier in which the signal encodes a sequence of instruction, or portion thereof, for execution by a machine (e.g., a computing device) and any related information (e.g., data structures and data) that causes the machine to perform any one of the methodologies and/or embodiments described herein.

Examples of a computing device include, but are not limited to, a computer workstation, a terminal computer, a server computer, a handheld device (e.g., tablet computer, a personal digital assistant “PDA”, a mobile telephone, etc.), a web appliance, a network router, a network switch, a network bridge, any machine capable of executing a sequence of instructions that specify an action to be taken by that machine, and any combinations thereof. In one example, a computing device may include and/or be included in, a kiosk. In another example, a dosing calculator (as discussed herein) may be associated with (e.g., be part of, be connected to, be included in, etc.) a computing device or any part thereof.

FIG. 50 shows a diagrammatic representation of one exemplary embodiment of a computing system 5000, within which a set of instructions for causing one or more processors 5004 to perform any one or more of the functionalities, aspects, and/or methodologies of the present disclosure. It is also contemplated that multiple computing systems may be utilized to implement a specially configured set of instructions for performing any one or more of the functionalities, aspects, and/or methodologies of the present disclosure in a distributed computing matter.

Computing system 5000 can also include a memory 5008 that communicates with the one or more processors 5004, and with other components, for example, via a bus 5012. Bus 5012 may include any of several types of bus structures including, but not limited to, a memory bus, a memory controller, a peripheral bus, a local bus, and any combinations thereof, using any of a variety of bus architectures.

Memory 5008 may include various components (e.g., machine-readable hardware storage media) including, but not limited to, a random access memory component (e.g., a static RAM “SRAM”, a dynamic RAM “DRAM”, etc.), a read only component, and any combinations thereof. In one example, a basic input/output system 5016 (BIOS), including basic routines that help to transfer information between elements within computing system 5000, such as during start-up, may be stored in memory 5008. Memory 5008 may

also include (e.g., stored on one or more machine-readable hardware storage media) instructions (e.g., software) 5020 embodying any one or more of the aspects and/or methodologies of the present disclosure. In another example, memory 5008 may further include any number of program modules including, but not limited to, an operating system, one or more application programs, other program modules, program data, and any combinations thereof

Computing system 5000 may also include a storage device 5024, such as, but not limited to, the machine readable hardware storage medium described above. Storage device 5024 may be connected to bus 5012 by an appropriate interface (not shown). Example interfaces include, but are not limited to, SCSI, advanced technology attachment (ATA), serial ATA, universal serial bus (USB), IEEE 1394 (FIREWIRE), and any combinations thereof. In one example, storage device 5024 (or one or more components thereof) may be removably interfaced with computing system 5000 (e.g., via an external port connector (not shown)). Particularly, storage device 5024 and an associated machine-readable medium 5028 may provide nonvolatile and/or volatile storage of machine-readable instructions, data structures, program modules, and/or other data for computing system 5000. In one example, software instructions 5020 may reside, completely or partially, within machine-readable hardware storage medium 5028. In another example, software instructions 5020 may reside, completely or partially, within processors 5004.

Computing system 5000 may also include an input device 5032. In one example, a user of computing system 5000 may enter commands and/or other information into computing system 5000 via one or more input devices 5032. Examples of an input device 5032 include, but are not limited to, an alpha-numeric input device (e.g., a keyboard), a pointing device, a joystick, a gamepad, an audio input device (e.g., a microphone, a voice response system, etc.), a cursor control device (e.g., a mouse), a touchpad, an optical scanner, a video capture device (e.g., a still camera, a video camera), touch screen, and any combinations thereof. Input device(s) 5032 may be interfaced to bus 5012 via any of a variety of interfaces (not shown) including, but not limited to, a serial interface, a parallel interface, a game port, a USB interface, a FIREWIRE interface, a direct interface to bus 5012, and any combinations thereof. Input device(s) 5032 may include a touch screen interface that may be a part of or separate from display(s) 5036, discussed further below. Input device(s) 5032 may be utilized as a user selection device for selecting one or more graphical representations in a graphical interface as described above.

A user may also input commands and/or other information to computing system 5000 via storage device 5024 (e.g., a removable disk drive, a flash drive, etc.) and/or network interface device(s) 5040. A network interface device, such as any one of network interface device(s) 5040 may be utilized for connecting computing system 5000 to one or more of a variety of networks, such as network 5044, and one or more remote devices 5048 connected thereto. Examples of a network interface device include, but are not limited to, a network interface card (e.g., a mobile network interface card, a LAN card), a modem, and any combination thereof. Examples of a network include, but are not limited to, a wide area network (e.g., the Internet, an enterprise network), a local area network, a telephone network, a data network associated with a telephone/voice provider, a direct connection between two computing devices, and any combinations thereof. A network, such as network 5044, may employ a wired and/or a wireless mode of communication. In general,

any network topology may be used. Information (e.g., data, software instructions **5020**, etc.) may be communicated to and/or from computing system **5000** via network interface device(s) **5040**.

Computing system **5000** may further include one or more video display adapter **5052** for communicating a displayable image to one or more display devices, such as display device(s) **5036**. Examples of a display device include, but are not limited to, a liquid crystal display (LCD), a cathode ray tube (CRT), a plasma display, a light emitting diode (LED) display, and any combinations thereof. Display adapter(s) **5052** and display device(s) **5036** may be utilized in combination with processor(s) **5004** to provide a graphical representation of a utility resource, a location of a land parcel, and/or a location of an easement to a user. In addition to a display device, computing system **5000** may include one or more other peripheral output devices including, but not limited to, an audio speaker, a printer, and any combinations thereof. Such peripheral output devices may be connected to bus **5012** via a peripheral interface **5056**. Examples of a peripheral interface include, but are not limited to, a serial port, a USB connection, a FIREWIRE connection, a parallel connection, and any combinations thereof.

General Disclosure Aspects

The systems, methods, apparatuses, software, etc. of the present invention have been exemplified by various exemplary embodiments and implementations as shown in the accompanying drawings and as described above. However, it should be understood that the discrete presentation of these embodiments and implementations should not be construed as requiring that: 1) these embodiments and implementations stand in isolation from one another; 2) that individual components, features, aspects, and/or functionalities described relative to each one of the embodiments and implementations cannot be used independently of the corresponding embodiment or implementation; and 3) that individual components, features, aspects, and/or functionalities described cannot be used individually in connection with other embodiments and implementations, either described herein or derivable therefrom, alone and/or in any combination with one another. On the contrary, those skilled in the art will appreciate that the individual components, features, aspects, and functionalities of a particular embodiment or implementation can, as appropriate under the circumstances, be utilized alone and in any subcombination with other components, features, aspects, and/or functionalities of that particular embodiment or implementation and with any other embodiment or implementation, including the specific examples described herein in connection with FIGS. **1** through **50**.

For example, it is noted that some implementations described above include a monitoring system, a dosing calculator, and a dosing system. However, in alternative embodiments of those implementations, only one or only two of the three components may be present. For example, some implementations may include only a monitoring system, other implementations may include only a dosing calculator, still other implementations may include only a dosing system, further implementations may include a monitoring system and a dosing calculator, still further implementations may include a dosing calculator and a dosing system, and yet still further implementations may include a monitoring system and a dosing system.

In other examples, specific components, features, aspects, and functionalities of chemical indicator apparatuses, such as shape of the holder, presence or absence of one or more cleaning elements, type of chemical indicator(s), number of

indicators, presence or absence of one or more water passages, presence or absence of one or more water filters, presence or absence of one or more light filters, presence or absence of a temperature sensor, presence or absence of one or more information storage devices, presence or absence of one or more position indicators, arrangement of indicator(s), etc., can be used on any chemical indicator apparatus that fall within the scope of the present disclosure, individually, or together within one another in any suitable combination or subcombination. In addition, any resulting chemical indicator apparatus made accordingly can be used with any suitably configured monitoring system that fall within the scope of the present disclosure, such as any one of the monitoring systems specifically illustrated in the accompanying figures and/or described above.

Similarly, any one or more of the robustness features, aspects, and functionalities described above, such as multi-read fault detection, fluorescent-reading contamination compensation, ambient light compensation, chemical indicator age compensation, friction testing, dosing protection, and dosing rate protection, among others, can be used individually and in any combination with one another and/or with any other suitable components, features, aspects, and functionalities, such as the components, features, aspects, and functionalities, described herein with respect to specific embodiments and implementations of non-robustness features, aspects, and functionalities. In addition, the robustness features, aspects, and functionalities can be used with any monitoring system, measuring system, and monitor falling within the scope of the present disclosure, including the specific monitoring systems, measuring systems, and monitors described herein.

Likewise, any one or more of the components, features, aspects, and functionalities of the exemplary enhancements and alternatives described above, such as a linear combined I/LC, an ambient light analysis apparatus, a stationary-magnet magnetic drive, a cylindrical chemical indicator apparatus, individually and group-wise replaceable chemical indicator elements, and growth-rate control, among others, can be used individually and in any combination with one another and/or with any other suitable components, features, aspects, and functionalities, such as the components, features, aspects, and functionalities, described herein with respect to specific embodiments and implementations of monitoring systems, measuring systems, monitors, chemical indicator apparatuses, and dosing calculators falling within the scope of the present disclosure, including the specific monitoring systems, measuring systems, monitors, chemical indicator apparatuses, and dosing calculators described herein.

Furthermore, it is noted that all of the forgoing description of the vastness of inter-combinability, combinations, and subcombinations of the various components, features, aspects, and functionalities of embodiments and implementations that fall within the scope of the present disclosure, including the specific examples of such described herein and illustrated in FIGS. **1-44** and **50**, is equally applicable to any of the specific setups described herein, including, but not limited to, standard aquarium setups, customized aquarium setups, hidden aquarium setups, non-aquarium closed-loop setups, and open-loop setups.

Exemplary embodiments have been disclosed above and illustrated in the accompanying drawings. It will be understood by those skilled in the art that various changes, omissions and additions may be made to that which is specifically disclosed herein without departing from the spirit and scope of the present invention. The following

67

claims include dependent claims for each independent claim that are shown without multiple dependencies. It is contemplated that each of the dependent claims for a given independent claim could alternatively be multiply dependent from any one or more of the preceding claims for that independent claim.

What is claimed is:

1. A method of monitoring errors in an aquatic environment monitoring system, the method comprising:

measuring a plurality of error values in the aquatic environment monitoring system using the environment monitoring system, each of the plurality of error values being an error value related to a condition selected from the group consisting of a degradation in a chemical indicator due to photo-aging, a degradation in a chemical indicator due to water-aging, a physical contamination of a chemical indicator, an illumination imbalance related to an optical reader, a degradation of a light source of an optical reader, a physical contamination in water between an optical reader and a chemical indicator, a displacement due to friction between a chemical indicator apparatus and a monitoring unit, an error intrinsic in a chemical indicator, an error in distance between a chemical indicator apparatus and an optical reader, and any combinations thereof;

determining a confidence level based on the plurality of error values;

comparing the confidence level to a threshold value associated with the aquatic environment monitoring system; and

generating a correction instruction based on said comparing using a dosing calculator associated with the aquatic environment monitoring system, the correction instruction for correcting a condition associated with the plurality of error values.

2. A method according to claim 1, wherein the aquatic environment monitoring system includes one or more chemical indicators on a chemical indicator holder and an optical reader configured for illuminating and reading the one or more chemical indicators.

3. A method according to claim 1, wherein said determining a confidence level includes using an error source action matrix.

4. A method according to claim 1, wherein said measuring a plurality of error values includes detecting a contamination between a chemical indicator apparatus and an optical reader of the environment monitoring system, said detecting a contamination including using one or more measurement illuminations and one or more reference illuminations of the chemical indicator apparatus by the optical reader.

5. A method according to claim 4, wherein the contamination between the chemical indicator apparatus and the optical reader includes a contamination selected from the group consisting of a contaminant on a chemical indicator of the chemical indicator apparatus, a contaminant on a surface of the optical reader, a contaminant in water between the optical reader and the chemical indicator apparatus, a physical defect in a chemical indicator of the chemical indicator apparatus, and any combinations thereof.

6. A method according to claim 1, wherein said measuring a plurality of error values includes referencing a stored expected value of a response from a chemical indicator with an actual detected value of a response from the chemical indicator; and determining an error value from the relationship of the stored expected value and the actual detected value.

68

7. A method according to claim 1, wherein said measuring a plurality of error values includes:

rotating a disc-shaped chemical indicator apparatus of the environment monitoring system in a clockwise direction and taking one or more clockwise readings from the chemical indicator apparatus with an optical reader of the environment monitoring system;

rotating the disc-shaped chemical indicator apparatus in a counter-clockwise direction and taking one or more counter-clockwise readings from the chemical indicator apparatus with the optical reader; and

correlating the one or more clockwise readings with the one or more counter-clockwise readings to generate a friction error value.

8. A method according to claim 1, wherein said measuring a plurality of error values includes determining an age of a chemical indicator of the environment monitoring system by referencing one or more stored values representing the amount of light illumination over time on the chemical indicator and/or referencing one or more stored values representing the amount of time the chemical indicator has been submersed in the water of the aquatic environment.

9. A method according to claim 1, wherein the correction instruction includes an instruction selected from the group consisting of an instruction to provide an alert to a user of the environment monitoring system to manually correct one or more error conditions, an instruction to the environment monitoring system to take an action to automatically correct one or more error conditions, an instruction to the environment monitoring system to stop automatically dosing one or more constituents to the aquatic environment, and any combinations thereof.

10. A method according to claim 1, wherein said determining a confidence level includes combining information related to the degradation of the chemical indicator due to aging with information related to a condition selected from the group consisting of a physical contamination of a chemical indicator, an illumination imbalance related to an optical reader, a degradation of a light source of an optical reader, a physical contamination in water between an optical reader and a chemical indicator, a displacement due to friction between a chemical indicator apparatus and a monitoring unit, an error intrinsic in a chemical indicator, an error in distance between a chemical indicator apparatus and an optical reader, and any combinations thereof.

11. A method according to claim 1, wherein the one or more error values include an error value related to an illumination imbalance related to an optical reader.

12. A method according to claim 1, wherein the one or more error values include an error value related to a displacement due to friction between a chemical indicator apparatus and a monitoring unit.

13. A method according to claim 1, wherein the one or more error values include an error value related to an error in distance between a chemical indicator apparatus and an optical reader.

14. A method according to claim 1, wherein the one or more error values include an error value related to a degradation of a light source of an optical reader.

15. A machine-readable hardware storage medium including machine-executable instructions for performing a method of monitoring errors in an aquatic environment monitoring system, the instructions comprising:

a set of instructions for measuring a plurality of error values in the aquatic environment monitoring system using the environment monitoring system, each of the plurality of error values being an error value related to

a condition selected from the group consisting of a degradation in a chemical indicator due to photo-aging, a degradation in a chemical indicator due to water-aging, a physical contamination of a chemical indicator, an illumination imbalance related to an optical reader, a degradation of a light source of an optical reader, a physical contamination in water between an optical reader and a chemical indicator, a displacement due to friction between a chemical indicator apparatus and a monitoring unit, an error intrinsic in a chemical indicator, an error in distance between a chemical indicator apparatus and an optical reader, and any combinations thereof;

a set of instructions for determining a confidence level based on the plurality of error values;

a set of instructions for comparing the confidence level to a threshold value associated with the aquatic environment monitoring system; and

a set of instructions for generating a correction instruction based on said comparing using a dosing calculator associated with the aquatic environment monitoring system, the correction instruction for correcting a condition associated with the plurality of error values.

16. A machine-readable hardware storage medium according to claim **15**, wherein the aquatic environment monitoring system includes one or more chemical indicators on a chemical indicator holder and an optical reader configured for illuminating and reading the one or more chemical indicators.

17. A machine-readable hardware storage medium according to claim **15**, wherein said set of instructions for determining a confidence level includes a set of instructions for using an error source action matrix.

18. A machine-readable hardware storage medium according to claim **15**, wherein said set of instructions for measuring a plurality of error values includes a set of instructions for detecting a contamination between a chemical indicator apparatus and an optical reader of the environment monitoring system, said a set of instructions for detecting a contamination including a set of instructions for using one or more measurement illuminations and one or more reference illuminations of the chemical indicator apparatus by the optical reader.

19. A machine-readable hardware storage medium according to claim **18**, wherein the contamination between the chemical indicator apparatus and the optical reader includes a contamination selected from the group consisting of a contaminant on a chemical indicator of the chemical indicator apparatus, a contaminant on a surface of the optical reader, a contaminant in water between the optical reader and the chemical indicator apparatus, a physical defect in a chemical indicator of the chemical indicator apparatus, and any combinations thereof.

20. A machine-readable hardware storage medium according to claim **15**, wherein said set of instructions for measuring a plurality of error values includes a set of instructions for referencing a stored expected value of a response from a chemical indicator with an actual detected value of a response from the chemical indicator; and a set of instructions for determining an error value from the relationship of the stored expected value and the actual detected value.

21. A machine-readable hardware storage medium according to claim **15**, wherein said set of instructions for measuring a plurality of error values includes:

a set of instructions for rotating a disc-shaped chemical indicator apparatus of the environment monitoring sys-

tem in a clockwise direction and taking one or more clockwise readings from the chemical indicator apparatus with an optical reader of the environment monitoring system;

a set of instructions for rotating the disc-shaped chemical indicator apparatus in a counter-clockwise direction and taking one or more counter-clockwise readings from the chemical indicator apparatus with the optical reader; and

a set of instructions for correlating the one or more clockwise readings with the one or more counter-clockwise readings to generate a friction error value.

22. A machine-readable hardware storage medium according to claim **15**, wherein said set of instructions for measuring a plurality of error values includes a set of instructions for determining an age of a chemical indicator of the environment monitoring system by referencing one or more stored values representing the amount of light illumination over time on the chemical indicator and/or referencing one or more stored values representing the amount of time the chemical indicator has been submersed in the water of the aquatic environment.

23. A machine-readable hardware storage medium according to claim **15**, wherein the correction instruction includes an instruction selected from the group consisting of an instruction to provide an alert to a user of the environment monitoring system to manually correct one or more error conditions, an instruction to the environment monitoring system to take an action to automatically correct one or more error conditions, an instruction to the environment monitoring system to stop automatically dosing one or more constituents to the aquatic environment, and any combinations thereof.

24. A machine-readable hardware storage medium according to claim **15**, wherein said set of instructions for determining a confidence level includes a set of instructions for combining information related to the degradation of the chemical indicator due to aging with information related to a condition selected from the group consisting of a physical contamination of a chemical indicator, an illumination imbalance related to an optical reader, a degradation of a light source of an optical reader, a physical contamination in water between an optical reader and a chemical indicator, a displacement due to friction between a chemical indicator apparatus and a monitoring unit, an error intrinsic in a chemical indicator, an error in distance between a chemical indicator apparatus and an optical reader, and any combinations thereof.

25. A method of monitoring errors in an aquatic environment monitoring system, the method comprising:

measuring one or more error values in the aquatic environment monitoring system using the environment monitoring system, each of the one or more error values being an error value related to a condition selected from the group consisting of a physical contamination of a chemical indicator, an illumination imbalance related to an optical reader, a degradation of a light source of an optical reader, a physical contamination in water between an optical reader and a chemical indicator, a displacement due to friction between a chemical indicator apparatus and a monitoring unit, an error intrinsic in a chemical indicator, an error in distance between a chemical indicator apparatus and an optical reader, and any combinations thereof;

determining a confidence level based on a combination of the one or more error values with information related to the age of a chemical indicator;

71

comparing the confidence level to a threshold value associated with the aquatic environment monitoring system; and

generating a correction instruction based on said comparing using a dosing calculator associated with the aquatic environment monitoring system, the correction instruction for correcting a condition associated with the one or more error values.

26. A method according to claim 25, wherein the one or more error values include an error value related to an illumination imbalance related to an optical reader.

27. A method according to claim 25, wherein the one or more error values include an error value related to a displacement due to friction between a chemical indicator apparatus and a monitoring unit.

28. A method according to claim 25, wherein the one or more error values include an error value related to an error in distance between a chemical indicator apparatus and an optical reader.

29. A method according to claim 25, wherein the one or more error values include an error value related to a degradation of a light source of an optical reader.

30. A method according to claim 25, wherein the aquatic environment monitoring system includes one or more chemical indicators on a chemical indicator holder and an optical reader configured for illuminating and reading the one or more chemical indicators.

31. A method according to claim 25, wherein said determining a confidence level includes using an error source action matrix.

32. A method according to claim 25, wherein said measuring one or more error values includes detecting a contamination between a chemical indicator apparatus and an optical reader of the environment monitoring system, said detecting a contamination including using one or more measurement illuminations and one or more reference illuminations of the chemical indicator apparatus by the optical reader.

33. A method according to claim 32, wherein the contamination between the chemical indicator apparatus and the optical reader includes a contamination selected from the group consisting of a contaminant on a chemical indicator of the chemical indicator apparatus, a contaminant on a surface of the optical reader, a contaminant in water between the

72

optical reader and the chemical indicator apparatus, a physical defect in a chemical indicator of the chemical indicator apparatus, and any combinations thereof.

34. A method according to claim 25, wherein said measuring one or more error values includes referencing a stored expected value of a response from a chemical indicator with an actual detected value of a response from the chemical indicator; and determining an error value from the relationship of the stored expected value and the actual detected value.

35. A method according to claim 25, wherein said measuring one or more error values includes:

rotating a disc-shaped chemical indicator apparatus of the environment monitoring system in a clockwise direction and taking one or more clockwise readings from the chemical indicator apparatus with an optical reader of the environment monitoring system;

rotating the disc-shaped chemical indicator apparatus in a counter-clockwise direction and taking one or more counter-clockwise readings from the chemical indicator apparatus with the optical reader; and

correlating the one or more clockwise readings with the one or more counter-clockwise readings to generate a friction error value.

36. A method according to claim 25, wherein said determining a confidence level includes determining an age of a chemical indicator of the environment monitoring system by referencing one or more stored values representing the amount of light illumination over time on the chemical indicator and/or referencing one or more stored values representing the amount of time the chemical indicator has been submersed in the water of the aquatic environment.

37. A method according to claim 25, wherein the correction instruction includes an instruction selected from the group consisting of an instruction to provide an alert to a user of the environment monitoring system to manually correct one or more error conditions, an instruction to the environment monitoring system to take an action to automatically correct one or more error conditions, an instruction to the environment monitoring system to stop automatically dosing one or more constituents to the aquatic environment, and any combinations thereof.

* * * * *