



US00D617958S

(12) **United States Design Patent**
Benincasa et al.

(10) **Patent No.:** **US D617,958 S**
(45) **Date of Patent:** **** Jun. 15, 2010**

(54) **WALL FOR BEEHIVE**

(76) Inventors: **Michael S. Benincasa**, 10352 Horseshoe Bend Rd., Sonora, CA (US) 95370;
David K. Buckman, 14820 Lakeside Dr., Sonora, CA (US) 95370

(**) Term: **14 Years**

(21) Appl. No.: **29/329,511**

(22) Filed: **Dec. 16, 2008**

(51) **LOC (9) Cl.** **30-02**

(52) **U.S. Cl.** **D30/108; D30/199**

(58) **Field of Classification Search** D30/199, D30/108-113, 117; 119/508, 500, 501, 498, 119/482, 161, 481, 483, 475, 484, 246, 165, 119/453, 452, 248, 269, 201, 502; 449/30, 449/1, 12, 2, 20, 25, 19, 27, 7, 28, 21, 8, 449/6, 23, 24, 26, 31, 13, 37, 60, 14, 11, 449/42-44; D9/304-316, 201, 273, 276, D9/283-286, 318, 319, 755, 781, 770; 312/263; 43/54.1, 55, 56; 217/54, 43 R; 294/158; 428/118, 116, 698; 220/560, 216, 4.28, 786, 220/847, 675, 676, 1.5, 6, 4.29, DIG. 12-DIG. 15, 220/DIG. 2; 206/503, 203, 512, 509; 156/78, 156/89.27, 89.22; 521/131; 427/255.11, 427/255.12, 255.19, 900; D7/550.1, 552.1, D7/553.1, 553.2, 553.7, 554.2-554.4, 561, D7/701; D6/525-540; D12/412, 414.1, D12/425; D19/75, 86, 90; 160/DIG. 7; 135/115, 119; 126/908

See application file for complete search history.

(56) **References Cited**

U.S. PATENT DOCUMENTS

200,549	A *	2/1878	Lawther	449/44
406,972	A *	7/1889	Tinker	449/8
874,579	A *	12/1907	Eckman	449/21
1,393,757	A *	10/1921	Crease	449/27
1,468,995	A *	9/1923	Cottam	449/25
1,482,468	A *	2/1924	Hershisher	449/28
1,556,254	A *	10/1925	Short	449/28

1,652,539	A *	12/1927	Marks	449/28
1,773,221	A *	8/1930	Davis	449/42
1,820,500	A *	8/1931	Sanders	449/42
1,889,184	A *	11/1932	Siemers	449/30
2,023,959	A *	12/1935	Knox	449/17
2,300,772	A *	11/1942	Borland	449/36
2,331,231	A *	10/1943	Root et al.	449/44
2,358,160	A *	9/1944	Haack	449/27
2,449,348	A *	9/1948	Volgenau et al.	449/25
2,474,382	A *	6/1949	Smith et al.	449/42
2,522,511	A *	9/1950	Hageman	449/10
2,599,141	A *	6/1952	Taylor	449/12
2,717,432	A *	9/1955	Willard	449/42
3,002,650	A *	10/1961	Lovell	206/509

(Continued)

Primary Examiner—Susan Moon Lee
(74) *Attorney, Agent, or Firm*—R. Michael West

(57) **CLAIM**

The ornamental design for a wall for beehive, as shown and described.

DESCRIPTION

FIG. 1 is a left front perspective of a wall for beehive, showing our new design;

FIG. 2 is a front elevational view, thereof;

FIG. 3 is a rear elevational view, thereof;

FIG. 4 is a top plan view, the bottom plan view being identical thereto;

FIG. 5 is an end elevational view, thereof, the opposite end elevational view being identical thereto; and,

FIG. 6 is a perspective view, thereof, the broken line representation of other wall pieces being shown solely for illustrative purposes.

The portions shown in broken line are not claimed.

1 Claim, 2 Drawing Sheets

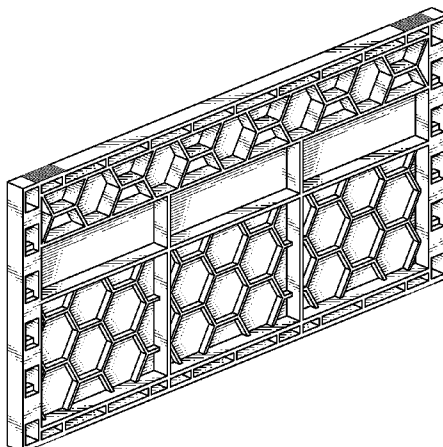

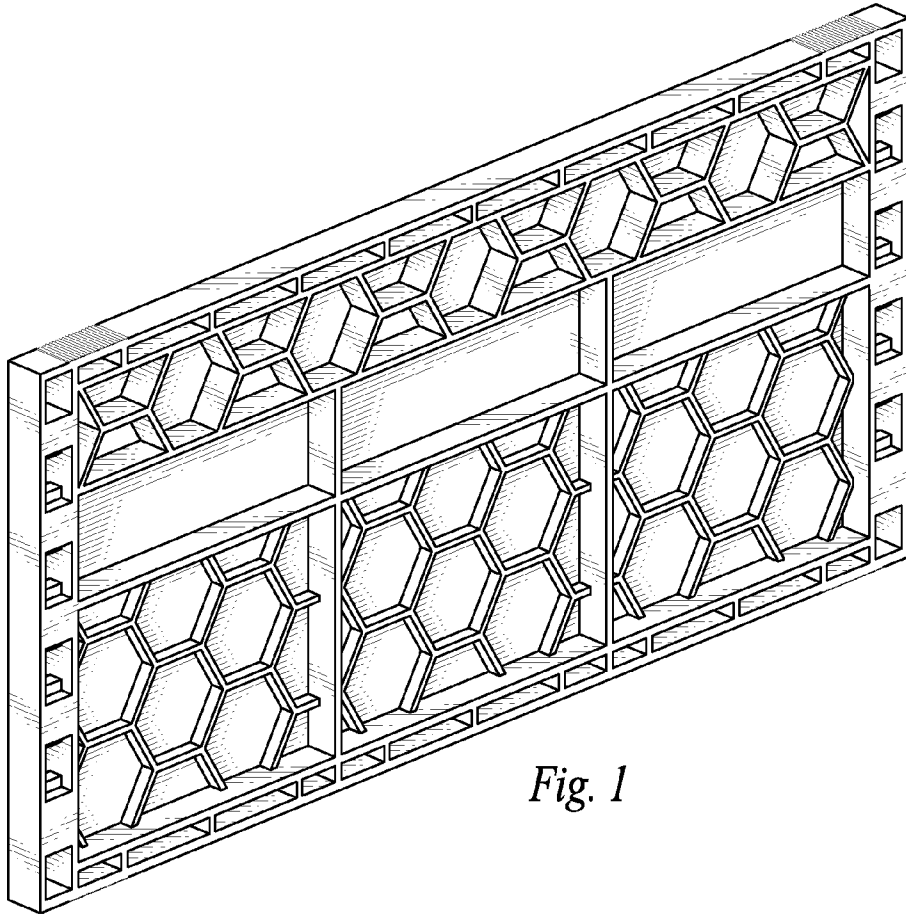

Fig. 1

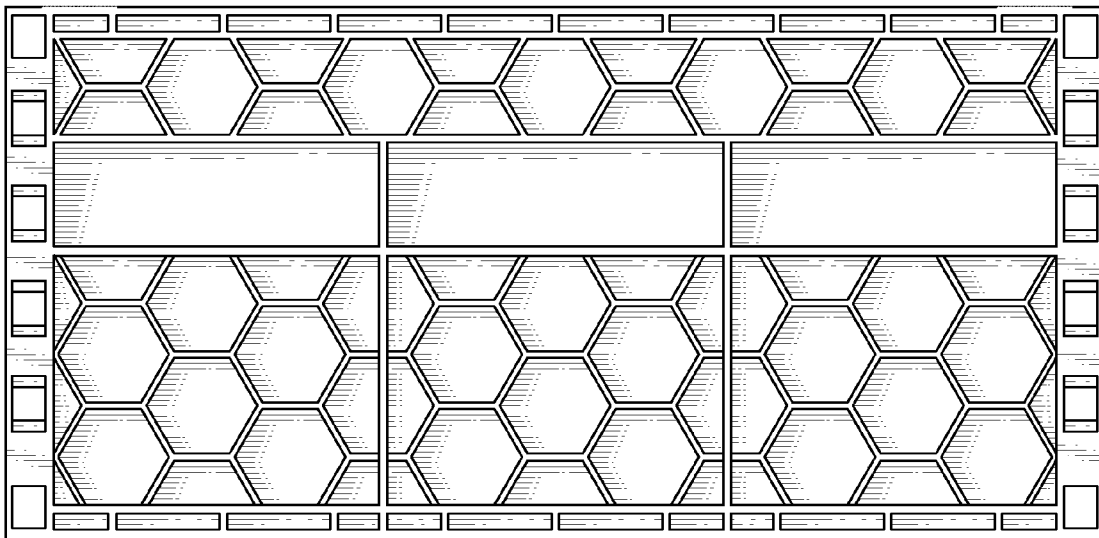

Fig. 2

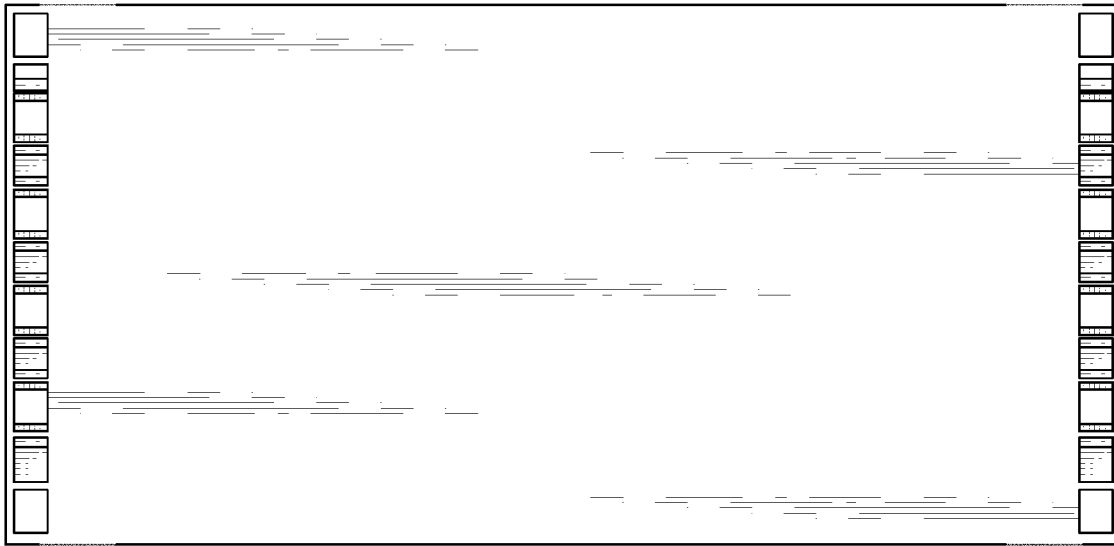

Fig. 3

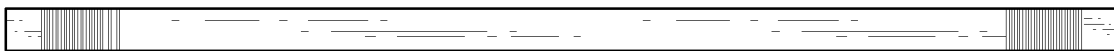

Fig. 4



Fig. 5

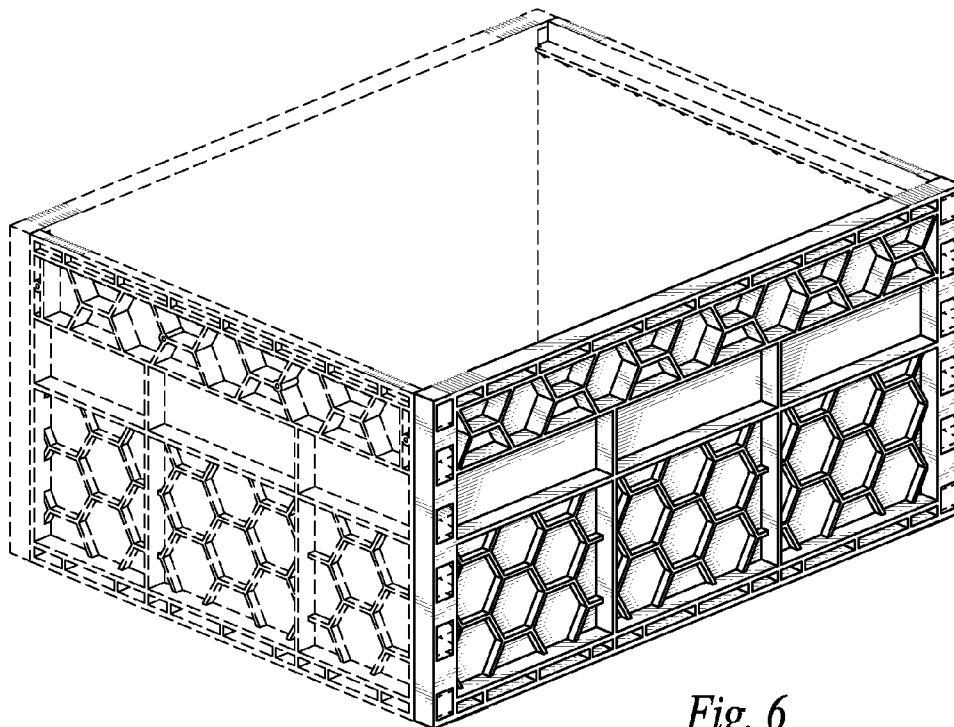

Fig. 6