



US00D719876S

(12) **United States Design Patent**  
**Tsutamori**

(10) **Patent No.:** **US D719,876 S**

(45) **Date of Patent:** **\*\* Dec. 23, 2014**

(54) **AUTOMOBILE AND/OR OTHER REPLICAS**

(71) Applicant: **Honda Motor Co., Ltd.**, Tokyo (JP)

(72) Inventor: **Daisuke Tsutamori**, Wako (JP)

(73) Assignee: **Honda Motor Co., Ltd.**, Tokyo (JP)

(\*\*) Term: **14 Years**

(21) Appl. No.: **29/470,943**

(22) Filed: **Oct. 25, 2013**

(30) **Foreign Application Priority Data**

Apr. 26, 2013 (JP) ..... 2013-009584

(51) **LOC (10) Cl.** ..... **12-08**

(52) **U.S. Cl.** ..... **D12/91**

(58) **Field of Classification Search**

CPC ..... B62D 35/00

USPC ..... D12/86, 90-92; D21/421, 433, 434;

296/181.1, 181.5

See application file for complete search history.

(56) **References Cited**

**U.S. PATENT DOCUMENTS**

D591,647 S \* 5/2009 Wang et al. .... D12/91

D605,557 S \* 12/2009 Murakami ..... D12/91

D605,558 S \* 12/2009 Koman et al. .... D12/91

D605,979 S \* 12/2009 Sahs ..... D12/91

D638,752 S \* 5/2011 Date et al. .... D12/91

D648,247 S \* 11/2011 Nemoto ..... D12/91

D691,515 S \* 10/2013 Tada et al. .... D12/91

D692,347 S \* 10/2013 Tada et al. .... D12/91

D695,150 S \* 12/2013 Tsutamori ..... D12/91

D696,156 S \* 12/2013 Campbell et al. .... D12/91

D696,607 S \* 12/2013 Campbell et al. .... D12/91

\* cited by examiner

*Primary Examiner* — Melody N Brown

(74) *Attorney, Agent, or Firm* — Westerman, Hattori, Daniels & Adrian, LLP

(57) **CLAIM**

The ornamental design for an automobile and/or other replicas, as shown and described.

**DESCRIPTION**

FIG. 1 is a front elevational view of the automobile and/or other replicas showing my new design;

FIG. 2 is a rear elevational view thereof;

FIG. 3 is a top plan view thereof;

FIG. 4 is a right side elevational view thereof;

FIG. 5 is a left side elevational view thereof;

FIG. 6 is a front perspective view thereof as seen from the right side; and,

FIG. 7 is a rear perspective view thereof as seen from the right side.

The broken lines illustrate environmental structure only and form no part of the claimed design.

**1 Claim, 4 Drawing Sheets**

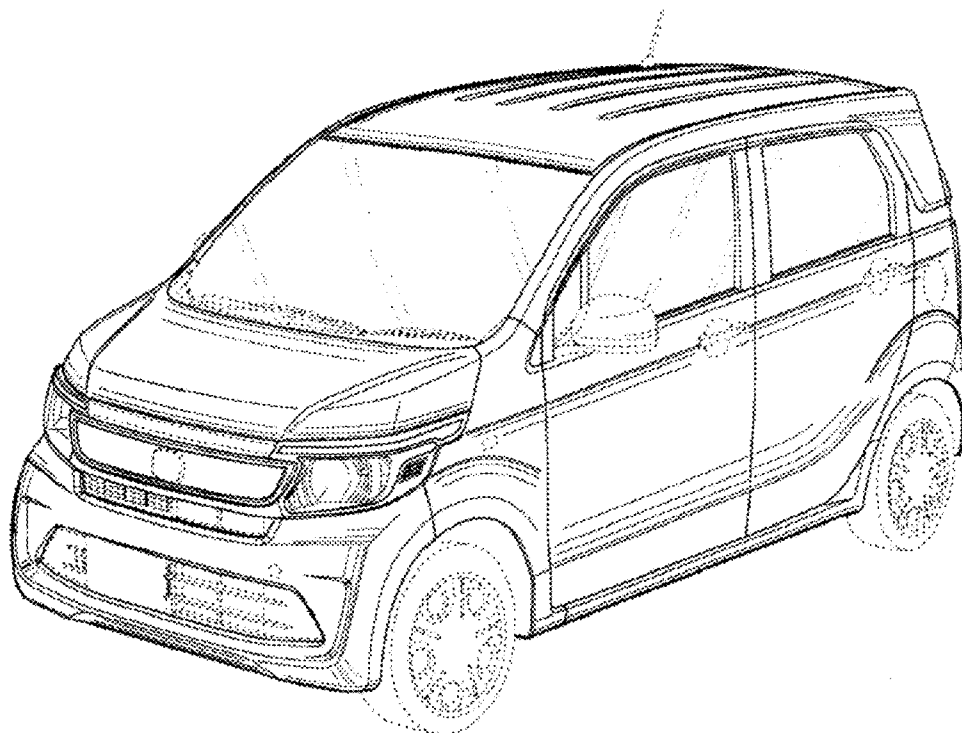

FIG.1

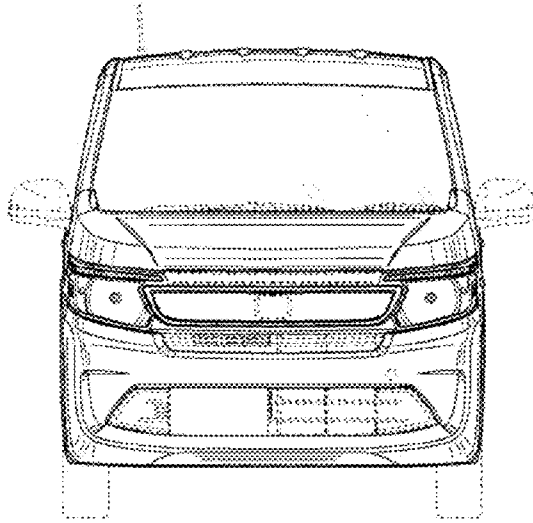

FIG.2

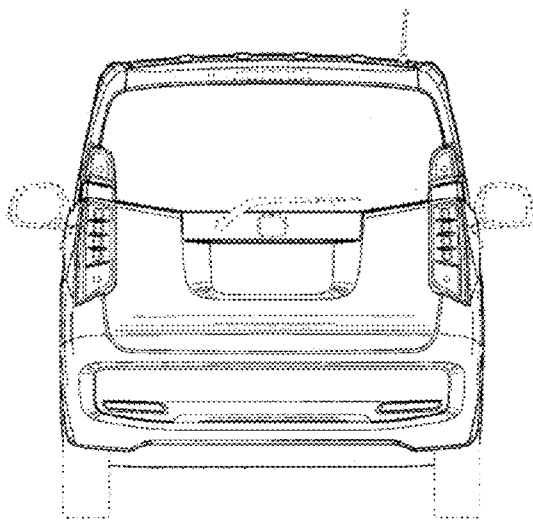

FIG.3

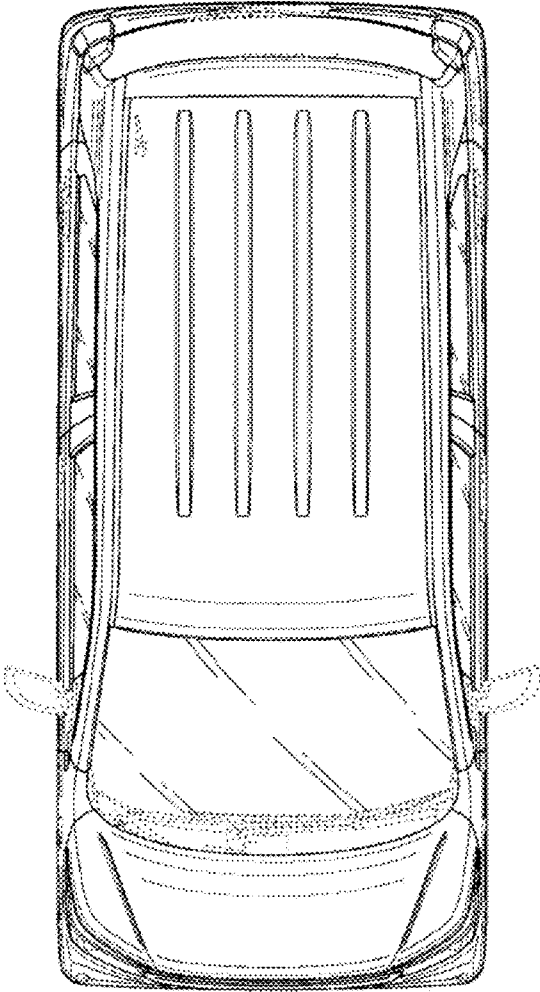

FIG.4

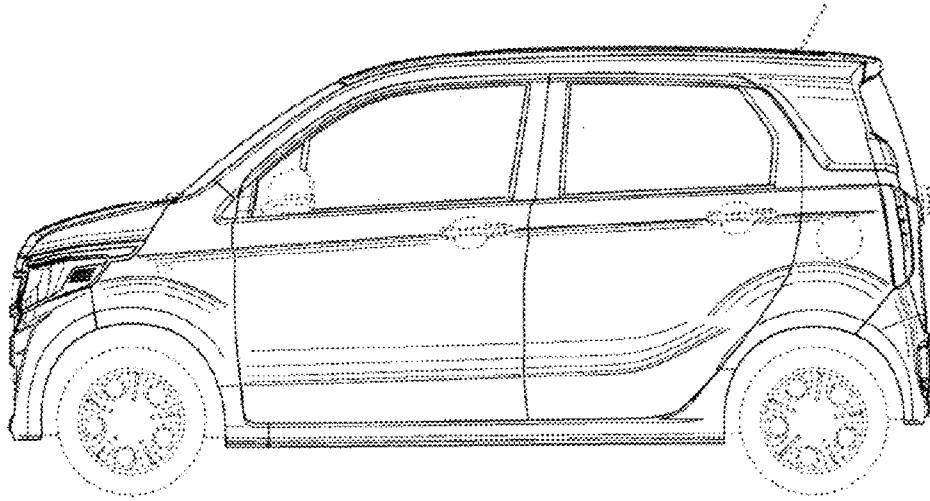

FIG.5

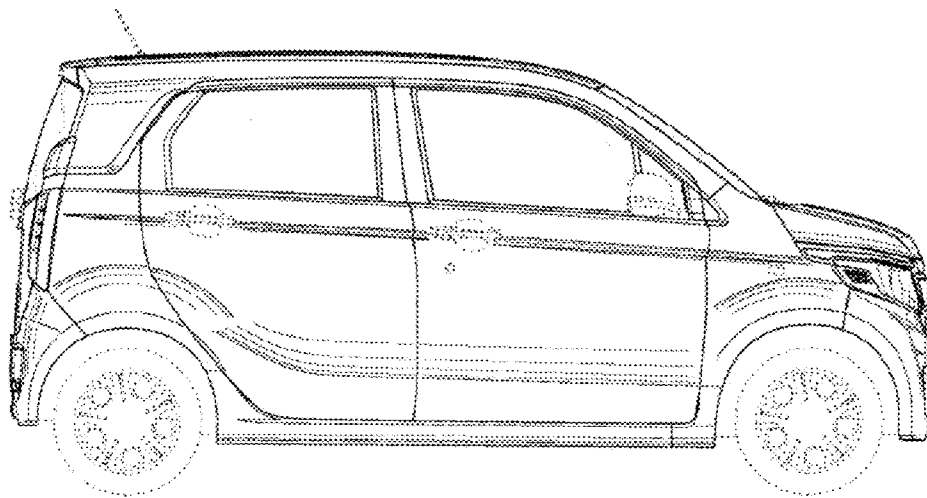

FIG.6

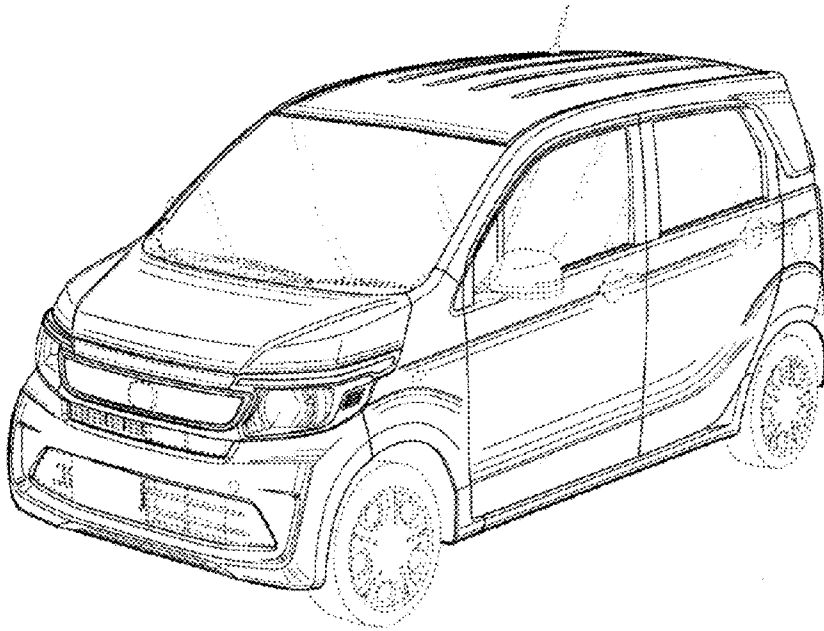

FIG.7

