

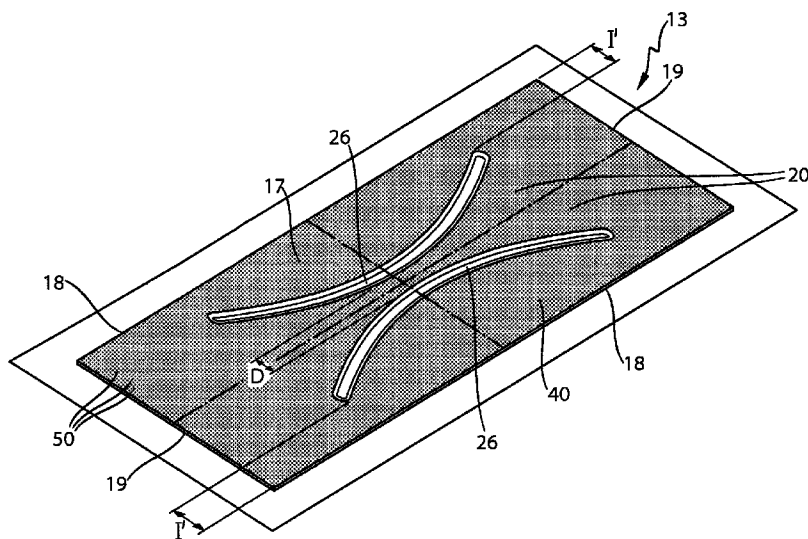

(22) Date de dépôt/Filing Date: 2013/11/12
(41) Mise à la disp. pub./Open to Public Insp.: 2014/05/22
(45) Date de délivrance/Issue Date: 2019/12/31
(62) Demande originale/Original Application: 2 890 759
(30) Priorités/Priorities: 2012/11/13 (US13/675,212);
2013/09/16 (US61/878,206)

(51) Cl.Int./Int.Cl. *A61F 13/84* (2006.01),
A61F 13/535 (2006.01), *A61F 13/536* (2006.01)
(72) Inventeurs/Inventors:
ROSATI, RODRIGO, DE;
KREUZER, CARSTEN HEINRICH, DE;
JACKELS, HANS ADOLF, DE;
ARIZTI, BIANCA, DE;
BIANCHI, ERNESTO, DE;
ROE, DONALD CARROLL, US;
...
(73) Propriétaire/Owner:
THE PROCTER & GAMBLE COMPANY, US
(74) Agent: WILSON LUE LLP

(54) Titre : ARTICLES ABSORBANTS AYANT DES CANAUX ET DES SIGNAUX
(54) Title: ABSORBENT ARTICLES WITH CHANNELS AND SIGNALS



(57) Abrégé/Abstract:

Absorbent articles herein may provide a topsheet, a backsheet, an absorbent core disposed between the topsheet and the backsheet, and a printed adhesive layer disposed between the topsheet and the absorbent core. The absorbent core may comprise channels, and the adhesive print layer may be visible through the topsheet.

(72) **Inventeurs(suite)/Inventors(continued)**: BROWN, DARRELL IAN, US; SANBORN, SARAH ANN, DE;
FITES, THEODORE CORY, DE

Abstract

Absorbent articles herein may provide a topsheet, a backsheet, an absorbent core disposed between the topsheet and the backsheet, and a printed adhesive layer disposed between the topsheet and the absorbent core. The absorbent core may comprise channels, and the adhesive print layer may be visible through the topsheet.

ABSORBENT ARTICLES WITH CHANNELS AND SIGNALS

FIELD OF THE INVENTION

The present invention relates to absorbent articles with channeled cores and printed signals.

5

BACKGROUND OF THE INVENTION

Absorbent articles for receiving and retaining bodily discharges such as urine or feces are well known in the art. Examples of these include disposable diaper(s), training pants and adult incontinence articles. Typically, disposable diapers comprise a liquid pervious topsheet that faces the wearer's body, a liquid impervious backsheet that faces the wearer's clothing and an absorbent core interposed between the liquid pervious topsheet and the backsheet.

An important component of disposable absorbent articles is the absorbent core/absorbent structure. The absorbent core/structure typically includes superabsorbent polymer material, such as hydrogel-forming polymer material, also referred to as absorbent gelling material, AGM, or super-absorbent polymer, SAP. This superabsorbent polymer material ensures that large amounts of bodily fluids, e.g. urine, can be absorbed by the absorbent article during its use and be locked away, thus providing low rewet and good skin dryness.

Traditionally, the superabsorbent polymer material is incorporated into the absorbent core structure with pulp, i.e. cellulose fibres. To make the absorbent core structures thinner, it has been proposed to reduce or eliminate these cellulose fibres from the absorbent core structures.

However, it was found that some absorbent core structures with reduced cellulose fibre levels, whilst very thin when not loaded with bodily fluids, may have an increased stiffness when partially loaded or fully loaded, especially in those regions which comprise most of the absorbent capacity of the absorbent article, such as the front region and crotch region of the diaper. It has been found that by providing specific permanent channels that are free of superabsorbent polymer particles or free of superabsorbent polymer material, improved liquid transport is achieved, and hence faster acquisition, and more efficient liquid absorbency over the whole absorbent structure; even though less absorbent material may be used, surprisingly improved performance can be achieved. By immobilising the absorbent material or channels (by the use of adhesive, the channels are more permanent, and remain channels during the use of the absorbent structure, e.g. when friction is applied to the absorbent structure, or when the absorbent structure is wetted, and the absorbent material expands. Furthermore, it has been found that by the provision of such channels, for example in the front region of the absorbent core/structure, and/or in the crotch region of the

absorbent core/structure, a diaper of increased flexibility can be provided, whilst surprisingly maintaining its performance throughout its use.

As the functionality of the absorbent core is changed to improve, e.g. absorbency, fit, or reduced cost, the performance and/or appearance of the article may be affected negatively. Efforts
5 can be made to modify the article or parts of the article in order to provide them with a particular appearance. In some examples, the article may be modified to communicate or signal to the caregiver that the channels exist in the absorbent core of the article, and that the channels are there to create faster and more efficient liquid absorbency. Such signalling or communication may be done, for example, via exterior graphics and/or interior printed adhesives. As such, there is a need
10 for improved absorbent articles comprising absorbent cores with channels that exhibit excellent performance and that are aesthetically pleasing.

SUMMARY OF THE INVENTION

Absorbent articles herein may provide a topsheet, a backsheet, an absorbent core disposed
15 between the topsheet and the backsheet, and a printed adhesive layer disposed between the topsheet and the absorbent core. The absorbent core may comprise channels, and the adhesive print layer may be visible through the topsheet.

BRIEF DESCRIPTION OF THE DRAWINGS

20 Figure 1 shows a plan view of a diaper in accordance with one non-limiting embodiment.

Figure 2A shows a perspective view of an absorbent structure in accordance with one non-limiting embodiment.

Figure 2B shows a perspective view of an alternative absorbent layer in accordance with one non-limiting embodiment.

25 Figure 2C shows a perspective view of an absorbent structure that may be combined with the absorbent structure in accordance with one non-limiting embodiment.

Figure 3A shows a perspective view of an alternative absorbent layer in accordance with one non-limiting embodiment.

30 Figure 3B shows a perspective view of an alternative absorbent structure in accordance with one non-limiting embodiment.

Figure 4A shows a perspective view of an alternative absorbent layer in accordance with one non-limiting embodiment.

Figure 4B shows a perspective view of an alternative absorbent layer in accordance with one non-limiting embodiment.

Figure 5 shows a cross sectional view of an absorbent core in accordance with one non-limiting embodiment.

5 Figure 6 shows a cross sectional view of an alternative absorbent core in accordance with one non-limiting embodiment.

Figure 7 shows a cross sectional view of an alternative absorbent core in accordance with one non-limiting embodiment.

10 Figure 8 shows a cross sectional view of an alternative absorbent core in accordance with one non-limiting embodiment.

Figure 9 shows a cross sectional view of an alternative absorbent core in accordance with one non-limiting embodiment.

Figure 10 shows a cross sectional view of an alternative absorbent core in accordance with one non-limiting embodiment.

15 Figure 11 shows a cross sectional view of an alternative absorbent core in accordance with one non-limiting embodiment.

Figure 12 shows a cross sectional view of an alternative absorbent core in accordance with one non-limiting embodiment.

20 Figure 13 shows a cross sectional view of an alternative absorbent core in accordance with one non-limiting embodiment.

Figure 14 shows a method/ apparatus of forming an absorbent core in accordance with one non-limiting embodiment comprising two absorbent structures of the disclosure.

Figure 15 and 16 show plan views of non-limiting embodiments of an absorbent article of the present invention comprising backsheet graphics.

25 Figures 17A, 17B, 17C, and 18 show top view representations of non-limiting embodiments of printed adhesive patterns.

Fig. 19 shows a plan view of backsheet graphics that approximate the shape and contours of the channels.

30 DETAILED DESCRIPTION OF THE INVENTION

Definitions

"Absorbent article" refers to a device that absorbs and contains body exudates, and, more specifically, refers to devices that are placed against or in proximity to the body of the wearer to

absorb and contain the various exudates discharged from the body. Absorbent articles may include adult and infant diaper (1), including pants, such as infant training pants and adult incontinence undergarments, and feminine hygiene products, such as sanitary napkins and panty-liners and adult in continent pads, and breast pads, care mats, bibs, wound dressing products, and the like.

5 Absorbent articles may further include floor cleaning articles, food industry articles, and the like. As used herein, the term "body fluids" or "body exudates" includes, but is not limited to, urine, blood, vaginal discharges, breast milk, sweat and fecal matter.

As used herein "diaper (1)" refers to devices which are intended to be placed against the skin of a wearer to absorb and contain the various exudates discharged from the body. Diaper (1)s are generally worn by infants and incontinent persons about the lower torso so as to encircle the waist and legs of the wearer. Examples of diaper (1)s include infant or adult diaper (1)s and pant-like diaper (1)s such as training pants. A diaper may comprise a fastening system, which may include at least one fastening member (8) and at least one landing zone (9), and may also comprise leg cuffs (10) and elastic members (11). "Training pant", as used herein, refers to disposable garments having a waist opening and leg openings designed for infant or adult wearers. A pant may be placed in position on the wearer by inserting the wearer's legs into the leg openings and sliding the pant into position about a wearer's lower torso. A pant may be preformed by any suitable technique including, but not limited to, joining together portions of the article using refastenable and/or non-refastenable bonds (e.g., seam, weld, adhesive, cohesive bond, fastener, etc.). A pant may be preformed anywhere along the circumference of the article (e.g., side fastened, front waist fastened).

"Disposable" is used herein to describe articles that are generally not intended to be laundered or otherwise restored or reused (i.e., they are intended to be discarded after a single use and, may be recycled, composted or otherwise disposed of in an environmentally compatible manner).

As used herein "absorbent structure (13)" refers to a three dimensional structure useful to absorb and contain liquids, such as urine. The absorbent structure (13) may be the absorbent structure (13) of an absorbent article or may be only part of the absorbent core (7) of an absorbent article, i.e. an absorbent component of the absorbent core (7), as will be further described herein.

30 "Superabsorbent polymer material" as used herein refers to substantially water-insoluble polymer material that can absorb at least 10 times (and typically at least 15 times or at least 20 times) its weight of a 0.9% saline solution in de-mineralized water as measured using the Centrifuge Retention Capacity test (Edana 441.2-01).

“Nonwoven material” as used herein refers to a manufactured web of directionally or randomly orientated fibers, excluding paper and products which are woven, knitted, tufted, stitch-bonded incorporating binding yarns or filaments, or felted by wet-milling, whether or not additionally needled. Nonwoven materials and processes for making them are known in the art.

5 Generally, processes for making nonwoven materials comprise laying fibers onto a forming surface, which may comprise spunlaying, meltblowing, carding, airlaying, wetlaying, coform and combinations thereof. The fibers may be of natural or man-made origin and may be staple fibers or continuous filaments or be formed in situ.

“Visible” as used herein means capable of being perceived by the unaided human eye.

10

Absorbent structure (13) with channels

The present invention provides absorbent articles with absorbent cores comprising channels and printed signals that communicate the channels. The present invention relates to absorbent articles with channels disclosed in US publications 2012-0316526, 2012-0316527, 2012-0316528, and 2012-0316529, all filed June 10, 2011.

15

The absorbent structure (13) herein comprises a supporting sheet (16) with an absorbent layer (17) of absorbent material (50). The absorbent material (50) comprises at least a superabsorbent polymer material and optionally a cellulosic material, such as a cellulose, e.g. pulp, or modified cellulose.

20

The absorbent structure (13) also comprises one or more adhesive material(s), further described below. The absorbent layer (17) is three dimensional and comprises a first substantially longitudinal channel (26) and a second substantially longitudinal channel (26) that are substantially free of said superabsorbent polymer material. Other materials may be present in said channels (26), as further described below, for example said one or more adhesive material(s) (40; 60).

25

The absorbent structure (13) and the absorbent layer (17) each have a longitudinal dimension and average length L, e.g. extending in the longitudinal dimension of the structure or layer and a transverse dimension and average width W, e.g. extending in the transverse dimension of the structure or layer. The absorbent structure (13) and the absorbent layer (17) each have a front region, being in use towards the front of the user, back region, being in use towards the back of the user, and therein between a crotch region, each extending the full transverse width of the structure/layer, and each having 1/3 of the average length of the structure/layer.

30

The absorbent structure (13) and the absorbent layer (17) each possess a central longitudinal axis X, a central transverse axis Y perpendicular to said central longitudinal axis X; said absorbent

layer (17) and said absorbent structure (13) have each a pair of opposing longitudinal side edges extending in the longitudinal dimension of the structure or layer and a pair of opposing transverse edges (19), e.g. front transverse edge being in use towards the front of a user (wearer), and a back transverse edge being in use towards the back of a user. The longitudinal side edges (18) and/or transverse edges (19) of the absorbent structure (13) or absorbent layer (17) may be parallel respectively to the central longitudinal axis and/or central transverse axis respectively or one or more may be curvilinear, and for instance provide for a narrower transverse dimension in the crotch region. Typically the longitudinal side edges are mirror images of one another in the longitudinal X-axis.

10 The central longitudinal X-axis of the absorbent layer (17) delimits first and second longitudinal side portions (20) of the absorbent layer (17), respectively, referred herein as longitudinal side portions (20). Each of said longitudinal side portions is thus present in said front region, crotch region and back region, and hence, there is a first longitudinal portion's front region, and a second longitudinal portion's front region etc. In some embodiments herein, said longitudinal portions of the absorbent layer (17) are mirror images of one another in the X-axis of the layer.

15 The absorbent layer (17) comprises at least a first channel (26) and second channel (26) that are substantially free of (e.g. free of) said superabsorbent polymer particles, said channels (26) extending through the thickness (height) of the absorbent layer (17). (It should be understood that, accidentally, a small, negligible amount of superabsorbent polymer particles may be present in the channel, which does not contribute to the overall functionality). When the absorbent layer (17) comprises cellulosic or cellulose, in some embodiments the said first and second channels (26) are also free of such cellulosic / cellulose material.

20 The first channel (26) is present in said first longitudinal side portion of the absorbent layer (17) and the second channel (26) is present in said second longitudinal side portion of the absorbent layer (17).

25 The first and second channel (26) each extend substantially longitudinally, which means typically that each channel (26) extends more in the longitudinal dimension than in the transverse dimension, and typically at least twice as much in the longitudinal dimension than in the transverse dimension.

30 Thus, this includes channels (26) that are completely longitudinal and parallel to the longitudinal direction of said absorbent layer (17) (i.e. paralleled to said longitudinal-axis); and this includes channels (26) that may be curved, provided the radius of curvature is typically at least equal (optionally at least 1.5 or at least 2.0 times this average transverse dimension) to the average

transverse dimension of the absorbent layer; and this includes channels (26) that are straight but under an angle of (e.g. from 5°) up to 30°, or for example up to 20°, or up to 10° with a line parallel to the longitudinal axis. This may also include channels with an angle therein, provided said angle between two parts of a channel is at least 120°, at least 150°; and in any of these cases, provided
5 the longitudinal extension of the channel is more than the transverse extension.

In some embodiments, there may be no completely or substantially transverse channels present in at least said crotch region, or no such channels at all.

Each of said first and second channels (26) may have an average width W' that is least 4% of the average width W of said absorbent layer (17), or for example W' is at least 7% of W ; and/
10 or for example and up to 25% of W , or up to 15% of W ; and/ or for example at least 5 mm; and for example up to 25 mm, or for example up to 15 mm.

Each of said first and second channels (26) may have an average length L' which may for example be up to 80% of the average length L of said absorbent layer (17); if the channels (26) are only in the front region, or only in the crotch region, or only in the back region, L' is for example
15 up to 25% of L , or up to 20% of L , and/ or L' is for example at least 5% of L , or at least 10% of L ; and/ or L' is for example at least 10 mm, or at least 20 mm; if the channels (26) extend in said crotch region and front region, and optionally the back region, L' is for example up to 80% of L , or up to 70% of L , and/ or L' is for example at least 40% of L , or at least 50% of L . In case the channel is not parallel to the longitudinal axis, the length L' of the channel is the length as measured
20 by projection against the longitudinal axis.

The channels (26) may typically be so-called "permanent" channels (26). By permanent, it is meant that the integrity of the channels (26) is at least partially maintained both in the dry state and in the wet state, including during friction by the wearer thereon. The Wet Channel Integrity Test described below can be used to test if channels are permanent following wet saturation and to
25 what extent.

Permanent channels (26) may be obtained by provision of one or more adhesive material that immobilize said absorbent material (50), and/ or said channels (26), e.g. or said absorbent layer (17), and/ or that immobilize said supporting sheet (16) into said channels (26), or part thereof. The absorbent cores (7) may comprise in particular permanent channels formed by bonding of the first
30 supporting sheet (16) and second supporting sheet (16') through the channels, as exemplarily shown in Fig. 7 and Fig. 13 for example. Typically, glue may be used to bond both supporting sheets through the channel, but it is possible to bond via other known means, for example

ultrasonic bonding, or heat bonding. The supporting layers can be continuously bonded or intermittently bonded along the channels.

Indeed, the inventors observed that such channels provide for fast liquid acquisition which reduces risk of leakages. The permanent channels help to avoid saturation of the absorbent layer in the region of fluid discharge (such saturation increases the risk of leakages). Furthermore, the inventors surprisingly found that, in contrast to what would be expected, whilst decreasing the overall amount of superabsorbent polymer material in the absorbent structure is reduced (by providing channels free of such material), the fluid handling properties of the absorbent structure, or diaper, are improved. Permanent channels, also have the further advantages that in wet state the absorbent material cannot move within the core and remains in its intended position, thus providing better fit and fluid absorption.

For example, the inventors have compared the amount of AGM loss in a wet state according to the WAITT test for a core having two absorbent layers with permanent channels as shown in Fig. 4A relative to a similar core with same amount of AGM and glue but having no channels .

In short, the WAITT test determines the amount of non-immobilized absorbent particulate material amount in the cores in wet conditions. In this test, the absorbent core is wet to 73% capacity and is cut in its middle in the transversal direction and left to fall from a pre-determined height and loss of material is measured. Further information regarding the test can be found in US 2008/0312622 A1.

The results were that the core had a Wet Immobilization of 87 % (StDev = 5%) of AGM compared to a Wet Immobilization of 65% (StDev = 5%) for the comparative core without channels. In this example the channels were made permanent by adhesive bonding of the two supporting sheets in the channels using two layers of thermoplastic fibrous adhesive (Fuller 1151 applied twice at 5 gsm) and one layer of hotmelt adhesive (Fuller 1358 applied at 5 gsm).

Wet Channel Integrity Test

This test is designed to check the integrity of a channel following wet saturation. The test can be performed directly on an absorbent structure or on an absorbent core containing the absorbent structure.

1. The length (in millimeters) of the channel is measured in the dry state (if the channel is not straight, the curvilinear length through the middle of the channel is measured).

2. The absorbent structure or core is then immersed in 5 liters of synthetic urine “Saline”, with a concentration of 9.00 g NaCl per 1000 ml solution prepared by dissolving the appropriate amount of sodium chloride in distilled water. The temperature of the solution must be 20 +/- 5 °C.

5 3. After 1 minute in the saline, the absorbent structure or core is removed and held vertically by one end for 5 seconds to drain, then extended flat on a horizontal surface with the garment-facing side down, if this side is recognizable. If the absorbent structure or core comprises stretch elements, the absorbent structure or core is pulled taut in both X and Y dimensions so that no contraction is observed. The extremes/edges of the absorbent
10 structure or core are fixed to the horizontal surface, so that no contraction can happen.

4. The absorbent structure or core is covered with a suitably weighted rigid plate, with dimensions as follows: length equal to the extended length of the absorbent structure or core, and width equal to the maximum absorbent structure or core width in the cross direction.

15 5. A pressure of 18.0 kPa is applied for 30 seconds over the area of the rigid plate above mentioned. Pressure is calculated on the basis of overall area encompassed by the rigid plate. Pressure is achieved by placing additional weights in the geometric center of the rigid plate, such that the combined weight of the rigid plate and the additional weights result in a pressure of 18.0 kPa over the total area of the rigid plate.

20 6. After 30 seconds, the additional weights and the rigid plate are removed.

7. Immediately afterwards, the cumulative length of the portions of the channel which remained intact is measured in millimeters; (if the channel is not straight, the curvilinear length through the middle of the channel is measured). If no portions of the channel remained intact then the channel is not permanent.

25 8. The percentage of integrity of the permanent channel is calculated by dividing the cumulative length of the portions of the channel which remained intact by the length of the channel in the dry state, and then multiplying the quotient by 100.

Advantageously, a permanent channel according to the disclosure has a percentage of integrity of at least 20%, or 30%, or 40%, or 50%, or 60, or 70%, or 80%, or 90% following this
30 test.

As for example shown in Figures 5 and 9, one or more adhesive material(s) (60) may be present between said supporting sheet (16) and said absorbent layer (17), or parts thereof (e.g. herein referred to as, “second adhesive material”). For example, an adhesive material is applied to

portions of said supporting sheet (16) that are to coincide with the channels (26), so that in said channels the supporting sheet can be bonded with said adhesive to the walls of the channel, or part thereof or to a further material, as described herein; and/ or the adhesive may be applied to portions of the supporting sheet (16) that are to coincide with the absorbent material (50), to immobilize said material and avoid extensive migration thereof into said channels; the adhesive may be applied over substantially the whole surface area of the supporting sheet (16), e.g. substantially continuously and/ or homogeneously. This may for example be a hotmelt adhesive applied by printing, slot coating or spraying.

In addition, or alternatively, the absorbent structure (13) may comprise one or more adhesive materials (40) applied on said absorbent layer (17) or part thereof, that is already supported by said supporting sheet (16), (herein referred to as "first adhesive material") e.g. after said absorbent material (50) is combined with/ deposited on said supporting sheet (16) to form an absorbent layer (17). This may for example be a thermoplastic fibrous adhesive, as described herein after. In some embodiments, this may be applied continuously over the absorbent layer (17), hence over the absorbent material (50) and in the channels (26), to immobilize the absorbent layer and to optionally also adhere the supporting sheet in said channel, as described above. This is for example shown in Figures 5 to 11.

It should be understood that the first and second adhesive material may be the same type of adhesive, for example as a thermoplastic hotmelt adhesive, for example as described below, the difference between the first and second adhesive thus being the location where it is applied.

In some embodiments, said one or more adhesive material are at least present in the channels (26), for example at least said first adhesive material, or both said first and second adhesive material. It may thus be present on the longitudinal walls of the channels (26) (extending the height of the absorbent layer (17) and the length thereof). If the supporting sheet (16) material folds into said channels (26), or part thereof, e.g. the supporting sheet (16) has undulations into said channels (26) or part thereof, said undulations may be fixed to said walls or part thereof, to ensure the channels (26) are maintained (at least partially) during use. This is for example shown in Figures 10 and 11

The first and second channels (26) may be mirror images of one another with respect to the central longitudinal axis (X-axis) of the absorbent layer (17)/ structure.

In some embodiments, and as for example shown in the Figures, there is no channel (26) that coincides with said longitudinal axis of said absorbent layer (17). The channels (26) may be spaced apart from one another over their whole longitudinal dimension. The smallest spacing

distance D may for example be at least 5% of average transverse dimension W of layer , or for example at least 10% of W , or at least 15% of W ; or for example may be at least 5 mm, or for example at least 8 mm.

Furthermore, in order to reduce the risk of fluid leakages, the longitudinal main channels
5 (26) typically do not extend up to any of the transverse edges (19) and/or longitudinal edges (18) of the absorbent layer (17), as for example shown in the Figures. Typically, the smallest distance I between a channel (26) and the nearest longitudinal edge corresponds to at least 5% of W , or for example to at least 10% of W . In some embodiments, the distance is for example at least 10 mm; the smallest distance F between a channel and the nearest transverse edge (19) of the absorbent
10 layer (17) may for example be at least 5% of the average length L of the layer.

The absorbent structure may comprise only two channels, for example only in the front region, such as for example shown in Figures 2B, or for example in the central (crotch) region, and optionally extending into the front and/or back region, such as shown Figure 2A.

The absorbent structure (13) may comprise more than two of such channels (26), for
15 example at least 4, or at least 5 or at least 6. Some or all of these may be substantially parallel to one another, for example being all straight and completely longitudinally, and/ or two or more or all may be mirror images of one another in the longitudinal axis, or two or more may be curved (e.g. non-linear) or angled and for example mirror images of one another in the longitudinal axis, and two or more may be differently curved or straight, and for example mirror images of one
20 another in the longitudinal axis.. This is for example shown in Figure 3 A and 3B.

For example the front region of the absorbent layer (17) may comprise two or more channels (26), that are typically mirror images of one another in the longitudinal axis of the layer, and the crotch region may comprise two or more channels (26), that are typically mirror images of one another in the longitudinal axis of the layer, for example shown in Figure 4A, and the latter
25 may optionally extend into the front region and/ or back region, with any of applicable dimensions and other characteristics described above. Optionally, further channel(s) may be present in the back region, for example two, such as for example shown in Figure 4B.

The first and second channels (26), and optionally further channels (26), may be positioned in said absorbent layer (17) such that there is a central longitudinal strip, coinciding with said
30 longitudinal axis, which is free of any channels (26); said absorbent material (50) may be substantially continuously present in said strip. For example, said strip may have a minimum width D of at least 5% of W , or at least 10% of W , and/ or for example at least 5 mm, or at least 10 mm or at least 15 mm, and/ or even up to 40 mm.

In some embodiments, in said central longitudinal strip between two neighboring channels (26) the average basis weight of absorbent material (50), or of said superabsorbent polymer material, is at least 350, and for example up to 1000 grams per m², or for example from 450 grams per m², and for example up to 750 grams per m².

5 In some embodiments, adjacent each first and second channel, and optionally adjacent said further channel(s), said absorbent material (50) is substantially continuously present.

The absorbent structure (13) typically comprises one or more further material(s) (e.g. a further material layer) to cover the absorbent layer (17), herein referred to as further material; the further material may be a layer comprising adhesive, for example on the surface that is to contact
10 the absorbent layer (17) of the absorbent structure (13) herein. Thus, the further material may comprise, on the surface to be placed adjacent said absorbent layer (17) of the absorbent structure (13), an adhesive material.

The resulting structure is herein referred to as “absorbent core (7)”. Examples thereof are shown in Figures 5 to 13.

15 This further material may be a further absorbent structure (13'), with a second absorbent layer (17') and a second supporting sheet (16'), so that both absorbent layers (17, 17') are sandwiched between said supporting sheets (16; 16'); this may be a further absorbent structure (13') of the disclosure, with two or more channels (26') as described herein, and for example shown in Figures 5, 6, 7, 8; or this may be a absorbent structure as described herein but without channels,
20 such as for example shown in Figure 9; and/ or it may be an absorbent structure as described herein but without adhesive.

The second absorbent structure (13') may be identical to the first absorbent structure (13), or they may both be absorbent structure with channels (26; 26') of the disclosure, but they may be different, for example having different channels, different number of channels (such as for example
25 shown in Figure 8), different adhesive, different adhesive application or combinations thereof.

The channels (26), or some of those, of the first absorbent structure (13) and the channels (26') of the second absorbent structure (13'), or some of those, may coincide and overlap with one another; e.g. completely or for example coincide only partially and overlap only partially; or some or all of the channels (26; 26') may even not coincide and not overlap one another. In some
30 embodiments they are about identical to one another and the channels (26) of one structure substantially completely coincide and overlap the channels (26) of another structure. This is for example shown in Figure 12.

In some embodiments, the further material may be a part of the supporting sheet (16), which is folded over the absorbent layer (17) and then sealed along the peripheral edges, to enclose the absorbent layer (17).

5 In some embodiments, the further material is a further supporting sheet (16'), i.e. the absorbent structure (13) is covered with a further supporting sheet (16'), said absorbent layer then being sandwiched between the two supporting sheets.

In some embodiments, the further material may be an acquisition material layer (70) and/or an acquisition sheet (12), for example sealed to said supporting sheet (16). In some embodiments, the further material includes a further absorbent structure, e.g. any of those described
10 above, or further supporting sheet (16'), and then combined with an acquisition material layer (70), and optionally a further acquisition sheet (12). This is for example shown in Figure 11.

The further material may also be an acquisition material layer (70) present adjacent said absorbent layer (17), the acquisition material layer (70) optionally comprising chemically cross-linked cellulosic fibers, and the acquisition material layer being supported on a second supporting
15 sheet (16'). The absorbent layer (17) and the acquisition material layer (70) may then be sandwiched between said supporting sheet (16) of the first structure and said second supporting sheet (16'), as exemplary shown in Fig. 12. The acquisition material layer (70) may also further comprise channels (26'), in particular substantially completely overlapping with the channels (26) of said first absorbent structure (13) as shown in Fig. 13.

20 The supporting sheet (16) of the first structure and/or the second supporting sheet (16') of the acquisition material layer (70) may fold into the channels (26) of the first absorbent structure (13) and/or optionally into the channels (26') of the acquisition material layer (70), if present, or part of these channels (26, 26'). The one or more adhesive material(s) may be at least present in the channels (26, 26'), or part thereof, and the supporting sheets (16; 16') may be adhered to one
25 another in said channels (26, 26') by one or more of these adhesive material(s). Another second adhesive (60') may be present between the second supporting sheet (16') and the acquisition material layer (70). Another adhesive (not represented) may be placed between the acquisition material layer (70) and the absorbent layer (17), in addition to the thermoplastic adhesive (40), to improve better adhesion of both layers.

30 In any of these cases, the further material, can then be sealed to the supporting sheet (16) along the peripheral edges thereof, to enclose the absorbent layer (s) (17; optionally 17').

In any of these cases the supporting sheet (16) or acquisition layer/ sheet may fold into (i.e. undulate into) said channels (26) or part thereof. This is shown for example in Figures 6, 7, 8.

It may be adhered to the supporting sheet (16) of the absorbent structure (13) of the disclosure in said channels (26), e.g. by an adhesive material, as described herein. Alternatively, or in addition, it may be adhered to the walls of the channels (26 and/or 26') or part thereof.

5 In some embodiments the absorbent structure (13) comprises such a further material overlaying said absorbent layer (17), and a pressure means is applied selectively to said supporting sheet (16) and/ or to said further material, in those parts that coincide with said channels (26 and/or 26'), to pressurize said supporting sheet (16) and/ or said further material into said channels of the absorbent structure (13) and/or into the channels of a further (second) absorbent structure (13') if present (so: into channels 26 and/or 26', if present), to aid formulation of said undulations and/ or to aid adhering of the further material and said supporting sheet (16) to one another in said channels
10 (26 and/or 26'), if an adhesive material is present as described herein.

The pressure means may be a pressure roll with raised portions that have substantially the size, shape, pattern of said channels (26 and/or 26'), that can coincide (i.e.: mate) with said parts of the supporting sheet (16) or further material coinciding with said channels (26 and/or 26').

15 In some embodiments, the further (e.g. second) supporting sheet (16') may be wider than the absorbent structure to enable the second supporting sheet (16') to fold into the channels (26 and/or 26') or part thereof, and thereby may adhere to the first supporting sheet (16). This is for example shown in Figures 6, 7 and 8.

In embodiments wherein the absorbent core (7) comprises two (or more) absorbent
20 structures (13; 13') comprising the channels (26; 26'), described herein, it may be that one or two, or more, or all, of the channels (26) of one absorbent structure (13) substantially superpose the channels (26') of the adjacent absorbent structure (13'). The resulting absorbent core (7) is then a laminate of absorbent structures (13; 13') with channels (26; 26'), wherein the channels (26; 26') extend substantially through the thickness of the absorbent layers (17; 17'). This is for example
25 shown in Figure 12.

In addition or alternatively, it may be that one or two, or more, or all, channels (26) of one absorbent structure (13) do not superpose the channels (26') of the adjacent absorbent structure (13'); they may for example be complementary with the channels (26) of the adjacent structure. By complementary it is meant that the channels (26') of the second absorbent structure (13') form
30 an extension of the channels (26) of the first absorbent structure (13).

In some embodiments, the absorbent core (7) may comprise two or more absorbent structures (13), one of which being the structure of the disclosure, and one being an absorbent

structure (13) with a supporting sheet (16') with thereon an absorbent layer (17') (with superabsorbent polymer material) without channels and/or without adhesive.

If a second absorbent structure (13') is present in the absorbent core (7), this may comprise one or more adhesives, in the manner as described above, and for the reasons described above.

5 For example, it may be present such that it coincides with the channels (26) of the first absorbent structure (13) at least, and/ or with its channels (26'), if present.

Absorbent material (50)

10 The absorbent layer (17) comprises absorbent material (50) that comprises superabsorbent polymer material (e.g. particles), optionally combined with cellulosic material (including for example cellulose, comminuted wood pulp in the form of fibers). The further material described above (e.g. a further, second absorbent structure (13')) may include an absorbent material, and the following may apply thereto too.

15 In some embodiment, the absorbent material (50) may comprise at least 60%, or at least 70% by weight of superabsorbent polymer material, and at the most 40% or at the most 30% of cellulosic material.

20 In some other embodiments, the absorbent layer (17) comprises absorbent material (50) that consists substantially of absorbent polymer material, e.g. particles, e.g. less than 5% by weight (of the absorbent material (50)) of cellulosic material is present; and said absorbent layer (17)/ absorbent structure (13), may be free of cellulosic material.

25 Typically, the superabsorbent polymer material is in the form of particles. Suitable for use in the absorbent layer (17) can comprise any superabsorbent polymer particles known from superabsorbent literature, for example such as described in Modern Superabsorbent Polymer Technology, F.L. Buchholz, A.T. Graham, Wiley 1998. The absorbent polymer particles may be spherical, spherical-like or irregular shaped particles, such as Vienna-sausage shaped particles, or ellipsoid shaped particles of the kind typically obtained from inverse phase suspension polymerizations. The particles can also be optionally agglomerated at least to some extent to form larger irregular particles.

30 In some embodiments herein, the absorbent material (50) as a whole and/ or said particulate superabsorbent polymer material at least, has a high sorption capacity, e.g. having a CRC of for example at least 20 g/g, or at 30 g/g. Upper limits may for example be up to 150 g/g, or up to 100 g/g.

In some embodiments herein, the absorbent material (50) comprising or consisting of superabsorbent polymer particles that are formed from polyacrylic acid polymers/ polyacrylate polymers, for example having a neutralization degree of from 60% to 90%, or about 75%, having for example sodium counter ions.

5 The superabsorbent polymer may be polyacrylates and polyacrylic acid polymers that are internally and/ or surface cross-linked. Suitable materials are described in the PCT Patent Application WO 07/047598 or for example WO 07/046052 or for example WO2009/155265 and WO2009/155264. In some embodiments, suitable superabsorbent polymer particles may be
10 obtained by current state of the art production processes as is more particularly described in WO 2006/083584. The superabsorbent polymers may be internally cross-linked, i.e. the polymerization is carried out in the presence of compounds having two or more polymerizable groups which can be free-radically copolymerized into the polymer network. Useful crosslinkers include for example ethylene glycol dimethacrylate, diethylene glycol diacrylate, allyl methacrylate, trimethylolpropane triacrylate, triallylamine, tetraallyloxyethane as described in EP-A 530 438, di-
15 and triacrylates as described in EP-A 547 847, EP-A 559 476, EP-A 632 068, WO 93/21237, WO 03/104299, WO 03/104300, WO 03/104301 and in DE-A 103 31 450, mixed acrylates which, as well as acrylate groups, include further ethylenically unsaturated groups, as described in DE-A 103 31 456 and DE-A 103 55 401, or crosslinker mixtures as described for example in DE-A 195 43 368, DE-A 196 46 484, WO 90/15830 and WO 02/32962 as well as cross-linkers described in
20 WO2009/155265. The superabsorbent polymer particles may be externally surface cross-linked, or: post cross-linked). Useful post-crosslinkers include compounds including two or more groups capable of forming covalent bonds with the carboxylate groups of the polymers. Useful compounds include for example alkoxysilyl compounds, polyaziridines, polyamines, polyamidoamines, di- or polyglycidyl compounds as described in EP-A 083 022, EP-A 543 303 and EP-A 937 736,
25 polyhydric alcohols as described in DE-C 33 14 019, cyclic carbonates as described in DE-A 40 20 780, 2-oxazolidone and its derivatives, such as N-(2-hydroxyethyl)-2-oxazolidone as described in DE-A 198 07 502, bis- and poly-2-oxazolidones as described in DE-A 198 07 992, 2-oxotetrahydro-1,3-oxazine and its derivatives as described in DE-A 198 54 573, N-acyl-2-oxazolidones as described in DE-A 198 54 574, cyclic ureas as described in DE-A 102 04 937,
30 bicyclic amide acetals as described in DE-A 103 34 584, oxetane and cyclic ureas as described in EP-A 1 199 327 and morpholine-2,3-dione and its derivatives as described in WO 03/031482.

The superabsorbent polymers or particles thereof may have surface modifications, such as being coated or partially coated with a coating agent. Examples of coated absorbent polymer

particles are disclosed in WO2009/155265. The coating agent may be such that it renders the absorbent polymer particles more hydrophilic. For example, it may be hydrophilic (i.e. fumed) silica, such as Aerosils. The coating agent may be a polymer, such as an elastic polymer or a film-forming polymer or an elastic film-forming polymer, which forms an elastomeric (elastic) film coating on the particle. The coating may be a homogeneous and/or uniform coating on the surface of the absorbent polymer particles. The coating agent may be applied at a level of from 0.1% to 5%.

The superabsorbent polymer particles may have a particle sizes in the range from 45 μm to 4000 μm , more specifically a particle size distribution within the range of from 45 μm to about 2000 μm , or from about 100 μm to about 1000 or to 850 μm . The particle size distribution of a material in particulate form can be determined as it is known in the art, for example by means of dry sieve analysis (EDANA 420.02 "Particle Size distribution).

In some embodiments herein, the superabsorbent material is in the form of particles with a mass medium particle size up to 2 mm, or between 50 microns and 2 mm or to 1 mm, or from 100 or 200 or 300 or 400 or 500 μm , or to 1000 or to 800 or to 700 μm ; as can for example be measured by the method set out in for example EP-A-0691133. In some embodiments of the disclosure, the superabsorbent polymer material is in the form of particles whereof at least 80% by weight are particles of a size between 50 μm and 1200 μm and having a mass median particle size between any of the range combinations above. In addition, or in another embodiment of the disclosure, said particles are essentially spherical. In yet another or additional embodiment of the disclosure the superabsorbent polymer material has a relatively narrow range of particle sizes, e.g. with the majority (e.g. at least 80%, at least 90% or even at least 95% by weight) of particles having a particle size between 50 μm and 1000 μm , between 100 μm and 800 μm , between 200 μm and 600 μm .

Supporting sheet (16; 16')

The absorbent structure (13) herein comprises a supporting sheet (16) on which said absorbent material (50) is supported and immobilized. The further material may be or include a supporting sheet (16'), and the following applies also to such a sheet (16').

This supporting sheet (16) may be an individual sheet or a web material that is subsequently divided in to individual absorbent structure (13)s, in particular paper, films, wovens or nonwovens, or laminate of any of these.

In some embodiments herein, the supporting sheet (16) is a nonwoven, e.g. a nonwoven web, such as a carded nonwoven, spunbond nonwoven or meltblown nonwoven, and including nonwoven laminates of any of these.

5 The fibers may be of natural or man-made origin and may be staple or continuous filaments or be formed in situ. Commercially available fibers have diameters ranging typically from less than about 0.001 mm to more than about 0.2 mm and they come in several different forms: short fibers (known as staple, or chopped), continuous single fibers (filaments or monofilaments), untwisted bundles of continuous filaments (tow), and twisted bundles of continuous filaments (yarn). The fibers may be bicomponent fibers, for example having a sheath-core arrangement, e.g.
10 with different polymers forming the sheath and the core. Nonwoven fabrics can be formed by many processes such as meltblowing, spunbonding, solvent spinning, electrospinning, and carding. The basis weight of nonwoven fabrics is usually expressed in grams per square meter (gsm).

The nonwoven herein may be made of hydrophilic fibers; "Hydrophilic" describes fibers or surfaces of fibers, which are wettable by aqueous fluids (e.g. aqueous body fluids) deposited on
15 these fibers. Hydrophilicity and wettability are typically defined in terms of contact angle and the strike through time of the fluids, for example through a nonwoven fabric. This is discussed in detail in the American Chemical Society publication entitled "Contact angle, wettability and adhesion", edited by Robert F. Gould (Copyright 1964). A fiber or surface of a fiber is said to be wetted by a fluid (i.e. hydrophilic) when either the contact angle between the fluid and the fiber,
20 or its surface, is less than 90°, or when the fluid tends to spread spontaneously across the surface of the fiber, both conditions are normally co-existing. Conversely, a fiber or surface of the fiber is considered to be hydrophobic if the contact angle is greater than 90° and the fluid does not spread spontaneously across the surface of the fiber.

The supporting sheet (16) herein may be air-permeable. Films useful herein may therefore
25 comprise micro pores. Nonwovens herein may for example be air permeable. The supporting sheet (16) may have for example an air-permeability of from 40 or from 50, to 300 or to 200 m³/ (m²x min), as determined by EDANA method 140-1-99 (125 Pa, 38.3 cm²). The supporting sheet (16) may alternatively have a lower air-permeability, e.g. being non-air-permeable, to for example be better detained on a moving surface comprising vacuum.

30 In some executions, the supporting sheet (16) is a nonwoven laminate material, a nonwoven laminate web, for example of the SMS or SMMS type.

In order to form easily said undulations, the supporting sheet (16) may have a basis weight that is less than 60 gsm, or for example than 50 gsm, for example from 5 gsm to 40 gsm, or to 30 gsm.

The supporting sheet (16) may have a CD-extensibility or a MD-extensibility.

5 In one of the embodiment herein, the supporting sheet (16) has undulations that fold (undulate) into said first and second channels (26), and optionally in to said further channel(s), of part thereof. For example the undulations may extend over about the full longitudinal dimension of the channel; they may for example extend to complete average height of the absorbent layer (17)/ channel, or for example only up to 75% thereof, or up to 50% of the average height of the
10 absorbent layer (17)/ channel. This aids immobilization of the absorbent material (50) adjacent said channels (26) and said channels (26) of said layers.

The undulations may be adhered with said one or more adhesive material, e.g. said second adhesive material, to said walls of said channels (26),. The supporting sheet (16) may alternatively, or in addition, be adhered in said channels (26) to said further material, e.g. second supporting
15 sheet (16), describe herein above, e.g. with said first and/ or second adhesive.

Adhesive material

The absorbent structure (13) may comprise one or more adhesive materials. In some embodiments, it comprises a first adhesive material and/or a second adhesive material, as described
20 above, and in the manner described above.

The absorbent core herein may comprise a further second absorbent structure (13') that may comprise one or more adhesive materials; the following equally applies thereto.

Any suitable adhesive can be used for this, for example so-called hotmelt adhesives used. For example, a sprayable hot melt adhesives, such as H.B. Fuller Co. (St. Paul, MN) Product No.
25 HL-1620-B, can be used.

The adhesive material(s) may not only help in immobilizing the absorbent material on the supporting sheet but it may also help in maintaining the integrity of the channels in the absorbent structure absorbent core during storage and/or during use of the disposable article. The adhesive material may help to avoid that a significant amount of absorbent material migrates into the
30 channels. Furthermore, when the adhesive material is applied in the channels or on the supporting sheet portions coinciding with the channels it may thereby help to adhere the supporting sheet of the absorbent structure to said walls, and/ or to a further material, as will be described in further details below.

In some embodiments, the first adhesive (40) and/ or the second adhesive (60) may be a thermoplastic adhesive material.

In some embodiments, the first adhesive (40) may be applied as fibers, forming a fibrous network that immobilizes the absorbent material on the supporting sheet. The thermoplastic adhesive fibers may be partially in contact with the supporting sheet of the absorbent structure; if applied also in the channels, it (further) anchors the absorbent layer to the supporting sheet.

The thermoplastic adhesive material may for example allow for such swelling, without breaking and without imparting too many compressive forces, which would restrain the absorbent polymer particles from swelling. Thermoplastic adhesive materials (40; 60) suitable for use in the present disclosure includes hot melt adhesives comprising at least a thermoplastic polymer in combination with a plasticizer and other thermoplastic diluents such as tackifying resins and additives such as antioxidants. Exemplary suitable hot melt adhesive materials (40; 60) are described in EP 1447067 A2. In some embodiments, the thermoplastic polymer has a molecular weight (Mw) of more than 10,000 and a glass transition temperature (Tg) below room temperature or $-6\text{ }^{\circ}\text{C} > \text{Tg} < 16\text{ }^{\circ}\text{C}$. In certain embodiments, the concentrations of the polymer in a hot melt are in the range of about 20 to about 40% by weight. In certain embodiments, thermoplastic polymers may be water insensitive. Exemplary polymers are (styrenic) block copolymers including A-B-A triblock structures, A-B diblock structures and (A-B)_n radial block copolymer structures wherein the A blocks are non-elastomeric polymer blocks, typically comprising polystyrene, and the B blocks are unsaturated conjugated diene or (partly) hydrogenated versions of such. The B block is typically isoprene, butadiene, ethylene/butylene (hydrogenated butadiene), ethylene/propylene (hydrogenated isoprene), and mixtures thereof.

Other suitable thermoplastic polymers that may be employed are metallocene polyolefins, which are ethylene polymers prepared using single-site or metallocene catalysts. Therein, at least one comonomer can be polymerized with ethylene to make a copolymer, terpolymer or higher order polymer. Also applicable are amorphous polyolefins or amorphous polyalphaolefins (APAO) which are homopolymers, copolymers or terpolymers of C2 to C8 alpha olefins.

The thermoplastic adhesive material, typically a hot-melt adhesive material, is generally present in the form of fibres, i.e. the hot melt adhesive can be fiberized. In some embodiments, the thermoplastic adhesive material forms a fibrous network over the absorbent polymer particles. Typically, the fibres can have an average thickness from about 1 μm to about 100 μm , or from about 25 μm to about 75 μm , and an average length from about 5 mm to about 50 cm. In particular the layer of hot melt adhesive material can be provided such as to comprise a net-like structure. In

certain embodiments the thermoplastic adhesive material is applied at an amount of from 0.5 to 30 g/m², or from 1 to 15 g/m², or from 1 and 10 g/m² or even from 1.5 and 5 g/m² per supporting sheet (16).

5 A typical parameter for an adhesive suitable for use in the present disclosure can be a loss angle tan Delta at 60°C of below the value of 1, or below the value of 0.5. The loss angle tan Delta at 60°C is correlated with the liquid character of an adhesive at elevated ambient temperatures. The lower tan Delta, the more an adhesive behaves like a solid rather than a liquid, i.e. the lower its tendency to flow or to migrate and the lower the tendency of an adhesive superstructure as described herein to deteriorate or even to collapse over time. This value is hence particularly
10 important if the absorbent article is used in a hot climate.

It may be beneficial, e.g. for process reasons and/or performance reasons, that the thermoplastic adhesive material has a viscosity of between 800 and 4000 mPa·s, or from 1000 mPa·s or 1200 mPa·s or from 1600 mPa·s to 3200 mPa·s or to 3000 mPa·s or to 2800 mPa·s or to 2500 mPa·s, at 175°C, as measurable by ASTM D3236-88, using spindle 27, 20 rpm, 20 minutes
15 preheating at the temperature, and stirring for 10 min.

The thermoplastic adhesive material may have a softening point of between 60°C and 150°C, or between 75°C and 135°C, or between 90°C and 130°C, or between 100°C and 115°C, as can be determined with ASTM E28-99 (Herzog method; using glycerine).

In one embodiment herein, the thermoplastic adhesive component may be hydrophilic,
20 having a contact angle of less than 90°, or less than 80° or less than 75° or less than 70°, as measurable with ASTM D 5725-99.

Signals

The absorbent articles of the present invention may comprise signals that communicate to
25 the consumer the functionality and benefits of the absorbent core channels. Non-limiting examples of such signals may include printed adhesive layers, backsheet graphics, embossing of the topsheet and/or acquisition layer, and combinations thereof.

One type of signal that may be used to communicate the existence and the benefits of the channels is a printed adhesive layer. In some embodiments, an article with channels in the core
30 may have a layer of an adhesive that is applied in a pattern that connotes the absorbency and other benefits of the channels. This adhesive layer may be applied to a substrate, such as a supporting layer, in some embodiments an acquisition layer, that may be positioned between a topsheet and

the absorbent core with channels. In some embodiments, the layer of printed adhesive may be visible through the topsheet.

In some embodiments, a fluid, such as an adhesive, may be applied or printed onto an advancing substrate. The fluid application apparatus may include a slot die applicator and a substrate carrier. The slot die applicator may include a slot opening, a first lip, and a second lip, the slot opening located between the first lip and the second lip. And the substrate carrier may include one or more pattern elements and may be adapted to advance the substrate past the slot die applicator as the slot die applicator discharges adhesive onto the substrate. In operation, when the first surface of the substrate is disposed on the substrate carrier, the substrate carrier advances the second surface of the substrate past the slot opening of the slot die applicator. In turn, the substrate is intermittently compressed between the slot die applicator and the pattern surface of the pattern element. As the substrate is intermittently compressed, adhesive discharged from the slot die applicator is applied onto the second surface of the advancing substrate in an area having a shape that is substantially the same as a shape defined by the pattern surface. In some embodiments, the adhesive may be a different color than the substrate. The adhesive may comprise pigments or dyes. Other methods and apparatuses involved for the application of adhesives in pre-determined patterns to an advancing substrate are disclosed in US Patent 8,186,296. In some embodiments, the fluid printed on the substrate may be an ink without an adhesive.

The term "pattern" as used herein means a decorative or distinctive design, not necessarily repeating or imitative, including but not limited to the following: marbled, check, mottled, veined, clustered, geometric, spotted, helical, swirl, arrayed, variegated, textured, spiral, cycle, contoured, laced, tessellated, starburst, lobed, lightning, blocks, textured, pleated, cupped, concave, convex, braided, tapered, and combinations thereof. Examples of patterns for the printed adhesive layer may be seen in Figures 17A, 17B, 17C, and 18. In Figs. 17A to 17C, the curved lines of the printed adhesive layer, and in Fig. 18, the pattern of the printed adhesive layer, may signal to the consumer one or more benefits of the channels. For example, the channels may act as a conduit, distributing fluid to a more comfortable place, while the printed adhesive layer, visible to the caregiver through the topsheet, may signal or communicate the fluid distribution and comfort that the article can provide.

As discussed above, the absorbent structure of the present invention typically comprises one or more further materials, such as a further material layer, to cover the absorbent layer. This layer may comprise an adhesive, for example on the surface that is to contact the absorbent layer of the absorbent structure. Thus, the further material may comprise on the surface to be placed

adjacent said absorbent layer of the absorbent structure, an adhesive material. In some embodiments, the further material layer may be an acquisition material layer that may have the adhesive printed onto it to form a patterned appearance. Thus, the adhesive is printed onto the surface of the acquisition layer that is adjacent to the absorbent core. In addition to an absorbent core with channels and a printed adhesive layer printed onto the surface of the acquisition layer adjacent to the absorbent core, the article may also comprise a topsheet, wherein the printed adhesive layer is visible through the topsheet. In some embodiments, the printing (ink or an adhesive with ink) may be on the topsheet itself, and where ink is the substance being printed, the printing may be performed using digital printing.

10 In some embodiments, the absorbent article may comprise graphics printed onto the backsheet. As the absorbent core is loaded with fluid, the absorbent material will expand in particular towards the backsheet, while the channels which do not comprise absorbent material will not expand. This difference may be used, as the channels will become more perceptible through the backsheet as fluid is absorbed as they may form depressions. These depressions will become more pronounced as the absorbent article absorbs the fluid.

15 The depth of these depressions formed by the channels on the backsheet side will be proportional to the amount of fluid absorbed, and the inventors have found that that the visual appearance to the caregiver may be improved by providing a backsheet printing which matches or at least indicates the region of the channels to the caregiver. Thus the backsheet printing may comprise a line or a curve which substantially matches the shape and/or position of the channels.

20 Backsheet graphics, for example, as shown in Figures 15 and 16, may similarly signal to the caregiver the attributes of the channels. In some embodiments, the only visual signal of the channels may be the backsheet printing. In some embodiments, the backsheet printing may be curves, lines, or other patterns that approximate the shape and contours of the channels. In some embodiments, the article may comprise both a printed adhesive layer and backsheet graphics, the combination of which work together or separately to accentuate certain channel aspects.

25 As shown in Fig. 19, backsheet graphics that approximate the shape and contours of the channels may be arranged such that they fit within the absorbent core area of the absorbent article without extending beyond such area, thereby providing a caregiver a clearer communication of the benefits of the channels. An exemplary backsheet containing graphics that approximate the shape and contours of the underlying channels is depicted. The length A' of the backsheet in the machine direction may be, e.g. 478 mm, and its width P' in the cross-direction may be 196 mm. A centerline in the machine direction of the backsheet is shown by Line C', and thus the half length B' is 239

mm. The distance between the graphics that visually signal the inner channels is shown as the distance F' between lines D' and E', taken along centerline C'. The distance F' may be 22 mm. The distance between the graphics that visually signal the outer channels is shown as the distance I' between lines G' and H', taken along Line J'. The distance I' may be 37.5 mm. Lines J' and K' are drawn parallel to centerline C' and are taken along the terminating points of the graphics visually signaling the inner channels, termination referring to the points at which the graphics end, starting from centerline C'. The distance between these terminating points, in the machine direction is shown by Line L'. This distance may be 198 mm. Lines M' and N' are drawn parallel to centerline C' and are taken along the terminating points of the graphics visually signaling the outer channels, termination referring to the points at which the graphics end, starting from centerline C'. The distance between these terminating points, in the machine direction is shown by Line O'. This distance may be 158 mm. The distance between the graphics visually signaling the inner channels and graphics visually signaling the outer channels, taken along Line C', may be 6 mm. In a preferred embodiment, where all lengths are given in mm: A' = 478; P' = 206; L' = 205; O' = 165; I' = 43; and F' = 22.

The relative lengths of any of the lines above may be expressed as ratios, and may be exact, or may be expressed with a tolerance of plus or minus 2%, 3%, 4%, 5%, 7%, or 10%, alone or in combination with other ratios of lengths, and the length may be rounded to the nearest whole number or multiple of 5, after the percent of tolerance is applied.

Applicants have found that ratios particularly important in signaling one or more benefits of the channels are those of: (a) A' to L'; (b) B' to L'; and (c) P' to F'. In some embodiments: the A' to L' ratio will range from 2.2 to 2.7, preferably from 2.3 to 2.5, more preferably it will be 2.4. In some embodiments: the B' to L' ratio will range from 1.0 to 1.4, preferably from 1.1 to 1.3, more preferably it will be 1.2. In some embodiments: the P' to F' ratio will range from 8.0 to 9.8, preferably from 8.5 to 9.4, more preferably it will be 8.9.

Further, in some embodiments, the graphics visually signaling the inner channels will not extend beyond the area of the outer channels themselves, and/or the area where the absorbent core is present, and in some embodiments, the graphics visually signaling the outer channels will not extend beyond the area of the outer channels themselves, and/or the area where the absorbent core is present, and in some embodiments, the graphics visually signaling the inner and outer channels will not extend beyond the area of the inner and outer channels themselves, and/or the area where the absorbent core is present.

In addition, the article may comprise other or additional visual cues that signal the absorbent core channels, such as, for example, embossing. Embossing may be done on the topsheet or on the absorbent core, or, in some embodiments, there may be multi-layer embossing of both the topsheet and the absorbent core. For example, thermal embossing may be done over the channels (where there is no superabsorbent polymer) at a small gap setting to enhance the visual presence. Any embossing may be done alone or in combination with printing to help signal the absorbent core channels. Further, any embossing may be done to the topsheet, core, or both, on-line (during assembly of the absorbent article's component parts) or prior to such assembly, e.g. at the site where a supplier of component parts makes the component part itself.

In some embodiments, the printed adhesive layer or the backsheet printing may be a pattern that covers the majority or even all of the absorbent core. In other embodiments, the printed adhesive layer or backsheet printing may be printed only in discrete areas. For example, in some embodiments, the printed adhesive layer or backsheet printing may be printed so as to not overlap or intersect with the absorbent core channels. The term "overlap" as used herein means to cover over a part of, or to have an area in common. The term "intersect" as used herein means items that cut across or through each other, or that narrow and merge.

In order to ensure that absorbent article components (including graphic absorbent article components) are properly oriented when attached to other absorbent article components, registration may be used. Registration may include using a system to detect a location on an absorbent article component and to compare the location against a set point (which may be an operator desired or machine set location). The system may adjust placement of the absorbent article component in accordance with said comparison. For example, the location of absorbent core channels and a printed adhesive layer may be detected and a repeat length of the printed adhesive layer may be altered via a length control system (described in U.S. Patent Nos. 6,444,064 and 6,955,733). Alternatively, a system may be used to detect and control the longitudinal or machine direction position of a component relative to a desired position on the absorbent article wherein the position at which subsequent occurrences of a first component is attached to a second component is altered to ensure the first component is in the desired location. Such can be performed based on multiple detections and the use of an averaging position, deviation from the desired position, or by detecting less frequently than every occurrence. Additionally, a system may detect a first location on a first absorbent article component and a second location on a second absorbent article component, where the first and second locations may be compared relative to each other and against a set point or desired offset position. The system may adjust placement of

the first and/or second absorbent article components in accordance with said comparison. Combinations of detection methods may be used. In some embodiments, registration may be used to optimize the visual impression of the printing and the absorbent core channels.

5 In some embodiments, any printing, whether a printed adhesive layer, a backsheet graphic, or some combination, may match, or substantially match the shape or contour of the absorbent core channels. In some embodiments, the printing will not necessarily match or correlate with the shape or contour of the absorbent core channels, but will otherwise communicate or signal to the consumer the existence and/or benefits of the channels.

10 Absorbent articles, e.g. diapers

The absorbent structure (13) or absorbent core (7) herein may be useful in an absorbent article, such as described above, and in particular in a diaper (1), including fastenable diapers (1) and (refastenable) training pants, for infants or for adults, or in an absorbent pad, such as a sanitary napkin or adult incontinence undergarment pad.

15 The article may comprise, in addition to an absorbent structure (13) or absorbent core (7) as described herein, a topsheet and backsheet, and for example one or more side flaps or cuffs. The topsheet or cuffs or side flaps may comprise a skin care composition or lotion or powder, known in the art, panels, including those described in U.S. 5,607,760; U.S. 5,609,587; U.S. 5,635,191; U.S. 5,643,588.

20 Articles herein comprise a topsheet, facing the wearer in use, for example a nonwoven sheet, and/ or an apertured sheet, including apertured formed films, as known in the art, and a backsheet.

The backsheet may be liquid impervious, as known in the art. In some embodiments, the liquid impervious backsheet comprises a thin plastic film such as a thermoplastic film having a
25 thickness of about 0.01 mm to about 0.05 mm. Suitable backsheet materials comprise typically breathable material, which permit vapors to escape from the diaper (1) while still preventing exudates from passing through the backsheet. Suitable backsheet films include those manufactured by Tredegar Industries Inc. of Terre Haute, IN and sold under the trade names X15306, X10962 and X10964.

30 The backsheet, or any portion thereof, may be elastically extendable in one or more directions. The backsheet may be attached or joined to a topsheet, the absorbent structure / core, or any other element of the diaper (1) by any attachment means known in the art.

Diapers herein may comprise leg cuffs and / or barrier cuffs; the article then typically has a pair of opposing side flaps and/ or leg and/ or barrier cuffs, each of a pair being positioned adjacent one longitudinal side of the absorbent structure/ core, and extending longitudinally along said structure/ core, and typically being mirror images of one another in the longitudinal-axis of the article; if leg cuffs and barrier cuffs are present, then each leg cuffs is typically positioned outwardly from a barrier cuff. The cuffs may be extending longitudinally along at least 70% of the length of the article. The cuff(s) may have a free longitudinal edge that can be positioned out of the X-Y plane (longitudinal/ transverse directions) of the article, i.e. in z-direction. The side flaps or cuffs of a pair may be mirror images of one another in the longitudinal axis of the article.

10 The cuffs may comprise elastic material.

The diapers herein may comprise a waistband, or for example a front waistband and back waist band, which may comprise elastic material.

The diaper (1) may comprise side panels, or so-called ear panels. The diaper (1) may comprise fastening means, to fasten the front and back, e.g. the front and back waistband. Fastening systems may comprise fastening tabs and landing zones, wherein the fastening tabs are attached or joined to the back region of the diaper (1) and the landing zones are part of the front region of the diaper (1).

15

The absorbent structure (13) may be combined with, and the absorbent core (7) or diaper (1) may comprise, an acquisition layer (12) and/or acquisition material layer (70), or system thereof this may comprise chemically cross-linked cellulosic fibers. Such cross-linked cellulosic fibers may have desirable absorbency properties. Exemplary chemically cross-linked cellulosic fibers are disclosed in US Patent No. 5,137,537. In certain embodiments, the chemically cross-linked cellulosic fibers are cross-linked with between about 0.5 mole % and about 10.0 mole % of a C₂ to C₉ polycarboxylic cross-linking agent or between about 1.5 mole % and about 6.0 mole % of a C₂ to C₉ polycarboxylic cross-linking agent based on glucose unit. Citric acid is an exemplary cross-linking agent. In other embodiments, polyacrylic acids may be used. Further, according to certain embodiments, the cross-linked cellulosic fibers have a water retention value of about 25 to about 60, or about 28 to about 50, or about 30 to about 45. A method for determining water retention value is disclosed in US Patent No. 5,137,537. According to certain embodiments, the cross-linked cellulosic fibers may be crimped, twisted, or curled, or a combination thereof including crimped, twisted, and curled.

20

25

30

In a certain embodiment, one or both of the upper and lower acquisition layers may comprise a non-woven, which may be hydrophilic. Further, according to a certain embodiment,

one or both of the upper and lower acquisition layers may comprise the chemically cross-linked cellulosic fibers, which may or may not form part of a nonwoven material. According to an exemplary embodiment, the upper acquisition layer may comprise a nonwoven, without the cross-linked cellulosic fibers, and the lower acquisition layer may comprise the chemically cross-linked cellulosic fibers. Further, according to an embodiment, the lower acquisition layer may comprise the chemically cross-linked cellulosic fibers mixed with other fibers such as natural or synthetic polymeric fibers. According to exemplary embodiments, such other natural or synthetic polymeric fibers may include high surface area fibers, thermoplastic binding fibers, polyethylene fibers, polypropylene fibers, PET fibers, rayon fibers, lyocell fibers, and mixtures thereof. Suitable non-woven materials for the upper and lower acquisition layers include, but are not limited to SMS material, comprising a spunbonded, a melt-blown and a further spunbonded layer. In certain embodiments, permanently hydrophilic non-wovens, and in particular, nonwovens with durably hydrophilic coatings are desirable. Another suitable embodiment comprises a SMMS-structure. In certain embodiments, the non-wovens are porous.

The diaper (1) may include a sub-layer disposed between the topsheet and the absorbent structure (13)/ absorbent core (7), capable of accepting, and distributing and/ or immobilizing bodily exudates. Suitable sublayers include acquisition layers, surge layers and or fecal material storage layers, as known in the art. Suitable materials for use as the sub-layer may include large cell open foams, macro-porous compression resistant non woven highlofts, large size particulate forms of open and closed cell foams (macro and/or microporous), highloft non-wovens, polyolefin, polystyrene, polyurethane foams or particles, structures comprising a multiplicity of vertically oriented, looped, strands of fibers, or apertured formed films, as described above with respect to the genital coversheet. (As used herein, the term "microporous" refers to materials that are capable of transporting fluids by capillary action, but having a mean pore size of more than 50 microns. The term "macroporous" refers to materials having pores too large to effect capillary transport of fluid, generally having pores greater than about 0.5 mm (mean) in diameter and more specifically, having pores greater than about 1.0 mm (mean) in diameter, but typically less than 10 mm or even less than 6 mm (mean).

Processes for assembling the absorbent article or diaper (1) include conventional techniques known in the art for constructing and configuring disposable absorbent articles. For example, the backsheets and/or the topsheet can be joined to the absorbent structure/ core or to each other by a uniform continuous layer of adhesive, a patterned layer of adhesive, or an array of separate lines, spirals, or spots of adhesive. Adhesives which have been found to be satisfactory are manufactured

by H. B. Fuller Company of St. Paul, Minnesota under the designation HL-1258 or H-2031. While the topsheet, the backsheet, and the absorbent structure (13)/ core may be assembled in a variety of well-known configurations, diaper (1) configurations are described generally in U.S. Pat. No. 5,554,145 entitled "Absorbent Article With Multiple Zone Structural Elastic-Like Film Web Extensible Waist Feature" issued to Roe et al. on Sep. 10, 1996; U.S. Pat. No. 5,569,234 entitled "Disposable Pull-On Pant" issued to Buell et al. on Oct. 29, 1996; and U.S. Pat. No. 6,004,306 entitled "Absorbent Article With Multi-Directional Extensible Side Panels" issued to Robles et al. on Dec. 21, 1999.

10 Method of making the absorbent structure (13)

The absorbent structure (13) herein may be made by any method comprising the step of depositing absorbent material (50) onto a supporting sheet (16), for example by pacing first said supporting sheet (16) onto raised portions in the shape and dimensions of said channels (26) to be produced and then depositing said absorbent material (50) thereon; thereby, the absorbent material
15 (50) does not remain onto said raised portions, but only on the remaining portions of the supporting sheet (16).

In some embodiments, the absorbent structure (13) with the absorbent layer (17) with therein two or more channels (26) with substantially no absorbent material (50) is for example obtainable by a method comprising the steps of:

- 20 a) providing a feeder for feeding said absorbent material (50) to a first moving endless surface, such as a hopper;
- b) providing a transfer means for transferring a supporting sheet (16) to a second moving endless surface;
- 25 c) providing a first moving endless surface, having one or more absorbent layer (17)-forming reservoirs with a longitudinal dimension and averaged length, a perpendicular transverse dimension and average width, and, perpendicular to both, a depth dimension and average depth, and a void volume for receiving said absorbent material (50) therein, said reservoir(s) comprising one or more substantially longitudinally extending raised strips, not having a void volume, for example each having an average width W of at least 4% or at
30 least 5% of the average width of the reservoir, and an average length L of at least 5% and at the most 30% of the average longitudinal dimension of the reservoir; said reservoir(s) being for transferring said absorbent material (50) to said second moving endless surface adjacent and in proximity thereto

d) providing a second moving surface, having an outer shell that has one or more air permeable or partially air permeable receptacles with for receiving said supporting sheet (16) thereon or therein, with a receiving area and with one or more substantially longitudinally extending mating strips that may be air impermeable, and having each an average width of for example W' of at least 2.5 mm, from $0.5 \times W$ to $1.2 \times W$, an average length of for example L' being from about $0.8 \times L$ to $1.2 \times L$;

whereby said air-permeable outer shell is connected to one or more secondary vacuum systems for facilitating retention of supporting sheet (16) and/or said absorbent material (50) thereon, and

whereby, in a meeting point, said first moving endless surface and said outer shell are at least partially adjacent to one another and in close proximity of one another during transfer of said absorbent material (50) and such that each mating strip is substantially completely adjacent and in close proximity to a raised strip during transfer of said absorbent material (50);

e) feeding with said feeder an absorbent material (50) to said first moving endless surface, in at least said reservoir (s) thereof;

f) optionally, removing any absorbent material (50) on said raised strips (s);

g) simultaneously, transferring said supporting sheet (16) to said second moving endless surface, onto or into said receptacle(s);

h) selectively transferring in said meeting point, said absorbent material (50) with said first moving endless surface only to said part of the supporting sheet (16) that is on or in said receiving area of said receptacle; and

i) 1) applying an adhesive material (i.e. a first adhesive material (40)) to said absorbent structure (13) of step g; and/ or

i) 2) applying an adhesive material (i.e. a second adhesive material (60)) to said supporting sheet (16), prior or step f, or simultaneously therewith, but in any event prior to step g).

Step i) 1) may involve spraying said first adhesive material in the form of fibers onto said absorbent layer (17), or part thereof, for example substantially continuously, so it is also present in said channels (26).

Step i) 2) may involve slot coating or spray-coating the supporting sheet (16), either continuously, or for example in a pattern corresponding to the channel (26) pattern.

Said reservoir(s) may be formed by of a multitude of grooves and/ or cavities with a void volume, for receiving said absorbent material (50) therein. In some embodiments, the average

width W of (each) strip may be at least 6 mm, or for example at least 7 mm, and/or at least at least 7%, or for example at least 10% of the average width of the respective reservoir.

Said grooves and/ or cavities may each for example have a maximum dimension in transverse direction which is at least 3 mm, and whereby the shortest distance between directly neighboring cavities and /or grooves in substantially transverse dimension, is less than 5 mm. Cavities and/ or grooves that are directly adjacent a raised strip may have a volume that is more than the volume of one or more, or all of their neighboring cavities or grooves, that are not directly adjacent said strip or another strip (thus further removed from a strip).

Said first moving endless surface's reservoir may be at least partially air permeable and said first moving endless surface may have a cylindrical surface with said reservoirs, rotatably moving around a stator, comprising a vacuum chamber; said second moving surface's outershell may be cylindrical, rotatably moving around a stator, comprising a secondary vacuum chamber connected to said secondary vacuum system.

The method may be to produce an absorbent core (7) or structure that comprises two or more of the above described absorbent structures (13;13'); for example two such layers, superposed on one another such that the absorbent material (50) of a first layer and the absorbent material (50) of the other second layer are adjacent one another and sandwiched between the supporting sheet (16) of the first layer and the supporting sheet (16) of the second layer.

The method may involve the provision of a pressure means, such as a pressure roll, that can apply pressure onto the absorbent structure (13), and typically an absorbent structure (13) whereby the absorbent material (50) is sandwiched between the supporting sheet (16) a further material; the pressure may be applied onto said supporting sheet (16) or on any of the further material/ layer that placed over the absorbent layer (17), as described above in this section. This pressure application may be done to selectively apply pressure only onto the channels (26 and/or 26') of the absorbent structure (13), e.g. on the portions of the supporting sheet (16) that correspond to the channels (26), and that thus not comprise (on the opposed surface) absorbent material (50), to avoid compaction of said absorbent material (50) itself and/or on the portions of the further material, e.g. the supporting sheet (16') thereof, that correspond to the channels (26'), and that thus not comprise (on the opposed surface) absorbent material (50), to avoid compaction of said absorbent material (50) itself .

Thus, the pressure means may have a raised pressuring pattern corresponding to said pattern of the raised strip(s) and/or of said mating strip(s), in some corresponding to the pattern of the mating strip(s).

The dimensions and values disclosed herein are not to be understood as being strictly limited to the exact numerical values recited. Instead, unless otherwise specified, each such dimension is intended to mean both the recited value and a functionally equivalent range surrounding that value. For example, a dimension disclosed as “40 mm” is intended to mean “about
5 40 mm.”

The citation of any document, including any cross referenced or related patent or application is not an admission that it is prior art with respect to any invention disclosed or claimed herein or that it alone, or in any combination with any other reference or references, teaches, suggests or discloses any such invention. Further, to the extent that any meaning or definition of
10 a term in this document conflicts with any meaning or definition of the same term in a document cited herein, the meaning or definition assigned to that term in this document shall govern.

While particular embodiments of the present invention have been illustrated and described, it would be obvious to those skilled in the art that various other changes and modifications can be made without departing from the invention described herein.

What is claimed is:

1. An absorbent article comprising:
a topsheet, a backsheet, an absorbent core disposed between the topsheet and the backsheet, and an acquisition layer disposed between the topsheet and the absorbent core;
wherein the absorbent core comprises channels, the channels being free of absorbent material and extending through the thickness of said absorbent core;
wherein a patterned layer of adhesive is printed on a surface of at least one of the topsheet, backsheet, and the acquisition layer;
wherein the adhesive bonds the surface of at least one of the topsheet, backsheet and acquisition layer to an adjacent surface of the absorbent core; and
wherein the channels and the printed adhesive layer do not overlap.
2. The absorbent article of Claim 1, wherein the adhesive layer is free of ink.
3. The absorbent article of Claim 1, wherein the adhesive layer comprises a mixture of adhesive and ink.
4. The absorbent article of any one of Claims 1 to 3, wherein the printing of the adhesive layer is performed using digital printing.
5. The absorbent article of any one of Claims 1 to 4, wherein the acquisition layer has a surface that is adjacent to the absorbent core, and the adhesive layer is printed on the acquisition layer surface that is adjacent to the absorbent core.
6. The absorbent article of Claim 5, further comprising printed graphics on the backsheet.
7. The absorbent article of any one of Claims 1 to 4, wherein the printed adhesive layer is on the backsheet.
8. The absorbent article of any one of Claims 1 to 4, wherein the printed adhesive layer is on the topsheet.

9. The absorbent article of any one of Claims 1 to 8, wherein registration is used so that the channels and the printed adhesive layer do not overlap.
10. The absorbent article of any one of Claims 1 to 9, wherein the printed adhesive layer is a signal that communicates one or more benefits of the absorbent core channels to a consumer.
11. An absorbent article comprising:
 - a topsheet, a backsheet, an absorbent core disposed between the topsheet and the backsheet, and an acquisition layer disposed between the topsheet and the absorbent core;
 - wherein the absorbent core comprises curved channels, the channels being free of absorbent material and extending through the thickness of said absorbent core;
 - wherein graphics are printed on the backsheet;
 - wherein the acquisition layer has a surface that is adjacent to the absorbent core;
 - wherein a patterned layer of adhesive is printed on the surface of the acquisition layer that is adjacent to the absorbent core, the adhesive bonding the surface of the acquisition layer to the adjacent surface of the absorbent core; and
 - wherein the printed adhesive layer and the backsheet graphics match.
12. The absorbent article of Claim 11, wherein the curved channels have a shape and the backsheet graphics match the shape of the curved channels.
13. The absorbent article of Claim 11, wherein the curved channels have a contour and the backsheet graphics match the contour of the curved channels.
14. The absorbent article of Claim 11, wherein the printed adhesive layer is a signal that communicates one or more benefits of the absorbent core channels to a consumer.

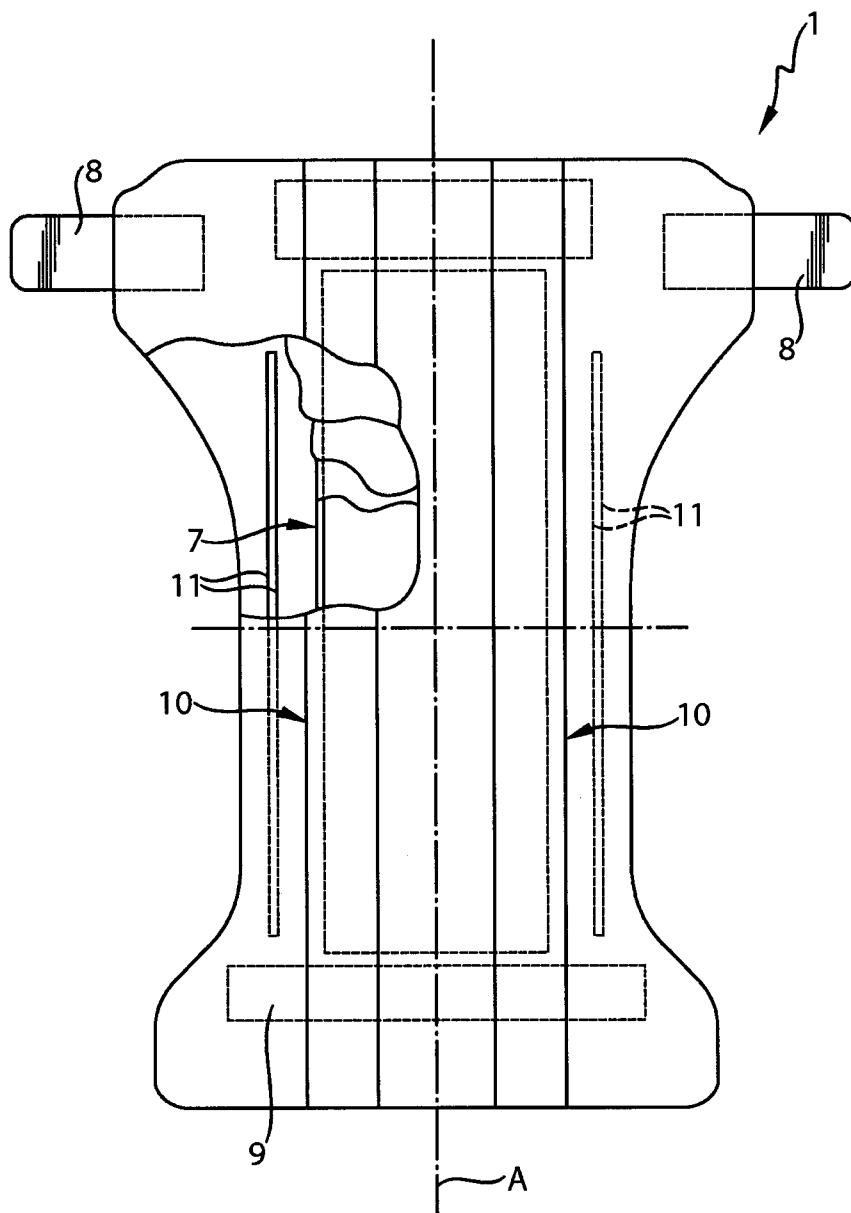

Fig. 1

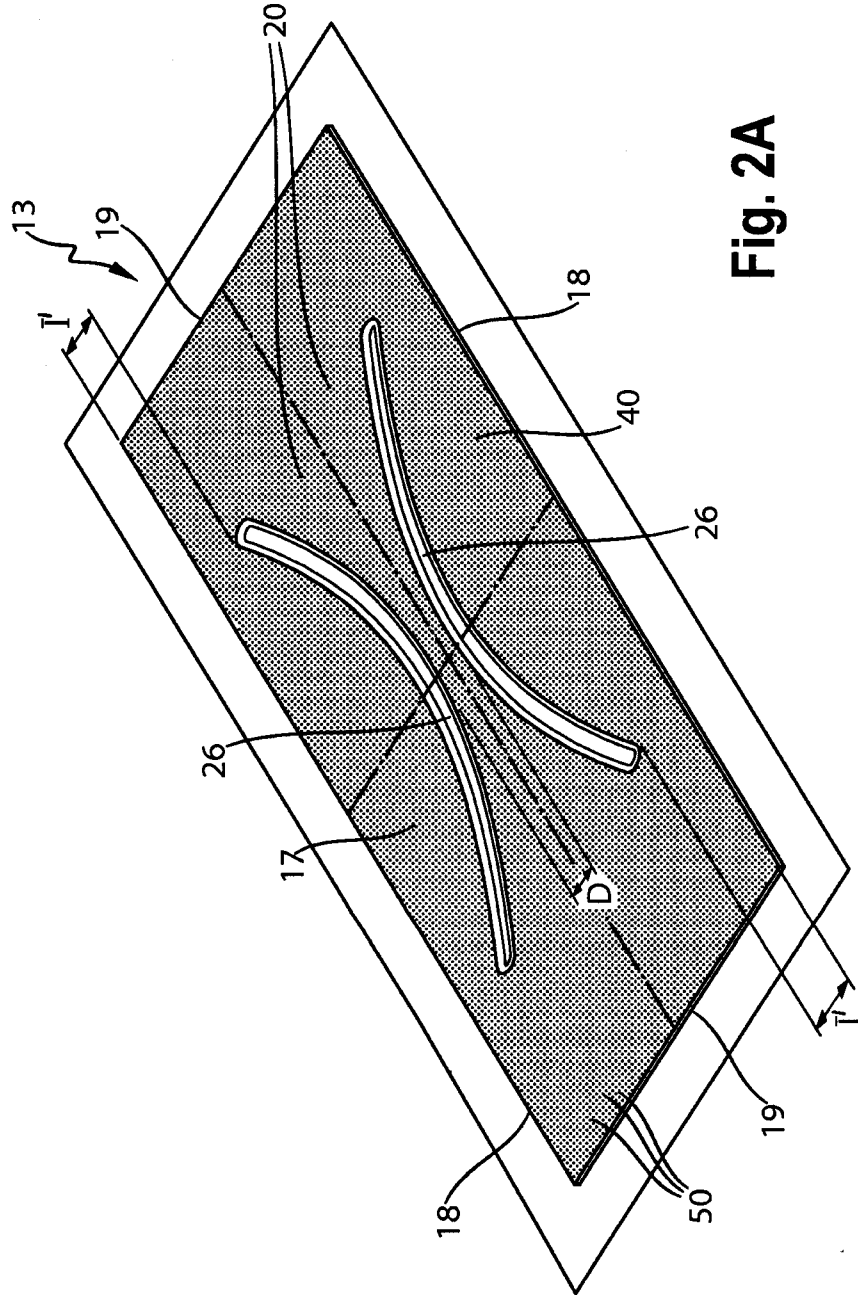

Fig. 2A

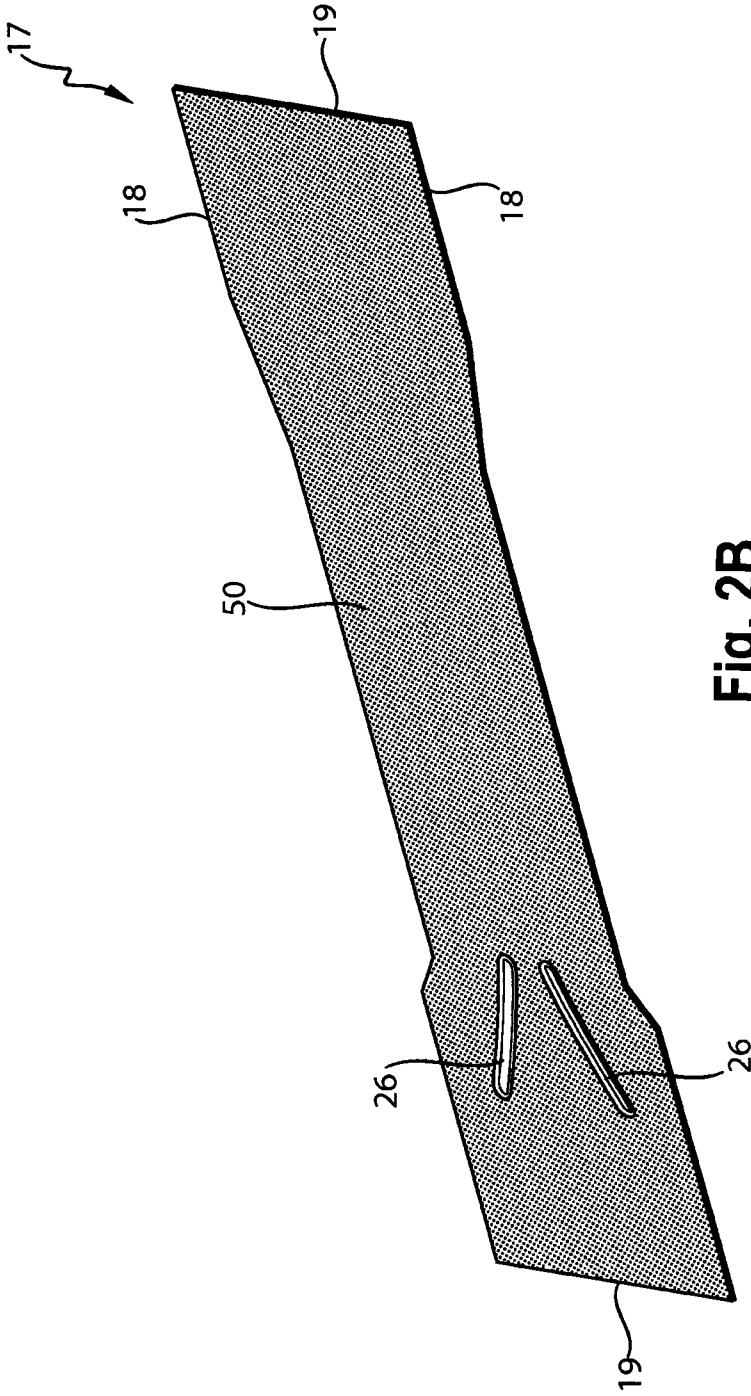

Fig. 2B

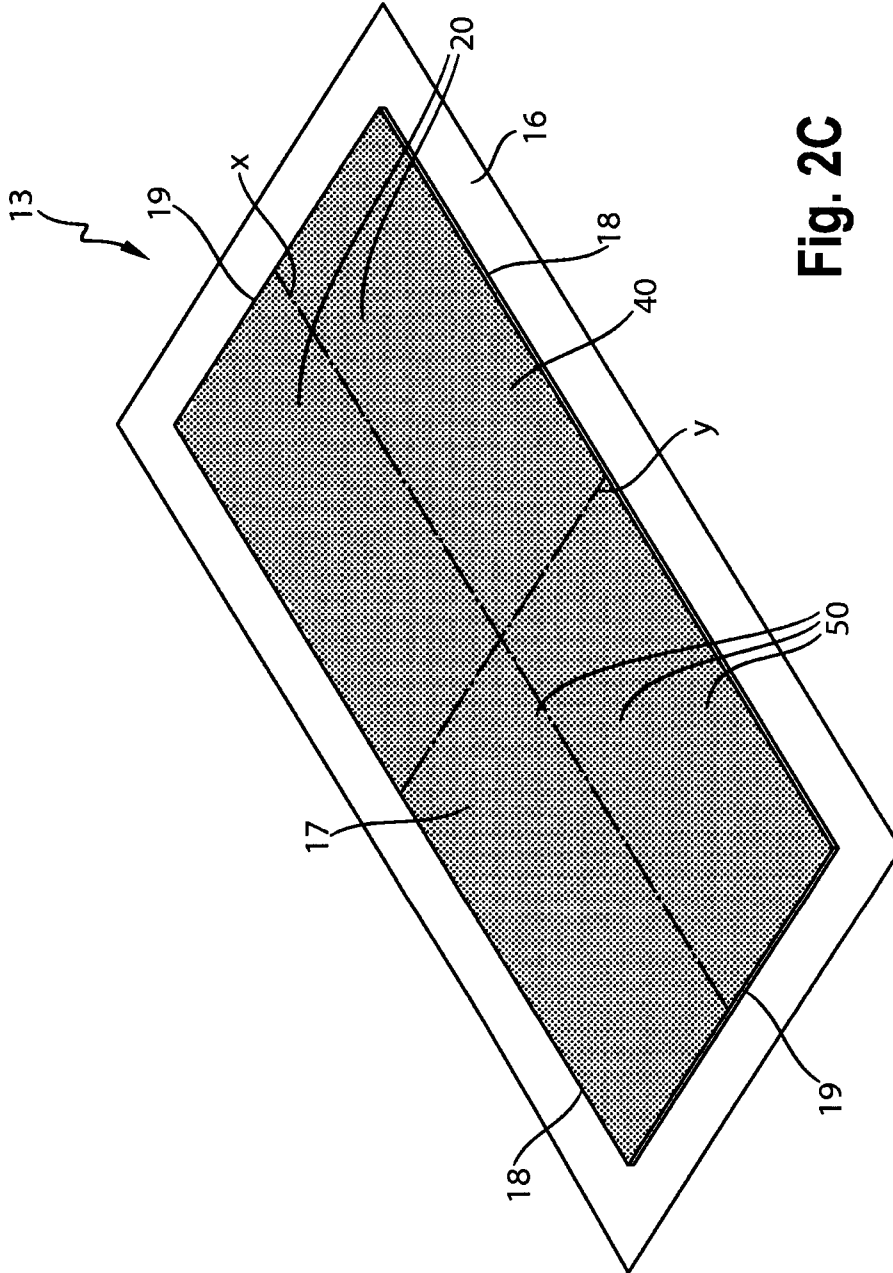

Fig. 2C

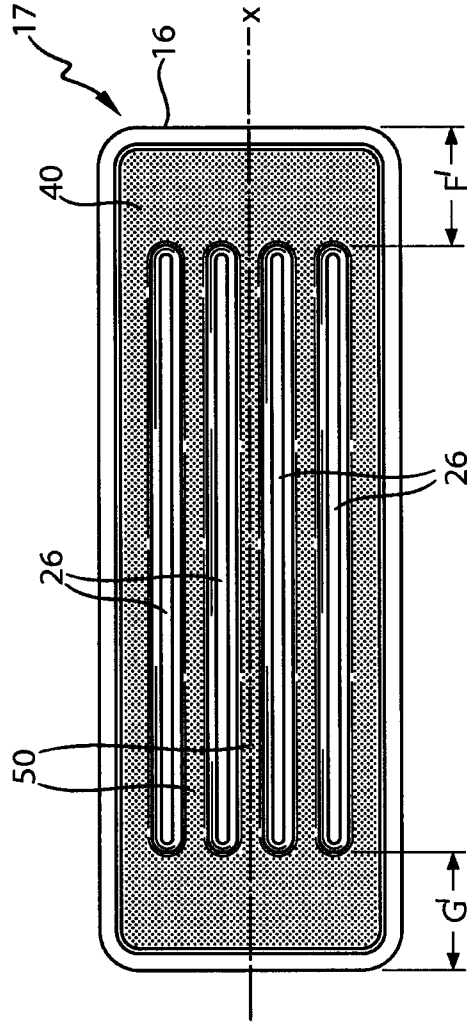

Fig. 3B

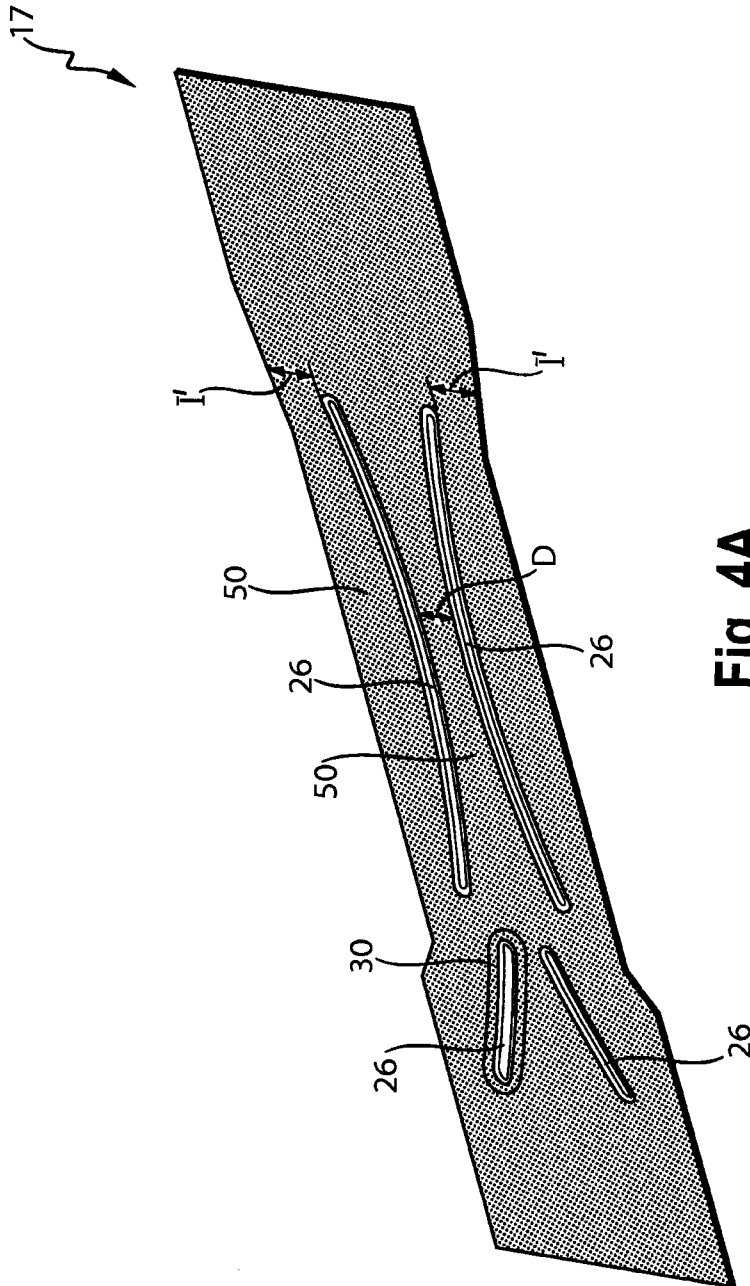

Fig. 4A

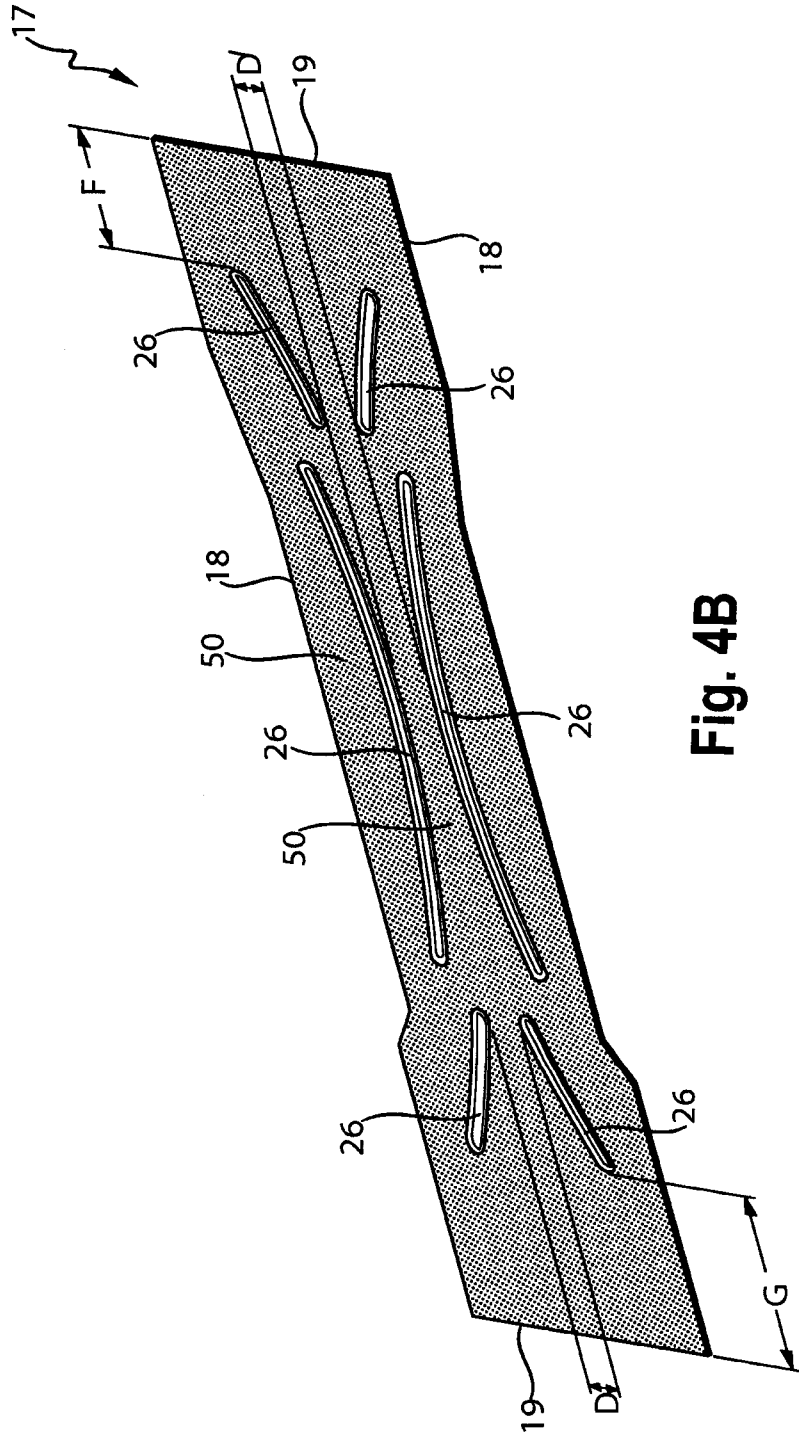

Fig. 4B

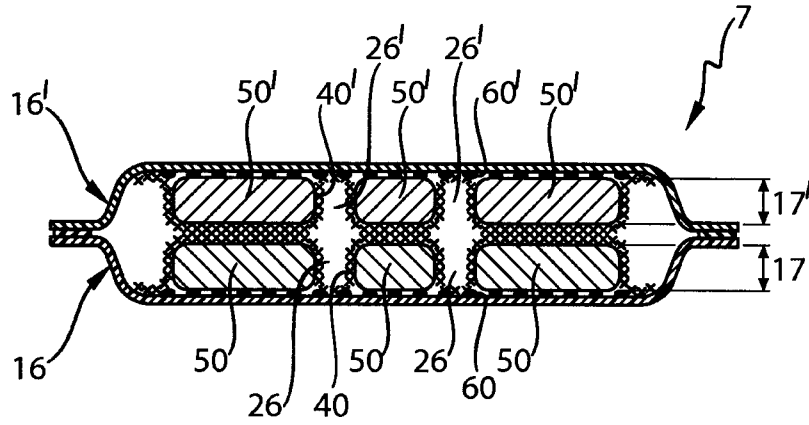

Fig. 5

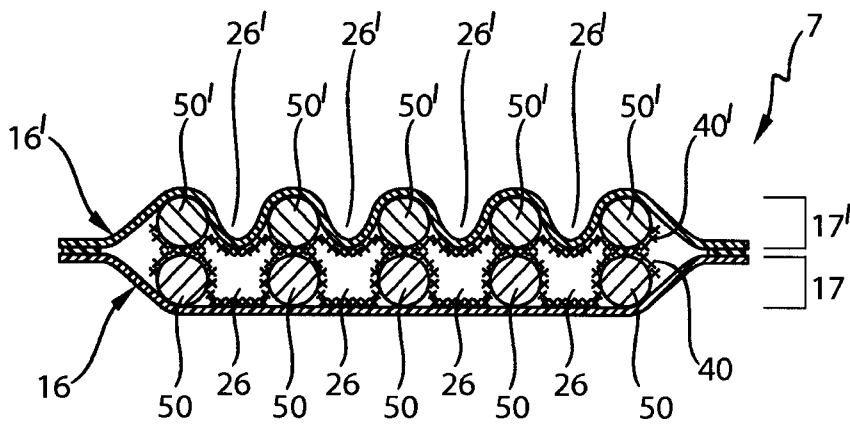

Fig. 6

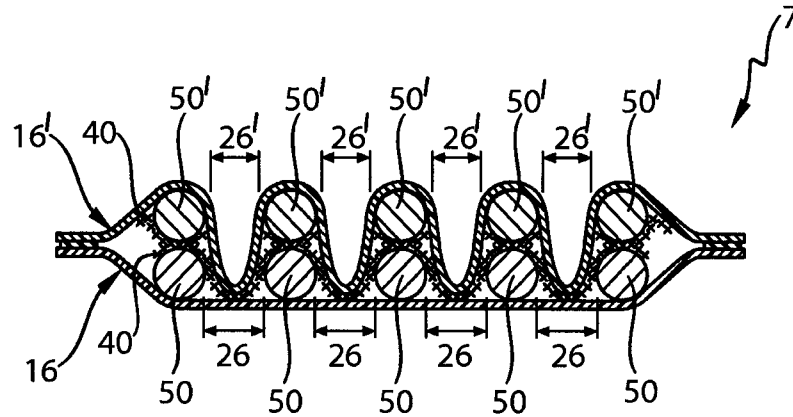

Fig. 7

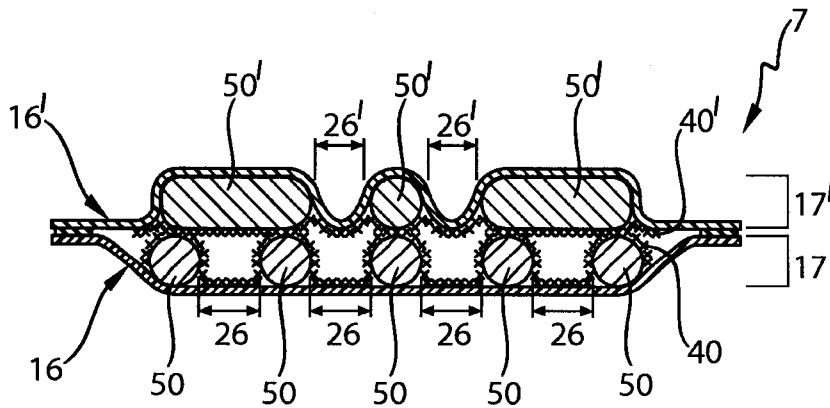

Fig. 8

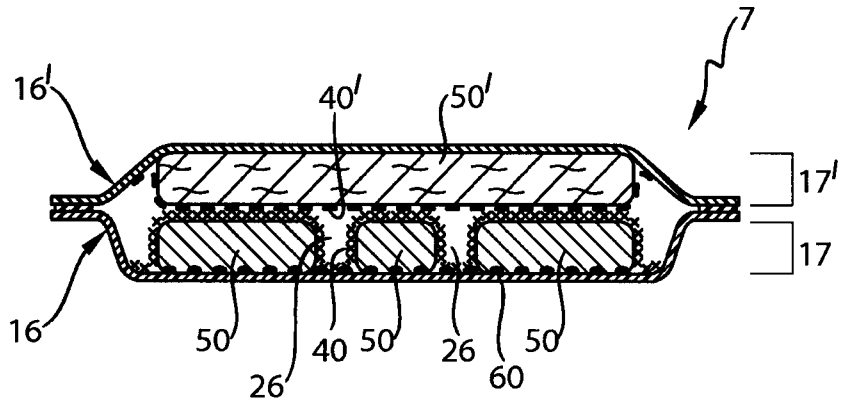

Fig. 9

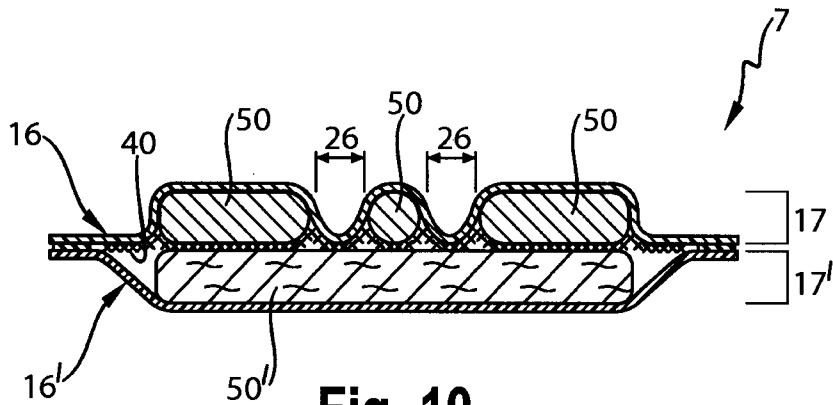

Fig. 10

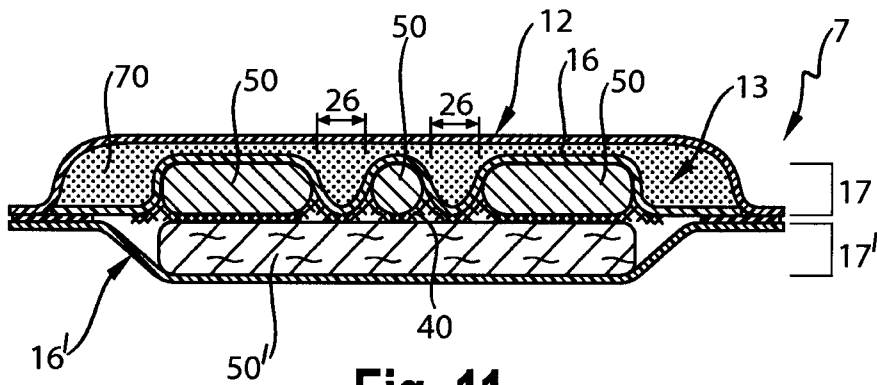

Fig. 11

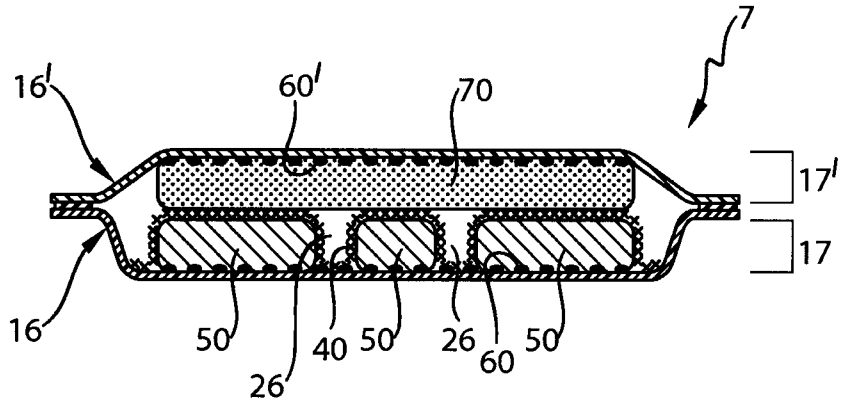

Fig. 12

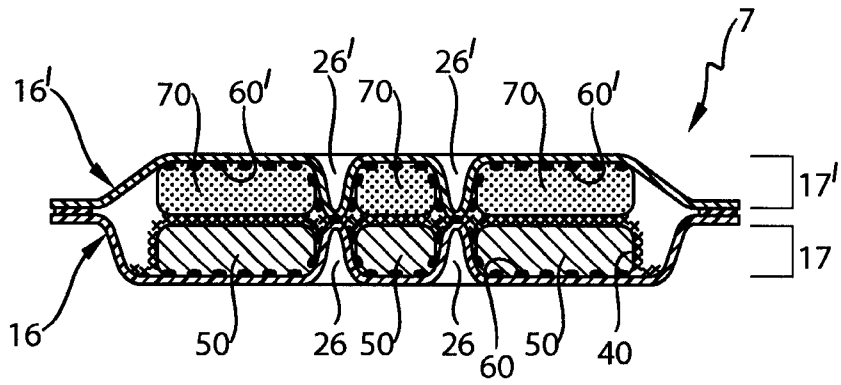

Fig. 13

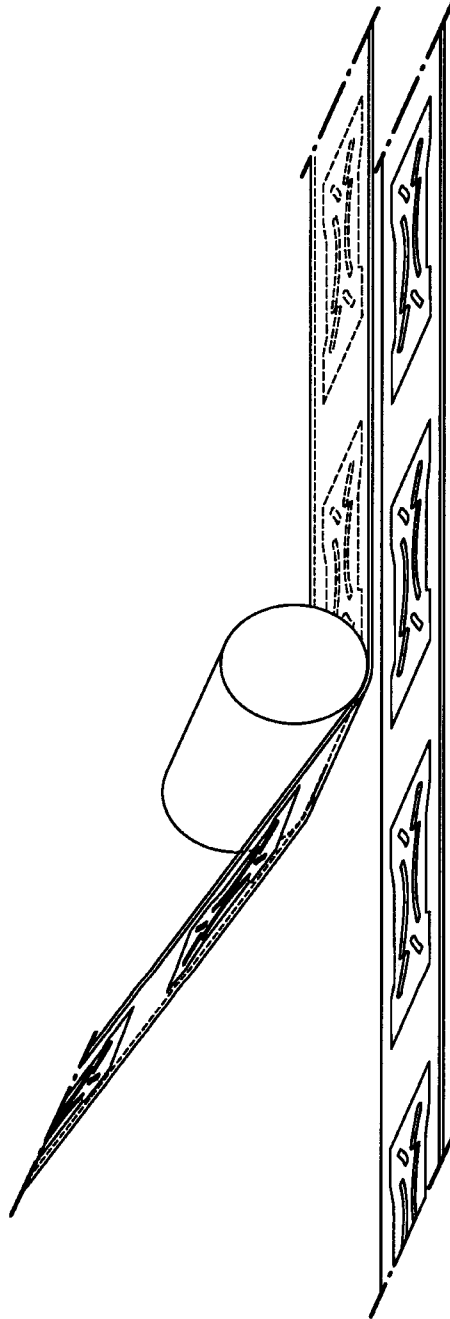

Fig. 14

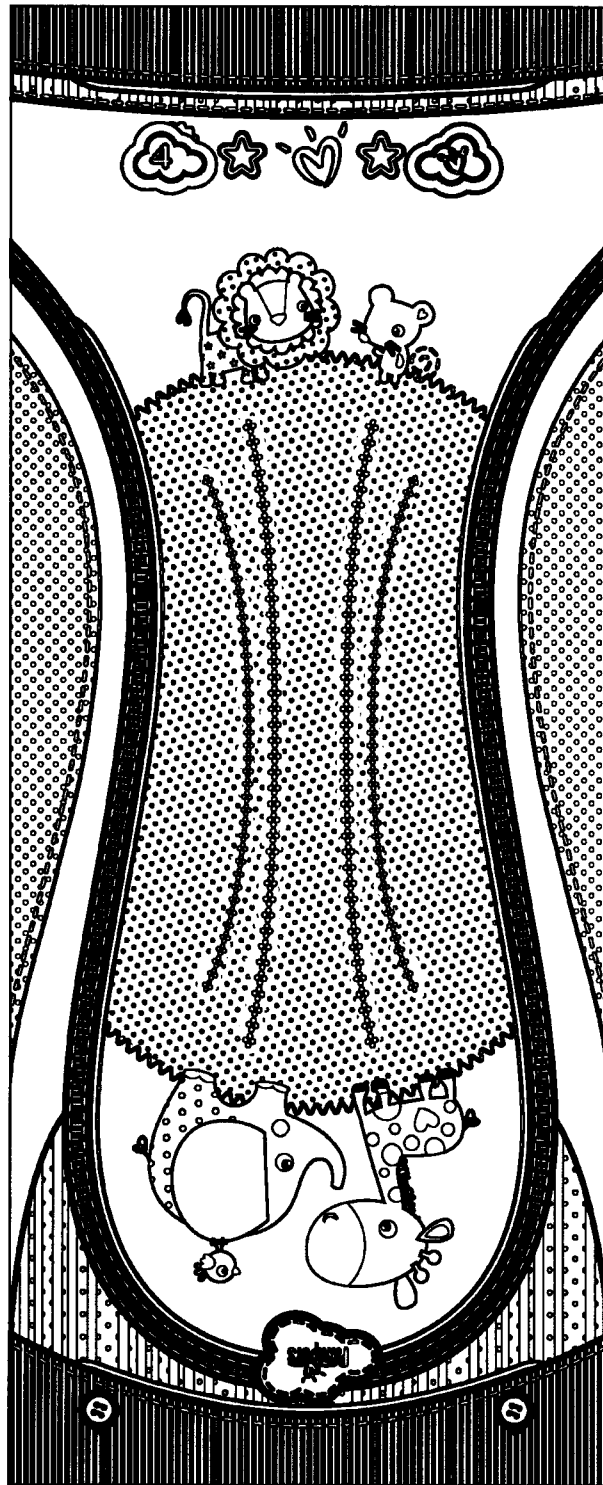

Fig. 15

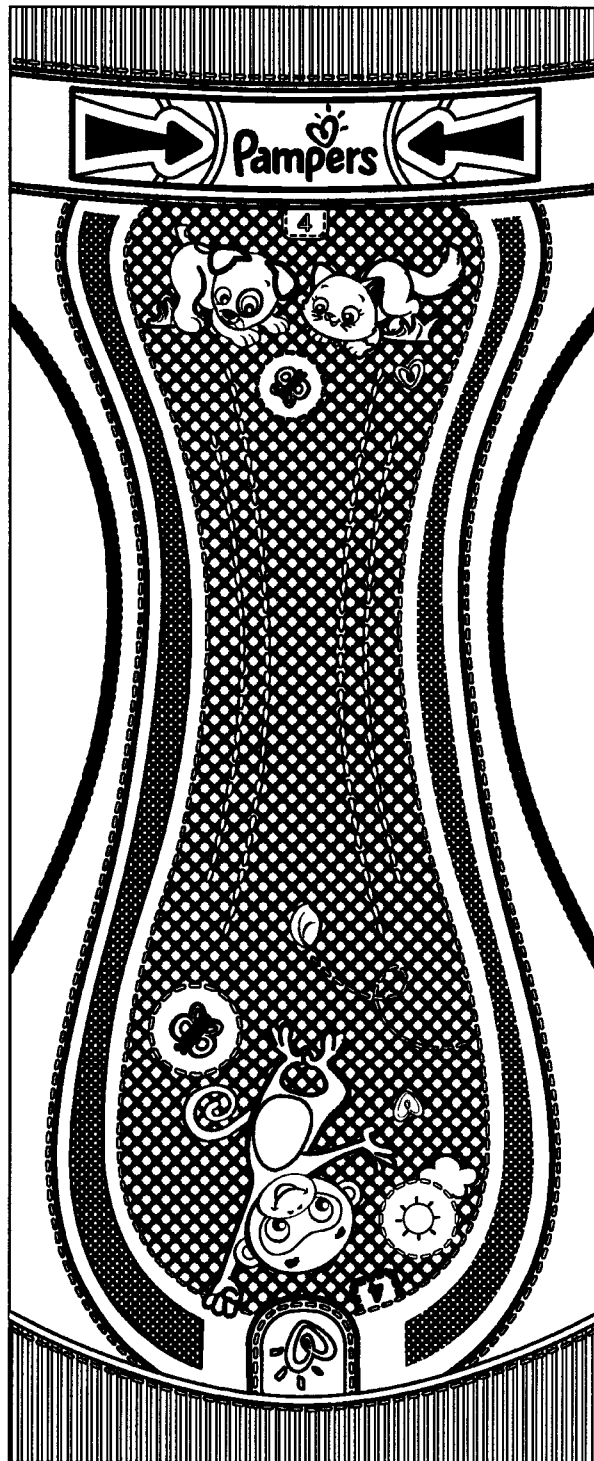

Fig. 16

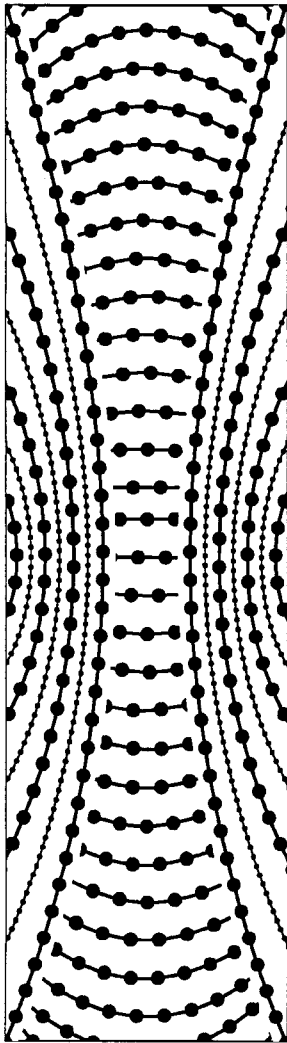

Fig. 17A

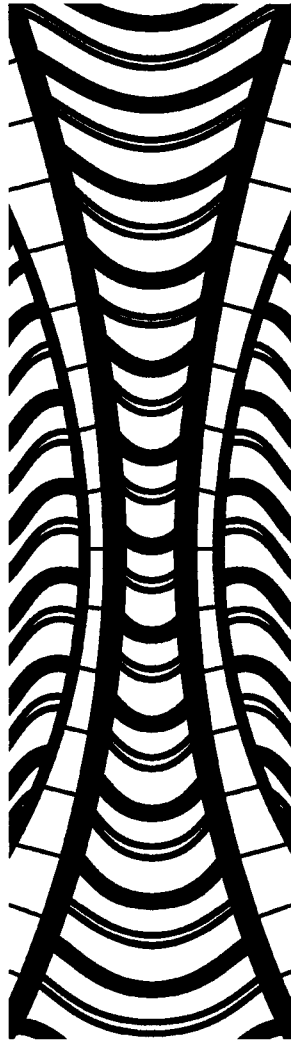

Fig. 17B

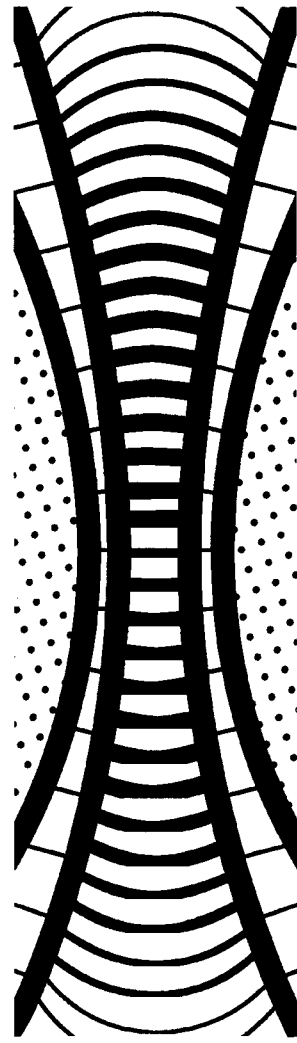

Fig. 17C

17/18

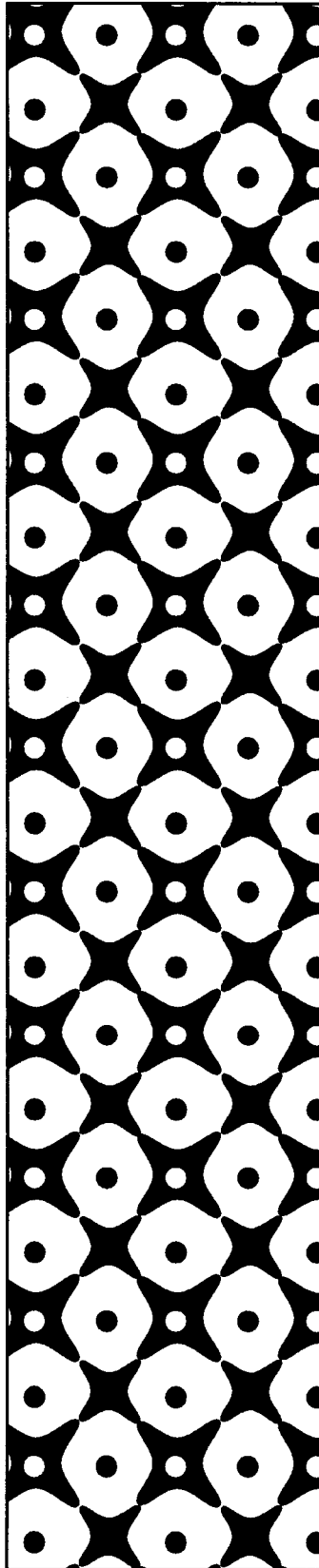

Fig. 18

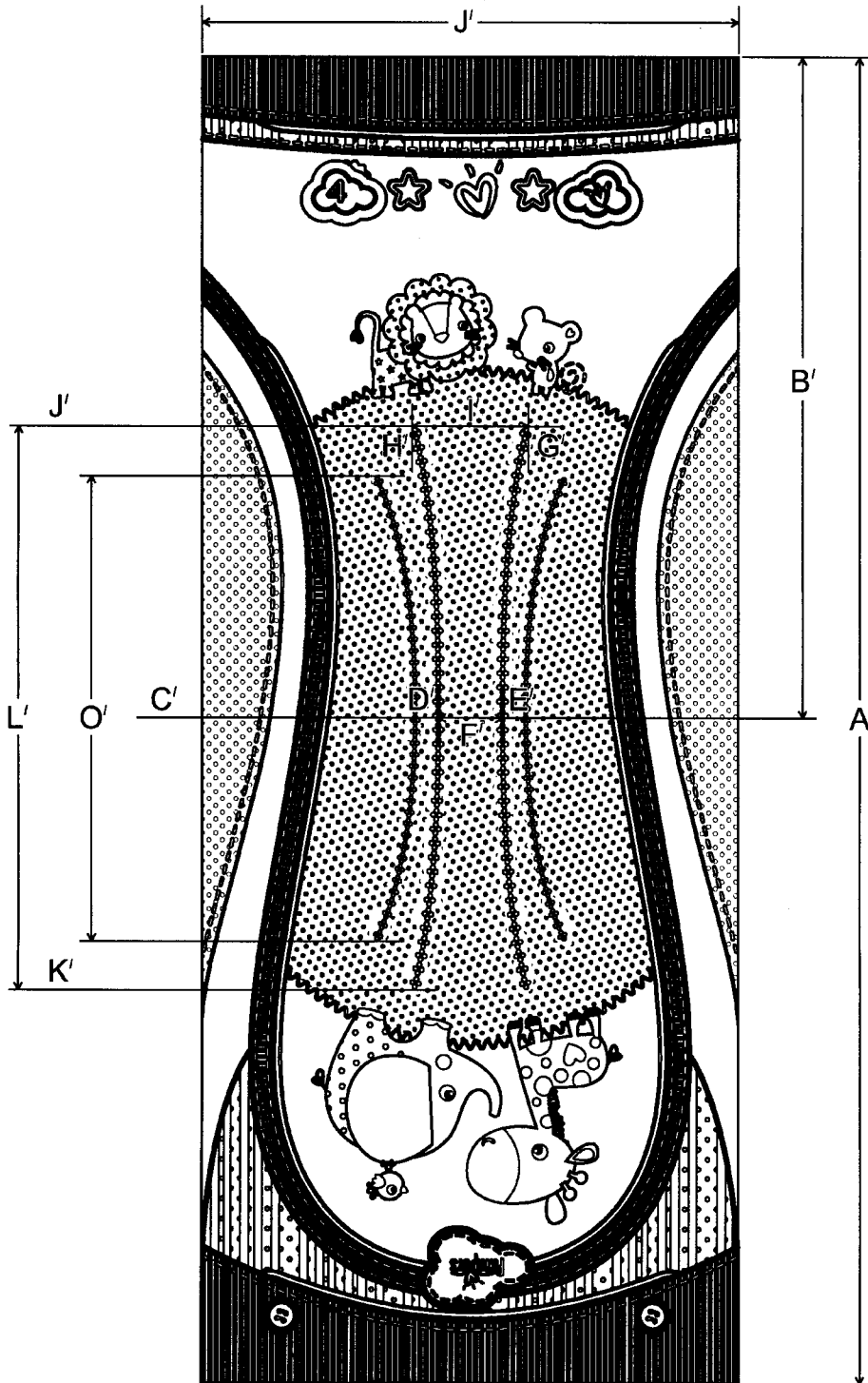

Fig. 19

