

(No Model.)

C. J. PHILLIPS.
HAND STRAP FOR STREET CARS.

No. 459,256.

Patented Sept. 8, 1891.

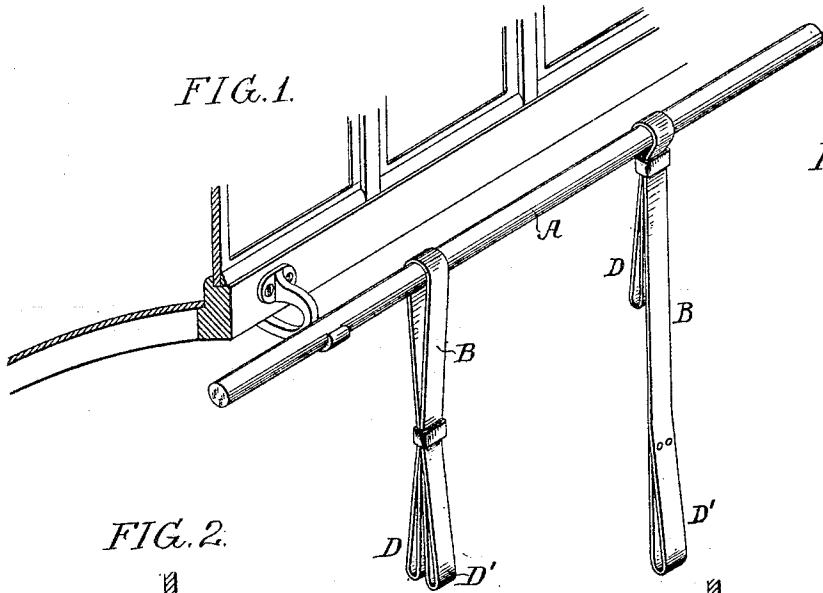

FIG. 1.

FIG. 6.

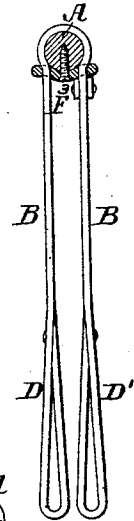

FIG. 2.

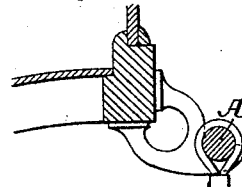
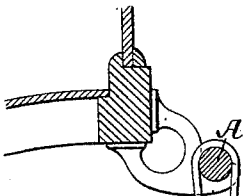

FIG. 5.

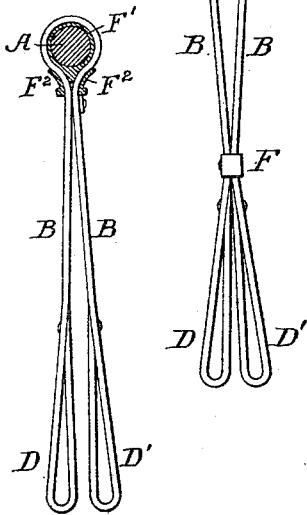

FIG. 4.

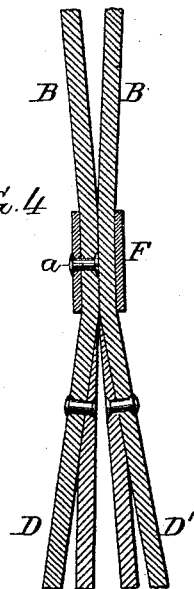

FIG. 3.

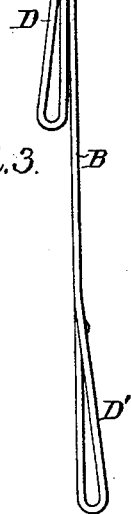
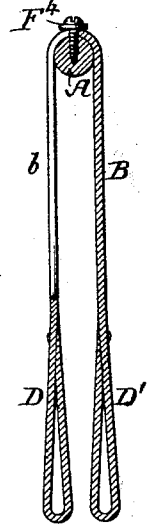

FIG. 7.



Witnesses:

Hamilton D. Turner.
R. Schleicher.

Inventor
Camillus J. Phillips
by his Attorneys
Houston & Houston

UNITED STATES PATENT OFFICE.

CAMILLUS J. PHILLIPS, OF PHILADELPHIA, PENNSYLVANIA.

HAND-STRAP FOR STREET-CARS.

SPECIFICATION forming part of Letters Patent No. 459,256, dated September 8, 1891.

Application filed June 13, 1891. Serial No. 396,123. (No model.)

To all whom it may concern:

Be it known that I, CAMILLUS J. PHILLIPS, a citizen of the United States, and a resident of Philadelphia, Pennsylvania, have invented certain Improvements in Extensible Hanger-Straps for Street-Cars, &c., of which the following is a specification.

The object of my invention is to provide a simple form of extensible-strap for street-cars and omnibuses, so that the strap can be drawn down within convenient reach of a short passenger or can be shortened to its normal length for passengers of average height. This object I attain in the manner hereinafter set forth, reference being had to the accompanying drawing, in which—

Figure 1 is a perspective view of part of a street-car and its strap-rail with two straps thereon, one of said straps being shortened and the other extended. Fig. 2 is a sectional view showing an end elevation of the shortened strap. Fig. 3 is a similar view showing the extended strap. Fig. 4 is an enlarged section of part of one of the straps; and Figs. 5, 6, and 7 are views illustrating modifications of the invention.

The present straps used in street-cars are objectionable for the reason that they are designed for persons of average height and are practically out of the reach of short passengers, or require such stretching of the arm as to be uncomfortable. Attempts have been made to overcome this objection by providing the straps with hand-holds mounted upon springs, so that they could be drawn down beyond the normal position; but these are expensive and liable to get out of order.

In carrying out my invention, therefore, I use a folded strap having a hand-hold at each end, this strap being suspended from the strap-rail but being free to slip over the same, so that one depending portion of the strap can be drawn down as the other rises, suitable stops preventing excessive movement or detaching of the strap from the rail. Thus, as shown in Figs. 1 to 3, A represents the strap-rail and B a strap looped over the same and having at one of its lower ends a hand-hold D and at the other end a hand-hold D', that portion of the strap which has the hand-hold D having secured to it by means of a rivet *a* or otherwise, at a point just above the hold-

hold, a loop F, through which the other portion of the strap passes and is free to slide. When the strap is in its normal condition, as shown in Fig. 2, both hand-holds are in line and can be conveniently grasped by a person of average height, or if the hand-hold D is grasped the strap will not lengthen, owing to the bearing of the loop F against the upper end of the hand-hold D'; but if the latter hand-hold is grasped it can be pulled down, as shown in Fig. 3 and at the right-hand side of Fig. 1, so as to be within easy reach of a person of less than average height, the strap slipping over the strap-rail and the hand-hold D and its loop rising until said loop is immediately beneath the strap-rail, as shown. The strap can be readily restored to its shortened or normal condition by pulling upon the hand-hold D until the loop comes in contact with the hand-hold D'.

Although it is preferred that the guide and stop-loop should be secured to one portion of the strap, this is not absolutely essential, as a ring F', free to slide on the strap-rail and having guide-loops F² for the strap, might be used—as shown, for instance, in Fig. 5—or a looped plate might be secured directly to the strap-rail, as shown at F³ in Fig. 6, or the loop may be dispensed with altogether as a stopping or guiding device, if desired. For instance, in Fig. 7 I have shown a stop and guide for the strap, consisting of a screw-pin F⁴, applied to the strap-rail and adapted to a longitudinal slot *b* in the strap. The constructions shown in Figs. 6 and 7, however, are open to the objection that they do not permit the strap to be moved longitudinally on the strap-rail, an objection which does not apply to the constructions shown in Figs. 1 to 5.

Although I have shown my invention as applied to a strap having hand-holds formed by looping the strap itself, it will be evident that the invention is equally applicable to that class of straps which have metallic handles at their lower ends.

Having thus described my invention, I claim and desire to secure by Letters Patent—

1. The combination of the strap free to slip over the strap-rail and having a hand-hold at each of its lower ends, with a stop and guide for said strap, substantially as specified.

2. The combination of the strap free to slip

over the strap-rail and having a hand-hold at each of its lower ends, and a loop serving as a guide and stop for the strap, substantially as specified.

5 3. The combination of the strap free to slip over and to move longitudinally on the strap-rail and having a hand-hold at each of its depending ends, with a stop and guide-loop
10 free to move with the strap in the movements of the latter along the strap-rail, substantially as specified.

4. The combination of the strap free to slip

over the strap-rail and having a hand-hold at each of its lower ends, with a loop carried by one portion of the strap and serving as a guide 15 through which the other portion of the strap is free to slide, substantially as specified.

In testimony whereof I have signed my name to this specification, in the presence of two subscribing witnesses.

CAMILLUS J. PHILLIPS.

Witnesses:

J. E. PHILLIPS,
HARRY SMITH.