



(22) Date de dépôt/Filing Date: 1998/03/13

(41) Mise à la disp. pub./Open to Public Insp.: 1999/09/13

(45) Date de délivrance/Issue Date: 2006/06/27

(51) Cl.Int./Int.Cl. *E04H 1/12* (2006.01),
E04H 9/14 (2006.01), *E04B 1/32* (2006.01)

(72) Inventeur/Inventor:
SOEHN, PETER, CA

(73) Propriétaire/Owner:
LALONDE, LARRY A., CA

(74) Agent: EDWARDS, ANTONY C.

(54) Titre : REFUGES DU NOUVEL AGE

(54) Title: NEW AGE SHELTERS

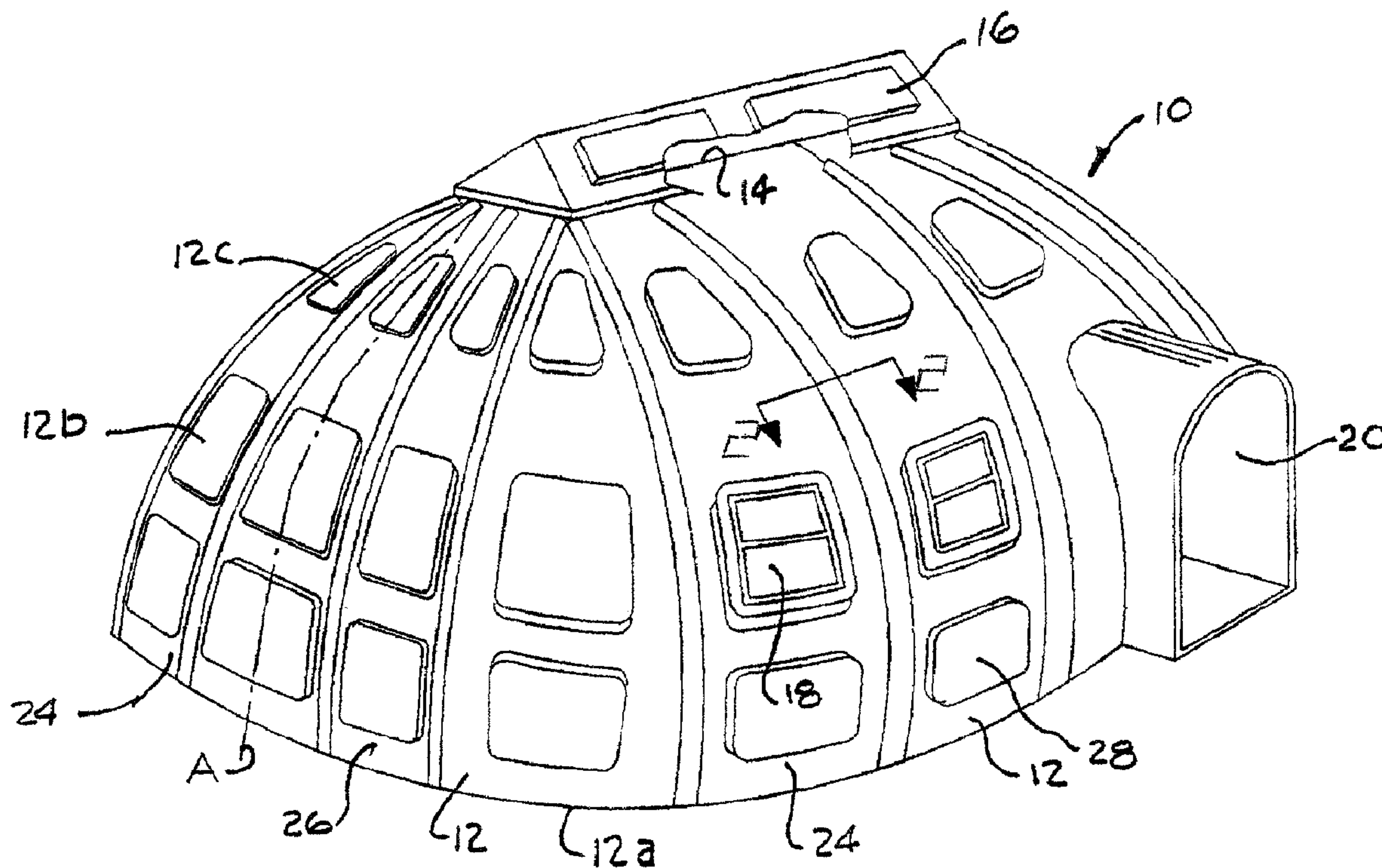

(57) Abrégé/Abstract:

A modular component shelter includes an adjacent side-by-side array of curved, interlocking, rigid panels. The panels curve upwardly and inwardly to a common vertex from a common base-level circumferential rim. The panels interlock between adjacent panels by means of raised interlocking ribs. The ribs extending in generally vertical planes along opposite side edges of each panel so as to form a first channel along a first side edge of each panel and second channel along an opposite second side edge of each panel. The first channel is shaped to snugly fit within the second channel along the length thereof. The first channel is releasably securable in the second channel.

Abstract of the Disclosure

A modular component shelter includes an adjacent side-by-side array of curved, interlocking, rigid panels. The panels curve upwardly and inwardly to a common vertex from
5 a common base-level circumferential rim. The panels interlock between adjacent panels by means of raised interlocking ribs. The ribs extending in generally vertical planes along opposite side edges of each panel so as to form a first channel along a first side edge of each panel and second channel along an opposite second side edge of each panel. The first channel is shaped to snugly fit within the second channel along the length thereof. The first channel is
10 releasably securable in the second channel.

NEW AGE SHELTERS

Field of the Invention

5 This invention relates to a locking application for connecting molded panels to form a prefabricated, portable and expandable structure.

Background of the Invention

10 Most buildings for use in residential, commercial, industrial or agricultural purposes, are not environmentally friendly and are costly to build. They require skilled trades and extensive time to erect. They are usually neither portable nor expandable and are unable to withstand high winds, earthquakes or heavy snow loads.

15 In the prior art, applicant is aware of United states Patent No. 5,513,471 and Canadian Patent No. 2,103,103 which are corresponding patents issued to Worms et al. and which describe a contiguous wall panel section which is formed in three planar portions; namely a vertical lower portion, a relatively gently inwardly sloping intermediate portion and a more aggressive inwardly sloping upper portion. The wall panels are formed with parallel
20 longitudinal sides, each of which has an integrally formed rib or channel and into which the channel of the corresponding side rib of successive wall panels are nested and secured. Corner panels are formed in the same way as the wall panels except that the vertical lower portion is curved in a horizontal plane. Two corner panels are utilized at a corner. The longitudinal sides of the lower section are parallel, while the outer sides of the intermediate and the upper
25 section sections of adjacent corner panels converge toward the top of the panel to match adjacent side wall panels.

Applicant is also aware of United States Patent No. 4,068,421, to Marovich in which is disclosed an integrally formed, smoothly curved wall panel which is formed as a

hemi-spheroidal section. The longitudinal edges of each panel has a channel which can be interfitted with the channel on adjacent panels which are then bolted together. Intermediate or wall panels having parallel longitudinal sides can be used to enlarge the structure to a generally ellipsoidal shape.

5

Summary of the Invention

It is the object of the present invention to provide a habitable shelter constructed from separate interlocking components or panels. The panels can be fabricated from a rigid, light weight material such as fiberglas or urethane, and embody both end wall and side wall panels. The end wall panels are spherical triangular segments. Side wall panels, having generally parallel longitudinal edges, may also be provided which can be utilized to lengthen the shelter.

Thus the present invention provides a sturdy weather proof shelter suitable for habitation which is assembled from pre-made modular components. The components take the form of wall panels which are curved inwardly and upwardly from a common base-level rim to a common vertex. The vertex is generally enclosed by a roof cap which provides a weatherproof cover. Each panel can be securely interlocked to the adjacent panel by means of raised ribs or channels which extend along the length of the panel in vertical planes adjacent and parallel to the longitudinal side edges of the panel.

A first channel is formed adjacent a first longitudinal side edge of the panel and a second channel is formed adjacent a second longitudinal side edge of the panel. First channels of each panel are formed so as to snugly fit within the second channels formed adjacent the second longitudinal side edge of panels when positioned in a side-by-side array. The channels are secured in an interlocked relationship by means of releasable fasteners such as bolts or the like.

Lateral displacement of the side-by-side array of panels is further inhibited by the formation of a first channel step formed along a first longitudinal side of the first channel and a first channel lip formed on a second longitudinal side of the first channel. The first channel lip protrudes laterally outwardly from the first channel. A corresponding second channel lip protrudes laterally outwardly from the first side of the second channel, and a raised auxiliary rib is formed parallel to and spaced from the opposite second edge of the second channel.

During assembly of these shelter components, the first longitudinal side edge of a panel is placed over a second longitudinal side edge of an adjacent panel in the side-by-side array so that the second channel is securely nested within the overlying first channel. Such positioning ensures that the second channel lip, adjacent the second channel, is placed in engagement beneath the first channel step, adjacent the first channel, and the first channel lip is snugly fitted in the depression formed between the second channel and the raised auxiliary rib. Releasable fasteners such as bolts can then be placed through aligned holes in the ribs.

In summary, the modular component shelter of the present invention includes an adjacent side-by-side array of curved, interlocking, rigid panels. The panels curve upwardly and inwardly to a common vertex from a common base-level circumferential rim. The panels interlock between adjacent panels by means of raised interlocking ribs. The ribs extend in generally vertical planes along opposite side edges of each panel so as to form a first channel along a first side edge of each panel and second channel along an opposite second side edge of each panel. The first channel is shaped to snugly fit within the second channel along the length of the channels. The first channel is releasably securable in the second channel by means of releasable fasteners such as bolts.

In the modular shelter of the present invention the panels include at least one curved array of end panels, the array of end panels in adjacent side-by-side array forming a rounded first end cap of the shelter. The end cap is formed as a generally spherical triangle.

The modular shelter further includes a second end cap, identical to the first end cap, the first and second end caps in opposed facing relation.

5 The first and second end caps may be mounted to each other. Intermediate panels may be mounted in parallel array in adjacent side-by-side array between the first and second end caps so as to form an elongate shelter.

10 In the modular shelter of the present invention the first channel further includes a step formed along a first edge of the first channel and a first channel lip formed along, so as to protrude outwardly of, an opposite second edge of the first channel. The second channel further includes a second channel lip formed along, so as to protrude outwardly of, a first edge of the second channel. A raised auxiliary rib is parallel to and spaced from an opposite second edge of the second channel. When the second channel of one of the panels is interlocked within the first channel of an adjacent panel in the adjacent side-by-side array, by snug fitment
15 of the first channel over the second channel, the second channel lip mates snugly under the step and the first channel lip fits snugly between the second edge of the second channel and the auxiliary rib. A roof cap may be mounted over the common vertex. One of the intermediate panels may have a door portal formed therein.

20 Brief Description of the Drawings

Figure 1 is a perspective view of the modular component shelter according to the present invention.

25 Figure 2 is an enlarged lateral cross-sectional view of the interlocking of two adjacent panels along line 2-2 of Figure 1.

Figure 3 is a lateral cross-sectional view through a typical panel in the shelter of Figure 1.

Detailed Description of Preferred Embodiments

The modular component shelter 10 of the present invention consists of a plurality of light weight and rigid interlocking panels 12 which may be formed of fibreglass or urethane. Modular interlocking panels 12 are curved along the longitudinal axis A from a common base-level rim 12a to provide a substantially vertical wall portion 12b and an upward and inwardly sloping roof portion 12c. Roof portion 12c terminates at a common vertex 14. A roof cap 16 is secured to panels 12 adjacent common vertex 14 to provided a weather seal. Panels 12 may be provided with windows 18 and a door portal 20.

End panels 24 are arcuately formed in a horizontal plane adjacent the base-level rim 12a, so that a side-by side array of panels 24 will create a rounded end portion 26 of shelter 10. End panels 24 are spherically triangular in shape and have side edges which converge toward the apex. A plurality of end panels 24 secured in a side-by-side array will form the rounded end portion 26 for shelter 10

The panels have first and second longitudinal side edges 30 and 32 respectively. Longitudinal side edges 30 and 32 are in vertical planes once the panels have been erected and interlocked in the manner set out below. A first channel 34 is formed adjacent to first longitudinal side edge 30 of the panel and a second channel 36 is formed adjacent to second longitudinal side edge 32 of the panel. First channel 34 is slightly larger than channel 36 so that when first longitudinal side edge 30 overlaps second longitudinal side edge 32, in a vertical side-by-side array of panels, second channel 36 will fit snugly within first channel 34.

Projecting laterally outward from first channel 34 is a first channel lip 40. Formed parallel to and spaced inwardly from first channel 34 is a first channel step 46. A second channel lip 44 protrudes laterally outwardly from second channel 36. Positioned inwardly and parallel to second channel 36 is a raised auxiliary rib 42 forming a depression 43

therebetween. Both first channel step 46 and raised auxiliary rib 42 are spaced inwardly from their respective channels by a distance equal or slightly greater than the lateral width of the channel lips 40 and 44 respectively, i.e. the lateral distance that raised auxiliary rib 42 is spaced laterally inwardly from channel 36, that is, the lateral dimension of depression 43, matches the lateral width of first channel lip 40. The lateral distance that first channel step 46 extends laterally inwardly from first channel 34 matches the lateral width of second channel lip 44. This feature provides a positive positioning device which interlocks the panel edges. The contact between the panel edges and the adjacent shoulders created by the raised auxiliary rib 42 and channel step 46 inhibits lateral dislocation between the nested edges. Releasable fasteners such as bolts 54 may be placed through aligned holes in the ribs to secure the panels together.

Second channel lip 44, and step 46 are offset from the body 38 of the panel by a distance B which is generally equal to the thickness of the panel. Such offset distance B permits the inside face 50 of adjacent panels to be kept in planar alignment when the second longitudinal side edge 32 of the panel is overlapped by first longitudinal side edge 30 of an adjacent panel when positioned in an overlapping side-by-side array.

As will be apparent to those skilled in the art in the light of the foregoing disclosure, many alterations and modifications are possible in the practice of this invention without departing from the spirit or scope thereof. Accordingly, the scope of the invention is to be construed in accordance with the substance defined by the following claims.

WHAT IS CLAIMED IS:

1. A modular component shelter comprising:
 - 5 an adjacent side-by-side array of curved, interlocking, rigid panels,
said panels curving upwardly and inwardly to a common vertex from a common base-level circumferential rim,
 - 10 said panels interlocking between adjacent panels by means of raised interlocking ribs, said ribs extending in vertical planes along opposite side edges of each panel so as to form a first channel along a first side edge of each panel and second channel along an opposite second side edge of each panel,
 - 15 said first channel of a first panel of said panels shaped to snugly fit over said second channel of an adjacent second panel of said panels along the length of said first and second channels, said first and second channels releasably mountable to each other by means of releasable fasteners,
 - 20 wherein said each panel further comprises a step formed along a first longitudinal edge of said first channel, said step protruding laterally outwardly from said first longitudinal edge of said first channel, and wherein said each panel further comprises a first channel lip formed along a second longitudinal edge of said first channel, said second longitudinal edge opposite and parallel to said first longitudinal edge of said
25 first channel, said first channel lip protruding laterally outwardly from said second longitudinal edge of said first channel, said step and said first channel lip co-planar in a first plane and extending oppositely from, respectively, said first and second longitudinal edges of said first channel when viewed in lateral cross-section,

and wherein said each panel further comprises a second channel lip formed along a first longitudinal edge of said second channel, said second channel lip protruding laterally outwardly from said first longitudinal edge of said second channel, and wherein said each panel further comprises a raised auxiliary rib parallel to and laterally spaced apart from a second longitudinal edge of said second channel, said second longitudinal edge of said second channel opposite and parallel to said first longitudinal edge of said second channel,

said second channel and said auxiliary rib raised out of a second plane containing said first and second longitudinal edges of said second channel when viewed in lateral cross section so as to form a depression between said second longitudinal edge of said second channel and said auxiliary rib, said depression sized to snugly receive, in said depression, said first channel lip when said first channel is mounted over said second channel, said second channel lip and said depression co-planar in said second plane and extending oppositely from, respectively, said first and second longitudinal edges of said second channel when viewed in lateral cross-section,

wherein when said second channel of one of said panels is interlocked within said first channel of an adjacent panel in said adjacent side-by-side array, by snug fitment of said first channel over said second channel, said second channel lip mates snugly under said step and said first channel lip fits snugly in said depression, between said second longitudinal edge of said second channel and said auxiliary rib.

2. The modular shelter of claim 1 wherein said panels comprise at least one curved array of end panels, said array of end panels in said adjacent side-by-side array forming a rounded first end cap of said shelter.
3. The modular shelter of claim 2 wherein array of end panels is an array of spherical triangles forming said first end cap.

4. The modular shelter of claim 2 further comprising a second end cap, identical to said first end cap, said first and second end caps in opposed facing relation.
- 5 5. The modular shelter of claim 4 wherein said first and second end caps each collectively form a spherical triangle.
6. The modular shelter of claim 4 wherein said first and second end caps are mounted to each other.
- 10 7. The modular shelter of claim 4 wherein intermediate panels are mounted in parallel array in said adjacent side-by-side array between said first and second end caps so as to form an elongate shelter.
- 15 8. The modular shelter of claim 1 wherein said releasable fasteners are bolts.
9. The modular shelter of claim 1 further comprising a roof cap mounted over said common vertex.
- 20 10. The modular shelter of claim 7 wherein one of said intermediate panels has a door portal formed therein.

