

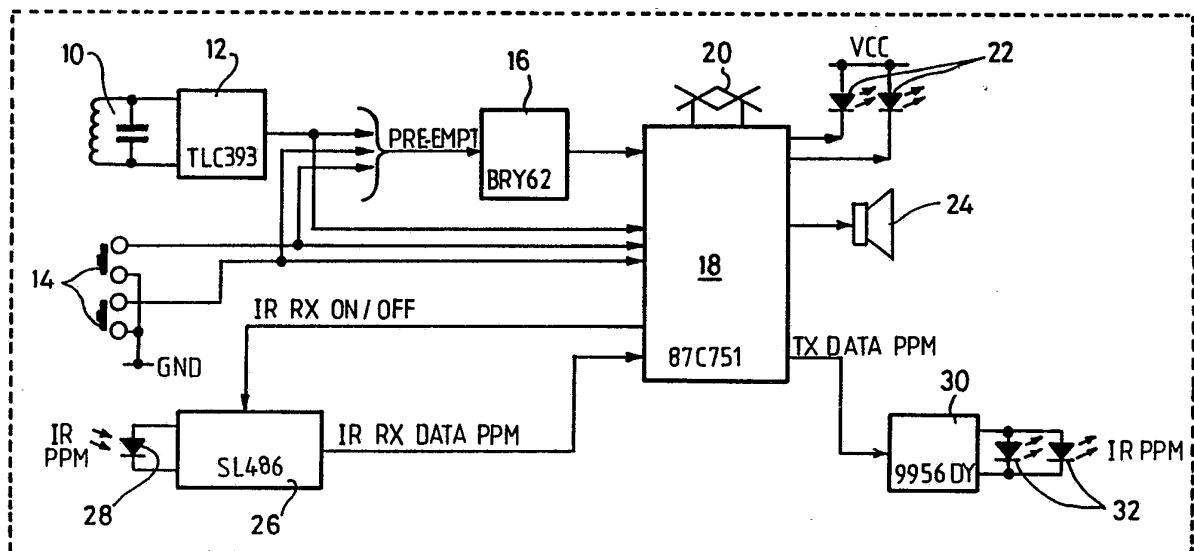

## INTERNATIONAL APPLICATION PUBLISHED UNDER THE PATENT COOPERATION TREATY (PCT)

<p>(51) International Patent Classification <sup>5</sup> : <b>G06K 7/00, 7/10, G07C 9/00</b></p>	<p><b>A1</b></p>	<p>(11) International Publication Number: <b>WO 93/18476</b> (43) International Publication Date: 16 September 1993 (16.09.93)</p>
<p>(21) International Application Number: PCT/GB93/00476 (22) International Filing Date: 8 March 1993 (08.03.93) (30) Priority data: 9205269.5 11 March 1992 (11.03.92) GB (71) Applicant (for all designated States except US): OLIVETTI RESEARCH LIMITED [GB/GB]; Old Addenbrookes Site, 24A Trumpington Street, Cambridge CB2 1QA (GB). (72) Inventors; and (75) Inventors/Applicants (for US only) : HOPPER, Andrew [GB/GB]; Sainsfoins, Whittlesford Road, Little Shelford, Cambridgeshire CB2 5EU (GB). HARTER, Andrew [GB/GB]; 16 Hawthorn Road, Cambridge, Cambridgeshire CB4 1AX (GB). BLACKIE, Thomas, Dalgleish [GB/GB]; 386 Wisden Road, Stevenage, Hertfordshire SG1 5JH (GB).</p>		<p>(74) Agent: NASH, Keith, Wilfrid; Keith W. Nash &amp; Co., Pearl Assurance House, 90-92 Regent Street, Cambridge CB2 1DP (GB). (81) Designated States: AT, AU, BB, BG, BR, CA, CH, CZ, DE, DK, ES, FI, HU, JP, KP, KR, LK, LU, MG, MN, MW, NL, NO, NZ, PL, PT, RO, RU, SD, SE, SK, UA, US, European patent (AT, BE, CH, DE, DK, ES, FR, GB, GR, IE, IT, LU, MC, NL, PT, SE), OAPI patent (BF, BJ, CF, CG, CI, CM, GA, GN, ML, MR, SN, TD, TG).  Published With international search report.</p>

(54) Title: TRACKING AND/OR IDENTIFICATION SYSTEM



## (57) Abstract

A tracking and identification system comprises a plurality of active badges carried by carriers, which may be humans and/or animals and/or objects within a predetermined area, together with a plurality of transceiver sensor stations within the area and in communication with a master control centre. Each badge has an IR transmitter (30) for transmitting a unique IR identification signal, and an astable oscillator (16) which, via a microprocessor (18), causes the IR identification signal to be spontaneously transmitted on a periodic basis, for example every 10 seconds. Additionally, by means of push buttons (14), the IR identification signal can be transmitted by a user prompt, and, by means of an RF field detector (12), the IR identification signal can be transmitted due to entry of the badge into the RF field of an RF field generator.

**FOR THE PURPOSES OF INFORMATION ONLY**

Codes used to identify States party to the PCT on the front pages of pamphlets publishing international applications under the PCT.

AT	Austria	FR	France	MR	Mauritania
AU	Australia	GA	Gabon	MW	Malawi
BB	Barbados	GB	United Kingdom	NL	Netherlands
BE	Belgium	GN	Guinea	NO	Norway
BF	Burkina Faso	GR	Greece	NZ	New Zealand
BG	Bulgaria	HU	Hungary	PL	Poland
BJ	Benin	IE	Ireland	PT	Portugal
BR	Brazil	IT	Italy	RO	Romania
CA	Canada	JP	Japan	RU	Russian Federation
CF	Central African Republic	KP	Democratic People's Republic of Korea	SD	Sudan
CG	Congo			SE	Sweden
CH	Switzerland	KR	Republic of Korea	SK	Slovak Republic
CI	Côte d'Ivoire	KZ	Kazakhstan	SN	Senegal
CM	Cameroon	LI	Liechtenstein	SU	Soviet Union
CS	Czechoslovakia	LK	Sri Lanka	TD	Chad
CZ	Czech Republic	LU	Luxembourg	TG	Togo
DE	Germany	MC	Monaco	UA	Ukraine
DK	Denmark	MG	Madagascar	US	United States of America
ES	Spain	ML	Mali	VN	Viet Nam
FI	Finland	MN	Mongolia		

- 1 -

Title    Tracking and/or Identification SystemField of the invention

This invention relates to a system for tracking and/or identifying carriers (which may be people or vehicles or animals or any movable object) within a predetermined area (which may be a building or site containing a multiplicity of buildings such as a military site or airfield or simply a land area of limited extent). The carrier carries a badge, hereinafter referred to as an active badge, which is able to transmit an identification signal to any of a plurality of transceivers distributed throughout the predetermined area, and which is also able to receive commands and data from the transceivers.

Background to the invention

A tracking and identification system based on infra-red (IR) transmission and reception is known from U.S. Patent No. 4837568. In this system the active badge includes an IR transceiver which can communicate with an IR interrogator which, in the system described, is carried by a moving security guard. The interrogator can communicate information to and receive information from a master control centre. The known system is, in the context of its proposed use, satisfactory as a security system patrolled by a guard, but it is not satisfactory for tracking or locating a carrier because the active badge has to be externally prompted to cause it to transmit its identification signal.

- 2 -

It is a primary object of this invention to provide an improved tracking and identification system, and more particularly to provide an improved active badge for use in such a system.

#### The invention

According to the invention, there is provided a tracking and identification system which comprises a plurality of active badges carried by a plurality of carriers within a predetermined area, each badge having an IR transmitter circuit for transmitting a unique IR identification signal, and a plurality of transceiver sensor stations in the predetermined area able to communicate both with the active badges and with a master control centre, wherein each active badge is arranged spontaneously to transmit its identification signal periodically, and able to transmit its identification signal on the occurrence of an external prompt.

Preferably, the active badges normally reside in a power driven sleep condition mode and incorporate means such as a relaxation oscillator which times out on a periodic basis, for example approximately every 10 seconds, to wake the badge and thereby cause it to transmit the IR identification signal. The timing out period is preferably adjustable and set to be slightly different for each of the active badges in the system, thereby to achieve a randomness of IR transmission.

The awake mode of each of the active badges may also be brought about by operation of one or more switching devices, preferably pushbutton switches, on the badge. Alternatively or additionally, the awake mode may be

- 3 -

brought about by entry of the carrier (and thereby the badge) into the RF field of an RF generating station of specific frequency and energy.

When the badge is woken up by an external stimulus as aforesaid, the badge transmits its IR identification data in combination with status information indicating which button was pressed and/or if the badge is in an RF field.

Preferably, before transmitting its IR identification signal, whether automatically or due to external stimulus, the badge listens, by means of an IR receiving circuit, to determine if any other IR signal is currently being transmitted in the predetermined area and, if it is, either reverts to its sleep condition mode or holds back the transmission for a later attempt. Potentially corrupting collisions between two simultaneous IR transmissions are thus avoided.

The identification data (ID number) in each badge is preferably held in the EPROM of a microprocessor within the badge. This ID number is preferably set during manufacture, and can be set to a 48 bit number (281 Terra combinations), thus providing for an effectively infinite number of active badges. This means that the system can be used, not only for tracking personnel, but for tracking virtually every movable object within the predetermined area. Thus, the control system can be employed for video indexing, for example to track and locate any of a virtually infinite number of items of goods within a trading organisation.

Since each active badge preferably incorporates a microprocessor as aforesaid, all packets of data exchanged

- 4 -

between a badge and a transceiver sensor station can have a checksum attached, to maintain data integrity.

Preferably, following an IR transmission by a badge, the receiver circuit in the badge is operative for a listening period, before reverting to its sleep condition mode. During this listening period, data and commands can be sent to the badge by IR transmission. For example, the badge may incorporate one or more indicators, such as LEDs, and/or a buzzer or speaker, which is or are operative responsively to paging commands sent to the badge. Information relating to the paging command, herein termed status information, is preferably stored in a RAM internal to the badge. Although the badge then reverts to its sleep mode condition, stored information in the RAM can preferably be retrieved by depression of one of the push buttons, again to activate the LED indicators or the speaker. By use of at least two LEDs and various combinations of tunes on the speaker, it is possible to indicate numerous categories and meanings of status information.

The RAM within the badge preferably has an allocated section where detailed information can be stored relating to the predetermined area to which a badge belongs, e.g. the company or organisation from which it comes. This information is herein termed home field data. This home field data is set via a "set home" command to the badge. As each badge within an organisation can be set with its home field data, the badge can be interrogated when in a remote organisation, using a "get home" command, and thus the system can find out where a badge has come from and where to ask for, or send information relating to the badge. By use of the home field facilities, the system

- 5 -

can be used to exchange information between cooperating sites, and thus a global badge tracking/location/paging system can be realised. Use of the home field alleviates the need for a large global database, which would be impractically slow to access, and impossible to maintain in a coherent state.

As well as sending paging information to a badge during the listening period, it is preferably also possible to send an IR interrogation command to authenticate the badge, and thereby the carrier, conveniently. Each badge may contain a unique 128 bit secret password, which is part of the code inserted in the badge during manufacture. A "challenge" signal passes a 48 bit random number to the badge, which accepts this random number, combines it with the 128 bit secret password and, using an encryption algorithm contained within the badge, calculates an encrypted reply. The reply signal is returned to the challenging transceiver unit, and is verified within the system. The badge can thus be used for a secure access control mechanism, such as at door entry points.

The RF field detector is preferably a passive tuned circuit within the active badge; the field detector responds to a set frequency of around a few hundred kHz; the precise frequency is set dependent on local regulations for the place where the system is to operate. An accompanying field generator may be set so that the RF energy transmitted is at a suitably low level so as to obtain exempt classification approval for the device.

Conveniently, the output of the field detector, when a carrier enters a relevant RF field, is used to wake the badge and cause an IR transmission, should the above

- 6 -

stated condition be met, i.e. no other IR signal being transmitted simultaneously. Before transmitting the IR identification packet, the output of the field detector is preferably monitored by the microprocessor. By modulating the field additional information can be passed to the badge. This additional information makes it possible for several RF fields or zones to be located within one elemental area (room), and for each of the fields to be uniquely identifiable by the active badge. Normally each of the RF fields is localised so that said fields do not overlap, possibly with a range of around 1 metre, and each of the fields is programmed with a unique code. Thus, when a badge enters a particular RF field it can detect which RF field it is, so that much finer granularity of location information can be transmitted.

Similarly, when multiple fields overlap the badge decodes the modulated information from each of the fields. Thus whilst located within several fields the badge can transmit its ID and the identification data relating to each of the fields that it has detected.

As well as being used to achieve more precise location information, the field detector may be used at critical locations, for example around doors, to stimulate the badge and thus cause it to wake up as the carrier approaches. There can thus be a near instantaneous IR communication exchange, rather than possibly having to wait up to 10 seconds for spontaneous transmission from the badge.

A preferred active badge comprises a microprocessor, IR transmitting diodes, an IR receiver, two LED indicators, a piezo-ceramic speaker, two pushbutton switches, a light

- 7 -

dependent resistor (LDR), a relaxation oscillator and an RF field detection circuit.

The LDR may be used to slow down the spontaneous activations of the active badge at night, if this is required.

A preferred sensor unit comprises two microprocessors, two FIFO buffer memories, an IR receiver, an IR transmitter and an interface with a 4-wire network via which the transceiver unit can communicate with the master control centre.

#### Description of embodiment

A practical example of tracking and identification system in accordance with the invention is now described with reference to the accompanying drawings, in which:-

Figure 1 is a block circuit diagram of an active badge;

Figure 2 is a block circuit diagram of a network sensor station;

Figure 3 is a block circuit diagram of an RF field generating/multi I/O station;

Figure 4 is a block circuit diagram of a workstation sensor station;

Figure 5 shows a typical layout of the tracking and identification system within a building; and

Figure 6 shows a typical layout of part of the system

- 8 -

within a single room of the building.

Referring to Figure 1, the principal components of an active badge for use in the system are as follows:

A passive tuned circuit 10 comprises one capacitor and one wire wound inductor. The resonant frequency of this circuit 10 corresponds to a frequency generated by an RF field generator circuit later described with reference to Figures 3 and 4;

A low current comparator 12 monitors the output of the tuned circuit 10, and which, in combination with the circuit 10, forms a field detector circuit. When a field of suitable frequency and strength is detected, the comparator output changes state;

Two pushbutton switches 14;

An astable relaxation oscillator 16, with an approximate 10 second time out which is variable from badge to badge. Included in the timing circuit is a light dependent resistor (LDR); this LDR varies the time out period with ambient light intensity. When it is very dark, e.g. at night, or when the badge is in a drawer, the badge oscillator times out infrequently; thus the badge power consumption is reduced, as the badge transmits less frequently. The LDR also adds to the randomness of transmissions from badge to badge, as it is virtually impossible for two badges to remain in synchronisation. The oscillator 16 is based around a BRY62 device and a BCX70J transistor which provides reset pulses to a microprocessor referred to below. It is possible to preempt the time out period of the relaxation oscillator 16;

- 9 -

this happens either by entering an RF field or pressing either or both of the pushbutton switches 14;

A microprocessor type 87C751, low current, small 28 pin PLCC package 18. This is the main component of the badge; it constitutes a controller, coding and decoding information and responding in a manner predetermined by the program information contained in the microprocessor. This program information is set during manufacture. The device security fuses are blown so that the program code cannot be accessed; this serves as a security measure should the badge become lost or stolen;

An 8 bit bi-directional digital I/O port 20 appertaining to the microprocessor 18. This 8 bit port 20 can be used to attach external control and monitoring equipment, such as a temperature sensor;

Two low current visible light emitting diodes (LEDs) 22 used to provide an indication of internal status information;

A piezo ceramic sounder 24 used to provide audible signalling information, bleeps and tunes;

An infra-red (IR) pr-amplifier circuit 26. This is based around an SL486 device which provides filtering and automatic gain control for reception of signals received from an IR receiver diode 28;

A very low on resistance field effect transistor (FET) 30, used to switch high current pulses of approximately 4.5 amps, through IR transmitting diodes 32. Two types of transmitting diodes 32 are employed; very wide beam angle

- 10 -

diode to provide good peripheral coverage, and narrower beam angle diode to provide good straight line range of approximately 40 to 50 metres.

Also included in the badge, although not shown, are two 3V lithium batteries, to provide power for the badge. The lithium batteries are especially well suited for their application; they provide an average current of less than 100 micro-amps when the badge is asleep, and bursts of current of approximately 10 milli-amps when the badge is active.

Associated with the batteries are reservoir capacitors of approximately 1000 micro-farads. These capacitors are charged from the lithium batteries, thereby to provide the 4.5 amp pulses which drive the IR transmitting diodes 32.

Referring now to Figure 2, there is shown one of the transceiver sensor stations which would be placed around a building or site to communicate with the active badges. The major component parts of these sensor stations are as follows:

An IR receiver diode 34 which receives IR signals transmitted from the active badges;

An IR pre-amplifier circuit 36, which is based around an SL486 device which provides filtering and automatic gain control for reception of signals received from the IR receiver diode 34. The component parts 34 and 36 constitute an IR receiver;

A very low on resistance field effect transistor (FET) 38, used to switch high current pulses of approximately 6 amps

- 11 -

through IR transmitting diodes 40. Again, two types of transmitting diodes are used; a very wide beam angle diode to provide good peripheral coverage, and a narrower beam angle diode to provide good straight line range of approximately 40 to 50 metres. The component parts 38 and 40 constitute an IR transmitter;

An IR coder-decoder (CODEC) chip 42, constituted by an 87C751 with program information placed within its internal memory during manufacture. This part of the circuit is used to perform the function of decoding and checking IR transmissions received from the IR receiver 34, 36. The CODEC 42 converts the IR transmission into parallel bytes of data and stores the bytes in a FIFO memory 44. The CODEC 42 also performs the function of taking the parallel data from a FIFO buffer memory 48, coding the information for transmission, and transmitting it via the IR transmitter 38, 40. The IR receive FIFO buffer memory 44 is used to buffer data received by the IR CODEC 42 for later onward transmission across a 4-wire network 46, while the FIFO buffer memory 48 provides buffering of data to be sent from the station via the IR transmitter, and in particular buffers data received from the 4-wire network 46 described below.

Thus, the memories 44, 48 perform two principal functions. Firstly they provide simple buffering of IR data received, ensuring that no incoming data is lost or overwritten, and buffering of IR data to be transmitted. The size of the buffer memory depends on the particular FIFO memory chips 44, 48 installed. The FIFO memory chips 44, 48 are contained within sockets, and hence can be easily removed and upgraded for larger devices if the need arises. As a minimum, the sensor stations will be fitted with 2K bytes

- 12 -

of buffer space in each direction; however 8K or 32K can easily be envisaged. Secondly, the use of the FIFO buffer memory chips 44, 48 enables the IR CODEC chip 42 to be completely decoupled from a station chip 50 described below. This is important to allow the two 87C751 microprocessors to work autonomously. The IR CODEC 42 is required to perform critical timing of the IR pulses being received and transmitted, hence it must not be interrupted by possible incoming data from the 4-wire network. Similarly, the station chip must perform critical timing of the data being received or sent over the 4-wire network, and must not be interrupted by possible incoming data from the IR receiver. Thus reception or transmission of IR data can occur completely asynchronously from communications across the 4-wire network.

The station chip 50 is an 87C751 with program information placed within its internal memory during manufacture. This component implements the functionality of a device commonly known as a universal asynchronous receiver transmitter (UART). It communicates with the 4-wire network 46, via a buffer circuit 52, checking and converting the data received. The station chip 50 contains a station identification number (ID) which is hard coded into its internal memory. The information received from the 4-wire network 46 is compared with the station ID, and if the data or command is for that station then the station chip acts on it accordingly. Data to be transmitted is placed into the FIFO buffer 48; if data is to be returned from the FIFO memory 44 this is sent back across the 4-wire network 46.

The station chip also has one single bit digital input and

- 13 -

one single bit digital output. It is possible to send commands to the station chip which will alter or return the state of the digital signals. These digital signals are terminated on connectors to which external equipment may be connected to enable basic monitoring and control to be implemented.

Buffer circuit 52 is a simple open collector driver and receiver circuit, which converts between TTL-level signals on the sensor station and the open-collector drive required for connection to the 4-wire network 46.

5 volt regulator 54 regulates the 12 volt DC power supplied to the station from the 4-wire network 46 to a 5 volt level for powering the station electronics. By using 12 volts DC power, it is possible to locate the sensor stations at distances of 100 metres or more from the network controller, as the voltage drop caused by long cable lengths is small enough to still provide sufficient power to the sensor station.

The 4-wire network 46 provides the power and communications mechanism for the network sensors. Two of the wires provide DC power, and the other two constitute a data transmit and receive line for communications. The protocols are identical to a simple serial communications port, as found on a personal computer or workstation. The transmit and receive data line is designed using open-collector drives so that multiple stations can be connected to the same 4 wires. The network operates at 9600 baud, but can be readily altered for lower or higher data rates if required. The use of the open-collector drive and 4 wire network allows for long cable lengths, whilst remaining practical and cost effective; the wiring

- 14 -

involved is no more complex than that for a simple telephone system.

Figure 3 is a block diagram of a network RF field generator/multi I/O station. The major components of this station are as follows:

Two 8 bit I/O ports 56 of an 87C751 microprocessor 58 are terminated in connectors accessible for external control and monitoring purposes. These may, for example, be used to monitor temperature, humidity, smoke detectors, alarm sensors and to control lights, heating, access and alarms.

The 87C751 microprocessor 58 is pre-loaded with custom developed software during manufacture. It performs the functions of a UART, communicating across the 4-wire network 46 and providing the means of monitoring and controlling various digital I/O ports.

A buffer circuit 60 is a simple open collector driver and receiver circuit which converts between TTL-level signals on the station and the open-collector drive required for connection to the 4-wire network 46.

A 5 volt regulator 62 regulates the 12 volt DC power supplied to the station from the 4-wire network 46 to a 5 volt level for powering the station electronics. As before, by using 12 volts DC power, it is possible to locate the stations at distances of 100 metres or more from the network controller, as the voltage drop caused by long cable lengths is small enough still to provide sufficient power to the sensor station.

- 15 -

A field generator circuit 64 is constituted by a single transistor oscillator stage. A tuned loop aerial 66 forms an integral part of the oscillator collector tuned circuit. The field generator can be switched on and off either by an external digital control signal, or from the station chip 58. The selection of the on/off control signal is made via a link 68. The field generator 64 can be powered from an external power supply, so that the circuit does not take current from the 4-wire network 46.

Link/switch 68 is used to select on/off control signal for the field generator.

An optional external power supply 72 is a 12 volt DC power supply, used to provide the power for the circuit when higher power RF transmissions are required. This avoids taking excessive power from the 4-wire network 46.

The 4-wire network 46 is identical to the network previously described above for the network sensor station (Figure 2).

Figure 4 is a block diagram of a workstation sensor unit. This unit is a variant of the network sensor in that the functionality it provides is identical except that there is no 4-wire network communication. The workstation sensor station communicates via a standard RS232 serial port. It is intended that the sensor station would connect directly to a PC or workstation serial port, and would use the existing infrastructure (e.g. Ethernet, Tokenring) for system communications. There is thus no need to install a dedicated 4-wire network where suitable infrastructure is already available.

- 16 -

Component parts 74 to 88 and 92 are respectively identical to component parts 34 to 44, 48, 50 and 54 (Figure 2).

Reference 90 denotes an RS232 to TTL buffer circuit which converts between the TTL levels of the station microprocessor and the RS232 levels of the serial communications port. The protocols are identical to those used on the 4-wire network 46.

Component parts 94 and 96 are identical to parts 64 and 66 of the network RF field generator unit (Figure 3).

The complete unit is powered from an external 12 volt DC power supply.

Figure 5 indicates a typical building layout, showing the units of the tracking and identification system which have been described with reference to Figures 1 to 4. The interconnection of the components is indicated, and descriptions of their use are given below:

A site computer facility 100 represents a central computer which is not essential for operation of the system, but is shown to provide an indication of how a typical system might be constructed. The computer facility 100 may be, for example, a simple shared file server, or a large multi-user mainframe. The central computer facility may be used to form a communications link to the outside world.

A local communications network 102 represents an existing communications infrastructure (e.g. Ethernet, Tokenring). The local network 102 is normally used to interconnect PCs, workstations, remote printers and various pieces of

- 17 -

equipment. The existence of such a network can be important, as it may be used to reduce or avoid the requirement for a special 4-wire active badge network to be installed. The system units may be deployed as appropriate and the existing local communication network used to provide the system topology.

Reference 104 denotes a PABX telephone exchange system, connected to the site computer infrastructure. This may be altered under software control (e.g. telephone calls being automatically re-routed, personal short-codes dynamically allocated to an extension as a user picks up the phone).

Reference 106 denotes the network controller; it is the central point where the 4-wire networks 46 emanate from. The simplest form of controller may be a single RS232 serial port of a PC or workstation. The RS232 port is connected via a level shifting interface unit, which also allows for the provision of the 12 volts DC power. The controller 106 could alternatively be a dedicated processor, and there may be one or more such controllers per building. The network controller 106 provides the function of interfacing between the 4-wire networks 46 and the rest of the site infrastructure. The controller 106 manages the communications to each of the network sensors (Figures 2 and 4); it collects the data, statistics e.g. station problems, stations being connected or disconnected, and exchanges data with the rest of the site system.

Also shown are the 4-wire networks 46, which are the physical wire connections which link the various system units placed around a building.

- 18 -

Reference 108 indicates an example of tagging objects or equipment. This tagging application can be used, for example, for inventory control, allowing lists of items and their locations to be automatically generated (video indexing). Using the digital I/O port of the active badge (Figure 1) the status of the equipment can be monitored and altered (e.g. is it on or off? If it's off then turn it on).

Reference 110 indicates an example of use of the system for location of a person. By tracking the movement of people, the system can monitor their position and report accordingly. The location information can be used by the system, for example to dynamically reprogram the PABX and hence re-route calls to the nearest telephone extension. The I/O port of the active badge (Figure 1) may be used to return additional information along with location information. Also, if a temperature sensor or pulse monitor were attached to the badge, then the badge could return bio-medical information regarding the health of the wearer. Thus the badge could be used for continual unobtrusive monitoring of a patient.

Reference 112 indicates use of the system as a pager. As it is possible to send commands and data to the badge, it is possible to instruct it to provide visual and audible signalling information, i.e. basic paging. By adding an LCD graphics display module to the I/O port, the paging features of the badge can be further expanded, by allowing it to provide a full messaging feature of say 40 characters by 4 rows. Other input devices such as a keypad or touch-sensitive area could be added to provide a portable terminal, from which cordless computer access can

- 19 -

be gained over the IR communications link.

Reference 114 indicates use of the system for access control. As a badge wearing person approaches a door, the badge will communicate with the sensor station positioned at the door. Data will be exchanged with the central controller; the system will issue an authentication command to the badge, along with a varying random number. The badge will return a challenge encrypted value, based on the badge password, and the system will confirm the authenticity of the badge. By using a random number and encryption algorithm, simply recording the transmissions from a badge and later simulating a badge transmission would not allow the perpetrator access, as the returned encrypted value would not match the one the system expects to receive for the random number challenge which was issued. If it is sufficient to assume the badge has not been misappropriated, then the system can instruct the door to unlock, and the person will be allowed to enter. If there is a requirement for a more secure system, then the person can be asked to enter a PIN number to a key pad located at the door entrance; the combination of the authenticated badge and personal secret PIN number provides a highly secure access control system.

As indicated at 115, when coupled with an alarm mechanism, the active badge system can be used to identify when people are present in the building, but not wearing active badges. Such a condition could be deemed an alarm condition, and the building security department alerted over the 4-wire network.

Section 116 of Figure 5 is expanded in Figure 6, and is

- 20 -

described in further detail below.

Figure 6 is an expanded view of a typical room such as 116 in Figure 5. Contained within the room are numerous sensors and devices. Some of the features have been described earlier, such as door access control, equipment location, telephone call re-routing and use of the local communications network. The two features of interest in Figure 6 which have not been mentioned previously are as follows:

The first, indicated at 118, concerns use of the active badge to provide automatic computer access. In a similar manner to access at a doorway, it is possible to configure a personal computer or workstation to automatically log-in and log-out a user. If a person leaves the locality of a computer or terminal, which he or she has been using, the system can perform a log-out or lock command, thus inhibiting unauthorised use of the machine. When the user confronts the same or another computer terminal, the person may be automatically logged-in, and his or her personal state of use is restored (e.g. if, say, part way through composing a letter, the person could leave the terminal, return, possibly to another terminal, and they would be automatically returned to the point where he or she left off, i.e. half way through composing the letter). The use of such an application provides a means of configuring shared computer facilities, which is becoming increasingly important as more and more shared work space environments become common.

Secondly, as indicated at 120, use may be made of the field generator stations to provide local zones within a defined IR area. It is possible to locate several fields

- 21 -

in one room; each field signals unique identification information to the badge field detector. A badge can thus detect which particular field it is in or near; this information is returned to the sensor stations along with the badge ID information. Using this additional location information, the position of a badge can be identified as, for example, room ABC located in field N. The field strength is pre-set so that the badge field detector only responds if it is closely located to the field generator. This provides a much finer granularity of location information; it is thus possible to know the position of a badge to within say one metre, if required.

There are numerous possible applications for the above-described system, which is generally referred to as a tracking and/or identification system; some examples of particular interest are given below, but these examples are in no way exhaustive.

A primary function of the active badge system is location of people and objects. Use of the location information gives rise to a wealth of applications, as follows:

Location information can be used for automatic control and dynamic reprogramming of facilities. Telephone calls can be re-directed to the extension nearest to the intended recipient, computers and workstations can be configured to the current user's personal requirements.

By using the localised field zone identification, the system can detect who has just picked-up a telephone extension to make a call. The personal short-codes for that user can be automatically configured to that extension, and hence the user has his or her own familiar

- 22 -

environment to hand.

The re-routing and automatic configuration can be easily extended to cover a much wider area. The home field data in the badge can be used, via the existing communications links, e.g. Internet, to exchange information, configure computers at different sites or even different countries and continents. Electronic mail can be forwarded to wherever the person is.

The paging features of the badge can be used as any normal pager would be; the system can be pre-programmed to send reminders, possibly at users' specified times; acknowledgment to user signalled commands could be provided, i.e. if someone presses a button, which has some pre-defined meaning, the badge could beep, thus signalling the acceptance and action of the button press. Additionally, when coupled with the location aspects of the badge system, paging could be used to automatically guide someone to an object, or to guide them around an unfamiliar site, or to help two or more people to rendezvous.

The challenge/response sequence, using the encrypted key and password, can be used to implement automatic access control. Physical access to buildings and facilities, and access to computer terminals, can be controlled. The system can be configured to control the locking and unlocking of doors; to open shop tills only when the assistant is local to the till; active badges in the form of airport active boarding passes would allow only a wearer to gain entry to restricted areas and eventually to board the aircraft.

- 23 -

All objects in a building can be tagged; this allows the system to track and log the movement of objects. Some simple application examples are: automatic inventory control, luggage monitoring at airports, the whereabouts of the nearest fire extinguisher.

Many of the applications mentioned above could be considered to be a sub-set of intelligent building applications. However, a few more building oriented applications could be the monitoring and control of the building infrastructure; alarm systems can be integrated, e.g. both burglar and fire alarms could be monitored using the sensor stations; heating, lighting and air conditioning could be controlled, dependent on the location of the people. In an emergency, when a building has to be evacuated, the badge system could show if everyone was out of the building and could report if and where people were trapped.

Sensors placed at critical points in a road or town area could be used to detect passing cars fitted with active badges. The system could be used to act as a toll monitor, checking the vehicles as they passed by the sensors. A simple extension of this could be used to form an access control system, allowing only authorised vehicles into designated areas.

Another area of interest is the unobtrusive monitoring of patients. If, for example, a temperature sensor is connected to the I/O port of a badge, then the badge could transmit temperature information from the sensor. This type of application allows for automatic continual monitoring of a patient without requiring the patient to be connected to a machine; the patient would be free to

- 24 -

move, would not be disturbed, and there would be no need for staff to use valuable time on routine monitoring.

Not only are many other applications of the system possible, but various modifications of the above-described and illustrated embodiment are possible, within the scope of the invention hereinbefore defined, for example to tailor the system to the particular use to which it is to be applied.

Claims

1. A tracking and identification system which comprises a plurality of active badges carried by a plurality of carriers within a predetermined area, each badge having an IR transmitter circuit for transmitting a unique IR identification signal, and a plurality of transceiver sensor stations in the predetermined area able to communicate both with the active badges and with a master control centre, wherein each active badge is arranged spontaneously to transmit its identification signal periodically, and is also able to transmit its identification signal on the occurrence of an external prompt.
2. A system according to claim 1, wherein the active badges normally reside in a power driven sleep condition mode and incorporate timing means which times out on a periodic basis to wake the badge and thereby cause it to transmit the IR identification signal.
3. A system according to claim 2, wherein the timing out period of the timing means is adjustable, whereby it can be set to be slightly different for each of the active badges in the system, thereby to achieve a randomness of IR transmission.
4. A system according to any of claims 1 to 3, wherein each of the active badges also has one or more user operable switching devices for waking the badge and causing it to transmit the IR identification signal.

- 26 -

5. A system according to any of claims 1 to 4, wherein each active badge incorporates an RF field detector, whereby the badge is also woken and thereby caused to transmit its IR identification signal responsive to entry of the carrier (and thereby the badge) into the RF field of an RF generating station of specific frequency and energy.

6. A system according to claim 4 or claim 5, wherein, when the badge is woken up by an external prompt, the badge transmits its IR identification data in combination with status information indicating which switching device was operated and/or which RF field or fields, the badge has entered or is in.

7. A system according to any of claims 1 to 6, wherein, before transmitting its IR identification signal, whether spontaneously or due to external prompt, the badge listens, by means of an IR receiving circuit, to determine if any other IR signal is currently being transmitted in the predetermined area and, if it is, either reverts to its sleep condition mode or holds back the transmission for a later attempt.

8. A system according to any of claims 1 to 7, wherein an identification number for each badge is held in the EPROM of a microprocessor within the badge.

9. A system according to claim 8, wherein the identification number which is set during manufacture, can be set to a 48 bit number (281 Terra combinations), thus providing for an effectively infinite number of active badges.

- 27 -

10. A system according to claim 9, when employed for video indexing.
11. A system according to any of claims 1 to 10, wherein all packets of data exchanged between a badge and a transceiver sensor station have a checksum attached, in order to maintain data integrity.
12. A system according to any of claims 1 to 11, wherein, following an IR transmission by a badge, a receiver circuit in the badge is operative for a listening period, before the badge reverts to its sleep condition mode, whereby during this listening period, data and commands can be sent to the badge by IR transmission.
13. A system according to claim 12, wherein the badge incorporates one or more indicators operative responsively to commands sent to the badge.
14. A system according to claim 13, wherein information relating to received commands is stored in a RAM internal to the badge, whereby, although the badge reverts to its sleep condition mode, stored information in the RAM can be retrieved by actuation of a switching device, thereby again to activate the indicators.
15. A system according to any of claims 1 to 14, wherein a RAM within the badge has an allocated section where home field data can be stored relating to the predetermined area to which a badge belongs, whereby, as each badge within an organisation can be set with its home field data, the badge can be interrogated when in a remote organisation.

- 28 -

16. A system according to any of claims 1 to 15, wherein each badge contains within a memory a unique secret password, which is part of a code inserted in the badge during manufacture, whereby when an interrogation signal is sent to the badge, the badge accepts the interrogation signal, combines it with the secret password and, using an encryption algorithm contained within the badge, calculates an encrypted reply which is returned to a transceiver sensor station for verification.

17. A system according to claim 5 or any claim when appendant to claim 5, wherein the RF field detector is a passive tuned circuit within the active badge.

18. A system according to claim 5 or any claim when appendant to claim 5, wherein the output of the RF field detector, when a carrier enters a relevant RF field, is used to wake the badge and to cause an IR transmission provided no other signal is being transmitted simultaneously.

19. A system according to claim 18, wherein, before transmitting the IR identification signal, the output of the RF field detector is monitored by a microprocessor.

20. A system according to claim 18 or claim 19, wherein the RF field transmitted to the badge is modulated to pass additional information to the badge, whereby several zoned RF fields can be located within one elemental area, and each of the fields can be uniquely identifiable by the active badge.

21. A system according to any of claims 1 to 20, wherein each active badge comprises a microprocessor, IR

- 29 -

transmitting diodes, an IR receiver, LED indicators, a piezo-ceramic speaker, pushbutton switches, a light dependent resistor (LDR), a relaxation oscillator and an RF field detection circuit.

22. A system according to claim 21, wherein the LDR is used to slow down spontaneous activations of the active badge at night.

23. A system according to claim 21 or claim 22, wherein each transceiver sensor unit comprises two microprocessors, two FIFO buffer memories, an IR receiver, an IR transmitter and an interface with a 4-wire network via which the transceiver unit can communicate with a master control centre.

24. A tracking and identification system substantially as hereinbefore described with reference to the accompanying drawings.

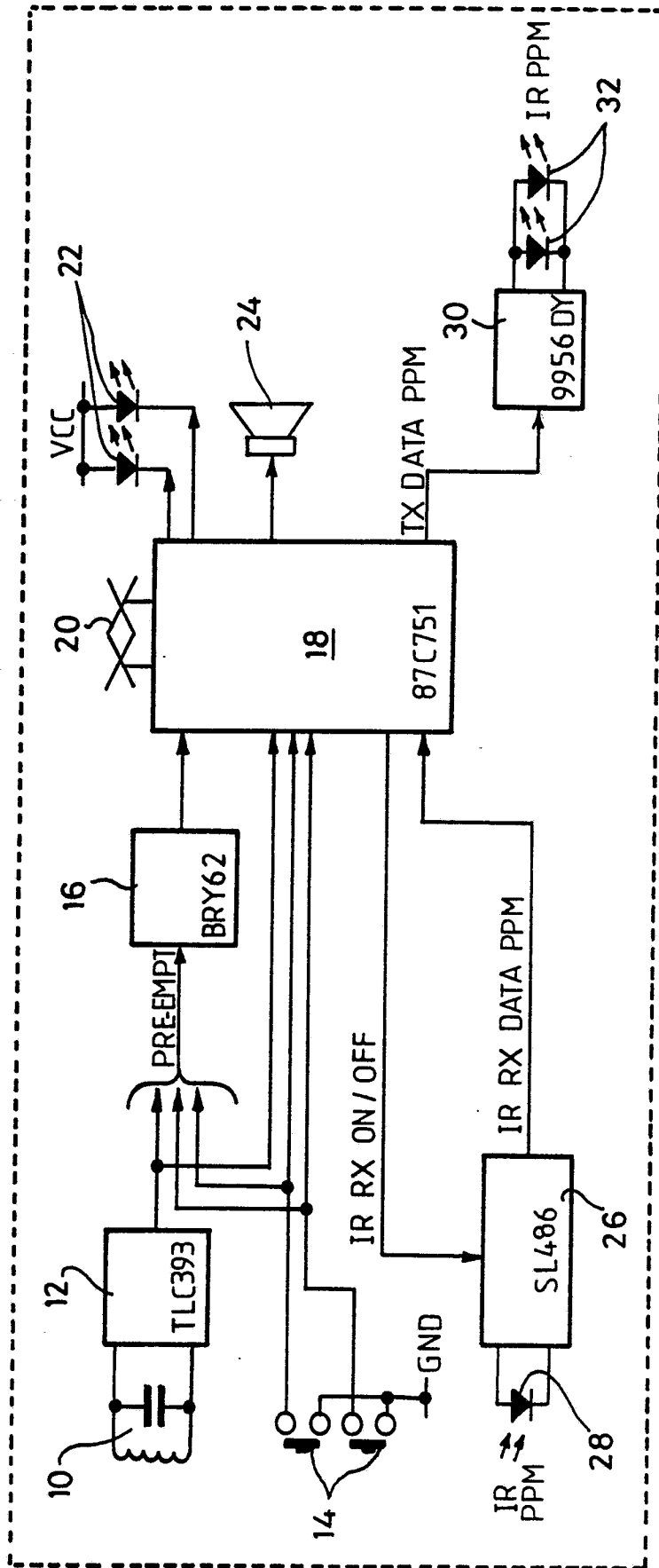

Fig. 1

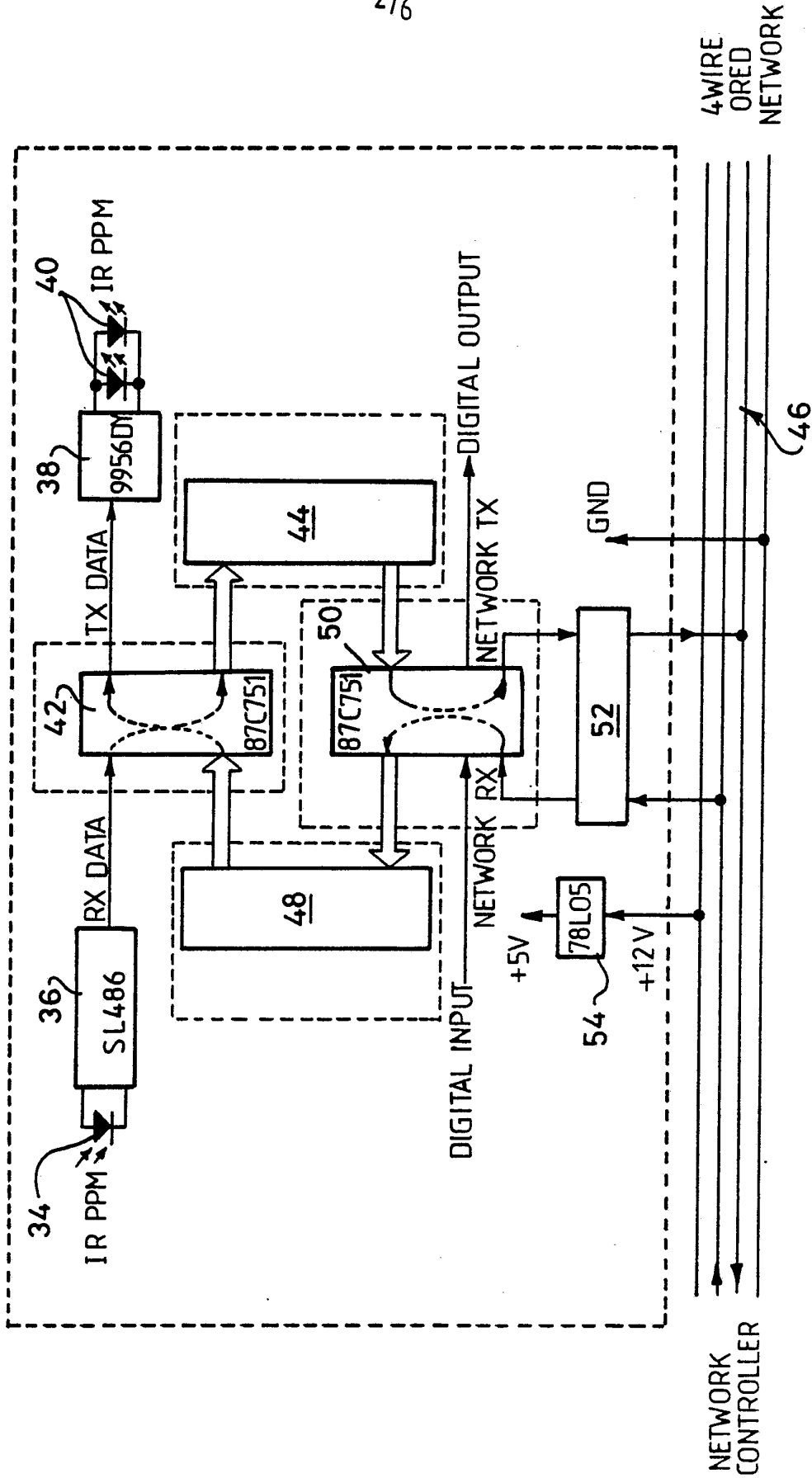

Fig. 2

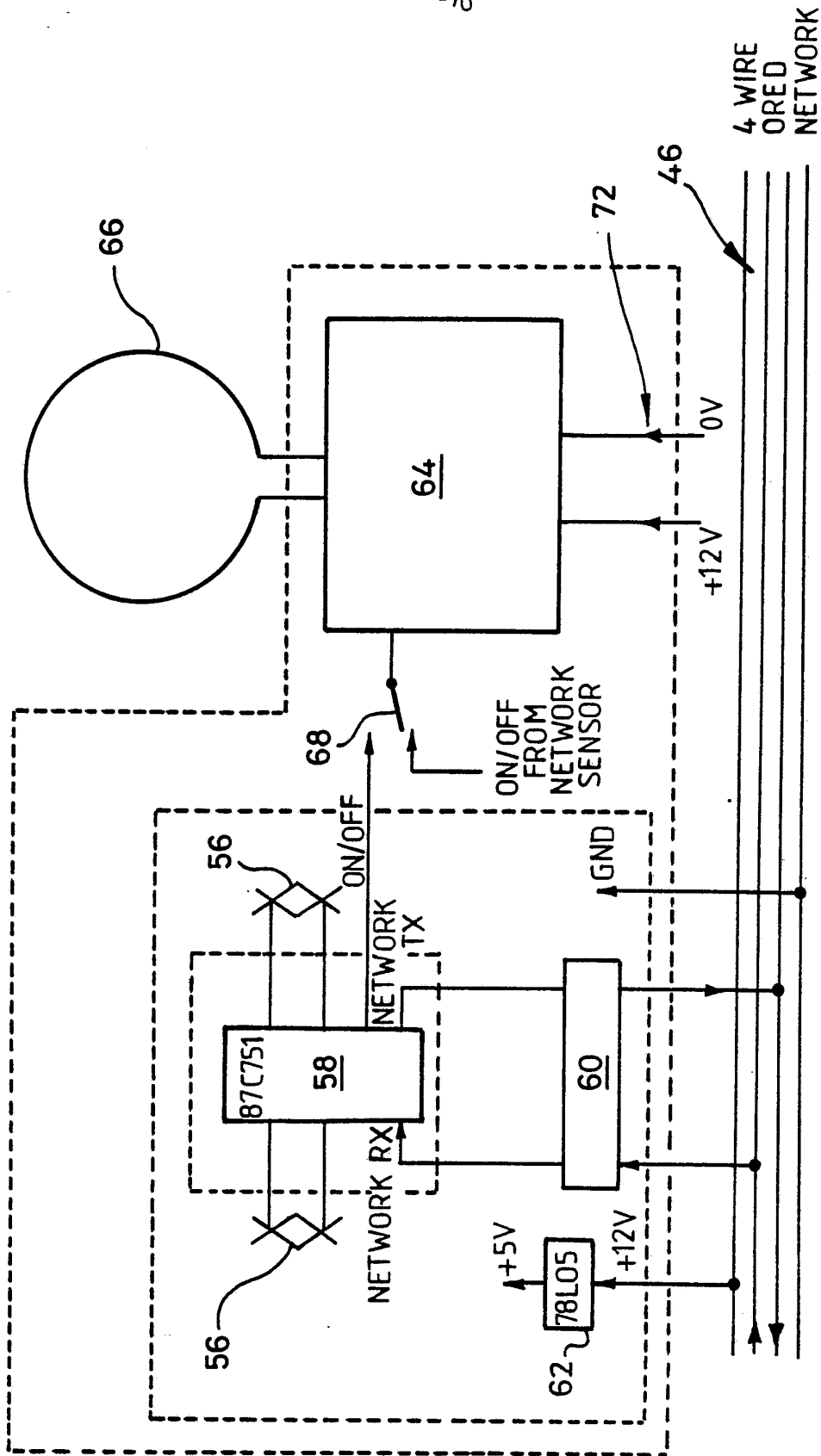

Fig. 3





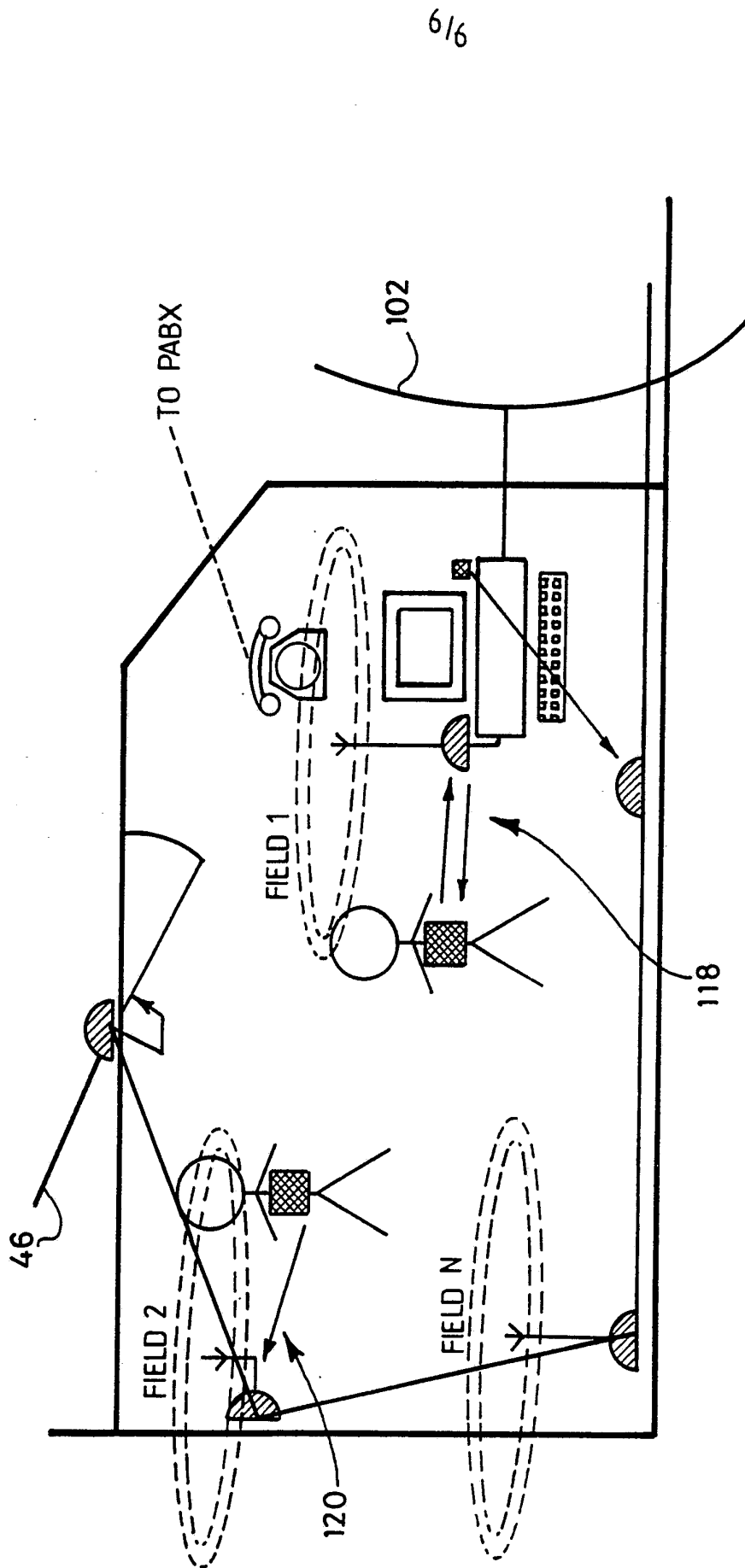

Fig. 6

INTERNATIONAL SEARCH REPORT

International Application No

PCT/GB 93/00476

<b>I. CLASSIFICATION OF SUBJECT MATTER</b> (if several classification symbols apply, indicate all) <sup>6</sup>		
According to International Patent Classification (IPC) or to both National Classification and IPC Int.Cl. 5 G06K7/00;                      G06K7/10;                      G07C9/00		
<b>II. FIELDS SEARCHED</b>		
Minimum Documentation Searched <sup>7</sup>		
Classification System	Classification Symbols	
Int.Cl. 5	G06K ;                      G07C	
Documentation Searched other than Minimum Documentation to the Extent that such Documents are Included in the Fields Searched <sup>8</sup>		
<b>III. DOCUMENTS CONSIDERED TO BE RELEVANT<sup>9</sup></b>		
Category <sup>10</sup>	Citation of Document, <sup>11</sup> with indication, where appropriate, of the relevant passages <sup>12</sup>	Relevant to Claim No. <sup>13</sup>
Y	EP,A,0 333 459 (UNITED MANUFACTURING CO., INC.) 20 September 1989 see claims 1,2,4-6,8,12-16,18-20,22	1-3,5-8, 12,15, 18,20
A	----	22
Y	EP,A,0 073 644 (ALLFLEX INTERNATIONAL LTD) 9 March 1983  see page 6, line 3 - line 5	1-3,5-8, 12,15, 18,20
A	----	
A	EP,A,0 108 643 (AUSTRALIAN MEAT AND LIVE-STOCK CORPORATION) 16 May 1984 see page 3, line 14 - line 25	1,5,6, 15,18,20
A	----	
A	US,A,4 236 068 (WALTON C.A.) 25 November 1980 see claim 9	1,4
	----	
		-/--
<p><sup>10</sup> Special categories of cited documents:</p> <p>"A" document defining the general state of the art which is not considered to be of particular relevance</p> <p>"E" earlier document but published on or after the international filing date</p> <p>"L" document which may throw doubts on priority claim(s) or which is cited to establish the publication date of another citation or other special reason (as specified)</p> <p>"O" document referring to an oral disclosure, use, exhibition or other means</p> <p>"P" document published prior to the international filing date but later than the priority date claimed</p> <p>"T" later document published after the international filing date or priority date and not in conflict with the application but cited to understand the principle or theory underlying the invention</p> <p>"X" document of particular relevance; the claimed invention cannot be considered novel or cannot be considered to involve an inventive step</p> <p>"Y" document of particular relevance; the claimed invention cannot be considered to involve an inventive step when the document is combined with one or more other such documents, such combination being obvious to a person skilled in the art.</p> <p>"&amp;" document member of the same patent family</p>		
<b>IV. CERTIFICATION</b>		
Date of the Actual Completion of the International Search	Date of Mailing of this International Search Report	
17 JUNE 1993	29. 06. 93	
International Searching Authority	Signature of Authorized Officer	
EUROPEAN PATENT OFFICE	HERSKOVIC M.	

III. DOCUMENTS CONSIDERED TO BE RELEVANT (CONTINUED FROM THE SECOND SHEET)		
Category °	Citation of Document, with indication, where appropriate, of the relevant passages	Relevant to Claim No.
A	US,A,4 384 288 (WALTON,C.A.) 17 May 1983 see the whole document ---	4,17
A	GB,A,2 230 365 (OLIVETTI RESEARCH LTD) 17 October 1990 see figure 1B ---	23
A	EP,A,0 416 792 (GAUTHIER,M.J.) 13 March 1991 see claims 1-3 ---	13
A	US,A,4 275 385 (WHITE,L.L.) 23 June 1981 see the whole document -----	1,11,23

**ANNEX TO THE INTERNATIONAL SEARCH REPORT  
ON INTERNATIONAL PATENT APPLICATION NO.**

GB 9300476  
SA 70983

This annex lists the patent family members relating to the patent documents cited in the above-mentioned international search report.  
The members are as contained in the European Patent Office EDP file on  
The European Patent Office is in no way liable for these particulars which are merely given for the purpose of information. 17/06/93

Patent document cited in search report	Publication date	Patent family member(s)	Publication date
EP-A-0333459	20-09-89	US-A- 4906853	06-03-90
		JP-A- 2028581	30-01-90
		US-A- 5027314	25-06-91
		US-A- 5017794	21-05-91
EP-A-0073644	09-03-83	AU-A- 8754982	03-03-83
		JP-A- 58052586	28-03-83
EP-A-0108643	16-05-84	AU-A- 2105083	17-05-84
		CA-A- 1233882	08-03-88
		DE-A- 3374962	28-01-88
US-A-4236068	25-11-80	EP-A,B 0017448	15-10-80
US-A-4384288	17-05-83	None	
GB-A-2230365	17-10-90	GB-A- 2260208	07-04-93
EP-A-0416792	13-03-91	GB-A- 2236354	03-04-91
US-A-4275385	23-06-81	None	