

(12) PATENT
(19) AUSTRALIAN PATENT OFFICE

(11) Application No. AU 199853639 B2
(10) Patent No. 736265

(54) Title
Multiple mode digital X-ray imaging system

(51)⁷ International Patent Classification(s)
G06T 005/20

(21) Application No: **199853639**

(22) Application Date: **1997.11.26**

(87) WIPO No: **WO98/24059**

(30) Priority Data

(31) Number	(32) Date	(33) Country
08/753799	1996.11.29	US
60/056926	1996.11.29	US
08/978177	1997.11.25	US

(43) Publication Date : **1998.06.22**

(43) Publication Journal Date : **1998.08.13**

(44) Accepted Journal Date : **2001.07.26**

(71) Applicant(s)
Varian Medical Systems, Inc.

(72) Inventor(s)
Richard E. Colbeth; John M. Pavokovich; Edward J. Seppi; Edward G. Shapiro

(74) Agent/Attorney
PHILLIPS ORMONDE and FITZPATRICK, 367 Collins Street, MELBOURNE VIC 3000

(56) Related Art
EP 0776124
US 5657400



INTE

(51) International Patent Classification 6 : G06T 5/20	A1	(11) International Publication Number: WO 98/24059 (43) International Publication Date: 4 June 1998 (04.06.98)
--	-----------	--

(21) International Application Number: PCT/US97/21685
 (22) International Filing Date: 26 November 1997 (26.11.97)
 (30) Priority Data:
 08/753,799 29 November 1996 (29.11.96) US
 60/056,926 29 November 1996 (29.11.96) US
 08/978,177 25 November 1997 (25.11.97) US
 (71) Applicant: VARIAN ~~ASSOCIATES, INC.~~ **MEDICAL SYSTEMS INC.** [US/US]; 3050 Hansen Way, Palo Alto, CA 94304 (US).
 (72) Inventors: COLBETH, Richard, E.; 1243 Richardson Avenue, Los Altos, CA 94024 (US). PAVOKOVICH, John, M.; 2945 Alexis Drive, Palo Alto, CA 94304 (US). SEPPI, Edward, J.; 320 Dedalera Drive, Portola Valley, CA 94028 (US). SHAPIRO, Edward, G.; 252 Andsbury Avenue, Mountain View, CA 94043 (US).
 (74) Agents: AU YANG, Hunter, L. et al.; Varian Associates, Inc., 3100 Hansen Way, Legal Dept., M/S E-339, Palo Alto, CA 94304 (US).
 (81) Designated States: AU, CA, JP, European patent (AT, BE, CH, DE, DK, ES, FI, FR, GB, GR, IE, IT, LU, MC, NL, PT, SE).
Published
With international search report.
Before the expiration of the time limit for amending the claims and to be republished in the event of the receipt of amendments.



(54) Title: MULTIPLE MODE DIGITAL X-RAY IMAGING SYSTEM

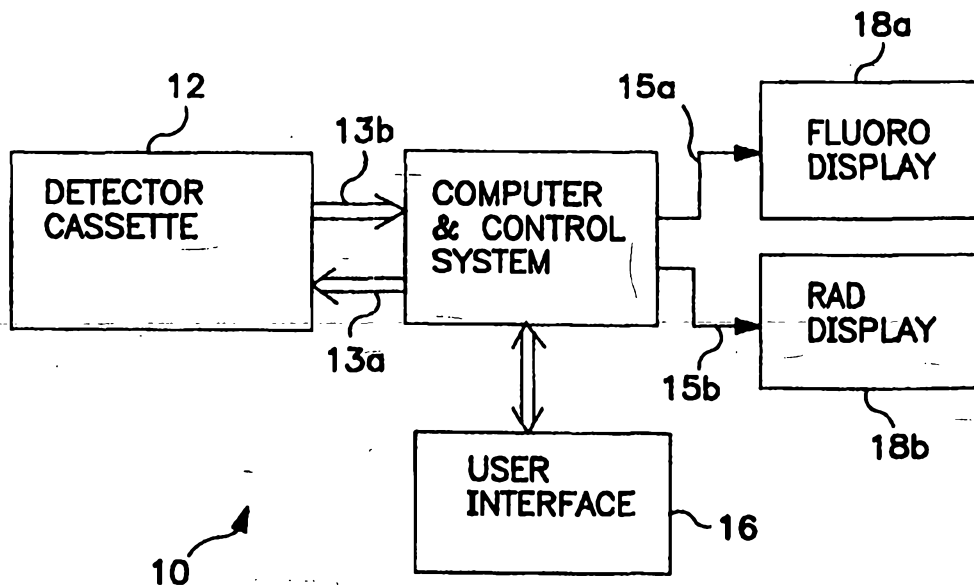

(57) Abstract
 A multiple mode digital X-ray imaging system providing for preprocessing "binning" of analog pixel signals from a detector array by selectively summing, within the detector array, adjacent pixel charges on a row-by-row basis and selectively summing, within detector array readout circuits, the previously summed pixel charges (by rows) on a column-by-column basis. An array, or mapping, of "defective pixel" flags is used to identify defective pixels within the detector array, with such flags being added to, or inserted into, the incoming data stream for dynamic processing along with the incoming pixel data. A buffer and filter is used to perform still image capture during the radiographic mode of operation and to recursively filter incoming data frames during the fluoroscopic mode of operation by summing a scaled amount of pixel data from prior data frames with a scaled amount of incoming pixel data from the present data frame.

MULTIPLE MODE DIGITAL X-RAY IMAGING SYSTEM

RELATED APPLICATIONS

This application claims the benefit of U.S. Provisional Application No. 60/056,926 which was converted to provisional status from U.S. Non-Provisional Application No. 08/753,799, which was filed on November 29, 1996, and entitled "Multiple Mode Digital X-Ray Imaging System."

5

BACKGROUND OF THE INVENTION

The present invention relates to radiation imaging systems, and in particular, to solid state X-ray radiation imaging systems capable of operating in multiple detection and display modes.

10

DESCRIPTION OF THE RELATED ART

The use of X-ray radiation has become a valuable and widespread tool in medical diagnoses and treatments. In film radiography, a burst of X-rays, after passing through the body, is recorded on high resolution X-ray film. In fluoroscopy, an image intensifier tube converts X-ray radiation to a video signal for viewing and recording interior body activity as a video image.

15

Film radiography is commonly used due to its good spatial resolution, high signal-to-noise ratio (SNR), large detection area and low cost. However, developing exposed X-ray film typically takes a minimum of ninety seconds which can be too long in emergency situations. Further, the relatively low dynamic range of X-ray film can result in under- or over-exposed images and, therefore, necessitate additional exposures which increase the aforementioned time delay as well as the X-ray dosage received by the patient.

20

The image intensifier tube used in fluoroscopy has a greater exposure latitude than

X-ray film, but also has a more limited active detection area and lower spatial resolution.

The lower spatial resolution associated with the total active area is somewhat mitigated in

that the image intensifier tubes allow magnification of the central image portion, thereby

providing a means to enhance visual details. However, the image intensifier tube is typically

5 heavy, bulky and expensive, and can introduce image distortion which can only be partially removed during post processing.

A number of alternative X-ray imaging technologies have been developed. For example, one alternative, known as computed radiography, involves the use of a

photostimulable phosphor plate which has the same physical appearance as a standard X-ray

10 film cassette and provides good spatial resolution, SNR and dynamic range. However, after exposure to X-rays, the photostimulable phosphor plate must be scanned with a laser system which is large and expensive, and the readout process is just as slow as the development of film.

Another alternative which provides good spatial resolution and dynamic range, as

15 well as the added advantage of compatibility with real time digital image processing techniques, involves the use of solid state detector panels. One such panel uses an

amorphous silicon (a-Si) detector array arranged as a two dimensional matrix of pixels, each

of which consists of a photosensitive element and a transistor switch. As with X-ray film

cassettes, the detector array is covered with a scintillation layer to convert impinging X-rays

20 into visible light for the photosensitive elements.

SUMMARY OF THE INVENTION

An X-ray imaging system in accordance with the present invention is capable of operating in multiple imaging modes, such as radiographic and fluoroscopic, while providing spatial resolutions, SNRs and dynamic ranges
 5 which can be selectively optimized to the selected mode of operation.

According to one aspect of the present invention there is provided an apparatus including a multiple mode X-ray imaging system for supporting multiple X-ray image display modes by providing X-ray image signals having selectable
 10 spatial resolutions in a still image mode or an image motion mode with correction for defective pixels individually or in groups, including:

a detector array configured to receive a plurality of detector control signals and in accordance therewith

15 receive and convert a plurality of X-ray photons corresponding to a two-dimensional image into a first plurality of image signals representing a first two-dimensional array which includes a first plurality of rows and a first plurality of columns of pixels which together correspond to said two-
 20 dimensional image and which individually correspond to respective portions of said two-dimensional image, and

provide a second plurality of image signals representing a second two-dimensional array which includes a second plurality of rows and said first
 25 plurality of columns of pixels which selectively represent respective individual ones or multiple adjacent ones of said first plurality of rows of pixels and respective individual ones of said first plurality of columns of
 30 pixels, respectively;

a plurality of detector array receiver circuits, coupled to said detector array, configured to receive a plurality of receiver control signals and in accordance
 therewith receive and combine said second plurality of image signals and in
 accordance therewith provide a third plurality of image signals representing a third

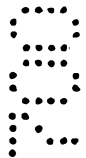
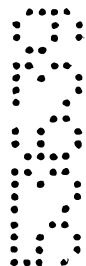

two-dimensional array which includes said second plurality of rows and a second plurality of columns of super pixels which selectively represent respective individual ones of said second plurality of rows of super pixels and respective individual ones or multiple adjacent ones of said first plurality of columns of super pixels, respectively;

5 a first data processing circuit, coupled to said plurality of detector array receiver circuits, configured to receive and process together said third plurality of image signals with a corresponding plurality of successive sets of correction data and in accordance therewith provide a plurality of successive sets of corrected image data, wherein said plurality of successive sets of correction data represents a plurality of
10 correction factors, each one of said plurality of correction factors corresponds to a respective one of said plurality of super pixels and each one of said plurality of successive sets of correction data includes a first data subset which indicates whether said respective one of said plurality of super pixels is defective;

15 a first data selection circuit, coupled to said first data processing circuit, configured to receive and select between individual ones of said plurality of successive sets of corrected image data and individual ones of said corresponding plurality of successive sets of correction data and in accordance therewith provide a first plurality of successive sets of selected data, wherein an individual one of said
20 first plurality of successive sets of selected data includes a corresponding individual one of said plurality of successive sets of correction data when said first data subset indicates that said corresponding respective one of said plurality of pixels is defective, and wherein said individual one of said first plurality of successive sets of selected data includes a corresponding one of said plurality of successive sets of

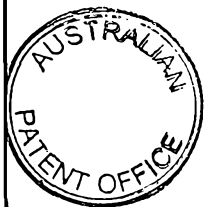

corrected image data when said first data subset does not indicate that said corresponding respective one of said plurality of pixels is defective;

5 a data scaling and summing circuit, coupled to said first data selection circuit, configured to receive and scale said first plurality of successive sets of selected data, receive and scale a stored data sum signal and sum said scaled first plurality of successive sets of selected data and said scaled stored data sum signal and in accordance therewith provide a data sum signal, wherein said first plurality of successive sets of selected data is scaled in accordance with a first scaling factor and said stored data sum signal is scaled in accordance with a second scaling factor, and
10 wherein said first plurality of successive sets of selected data includes a plurality of successive sets of image data, and further wherein each one of said plurality of successive sets of image data includes a plurality of super pixel data with active and inactive data states and which corresponds to said third two-dimensional array; and

15 a data memory circuit, coupled to said data scaling and summing circuit, configured to receive and selectively store said data sum signal and in accordance therewith provide said stored data sum signal;

wherein said data scaling and summing circuit and said data memory circuit cooperatively operate in one of a plurality of operational modes during said reception of said first plurality of successive sets of selected data;

20 wherein, in a first one of said plurality of operational modes,

said first scaling factor has a value which is between zero and unity,

and

said second scaling factor has a value which equals a difference



between unity and said first scaling factor value; and
 wherein, in a second one of said plurality of operational modes,

said first scaling factor has a value which is initially unity when a first
 one of said plurality of successive sets of image data is in said inactive data
 5 state, remains unity when a subsequent second one of said plurality of
 successive sets of image data is in said active data state and becomes zero
 when a further subsequent third one of said plurality of successive sets of
 image data is in said inactive data state, and

said second scaling factor has a value which is initially zero, becomes
 10 unity when said subsequent second one of said plurality of successive sets of
 image data is in said active data state and remains unity thereafter.

According to a further aspect of the present invention there is provided
 an apparatus including a multiple mode X-ray detector system for supporting
 multiple X-ray image display modes by providing X-ray image signals having selectable
 15 spatial resolutions, including:

a detector array configured to receive a plurality of detector control signals
 and in accordance therewith

receive and convert a plurality of X-ray photons corresponding to a
 two-dimensional image into a first plurality of image signals representing a
 20 first two-dimensional array which includes a first plurality of rows and a first
 plurality of columns of pixels which together correspond to said two-
 dimensional image and which individually correspond to respective portions of
 said two-dimensional image, and



provide a second plurality of image signals representing a second two-dimensional array which includes a second plurality of rows and said first plurality of columns of pixels which selectively represent respective individual ones or multiple adjacent ones of said first plurality of rows of pixels and respective individual ones of said first plurality of columns of pixels, respectively; and

5

a plurality of detector array receiver circuits, coupled to said detector array, configured to receive a plurality of receiver control signals and in accordance therewith receive and combine said second plurality of image signals and in

10

accordance therewith provide a third plurality of image signals representing a third two-dimensional array which includes said second plurality of rows and a second plurality of columns of super pixels which selectively represent respective individual ones of said second plurality of rows of super pixels and respective individual ones or multiple adjacent ones of said first plurality of columns of super pixels, respectively;

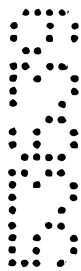

15

wherein said plurality of detector array receiver circuits comprises a plurality of capacitive switching circuits configured to receive a portion of said plurality of receiver control signals and in accordance therewith receive and combine selected ones of said second plurality of image signals and in accordance therewith provide said third plurality of image signals.



20

According to a still further aspect of the present invention there is provided an apparatus including a data processing system for processing a serial stream of multiple bit data sets which represent an array of pixels corresponding to a two-dimensional image including correcting for defective pixels individually or in groups, including:

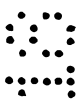

25

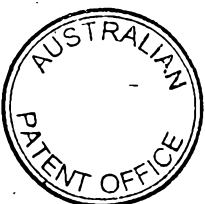

a first data processing circuit configured to receive and process together a plurality of successive sets of image data with a corresponding plurality of successive sets of correction data and in accordance therewith provide a plurality of successive sets of corrected image data, wherein said plurality of successive sets of image data represents a plurality of pixels corresponding to a two-dimensional image, said plurality of successive sets of correction data represents a plurality of correction factors, each one of said plurality of correction factors corresponds to a respective one of said plurality of pixels and each one of said plurality of successive sets of correction data includes a first data subset which indicates whether said respective one of said plurality of pixels is defective; and

a first data selection circuit, coupled to said first data processing circuit, configured to receive and select between individual ones of said plurality of successive sets of corrected image data and individual ones of said corresponding plurality of successive sets of correction data and in accordance therewith provide a first plurality of successive sets of selected data, wherein an individual one of said first plurality of successive sets of selected data includes a corresponding individual one of said plurality of successive sets of correction data when said first data subset indicates that said corresponding respective one of said plurality of pixels is defective, and wherein said individual one of said first plurality of successive sets of selected data includes a corresponding one of said plurality of successive sets of corrected image data when said first data subset does not indicate that said corresponding respective one of said plurality of pixels is defective.



According to a still further aspect of the present invention there is provided an apparatus including a digital data buffer and filter for selectively storing image pixel data, combining new incoming image pixel data with previously stored image pixel data and providing such combined image pixel
 5 data for display thereof in a still image mode or an image motion mode, including:

a data scaling and summing circuit configured to receive and scale an input data signal, receive and scale a stored data sum signal and sum said scaled input data signal and said scaled stored data sum signal and in accordance therewith provide a
 10 data sum signal, wherein said input data signal is scaled in accordance with a first scaling factor and said stored data sum signal is scaled in accordance with a second scaling factor, and wherein said input data signal includes a plurality of successive sets of image data, and further wherein each one of said plurality of successive sets of image data includes a plurality of pixel data with active and inactive data states and which corresponds to a two-dimensional image having a two-dimensional array including a plurality of rows and a plurality of columns of pixels which together correspond to said two-dimensional image and which individually correspond to
 15 respective portions of said two-dimensional image; and

a data memory circuit, coupled to said data scaling and summing circuit, configured to receive and selectively store said data sum signal and in accordance
 20 therewith provide said stored data sum signal;

wherein said data scaling and summing circuit and said data memory circuit cooperatively operate in one of a plurality of operational modes during said reception

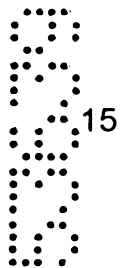

15

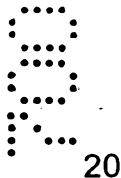

20



25



of said input data signal;

wherein, in a first one of said plurality of operational modes,

said first scaling factor has a value which is between zero and unity,

and

5 said second scaling factor has a value which equals a difference
between unity and said first scaling factor value; and

wherein, in a second one of said plurality of operational modes,

10 said first scaling factor has a value which is initially unity when a first
one of said plurality of successive sets of image data is in said inactive data
state, remains unity when a subsequent second one of said plurality of
successive sets of image data is in said active data state and becomes zero
when a further subsequent third one of said plurality of successive sets of
image data is in said inactive data state, and

15 said second scaling factor has a value which is initially zero, becomes
unity when said subsequent second one of said plurality of successive sets of
image data is in said active data state and remains unity thereafter.

20 According to a still further aspect of the present invention there is
provided an apparatus including a multiple mode X-ray imaging system for
supporting multiple X-ray image display modes by providing X-ray image
signals having selectable spatial resolutions in a still image mode or an image
motion mode including correcting for defective pixels individually or in groups,
including:

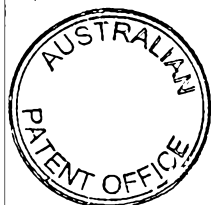

a detector array configured to receive a plurality of detector control signals and in accordance therewith receive and convert a plurality of X-ray photons into a first plurality of image signals, wherein

5

said plurality of X-ray photons correspond to a two-dimensional image represented by a first two-dimensional array which includes a first plurality of rows and a first plurality of columns of pixels which together correspond to said two-dimensional image and which individually correspond to respective portions of said two-dimensional image, and

10

said first plurality of image signals represent a second two-dimensional array which includes a second plurality of rows and said first plurality of columns of pixels which selectively represent respective individual ones or multiple adjacent ones of said first plurality of rows of pixels and respective individual ones of said first plurality of columns of pixels, respectively;

15

a plurality of detector array receiver circuits, coupled to said detector array, configured to receive a plurality of receiver control signals and in accordance therewith receive and combine said first plurality of image signals and in accordance therewith provide a second plurality of image signals representing a third two-dimensional array which includes said second plurality of rows and a second plurality of columns of super pixels which selectively represent respective individual ones of said second plurality of rows of super pixels and respective individual ones or

20

25

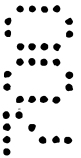
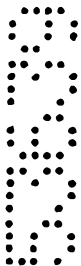

multiple adjacent ones of said first plurality of columns of super pixels, respectively;

a first data processing circuit, coupled to said plurality of detector array receiver circuits, configured to receive and process together said second plurality of image signals with a corresponding plurality of successive sets of correction data and in accordance therewith provide a plurality of successive sets of corrected image data, wherein said plurality of successive sets of correction data represents a plurality of correction factors, each one of said plurality of correction factors corresponds to a respective one of said plurality of super pixels and each one of said plurality of successive sets of correction data includes a first data subset which indicates whether said respective one of said plurality of super pixels is defective;

a first data selection circuit, coupled to said first data processing circuit, configured to receive and select between individual ones of said plurality of successive sets of corrected image data and individual ones of said corresponding plurality of successive sets of correction data and in accordance therewith provide a first plurality of successive sets of selected data, wherein an individual one of said first plurality of successive sets of selected data includes a corresponding individual one of said plurality of successive sets of correction data when said first data subset indicates that said corresponding respective one of said plurality of pixels is defective, and wherein said individual one of said first plurality of successive sets of selected data includes a corresponding one of said plurality of successive sets of corrected image data when said first data subset does not indicate that said corresponding respective one of said plurality of pixels is defective;

a data scaling and summing circuit, coupled to said first data selection circuit,

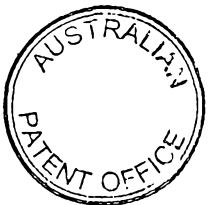

configured to receive and scale said first plurality of successive sets of selected data,
 receive and scale a stored data sum signal and sum said scaled first plurality of
 successive sets of selected data and said scaled stored data sum signal and in
 accordance therewith provide a data sum signal, wherein said first plurality of
 5 successive sets of selected data is scaled in accordance with a first scaling factor and
 said stored data sum signal is scaled in accordance with a second scaling factor, and
 wherein said first plurality of successive sets of selected data includes a plurality of
 successive sets of image data, and further wherein each one of said plurality of
 successive sets of image data includes a plurality of super pixel data with active and
 10 inactive data states and which corresponds to said third two-dimensional array; and
 a data memory circuit, coupled to said data scaling and summing circuit,
 configured to receive and selectively store said data sum signal and in accordance
 therewith provide said stored data sum signal;

wherein said data scaling and summing circuit and said data memory circuit
 15 cooperatively operate in one of a plurality of operational modes during said reception
 of said first plurality of successive sets of selected data;

wherein, in a first one of said plurality of operational modes,

said first scaling factor has a value which is between zero and unity,

and

20 said second scaling factor has a value which equals a difference

between unity and said first scaling factor value; and

wherein, in a second one of said plurality of operational modes,

said first scaling factor has a value which is initially unity when a first

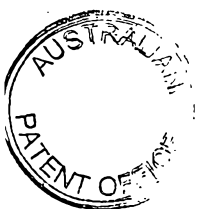

one of said plurality of successive sets of image data is in said inactive data state, remains unity when a subsequent second one of said plurality of successive sets of image data is in said active data state and becomes zero when a further subsequent third one of said plurality of successive sets of image data is in said inactive data state, and

5

said second scaling factor has a value which is initially zero, becomes unity when said subsequent second one of said plurality of successive sets of image data is in said active data state and remains unity thereafter.

According to a still further aspect of the present invention there is provided a method of providing X-ray image signals having selectable spatial resolutions in a still image mode or an image motion mode including correcting for defective pixels individually or in groups, including the steps of:

10

receiving a plurality of detector control signals and in accordance therewith:

receiving and converting a plurality of X-ray photons which correspond to a two-dimensional image into a first plurality of image signals which represent a first two-dimensional array including a first plurality of rows and a first plurality of columns of pixels which together correspond to said two-dimensional image and which individually correspond to respective portions of said two-dimensional image, and

15

generating a second plurality of image signals which represent a second two-dimensional array including a second plurality of rows and said first plurality of columns of pixels which selectively represent respective individual ones or multiple adjacent ones of said first plurality of rows of

20

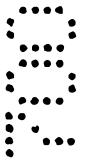
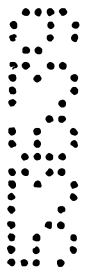

pixels and respective individual ones of said first plurality of columns of pixels, respectively; and

receiving a plurality of receiver control signals and in accordance therewith receiving and combining said second plurality of image signals and in accordance
 5 therewith generating a third plurality of image signals which represent a third two-dimensional array including said second plurality of rows and a second plurality of columns of super pixels which selectively represent respective individual ones of said second plurality of rows of super pixels and respective individual ones or multiple adjacent ones of said first plurality of columns of super pixels, respectively;

10 receiving and processing together said third plurality of image signals with a corresponding plurality of successive sets of correction data and in accordance therewith generating a plurality of successive sets of corrected image data, wherein said plurality of successive sets of correction data represents a plurality of correction factors, each one of said plurality of correction factors corresponds to a respective
 15 one of said plurality of super pixels and each one of said plurality of successive sets of correction data includes a first data subset which indicates whether said respective one of said plurality of super pixels is defective;

selecting between individual ones of said plurality of successive sets of corrected image data and individual ones of said corresponding plurality of successive
 20 sets of correction data and in accordance therewith generating a first plurality of successive sets of selected data, wherein an individual one of said first plurality of successive sets of selected data includes a corresponding individual one of said plurality of successive sets of correction data when said first data subset indicates that

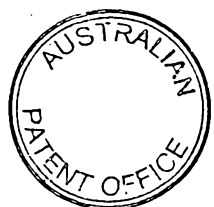

said corresponding respective one of said plurality of pixels is defective, and wherein said individual one of said first plurality of successive sets of selected data includes a corresponding one of said plurality of successive sets of corrected image data when said first data subset does not indicate that said corresponding respective one of said plurality of pixels is defective;

5

receiving and scaling said first plurality of successive sets of selected data, receiving and scaling a stored data sum signal and summing said scaled first plurality of successive sets of selected data and said scaled stored data sum signal and in accordance therewith generating a data sum signal, wherein said first plurality of successive sets of selected data is scaled in accordance with a first scaling factor and said stored data sum signal is scaled in accordance with a second scaling factor, and wherein said first plurality of successive sets of selected data includes a plurality of successive sets of image data, and further wherein each one of said plurality of successive sets of image data includes a plurality of super pixel data with active and inactive data states and which corresponds to said third two-dimensional array; and

10

selectively storing said data sum signal and in accordance therewith generating said stored data sum signal;

15

wherein said step of receiving and scaling said first plurality of successive sets of selected data, receiving and scaling a stored data sum signal and summing said scaled first plurality of successive sets of selected data and said scaled stored data sum signal and in accordance therewith generating a data sum signal and said step of selectively storing said data sum signal and in accordance therewith generating said stored data sum signal are cooperatively performed in one of a plurality of

20

25

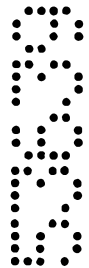

performance modes during said reception of said first plurality of successive sets of selected data;

wherein, in a first one of said plurality of performance modes,

said first scaling factor has a value which is between zero and unity,

5

and

said second scaling factor has a value which equals a difference

between unity and said first scaling factor value; and

wherein, in a second one of said plurality of performance modes,

said first scaling factor has a value which is initially unity when a first

10

one of said plurality of successive sets of image data is in said inactive data

state, remains unity when a subsequent second one of said plurality of

successive sets of image data is in said active data state and becomes zero

when a further subsequent third one of said plurality of successive sets of

image data is in said inactive data state, and

15

said second scaling factor has a value which is initially zero, becomes

unity when said subsequent second one of said plurality of successive sets of

image data is in said active data state and remains unity thereafter.

According to a still further aspect of the present invention there is

provided a method of providing X-ray image signals having selectable spatial

20

resolutions in a still image mode or an image motion mode including correcting

for defective pixels individually or in groups, including the steps of:

receiving a plurality of detector control signals and in accordance therewith

receiving and converting a plurality of X-ray photons into a first plurality of image

25



signals, wherein

said plurality of X-ray photons correspond to a two-dimensional image represented by a first two-dimensional array which includes a first plurality of rows and a first plurality of columns of pixels which together correspond to
 5 said two-dimensional image and which individually correspond to respective portions of said two-dimensional image, and

said first plurality of image signals represent a second two-dimensional array which includes a second plurality of rows and said first plurality of columns of pixels which selectively represent respective individual ones
 10 or multiple adjacent ones of said first plurality of rows of pixels and respective individual ones of said first plurality of columns of pixels, respectively;

receiving a plurality of receiver control signals and in accordance therewith receiving and combining said first plurality of image signals and in accordance
 15 therewith generating a second plurality of image signals which represent a third two-dimensional array including said second plurality of rows and a second plurality of columns of super pixels which selectively represent respective individual ones of said second plurality of rows of super pixels and respective individual ones or multiple adjacent ones of said first plurality of columns of super pixels, respectively;

receiving and processing together said second plurality of image signals with a
 20 corresponding plurality of successive sets of correction data and in accordance therewith generating a plurality of successive sets of corrected image data, wherein said plurality of successive sets of correction data represents a plurality of correction



factors, each one of said plurality of correction factors corresponds to a respective one of said plurality of super pixels and each one of said plurality of successive sets of correction data includes a first data subset which indicates whether said respective one of said plurality of super pixels is defective;

5 selecting between individual ones of said plurality of successive sets of corrected image data and individual ones of said corresponding plurality of successive sets of correction data and in accordance therewith generating a first plurality of successive sets of selected data, wherein an individual one of said first plurality of successive sets of selected data includes a corresponding individual one of said
10 plurality of successive sets of correction data when said first data subset indicates that said corresponding respective one of said plurality of pixels is defective, and wherein said individual one of said first plurality of successive sets of selected data includes a corresponding one of said plurality of successive sets of corrected image data when said first data subset does not indicate that said corresponding respective one of said
15 plurality of pixels is defective;

 receiving and scaling said first plurality of successive sets of selected data, receiving and scaling a stored data sum signal and summing said scaled first plurality of successive sets of selected data and said scaled stored data sum signal and in accordance therewith generating a data sum signal, wherein said first plurality of
20 successive sets of selected data is scaled in accordance with a first scaling factor and said stored data sum signal is scaled in accordance with a second scaling factor, and wherein said first plurality of successive sets of selected data includes a plurality of successive sets of image data, and further wherein each one of said plurality of

25



successive sets of image data includes a plurality of super pixel data with active and inactive data states and which corresponds to said third two-dimensional array; and

selectively storing said data sum signal and in accordance therewith generating said stored data sum signal;

5 wherein said step of receiving and scaling said first plurality of successive sets of selected data, receiving and scaling a stored data sum signal and summing said scaled first plurality of successive sets of selected data and said scaled stored data sum signal and in accordance therewith generating a data sum signal and said step of selectively storing said data sum signal and in accordance therewith generating said
10 stored data sum signal are cooperatively performed in one of a plurality of performance modes during said reception of said first plurality of successive sets of selected data;

wherein, in a first one of said plurality of performance modes,

said first scaling factor has a value which is between zero and unity,

and

said second scaling factor has a value which equals a difference between unity and said first scaling factor value; and

wherein, in a second one of said plurality of performance modes,

said first scaling factor has a value which is initially unity when a first
20 one of said plurality of successive sets of image data is in said inactive data state, remains unity when a subsequent second one of said plurality of successive sets of image data is in said active data state and becomes zero when a further subsequent third one of said plurality of successive sets of



image data is in said inactive data state, and

said second scaling factor has a value which is initially zero, becomes unity when said subsequent second one of said plurality of successive sets of image data is in said active data state and remains unity thereafter.

5 According to a still further aspect of the present invention there is provided a method of providing X-ray image signals having selectable spatial resolutions, including the steps of:

receiving a plurality of detector control signals and in accordance therewith:

10 receiving and converting a plurality of X-ray photons which correspond to a two-dimensional image into a first plurality of image signals which represent a first two-dimensional array including a first plurality of rows and a first plurality of columns of pixels which together correspond to said two-dimensional image and which individually correspond to respective portions of said two-dimensional image, and

15 generating a second plurality of image signals which represent a second two-dimensional array including a second plurality of rows and said first plurality of columns of pixels which selectively represent respective individual ones or multiple adjacent ones of said first plurality of rows of pixels and respective individual ones of said first plurality of columns of pixels, respectively; and

20 receiving a plurality of receiver control signals and in accordance therewith receiving and combining said second plurality of image signals and in accordance therewith generating a third plurality of image signals which represent a third two-

25



dimensional array including said second plurality of rows and a second plurality of columns of super pixels which selectively represent respective individual ones of said second plurality of rows of super pixels and respective individual ones or multiple adjacent ones of said first plurality of columns of super pixels, respectively;

5 wherein said second and third pluralities of image signals comprise first and second pluralities of electrical charges, respectively; and

 said step of receiving a plurality of receiver control signals and in accordance therewith receiving and combining said second plurality of image signals and in accordance therewith generating a third plurality of image signals comprises receiving
10 a portion of said plurality of receiver control signals and in accordance therewith receiving and capacitively combining selected ones of said first plurality of electrical charges and in accordance therewith generating said second plurality of electrical charges.

 According to a still further aspect of the present invention there is
15 provided a method of providing X-ray image signals having selectable spatial resolutions, including the steps of:

 receiving a plurality of detector control signals and in accordance therewith receiving and converting a plurality of X-ray photons into a first plurality of image signals, wherein:

20 said plurality of X-ray photons correspond to a two-dimensional image represented by a first two-dimensional array which includes a first plurality of rows and a first plurality of columns of pixels which together correspond to said two-dimensional image and which individually correspond to respective portions of said two-dimensional image, and

25 said first plurality of image signals represent a second two-dimensional array which includes a second plurality of rows and said first plurality of



columns of pixels which selectively represent respective individual ones or multiple adjacent ones of said first plurality of rows of pixels and respective individual ones of said first plurality of columns of pixels, respectively;

5

receiving a plurality of receiver control signals and in accordance therewith receiving and combining said first plurality of image signals and in accordance therewith generating a second plurality of image signals which represent a third two-dimensional array including said second plurality of rows and a second plurality of columns of super pixels which selectively represent respective individual ones of said second plurality of rows of super pixels and respective individual ones or multiple adjacent ones of said first plurality of columns of super pixels, respectively;

10

wherein said first and second pluralities of image signals comprise first and second pluralities of electrical charges, respectively; and

15

said step of receiving a plurality of receiver control signals and in accordance therewith receiving and combining said first plurality of image signals and in accordance therewith generating a second plurality of image signals comprises receiving a portion of said plurality of receiver control signals and in accordance therewith receiving and capacitively combining selected ones of said first plurality of electrical charges and in accordance therewith generating said second plurality of electrical charges.

20

According to a still further aspect of the present invention there is provided a method of processing a serial stream of multiple bit data sets which represent an array of pixels corresponding to a two-dimensional image including correcting for defective pixels individually or in groups, including the steps of:

25

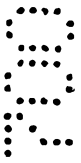
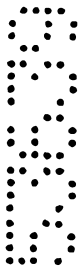

receiving and processing together a plurality of successive sets of image data with a corresponding plurality of successive sets of correction data and in accordance therewith generating a plurality of successive sets of corrected image data, wherein said plurality of successive sets of image data represents a plurality of pixels

5 corresponding to a two-dimensional image, said plurality of successive sets of correction data represents a plurality of correction factors, each one of said plurality of correction factors corresponds to a respective one of said plurality of pixels and each one of said plurality of successive sets of correction data includes a first data subset which indicates whether said respective one of said plurality of pixels is

10 defective; and

receiving and selecting between individual ones of said plurality of successive sets of corrected image data and individual ones of said corresponding plurality of successive sets of correction data and in accordance therewith generating a first plurality of successive sets of selected data, wherein an individual one of said first

15 plurality of successive sets of selected data includes a corresponding individual one of said plurality of successive sets of correction data when said first data subset indicates that said corresponding respective one of said plurality of pixels is defective, and wherein said individual one of said first plurality of successive sets of selected data includes a corresponding one of said plurality of successive sets of corrected image

20 data when said first data subset does not indicate that said corresponding respective one of said plurality of pixels is defective.

According to a still further aspect of the present invention there is provided a method of selectively storing image pixel data, combining new incoming image pixel data with previously stored image pixel data and providing

25 such combined image pixel data for display thereof in a still image mode or an image motion mode, including the steps of:

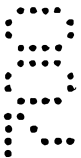

receiving and scaling an input data signal, receiving and scaling a stored data sum signal and summing said scaled input data signal and said scaled stored data sum signal and in accordance therewith generating a data sum signal, wherein said input data signal is scaled in accordance with a first scaling factor and said stored data sum signal is scaled in accordance with a second scaling factor, and wherein said input data signal includes a plurality of successive sets of image data, and further wherein each one of said plurality of successive sets of image data includes a plurality of pixel data with active and inactive data states and which corresponds to a two-dimensional image having a two-dimensional array including a plurality of rows and a plurality of columns of pixels which together correspond to said two-dimensional image and which individually correspond to respective portions of said two-dimensional image; and

receiving and selectively storing said data sum signal and in accordance therewith generating said stored data sum signal;

wherein said step of receiving and scaling an input data signal, receiving and scaling a stored data sum signal and summing said scaled input data signal and said scaled stored data sum signal and in accordance therewith generating a data sum signal and said step of receiving and selectively storing said data sum signal and in accordance therewith generating said stored data sum signal are cooperatively performed in one of a plurality of performance modes during said reception of said input data signal;

wherein, in a first one of said plurality of performance modes,

said first scaling factor has a value which is between zero and unity,

and

said second scaling factor has a value which equals a difference between unity and said first scaling factor value; and

25



wherein, in a second one of said plurality of performance modes,

said first scaling factor has a value which is initially unity when a first one of said plurality of successive sets of image data is in said inactive data state, remains unity when a subsequent second one of said plurality of successive sets of image data is in said active data state and becomes zero when a further subsequent third one of said plurality of successive sets of image data is in said inactive data state, and

said second scaling factor has a value which is initially zero, becomes unity when said subsequent second one of said plurality of successive sets of image data is in said active data state and remains unity thereafter.

The combining of pixel information collected by the detector array, i.e., "pixel binning", may be performed by selectively combining one portion of the pixel information within the detector array and selectively combining the remainder of the pixel information within the circuits fed by the output of the detector array. Such pixel binning is preferably analog in nature and is performed prior to any digitizing of the pixel signals, thereby providing for a higher SNR, and, importantly, reducing the bandwidth requirements for the digital electronics. More specifically, a multiple mode X-ray detector system for supporting multiple X-ray image display modes by providing X-ray image signals having selectable spatial resolutions may include a detector array and a group of detector array receiver circuits. The detector array may be configured to receive a group of detector control signals and in accordance therewith receive and convert X-ray photons corresponding to a two-dimensional image into a first group of image signals representing a first two-dimensional array which includes a first group of rows and a first group of columns of pixels which together correspond to the two-dimensional image and which individually correspond to respective portions of the two-dimensional image. The detector array may provide, in accordance with the detector control signals, a second group of image signals representing a second two-dimensional array which includes a second group of rows and the first group of columns of super pixels which selectively represent respective individual ones or multiple adjacent ones of the first group of rows of pixels and respective individual ones of the first group of columns of pixels, respectively. The detector array receiver circuits,

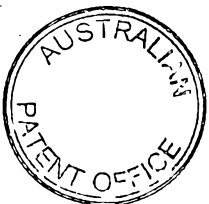
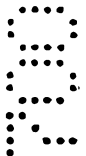
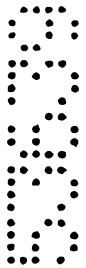

coupled to the detector array, are configured to receive a group of receiver control signals and in accordance therewith receive and combine the second group of image signals and in accordance therewith provide a third plurality of image signals representing a third two-dimensional array which includes the second group of rows and a second group of columns of super pixels which selectively represent respective individual ones of the second group of rows of super pixels and respective individual ones or multiple adjacent ones of the first group of columns of super pixels, respectively.

Data flags may be used to identify defective pixels within the detector array and are inserted into the data stream collected from the detector array for dynamic processing along with the pixel data. More specifically, a data processing system for processing a serial stream of multiple bit data sets which represent an array of pixels corresponding to a two-dimensional image including correcting for defective pixels individually or in groups may include a data processing circuit and a data selection circuit. The data processing circuit may be configured to receive and process together a plurality of successive sets of image data with a corresponding plurality of successive sets of correction data and in accordance therewith provide a plurality of successive sets of corrected image data. The plurality of successive sets of image data may represent a plurality of pixels corresponding to a two-dimensional image, the plurality of successive sets of correction data may represent a plurality of correction factors, each one of the plurality of correction factors corresponds to a respective one of the plurality of pixels and each one of the plurality of successive sets of correction data may include a data subset which indicates whether the respective one of the plurality of pixels is defective. The data selection circuit, coupled to the data processing circuit, may be configured to receive and select between individual ones of the plurality of successive sets of corrected image data and individual ones of the corresponding plurality of successive sets of correction data and in accordance therewith provide a plurality of successive sets of selected data. An individual one of the plurality of successive sets of selected data may include a corresponding individual one of the plurality of successive sets of correction data when the data subset indicates that the corresponding respective one of the plurality of pixels is defective, and the individual one of the plurality of successive sets of selected

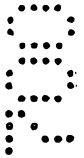
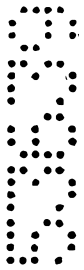

data may include a corresponding one of the plurality of successive sets of corrected image data when the data subset does not indicate that the corresponding respective one of the plurality of pixels is defective.

5 A data buffer and filter may be used to perform still image capture during radiographic imaging and to recursively filter incoming image data during fluoroscopic imaging. More specifically, a digital data buffer and filter for selectively storing image pixel data, combining new incoming image pixel data with previously stored image pixel data and providing such combined image pixel data for display thereof in a still image mode or an image motion mode 10 may include a data scaling and summing circuit and a data memory circuit. The data scaling and summing circuit may be configured to receive and scale an input data signal, receive and scale a stored data sum signal and sum said scaled input data signal and said scaled stored data sum signal and in accordance therewith provide a data sum signal. The input data signal may be 15 scaled in accordance with a first scaling factor and the stored data sum signal may be scaled in accordance with a second scaling factor. The input data signal may include a plurality of successive sets of image data, and each one of the plurality of successive sets of image data may include a plurality of pixel data with active and inactive data states and which corresponds to a two-dimensional image having a two-dimensional array including a plurality of rows and a plurality of columns of pixels which together correspond to the two-dimensional image and which individually correspond to respective portions of the two-dimensional image. The data memory circuit, coupled to the data scaling and summing circuit, may be configured to receive and selectively store 20 the data sum signal and provide the stored data sum signal. The data scaling and summing circuit and the data memory circuit may cooperatively operate in one of a plurality of operational modes during reception of the plurality of successive sets of image data. In a first one of the plurality of operational modes (e.g., in fluoroscopic mode), the first scaling factor may have a value which is between zero and unity, and the second scaling factor may have a value which equals a difference between unity and the first scaling factor value. In a second one of the plurality of operational modes (e.g., in radiographic mode): the first scaling factor may have a value which is initially unity when a first one of the plurality of successive sets of image data is in the inactive data 30

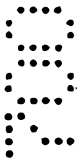

state, may remain unity when a subsequent second one of the plurality of successive sets of image data is in the active data state and may become zero when a further subsequent third one of the plurality of successive sets of image data is in the inactive data state; and the second scaling factor may have a value which is initially zero, become unity when the subsequent second one of the plurality of successive sets of image data is in the active data state and remain unity thereafter.

BRIEF DESCRIPTION OF THE DRAWINGS

Preferred embodiments of the present invention will now be described with reference to the accompanying drawings wherein:

15

20

25

30

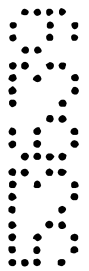

Figure 1 is a functional block diagram of an X-ray imaging system in accordance with the present invention.

Figure 2 is an exploded perspective view of an X-ray detector cassette for an X-ray imaging system in accordance with the present invention.

5 Figure 3 is a schematic diagram of a portion of the detector array of Figure 2.

Figure 4 is a functional block diagram of the array driver circuit assemblies of Figure 2.

Figure 5 is a functional block diagram of the receiver circuit assembly of Figure 2.

10 Figure 6 is a functional block diagram of the readout circuits in the receiver circuit assembly of Figure 5.

Figure 7 is a simplified schematic diagram of several adjacent preamplifier circuits in the readout circuit of Figure 6.

Figure 8 is a functional block diagram of the portion of the computer and control system of Figure 1 in which the image data is processed for display in accordance with the selected mode of operation.

Figure 9 represents the format of the data correction instruction word used by the decode/select and pixel data averaging stages of Figure 8.

Figure 10 illustrates an example of how the grouping of defective pixels within the detector array determines the selection of north/south or east/west pixel data averaging.

20 Figure 11 is a functional block diagram of the pixel data averaging stages of Figure 8.

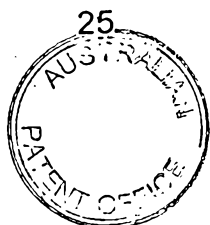

Figure 12 is a functional block diagram of the data buffer stage of Figure 8.

Figure 13 is a timing diagram illustrating the relative timing and values of the data scaling factors during a radiographic mode of operation.

Figure 14 is a functional block diagram of an alternative embodiment of the data
5 buffer stage of Figure 8.

DETAILED DESCRIPTION OF THE INVENTION

Referring to Figure 1, an X-ray imaging system 10 in accordance with the present invention includes a detector cassette 12, a computer and control system 14, a user interface
10 16, a fluoroscopic display 18a and a radiographic display 18b, interconnected substantially as shown. A user controls the system 10 by way of a user interface 16 (e.g., graphical user interface display, keyboard, mouse, etc.) which communicates with the computer and control system 14. Accordingly, the computer and control system 14 generates control signals 13a for the detector cassette 12 which provides image data signals 13b in return. (As desired,
15 one display monitor could be used to selectively display both fluoroscopic and radiographic images, as well as the graphical user interface display image, e.g., all images could be displayed simultaneously in a "windowed" format, or either a fluoroscopic image or a radiographic image could be displayed along with a pull down menu bar, which menu bar constitutes the graphical user interface providing for selection of fluoroscopic or radiographic
20 imaging.)

Following processing of such image data, the computer and control system 14 provides fluoroscopic image data 15a or radiographic image data 15b for display on a fluoroscopic display 18a or a radiographic display 18b, respectively, depending upon the

selected mode of operation. The fluoroscopic display 18a preferably employs a phosphor which has a relatively short persistence time, thereby reducing unwanted ghost images when observing motion in the sequence of displayed images. The radiographic display 18b preferably employs a phosphor which yields a bluish tint to gray levels and has a relatively long persistence time, thereby replicating the bluish tint typically found in standard medical X-ray film images and reducing unwanted flicker in the displayed image.

Referring to Figure 2, the detector cassette 12 is similar in external appearance to the typical cassette which contains standard medical X-ray film and is, therefore, highly mobile and easy to use as required for a radiographic mode of operation. A scintillation layer 20, e.g., of cesium iodide (CsI), absorbs and converts impinging X-ray photons to visible light photons for detection by photosensitive elements within the detector array 22, e.g., of amorphous silicon (a-Si). The thickness of the scintillation layer 20 is selected so as to absorb sufficient X-ray photons and produce sufficient visible photons so as to generate an adequate SNR for fluoroscopic operation. Similarly, the columns, or "needles," of the crystalline CsI are selected so as to have diameters sufficiently small to support the spatial resolution sampling desired for radiographic operation.

The detector array 22 is designed in accordance with well known techniques into a two dimensional array of microscopic squares referred to as picture elements, or "pixels." Each pixel is composed of an addressable photosensitive element, such as a photodiode and switching transistor combination. As discussed in more detail below, each pixel is accessed in accordance with drive signals from off-array driver circuit assemblies 26a, 26b which provide addressing control signals. In accordance with well known techniques, the lateral dimensions of the photodiodes are made sufficiently small to provide the desired spatial

resolution imaging for radiographic operation and the capacitance of the photodiodes is designed to be sufficiently large to provide the desired signal handling capacity for accommodating the largest signal produced during radiographic operation.

The pixel data accessed by the driver circuits 26 are read out by a receiver, or
5 readout, circuit assembly 28, as discussed in more detail below. The receiver circuit assembly 28 and detector array 22 are mounted on opposing sides of a base plate 24. (The receiver circuit assembly 28 is placed beneath the array 22 so as to minimize the lateral size of the detector cassette 12 and thereby make the detector cassette 12 approximately the same size as a film cassette. If so desired, the driver circuits 26 can also be placed beneath the
10 array 22.)

Referring to Figure 3, the detector array 22, as noted above, is composed of a two dimensional array, or matrix, of photosensitive pixels 30 which, in a preferred embodiment, include a switching transistor 32 and a photodiode 34. The anode of the photodiode 34 is biased by a biasing voltage 35 to establish a capacitance for storing electrical charges which
15 accumulate due to the reception of incident light 21 from the scintillation layer 20 (Figure 2). When the pixel 30 is accessed, a row address signal 31 from the array driver circuit 26 (discussed in more detail below) drives the gate of the switching transistor 32 (TFT), thereby providing a column data signal 33 representing the stored charge from the photodiode 34. This signal 33 is received and buffered by a charge sensitive amplifier within the receiver
20 circuit assembly 28 (discussed in more detail below).

Each row address signal 31 is asserted for a predetermined period of time, referred to as "line time." During assertion of each row address signal 31, the signal 33 from each pixel along that row is transmitted via the column data lines to the receiver circuit assembly

28 where the signal 33 on each data line is received and buffered by a corresponding charge sensitive amplifier (discussed in more detail below). Hence, an entire row of image data is captured in one line time period. With each subsequent line time period, a subsequent row of image data is captured. At the end of a "frame time" period, the entire image has been
5 captured. In this manner, each pixel contained in the entire active detection area is sampled individually.

Based upon the foregoing, and in accordance with the more detailed discussions of the driver 26 and receiver 28 circuit assemblies which follow, it can be seen that the pixel array supports multiple modes of operation. For example, during radiographic operation,
10 the pixel data is sampled on a pixel-by-pixel basis as discussed above. However, during fluoroscopic operation, pixel data access can be accelerated, albeit with a reduction in spatial resolution. This can be done by combining, or "binning," multiple pixels to produce "super pixels." For example, a two-by-two pixel subset in which two rows and columns of pixels are combined can be created by addressing two adjacent rows and two adjacent columns of
15 pixels at one time, with the driver circuit assembly 26 performing the simultaneous row addressing and the receiver circuit assembly 28 performing the column line signal combining. Hence, while the spatial resolution is reduced accordingly, significantly less time will be required to capture the image, thereby allowing fluoroscopic imaging to be performed.

20 This use of super pixels can also be done in a more selective manner. For example, image acquisition in a fluoroscopic magnification mode can be performed when only a portion of the active detection area is of interest. During such operation, the rows outside the region of interest are addressed at a rapid rate or skipped entirely, while the rows within

the region of interest are addressed at a slower rate. The overall time to sequence through or skip past all of the rows, i.e., the frame time, can remain equal to the frame time associated with the fluoroscopic normal mode. However, due to the increased time available within the region of interest, the super pixels within such region can be reduced in size, thereby

5 increasing the spatial resolution. (Appropriate combining of column line signals is also used accordingly.) Hence, the smaller the size of the super pixel in the region of interest, the higher the apparent magnification. (A smaller area of the detector is captured when operating in fluoroscopic magnification mode than when operating in fluoroscopic normal mode, but the display area remains the same, thereby producing an apparent magnification.)

10 Referring to Figure 4, the driver circuit assembly 26 includes a local controller 40 for receiving control signals 13aa from the computer and control system 14 (Figure 1), plus a series of gate drivers 42 for providing the row addressing signals 31. These gate drivers 42 can be operated in the manner of shift registers or, alternatively, be individually programmed as desired according to the mode of operation using the control signals 41 from

15 the local controller 40. For example, during radiographic operation, the driver circuits 42 can be programmed such that the row 1 addressing signal 31(1) is asserted while the remaining row addressing signals are de-asserted. Immediately following the next line synchronization cycle, the row 1 signal is de-asserted and the row 2 signal is asserted, while the remaining row signals are de-asserted. This successive assertion and de-assertion of

20 signals is repeated until all rows have been addressed. During fluoroscopic operation, the foregoing assertion and de-assertion sequence is repeated, with the exception that multiple adjacent row address signals are asserted at one time for creating super pixels, as discussed above.

Referring to Figure 5, the receiver circuit assembly 28 includes a local controller 50 for receiving control signals 13ab from the computer and control system 14 (Figure 1) and generating local control signals 51. In accordance with its local control signals 51a, a number of readout circuits 52 (discussed in more detail below), the number of which
5 depends upon the number of columns to be read out from the detector array 22, receives the column data signals 33. The outputs 53 from the readout circuits 52 are buffered by respective transimpedance amplifiers 54. These transimpedance amplifiers 54 are controlled by local control signals 51b for purposes of controlling their offset and gain characteristics (discussed in more detail below). The buffered column data signals 55 are converted by
10 analog-to-digital converters (ADCs) 56. The resulting digitized column data signals 57 are then multiplexed by a multiplexor. The resulting multiplexed data signals 59 are buffered by a data transmitter 60 for transmission to the computer and control system 14.

The control signals 51b for the transimpedance amplifiers 54 are used to selectively optimize the offset and gain characteristics of the amplifiers 54. This allows the amplifiers
15 54 to be biased to match the respective output signal ranges of the amplifiers 54 to the input signal ranges of the corresponding ADCs 56.

Referring to Figure 6, the readout circuits 52 collectively include multiple input preamplifiers 64, pipelined sample and hold circuits 66 and output multiplexors 68, interconnected substantially as shown. The control signals 51a from the local controller 50
20 (Figure 5) control the preamplifiers 64, pipelined sample and hold circuits 66 and a multiplexor controller 62 which, in turn, controls the multiplexors 68 via multiplexor control signals 63. The preamplifiers 64 receive the column data signals 33 with charge sensitive amplifiers and provide the aforementioned binning capability for creating super pixels (in

conjunction with the multiple row addressing capability of the array driver circuit 26 (Figure 4) as discussed above). The charge sensitive amplifiers are discussed in more detail in copending, commonly assigned U.S. patent application no. 08/758,538, entitled "Charge Sensitive Amplifier With High Common Mode Signal Rejection," filed November 29, 1996, the disclosure of which is incorporated herein by reference. (The pixel binning capability provided by the preamplifiers is discussed in more detail below in connection with Figure 7.)

The buffered output signals 65aa, 65ba, 65ca, from the preamplifiers 64, are sampled using correlated double sampling by the pipelined sample and hold circuits 66 in accordance with their respective control signals 51ab. These pipelined sample and hold circuits 66 are described in more detail in copending, commonly assigned U.S. patent application no. 08/758,536, entitled "Pipelined Sample and Hold Circuit With Correlated Double Sampling," filed November 29, 1996, the disclosure of which is incorporated herein by reference.

The sampled data signals 67 are multiplexed by their respective multiplexors 68 to provide the final output signal 53. These multiplexors 68 operate in an analog current mode and are described in more detail in copending, commonly assigned U.S. patent application no. 08/758,528, entitled "Current Mode Analog Signal Multiplexor," November 29, 1996, the disclosure of which is incorporated herein by reference.

Referring to Figure 7, the aforementioned pixel binning capability with respect to the column data can be described as follows. For purposes of this explanation, the second 64b, third 64c and fourth 64d preamplifier circuits are illustrated to represent the interconnection among adjacent preamplifiers 64. Internal to each preamplifier 64 is the aforementioned charge sensitive amplifier 70 which receives the column data signal 33. The buffered

column data signal 71 is coupled by a series coupling capacitor 72 to a summing node 78 for selectively being summed with the buffered and capacitively coupled column data signal from its adjacent preamplifier circuit 64. For example, if one-by-two super pixels were being used, then the third and fourth pixels would be binned together by appropriately asserting and de-asserting the control signals in signal sets 51aac and 51aad (and their inverse equivalents via inverters 80c and 80d) so that switches 74c, 74e and 76d are opened and switches 74d and 76c are closed. Accordingly, the buffered and capacitively coupled data signal 65db from the fourth preamplifier 64d is summed with that of the third preamplifier 64c at its summing mode 78c for outputting as binned pixel data signal 65ca.

10 Referring to Figure 8, that portion 14a of the computer and control system 14 (Figure 1) responsible for processing the image data for display in accordance with the selected mode of operation functions as follows. The sampled image data 13ba from the detector cassette 12 (Figure 1) is detected by a data detection stage 100. The data detection stage 100 monitors selected portions of the frame of incoming data and, in addition to passing the incoming data 101a on to the next stage, generates a data present status signal 101b for use elsewhere within the system (as discussed in more detail below).

The buffered sampled image data 101a is corrected by an offset and gain correction stage 104 using offset and gain correction data 103b, 103c stored in a memory 102. Such offset and gain correction data 103b, 103c can be acquired in accordance with well known techniques. For example, the offset correction data, used to correct for the effects of leakage currents within the detector array 22 (Figure 2), can be collected by processing dark frames of pixel data (no X-ray photons received) and inputted as a portion of pixel mapped data 103a to the memory 102. The gain correction data, used for normalizing the gain

profile of the detector array 22, can be collected by processing frames of pixel data generated when receiving an unobstructed X-ray field, and inputted as a portion of pixel mapped data 103a to the memory 102. Such data is used to correct for variations in pixel quantum efficiency and the two dimensional gain profile of the detector array 22 together
5 with its associated receiver circuitry 28.

In addition to the offset and gain information, one of the correction data words 103c (e.g., corresponding to that normally used for gain correction data) also includes pixel flag data and pixel data averaging instruction bits which identify, on a pixel-by-pixel basis, which
10 pixels, if any, are defective and the nature of such defect and, therefore, require the use of either north/south or east/west averaging. Such pixel flag data can be collected in accordance with well known techniques. For example, defective pixels can be identified
while collecting the offset and/or gain correction data.

Referring to Figure 9, the format of the correction data word 103c corresponding to a bad pixel is as shown. (It should be understood that other selected bits within the word 103c
15 can be used, as desired). The most significant bit is used to identify the state of the pixel, i.e., whether the pixel represents valid data or is defective and, therefore, represents invalid data. Other bits, e.g., bits 10 and 5, are used to indicate whether north/south or east/west averaging is to be performed. When the pixel data flag identifies the pixel as containing
valid data, the remaining bits contain the actual offset or gain correction information to be
20 used by the offset and gain correction stage 104.

Referring to Figure 10, the decision criteria for determining whether north/south or east/west pixel data averaging is to be performed can be explained as follows. In this example, a group of four defective pixels DP1-DP4 have been identified in columns X-1

through X+1 and rows Y-1 and Y, as shown. For this configuration of defective pixels, the data correction words 103c corresponding to these defective pixels, in addition to containing asserted pixel flags identifying these pixels as being defective, will contain asserted north/south and east/west averaging instruction bits. For defective pixels DP2 and DP4, a north/south averaging will be performed using the pixel data immediately above and below in columns X-1 and X+1. Since this portion of columns X-1 and X+1 contain "good" pixel data, the defective pixels DP1 and DP3 will be processed using east/west averaging. It is preferred that an east/west average be followed by a north/south and thereafter followed by a second east/west average to allow different arrangements of defective pixels to be corrected.

10 Referring again to Figure 8, the offset and gain correction stage 104 processes the incoming data 101a on a pixel-by-pixel basis in accordance with the correction data 103b, 103c regardless of whether any such data is identified as originating from a bad pixel. The resulting corrected data 105 is then provided, along with the one correction data word 103c to a decode/select circuit 106. If, according to the pixel flag data within the correction data word 103c from the memory 102, the corrected pixel data 105 did not originate from a defective pixel, the decode/select circuit 106 provides the corrected pixel data 105 as its output signal 107. If, however, the pixel flag data identify the "corrected data" 105 as having originated from a defective pixel, the decode/select circuit 106 provides the correction data 103c from the memory 102 as its output signal 107 for dynamic processing along with other valid corrected pixel data by the remainder of this processing section 14a.

20 The data 107 from the decode/select stage 106 is then processed, in accordance with the north/south and east/west averaging instruction bits discussed above, by a north/south averaging circuit 108 or an east/west averaging circuit 110. For example, if the selected

data 107 contains an instruction bit identifying north/south averaging as being required, the north/south averaging stage 108 produces appropriately averaged data 109 which is then simply passed through the east/west averaging stage 110 without further processing.

However, if the selected data 107 contains an instruction bit identifying east/west averaging as being required, the selected data 107 is simply passed through the north/south averaging stage 108 and presented to the east/west averaging stage 110 for appropriate processing therein.

Referring to Figure 11, the averaging function performed by the north/south 108 and east/west 110 averaging stages can be described as follows. The incoming data 107/109 is inputted continuously to a delay line 120 (e.g., a shift register). For the north/south averaging stage 108, this delay line 120 is large enough to contain slightly more than two rows of pixel data, while for the east/west averaging stage 110, the delay line 120 need only be large enough to accommodate three or more pixels worth of data. When a data word 107/109 containing an asserted averaging instruction bit which corresponds to that particular averaging stage 108/110 is encountered, it is provided as an output signal 121a to a decode/select stage 124 when it has reached the approximate midpoint of the delay line 120.

Upon receiving this signal 121a, the decode/select stage 124, recognizing the instruction, uses the averaged pixel data 123 provided by a data averaging stage 122. (The data averaging operation performed by this stage 122 can be done in accordance with any of several well known techniques, e.g., interpolation of selected adjacent pixel data.) If, however, this midpoint signal 121a from the delay line 120 does not contain an asserted averaging instruction bit, but, instead, simply contains normal pixel data, the decode/select stage 124 will ignore the averaged pixel data 123 constantly being provided by the data

averaging stage 122 and simply provide this pixel data signal 121a as its output data signal 109/111.

Referring again to Figure 8, the final averaged pixel data 111 is then selectively processed by a data buffer/filter 112. The operation of this data buffer filter 112 for the different modes of operation can be explained as follows with reference to Figures 12 and 13. A preferred embodiment 112a of the data buffer/filter 112 includes an adder 130, a memory (e.g., random access memory) 132, two scaling circuits (e.g., multipliers) 134, 136, and two data registers 138, 140. The memory 132 is used to continuously receive and store the output data 113 on a frame-by-frame basis and provide such stored data in a first-in, first-out manner to one of the scaling circuits 136. The data registers 138, 140 contain data corresponding to scaling factors α and β for scaling the present pixel data 111 and corresponding prior pixel data 133 (i.e., from a previous frame), respectively. The data registers 138, 140 use the aforementioned data present status signal 101b, a mode control signal 17a (originating from within the computer and control system 14) and an α/β programming signal 149 for establishing the values of the α 139 and β 141 data provided to the scaling circuits 134, 136. The mode control signal 17a identifies whether a still or motion image operation is to be performed, while the α/β programming signal 149 can be used to program the actual values for α and β .

When operating in a still image (e.g., radiographic) mode, the α data 139 and β data 141 are initialized at unity and zero, respectively. When the data present status signal 101b indicates that valid active data has begun being received, the β data 141 is switched from zero to unity. Accordingly, scaled data sets 135 and 137 are equal to the present frame pixel data 111 and prior frame pixel data 133, respectively, thereby resulting in frame summation.

This summation of prior and present frames of pixel data is done to generate the complete data set for display and is necessary since all data associated with a still image is generally not captured in a single reading of one frame of data, as represented in Figure 13. Once the data present status signal 101b has indicated that valid active data is no longer being
5 received, and after one additional frame of data has been collected, the α data 138 is reset to zero, while the β data 141 remains at unity.

When operating in a motion image (e.g., fluoroscopic) mode, the present data frame scaling factor α 137 is set equal to a predetermined value between zero and unity. Such a value can be established empirically to provide a video display with the desired
10 characteristics. The prior data frame scaling factor β 141 is set at a value which is also between zero and unity and is equal to $1-\alpha$. Hence, the output data 113 to be used for display purposes is composed primarily of the present frame of pixel data summed with a small portion of the prior frame of pixel data as stored by the memory 132. This has the effect of slightly increasing the SNR of the displayed frame as compared to the frame as
15 captured by the detector array 22. (Also, it has the additional effect of smoothing out any observable motion within the displayed image).

Referring again to Figure 8, the buffered and/or filtered pixel data 113 is used to address a lookup table 114 for purposes of mapping the input pixel data 113 to pixel data 15a/15b which is appropriately scaled for the particular display device being used.
20 Alternatively, this output stage 114 can include additional circuitry, as desired, to provide actual video signals for directly driving a display monitor.

Referring to Figure 14, an alternative embodiment 112b of the data buffer/filter stage 112 can be implemented as shown. (Those elements which correspond to those in the

embodiment 112a of Figure 12 are identified with the same numeric designators.) This
embodiment 112b can be used where the α and β scaling factor data has been inserted or
encoded in some manner within the incoming data stream 111. Accordingly, a shift register
150 can be used to buffer and delay the actual pixel data while the α data 151a and β data
5 151b are removed and forwarded on to the scaling circuits 134, 136. An encode logic
circuit 152 can be used to provide appropriate control signals 153, in accordance with the
mode control signal 17a, to the shift register 150.

Various other modifications and alterations in the structure and method of operation
of this invention will be apparent to those skilled in the art without departing from the scope
10 and spirit of the invention. Although the invention has been described in connection with
specific preferred embodiments, it should be understood that the invention as claimed should
not be unduly limited to such specific embodiments. It is intended that the following claims
define the scope of the present invention and that structures and methods within the scope of
these claims and their equivalents be covered thereby.

THE CLAIMS DEFINING THE INVENTION ARE AS FOLLOWS:

1. An apparatus including a multiple mode X-ray imaging system for supporting multiple X-ray image display modes by providing X-ray image signals having selectable spatial resolutions in a still image mode or an image motion mode with correction for

5 defective pixels individually or in groups, including:

a detector array configured to receive a plurality of detector control signals and in accordance therewith

10 receive and convert a plurality of X-ray photons corresponding to a two-dimensional image into a first plurality of image signals representing a first two-dimensional array which includes a first plurality of rows and a first plurality of columns of pixels which together correspond to said two-dimensional image and which individually correspond to respective portions of said two-dimensional image, and

15 provide a second plurality of image signals representing a second two-dimensional array which includes a second plurality of rows and said first plurality of columns of pixels which selectively represent respective individual ones or multiple adjacent ones of said first plurality of rows of pixels and respective individual ones of said first plurality of columns of pixels, respectively;

20 a plurality of detector array receiver circuits, coupled to said detector array, configured to receive a plurality of receiver control signals and in accordance therewith receive and combine said second plurality of image signals and in accordance therewith provide a third plurality of image signals representing a third

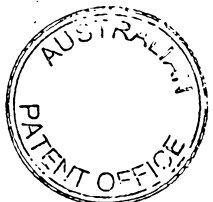
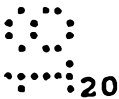
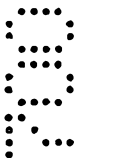
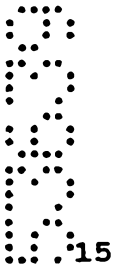

two-dimensional array which includes said second plurality of rows and a second plurality of columns of super pixels which selectively represent respective individual ones of said second plurality of rows of super pixels and respective individual ones or multiple adjacent ones of said first plurality of columns of super pixels, respectively;

5 a first data processing circuit, coupled to said plurality of detector array receiver circuits, configured to receive and process together said third plurality of image signals with a corresponding plurality of successive sets of correction data and in accordance therewith provide a plurality of successive sets of corrected image data, wherein said plurality of successive sets of correction data represents a plurality of
10 correction factors, each one of said plurality of correction factors corresponds to a respective one of said plurality of super pixels and each one of said plurality of successive sets of correction data includes a first data subset which indicates whether said respective one of said plurality of super pixels is defective;

a first data selection circuit, coupled to said first data processing circuit,
15 configured to receive and select between individual ones of said plurality of successive sets of corrected image data and individual ones of said corresponding plurality of successive sets of correction data and in accordance therewith provide a first plurality of successive sets of selected data, wherein an individual one of said first plurality of successive sets of selected data includes a corresponding individual
20 one of said plurality of successive sets of correction data when said first data subset indicates that said corresponding respective one of said plurality of pixels is defective, and wherein said individual one of said first plurality of successive sets of selected data includes a corresponding one of said plurality of successive sets of

corrected image data when said first data subset does not indicate that said
corresponding respective one of said plurality of pixels is defective;

a data scaling and summing circuit, coupled to said first data selection circuit,
configured to receive and scale said first plurality of successive sets of selected data,
5 receive and scale a stored data sum signal and sum said scaled first plurality of
successive sets of selected data and said scaled stored data sum signal and in
accordance therewith provide a data sum signal, wherein said first plurality of
successive sets of selected data is scaled in accordance with a first scaling factor and
said stored data sum signal is scaled in accordance with a second scaling factor, and
10 wherein said first plurality of successive sets of selected data includes a plurality of
successive sets of image data, and further wherein each one of said plurality of
successive sets of image data includes a plurality of super pixel data with active and
inactive data states and which corresponds to said third two-dimensional array; and

a data memory circuit, coupled to said data scaling and summing circuit,
15 configured to receive and selectively store said data sum signal and in accordance
therewith provide said stored data sum signal;

wherein said data scaling and summing circuit and said data memory circuit
cooperatively operate in one of a plurality of operational modes during said reception
of said first plurality of successive sets of selected data;

20 wherein, in a first one of said plurality of operational modes,

said first scaling factor has a value which is between zero and unity,

and

said second scaling factor has a value which equals a difference

between unity and said first scaling factor value; and

wherein, in a second one of said plurality of operational modes,

said first scaling factor has a value which is initially unity when a first one of said plurality of successive sets of image data is in said inactive data state, remains unity when a subsequent second one of said plurality of successive sets of image data is in said active data state and becomes zero when a further subsequent third one of said plurality of successive sets of image data is in said inactive data state, and

said second scaling factor has a value which is initially zero, becomes unity when said subsequent second one of said plurality of successive sets of image data is in said active data state and remains unity thereafter.

2. An apparatus including a multiple mode X-ray detector system for supporting multiple X-ray image display modes by providing X-ray image signals having selectable spatial resolutions, including:

a detector array configured to receive a plurality of detector control signals and in accordance therewith

receive and convert a plurality of X-ray photons corresponding to a two-dimensional image into a first plurality of image signals representing a first two-dimensional array which includes a first plurality of rows and a first plurality of columns of pixels which together correspond to said two-dimensional image and which individually correspond to respective portions of said two-dimensional image, and

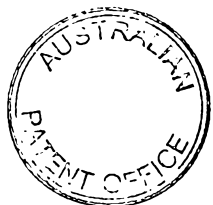

provide a second plurality of image signals representing a second two-dimensional array which includes a second plurality of rows and said first plurality of columns of pixels which selectively represent respective individual ones or multiple adjacent ones of said first plurality of rows of pixels and respective individual ones of said first plurality of columns of pixels, respectively; and

a plurality of detector array receiver circuits, coupled to said detector array, configured to receive a plurality of receiver control signals and in accordance therewith receive and combine said second plurality of image signals and in

accordance therewith provide a third plurality of image signals representing a third two-dimensional array which includes said second plurality of rows and a second plurality of columns of super pixels which selectively represent respective individual ones of said second plurality of rows of super pixels and respective individual ones or multiple adjacent ones of said first plurality of columns of super pixels, respectively;

wherein said plurality of detector array receiver circuits comprises a plurality of capacitive switching circuits configured to receive a portion of said plurality of receiver control signals and in accordance therewith receive and combine selected ones of said second plurality of image signals and in accordance therewith provide said third plurality of image signals.

3. The apparatus of claim 2, wherein said detector array comprises a two-dimensional array of a plurality of pixel elements, and wherein each one of said plurality of pixel elements comprises a light sensitive circuit configured to:

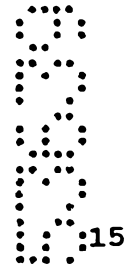

receive one of said plurality of detector control signals and in accordance therewith receive and convert a portion of said plurality of X-ray photons into one of said first plurality of image signals; and

receive another one of said plurality of detector control signals and said one of said first plurality of image signals and in accordance therewith provide one of said second plurality of image signals.

5 4. The apparatus of claim 3, wherein said light sensitive circuit comprises:

10 a photodiode configured to receive said one of said plurality of detector control signals and in accordance therewith receive and convert said portion of said plurality of X-ray photons into one of said first plurality of image signals; and

15 a switching transistor, coupled to said photodiode, configured to receive said another one of said plurality of detector control signals and said one of said first plurality of image signals and in accordance therewith provide one of said second plurality of image signals.

5. The apparatus of claim 2, further comprising a plurality of sample and hold circuits, coupled to said plurality of capacitive switching circuits, configured to receive another portion of said plurality of receiver control signals and in accordance therewith sample and hold said second plurality of electrical charges.

6. The apparatus of claim 2, further comprising a plurality of detector array driver circuits, coupled to said detector array, configured to receive a plurality of driver control

signals and in accordance therewith provide said plurality of detector control signals.

7. The apparatus of claim 6, wherein said plurality of detector array driver circuits comprises a plurality of demultiplexors configured to receive a portion of said plurality of driver control signals and in accordance therewith provide a plurality of row addressing signals as a portion of said plurality of detector control signals.

8. An apparatus including a data processing system for processing a serial stream of multiple bit data sets which represent an array of pixels corresponding to a two-dimensional image including correcting for defective pixels individually or in groups, including:

a first data processing circuit configured to receive and process together a plurality of successive sets of image data with a corresponding plurality of successive sets of correction data and in accordance therewith provide a plurality of successive sets of corrected image data, wherein said plurality of successive sets of image data represents a plurality of pixels corresponding to a two-dimensional image, said plurality of successive sets of correction data represents a plurality of correction factors, each one of said plurality of correction factors corresponds to a respective one of said plurality of pixels and each one of said plurality of successive sets of correction data includes a first data subset which indicates whether said respective one of said plurality of pixels is defective; and

a first data selection circuit, coupled to said first data processing circuit, configured to receive and select between individual ones of said plurality of successive sets of corrected image data and individual ones of said corresponding



plurality of successive sets of correction data and in accordance therewith provide a first plurality of successive sets of selected data, wherein an individual one of said first plurality of successive sets of selected data includes a corresponding individual one of said plurality of successive sets of correction data when said first data subset indicates that said corresponding respective one of said plurality of pixels is defective, and wherein said individual one of said first plurality of successive sets of selected data includes a corresponding one of said plurality of successive sets of corrected image data when said first data subset does not indicate that said corresponding respective one of said plurality of pixels is defective.

10

9. The apparatus of claim 8, wherein each one of said plurality of successive sets of correction data further includes a second data subset which indicates which one of a plurality of substitute pixel values is to be used for said defective corresponding respective one of said plurality of pixels, and further comprising:

15

a second data processing circuit, coupled to said first data selection circuit, configured to receive and store said first plurality of successive sets of selected data and generate a first set of substitute data, wherein said first set of substitute data represents a first one of said plurality of substitute pixel values and is computed in accordance with selected ones of said stored first plurality of successive sets of selected data; and

20

a second data selection circuit, coupled to said second data processing circuit, configured to receive and select between one of said stored first plurality of successive sets of selected data and said first set of substitute data and in accordance

therewith provide a second plurality of successive sets of selected data, wherein an individual one of said second plurality of successive sets of selected data includes said first set of substitute data when said second data subset indicates that said first one of said plurality of substitute pixel values is to be used for said defective corresponding
5 respective one of said plurality of pixels, and wherein said individual one of said second plurality of successive sets of selected data includes said one of said stored first plurality of successive sets of selected data when said second data subset does not indicate that said first one of said plurality of substitute pixel values is to be used for said defective corresponding respective one of said plurality of pixels.

10

10. The apparatus of claim 9, wherein said second data processing circuit comprises:

a delay line configured to receive and store said first plurality of successive sets of selected data and in accordance therewith provide a plurality of successively delayed sets of selected data, wherein a temporally intermediate one of said plurality
15 of successively delayed sets of selected data is provided as said one of said stored first plurality of successive sets of selected data; and

a data averaging circuit, coupled to said delay line, configured to receive and average first and second ones of said plurality of successively delayed sets of selected data and in accordance therewith provide said first set of substitute data, wherein said
20 first and second ones of said plurality of successively delayed sets of selected data are temporally precedent and subsequent to said temporally intermediate one of said plurality of successively delayed sets of selected data.

11. The apparatus of claim 9, further comprising:

a third data processing circuit, coupled to said second data selection circuit, configured to receive and store said second plurality of successive sets of selected data and generate a second set of substitute data, wherein said second set of substitute data represents a second one of said plurality of substitute pixel values and is computed in accordance with selected ones of said stored second plurality of successive sets of selected data; and

5

10

15

20

a third data selection circuit, coupled to said third data processing circuit, configured to receive and select between one of said stored second plurality of successive sets of selected data and said second set of substitute data and in accordance therewith provide a third plurality of successive sets of selected data, wherein an individual one of said third plurality of successive sets of selected data includes said second set of substitute data when said second data subset indicates that said second one of said plurality of substitute pixel values is to be used for said defective corresponding respective one of said plurality of pixels, and wherein said individual one of said third plurality of successive sets of selected data includes said one of said stored second plurality of successive sets of selected data when said second data subset does not indicate that said second one of said plurality of substitute pixel values is to be used for said defective corresponding respective one of said plurality of pixels.

12. The apparatus of claim 8, further comprising a data storage circuit, coupled to said first data processing circuit and said first data selection circuit, configured to store and

provide said corresponding plurality of successive sets of correction data.

13. An apparatus including a digital data buffer and filter for selectively storing image pixel data, combining new incoming image pixel data with previously stored image pixel data and providing such combined image pixel data for display thereof in a still image mode
5 or an image motion mode, including:

a data scaling and summing circuit configured to receive and scale an input data signal, receive and scale a stored data sum signal and sum said scaled input data signal and said scaled stored data sum signal and in accordance therewith provide a data sum signal, wherein said input data signal is scaled in accordance with a first
10 scaling factor and said stored data sum signal is scaled in accordance with a second scaling factor, and wherein said input data signal includes a plurality of successive sets of image data, and further wherein each one of said plurality of successive sets of image data includes a plurality of pixel data with active and inactive data states and which corresponds to a two-dimensional image having a two-dimensional array
15 including a plurality of rows and a plurality of columns of pixels which together correspond to said two-dimensional image and which individually correspond to respective portions of said two-dimensional image; and

a data memory circuit, coupled to said data scaling and summing circuit,
20 configured to receive and selectively store said data sum signal and in accordance therewith provide said stored data sum signal;

wherein said data scaling and summing circuit and said data memory circuit cooperatively operate in one of a plurality of operational modes during said reception



of said input data signal;

wherein, in a first one of said plurality of operational modes,

said first scaling factor has a value which is between zero and unity,

and

5 said second scaling factor has a value which equals a difference

between unity and said first scaling factor value; and

wherein, in a second one of said plurality of operational modes,

said first scaling factor has a value which is initially unity when a first

one of said plurality of successive sets of image data is in said inactive data

10 state, remains unity when a subsequent second one of said plurality of

successive sets of image data is in said active data state and becomes zero

when a further subsequent third one of said plurality of successive sets of

image data is in said inactive data state, and

said second scaling factor has a value which is initially zero, becomes

15 unity when said subsequent second one of said plurality of successive sets of

image data is in said active data state and remains unity thereafter.

14. The apparatus of claim 13, wherein said data scaling and summing circuit comprises
an arithmetic logic unit.

20

15. The apparatus of claim 13, wherein said data scaling and summing circuit comprises:

a first data scaling circuit configured to receive a first scaling control signal

which represents said first scaling factor and in accordance therewith receive and

scale said input data signal and in accordance therewith provide a first scaled data signal;

a second data scaling circuit configured to receive a second scaling control signal which represents said second scaling factor and in accordance therewith receive
5 and scale said stored data sum signal and in accordance therewith provide a second scaled data signal; and

a data summing circuit, coupled to said first and second data scaling circuits, configured to receive and sum said first and second scaled data signals and in accordance therewith provide said data sum signal.

10

16. The apparatus of claim 13, wherein said data memory circuit comprises a random access memory unit.

17. The apparatus of claim 15, further comprising first and second control signal sources
15 configured to provide said first and second scaling control signals.

18. The apparatus of claim 15, further comprising a signal separator circuit configured to receive an incoming data signal and separate therefrom said first and second scaling control signals and in accordance therewith provide said input data signal and said first and second
20 scaling control signals.

19. An apparatus including a multiple mode X-ray imaging system for supporting multiple X-ray image display modes by providing X-ray image signals having selectable

spatial resolutions in a still image mode or an image motion mode including correcting for defective pixels individually or in groups, including:

a detector array configured to receive a plurality of detector control signals and in accordance therewith receive and convert a plurality of X-ray photons into a first plurality of image signals, wherein

said plurality of X-ray photons correspond to a two-dimensional image represented by a first two-dimensional array which includes a first plurality of rows and a first plurality of columns of pixels which together correspond to said two-dimensional image and which individually correspond to respective portions of said two-dimensional image, and

said first plurality of image signals represent a second two-dimensional array which includes a second plurality of rows and said first plurality of columns of pixels which selectively represent respective individual ones or multiple adjacent ones of said first plurality of rows of pixels and respective individual ones of said first plurality of columns of pixels, respectively;

a plurality of detector array receiver circuits, coupled to said detector array, configured to receive a plurality of receiver control signals and in accordance therewith receive and combine said first plurality of image signals and in accordance therewith provide a second plurality of image signals representing a third two-dimensional array which includes said second plurality of rows and a second plurality of columns of super pixels which selectively represent respective individual ones of said second plurality of rows of super pixels and respective individual ones or



15

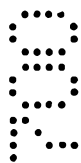

20



multiple adjacent ones of said first plurality of columns of super pixels, respectively;

a first data processing circuit, coupled to said plurality of detector array receiver circuits, configured to receive and process together said second plurality of image signals with a corresponding plurality of successive sets of correction data and
5 in accordance therewith provide a plurality of successive sets of corrected image data, wherein said plurality of successive sets of correction data represents a plurality of correction factors, each one of said plurality of correction factors corresponds to a respective one of said plurality of super pixels and each one of said plurality of successive sets of correction data includes a first data subset which indicates whether
10 said respective one of said plurality of super pixels is defective;

a first data selection circuit, coupled to said first data processing circuit, configured to receive and select between individual ones of said plurality of successive sets of corrected image data and individual ones of said corresponding plurality of successive sets of correction data and in accordance therewith provide a
15 first plurality of successive sets of selected data, wherein an individual one of said first plurality of successive sets of selected data includes a corresponding individual one of said plurality of successive sets of correction data when said first data subset indicates that said corresponding respective one of said plurality of pixels is defective, and wherein said individual one of said first plurality of successive sets of
20 selected data includes a corresponding one of said plurality of successive sets of corrected image data when said first data subset does not indicate that said corresponding respective one of said plurality of pixels is defective;

a data scaling and summing circuit, coupled to said first data selection circuit,

configured to receive and scale said first plurality of successive sets of selected data, receive and scale a stored data sum signal and sum said scaled first plurality of successive sets of selected data and said scaled stored data sum signal and in accordance therewith provide a data sum signal, wherein said first plurality of

5 successive sets of selected data is scaled in accordance with a first scaling factor and said stored data sum signal is scaled in accordance with a second scaling factor, and wherein said first plurality of successive sets of selected data includes a plurality of successive sets of image data, and further wherein each one of said plurality of successive sets of image data includes a plurality of super pixel data with active and
10 inactive data states and which corresponds to said third two-dimensional array; and

a data memory circuit, coupled to said data scaling and summing circuit, configured to receive and selectively store said data sum signal and in accordance therewith provide said stored data sum signal;

wherein said data scaling and summing circuit and said data memory circuit
15 cooperatively operate in one of a plurality of operational modes during said reception of said first plurality of successive sets of selected data;

wherein, in a first one of said plurality of operational modes,

said first scaling factor has a value which is between zero and unity,

and

20 said second scaling factor has a value which equals a difference between unity and said first scaling factor value; and

wherein, in a second one of said plurality of operational modes,

said first scaling factor has a value which is initially unity when a first

one of said plurality of successive sets of image data is in said inactive data state, remains unity when a subsequent second one of said plurality of successive sets of image data is in said active data state and becomes zero when a further subsequent third one of said plurality of successive sets of image data is in said inactive data state, and

5

said second scaling factor has a value which is initially zero, becomes unity when said subsequent second one of said plurality of successive sets of image data is in said active data state and remains unity thereafter.

10 20. A method of providing X-ray image signals having selectable spatial resolutions in a still image mode or an image motion mode including correcting for defective pixels individually or in groups, including the steps of:

receiving a plurality of detector control signals and in accordance therewith:

receiving and converting a plurality of X-ray photons which correspond to a two-dimensional image into a first plurality of image signals which represent a first two-dimensional array including a first plurality of rows and a first plurality of columns of pixels which together correspond to said two-dimensional image and which individually correspond to respective portions of said two-dimensional image, and

generating a second plurality of image signals which represent a second two-dimensional array including a second plurality of rows and said first plurality of columns of pixels which selectively represent respective individual ones or multiple adjacent ones of said first plurality of rows of

15

15

20



pixels and respective individual ones of said first plurality of columns of pixels, respectively; and

receiving a plurality of receiver control signals and in accordance therewith receiving and combining said second plurality of image signals and in accordance
5 therewith generating a third plurality of image signals which represent a third two-dimensional array including said second plurality of rows and a second plurality of columns of super pixels which selectively represent respective individual ones of said second plurality of rows of super pixels and respective individual ones or multiple adjacent ones of said first plurality of columns of super pixels, respectively;

10 receiving and processing together said third plurality of image signals with a corresponding plurality of successive sets of correction data and in accordance therewith generating a plurality of successive sets of corrected image data, wherein said plurality of successive sets of correction data represents a plurality of correction factors, each one of said plurality of correction factors corresponds to a respective
15 one of said plurality of super pixels and each one of said plurality of successive sets of correction data includes a first data subset which indicates whether said respective one of said plurality of super pixels is defective;

selecting between individual ones of said plurality of successive sets of corrected image data and individual ones of said corresponding plurality of successive
20 sets of correction data and in accordance therewith generating a first plurality of successive sets of selected data, wherein an individual one of said first plurality of successive sets of selected data includes a corresponding individual one of said plurality of successive sets of correction data when said first data subset indicates that

said corresponding respective one of said plurality of pixels is defective, and wherein said individual one of said first plurality of successive sets of selected data includes a corresponding one of said plurality of successive sets of corrected image data when said first data subset does not indicate that said corresponding respective one of said plurality of pixels is defective;

5 receiving and scaling said first plurality of successive sets of selected data, receiving and scaling a stored data sum signal and summing said scaled first plurality of successive sets of selected data and said scaled stored data sum signal and in accordance therewith generating a data sum signal, wherein said first plurality of

10 successive sets of selected data is scaled in accordance with a first scaling factor and said stored data sum signal is scaled in accordance with a second scaling factor, and wherein said first plurality of successive sets of selected data includes a plurality of successive sets of image data, and further wherein each one of said plurality of successive sets of image data includes a plurality of super pixel data with active and

15 inactive data states and which corresponds to said third two-dimensional array; and selectively storing said data sum signal and in accordance therewith generating said stored data sum signal;

wherein said step of receiving and scaling said first plurality of successive sets of selected data, receiving and scaling a stored data sum signal and summing said

20 scaled first plurality of successive sets of selected data and said scaled stored data sum signal and in accordance therewith generating a data sum signal and said step of selectively storing said data sum signal and in accordance therewith generating said stored data sum signal are cooperatively performed in one of a plurality of

performance modes during said reception of said first plurality of successive sets of selected data;

wherein, in a first one of said plurality of performance modes,

said first scaling factor has a value which is between zero and unity,

5 and

said second scaling factor has a value which equals a difference between unity and said first scaling factor value; and

wherein, in a second one of said plurality of performance modes,

10 said first scaling factor has a value which is initially unity when a first one of said plurality of successive sets of image data is in said inactive data state, remains unity when a subsequent second one of said plurality of

successive sets of image data is in said active data state and becomes zero

when a further subsequent third one of said plurality of successive sets of image data is in said inactive data state, and

15 said second scaling factor has a value which is initially zero, becomes unity when said subsequent second one of said plurality of successive sets of image data is in said active data state and remains unity thereafter.

20 21. A method of providing X-ray image signals having selectable spatial resolutions in a still image mode or an image motion mode including correcting for defective pixels individually or in groups, including the steps of:

receiving a plurality of detector control signals and in accordance therewith receiving and converting a plurality of X-ray photons into a first plurality of image



signals, wherein

said plurality of X-ray photons correspond to a two-dimensional image represented by a first two-dimensional array which includes a first plurality of rows and a first plurality of columns of pixels which together correspond to said two-dimensional image and which individually correspond to respective portions of said two-dimensional image, and

said first plurality of image signals represent a second two-dimensional array which includes a second plurality of rows and said first plurality of columns of pixels which selectively represent respective individual ones or multiple adjacent ones of said first plurality of rows of pixels and respective individual ones of said first plurality of columns of pixels, respectively;

receiving a plurality of receiver control signals and in accordance therewith receiving and combining said first plurality of image signals and in accordance therewith generating a second plurality of image signals which represent a third two-dimensional array including said second plurality of rows and a second plurality of columns of super pixels which selectively represent respective individual ones of said second plurality of rows of super pixels and respective individual ones or multiple adjacent ones of said first plurality of columns of super pixels, respectively;

receiving and processing together said second plurality of image signals with a corresponding plurality of successive sets of correction data and in accordance therewith generating a plurality of successive sets of corrected image data, wherein said plurality of successive sets of correction data represents a plurality of correction



15

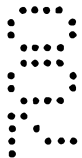

20

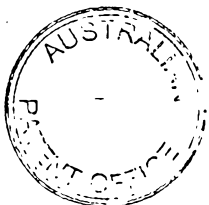

factors, each one of said plurality of correction factors corresponds to a respective one of said plurality of super pixels and each one of said plurality of successive sets of correction data includes a first data subset which indicates whether said respective one of said plurality of super pixels is defective;

5 selecting between individual ones of said plurality of successive sets of corrected image data and individual ones of said corresponding plurality of successive sets of correction data and in accordance therewith generating a first plurality of successive sets of selected data, wherein an individual one of said first plurality of successive sets of selected data includes a corresponding individual one of said
10 plurality of successive sets of correction data when said first data subset indicates that said corresponding respective one of said plurality of pixels is defective, and wherein said individual one of said first plurality of successive sets of selected data includes a corresponding one of said plurality of successive sets of corrected image data when said first data subset does not indicate that said corresponding respective one of said
15 plurality of pixels is defective;

 receiving and scaling said first plurality of successive sets of selected data, receiving and scaling a stored data sum signal and summing said scaled first plurality of successive sets of selected data and said scaled stored data sum signal and in
20 accordance therewith generating a data sum signal, wherein said first plurality of successive sets of selected data is scaled in accordance with a first scaling factor and said stored data sum signal is scaled in accordance with a second scaling factor, and wherein said first plurality of successive sets of selected data includes a plurality of successive sets of image data, and further wherein each one of said plurality of

successive sets of image data includes a plurality of super pixel data with active and inactive data states and which corresponds to said third two-dimensional array; and

selectively storing said data sum signal and in accordance therewith generating said stored data sum signal;

5 wherein said step of receiving and scaling said first plurality of successive sets of selected data, receiving and scaling a stored data sum signal and summing said scaled first plurality of successive sets of selected data and said scaled stored data sum signal and in accordance therewith generating a data sum signal and said step of selectively storing said data sum signal and in accordance therewith generating said
10 stored data sum signal are cooperatively performed in one of a plurality of performance modes during said reception of said first plurality of successive sets of selected data;

wherein, in a first one of said plurality of performance modes,

said first scaling factor has a value which is between zero and unity,

15 and

said second scaling factor has a value which equals a difference between unity and said first scaling factor value; and

wherein, in a second one of said plurality of performance modes,

said first scaling factor has a value which is initially unity when a first
20 one of said plurality of successive sets of image data is in said inactive data state, remains unity when a subsequent second one of said plurality of successive sets of image data is in said active data state and becomes zero when a further subsequent third one of said plurality of successive sets of

image data is in said inactive data state, and

said second scaling factor has a value which is initially zero, becomes unity when said subsequent second one of said plurality of successive sets of image data is in said active data state and remains unity thereafter.

5

22. A method of providing X-ray image signals having selectable spatial resolutions, including the steps of:

receiving a plurality of detector control signals and in accordance therewith:

receiving and converting a plurality of X-ray photons which

10 correspond to a two-dimensional image into a first plurality of image signals which represent a first two-dimensional array including a first plurality of rows and a first plurality of columns of pixels which together correspond to said two-dimensional image and which individually correspond to respective portions of said two-dimensional image, and

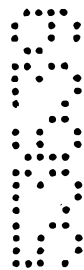

15

generating a second plurality of image signals which represent a second two-dimensional array including a second plurality of rows and said first plurality of columns of pixels which selectively represent respective individual ones or multiple adjacent ones of said first plurality of rows of pixels and respective individual ones of said first plurality of columns of pixels, respectively; and

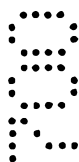

20

receiving a plurality of receiver control signals and in accordance therewith receiving and combining said second plurality of image signals and in accordance therewith generating a third plurality of image signals which represent a third two-

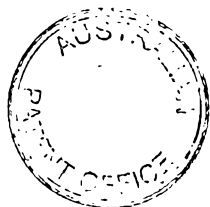

dimensional array including said second plurality of rows and a second plurality of columns of super pixels which selectively represent respective individual ones of said second plurality of rows of super pixels and respective individual ones or multiple adjacent ones of said first plurality of columns of super pixels, respectively;

5 wherein said second and third pluralities of image signals comprise first and second pluralities of electrical charges, respectively; and

 said step of receiving a plurality of receiver control signals and in accordance therewith receiving and combining said second plurality of image signals and in accordance therewith generating a third plurality of image signals comprises receiving
10 a portion of said plurality of receiver control signals and in accordance therewith receiving and capacitively combining selected ones of said first plurality of electrical charges and in accordance therewith generating said second plurality of electrical charges.

15 23. The method of claim 22, wherein said method of providing X-ray image signals having selectable spatial resolutions comprises providing said X-ray image signals by using a two-dimensional array of a plurality of pixel elements, and wherein for each one of said plurality of pixel elements:

 said step of receiving a plurality of detector control signals and in accordance
20 therewith receiving and converting a plurality of X-ray photons into a first plurality of image signals comprises receiving one of said plurality of detector control signals and in accordance therewith receiving and converting a portion of said plurality of X-ray photons into one of said first plurality of image signals; and

said step of receiving a plurality of detector control signals and in accordance therewith generating a second plurality of image signals comprises receiving another one of said plurality of detector control signals and said one of said first plurality of image signals and in accordance therewith generating one of said second plurality of image signals.

5

24. A method of providing X-ray image signals having selectable spatial resolutions, including the steps of:

receiving a plurality of detector control signals and in accordance therewith receiving and converting a plurality of X-ray photons into a first plurality of image signals, wherein:

10

said plurality of X-ray photons correspond to a two-dimensional image represented by a first two-dimensional array which includes a first plurality of rows and a first plurality of columns of pixels which together correspond to said two-dimensional image and which individually correspond to respective portions of said two-dimensional image, and

15

said first plurality of image signals represent a second two-dimensional array which includes a second plurality of rows and said first plurality of columns of pixels which selectively represent respective individual ones or multiple adjacent ones of said first plurality of rows of pixels and respective individual ones of said first plurality of columns of pixels, respectively;

20

receiving a plurality of receiver control signals and in accordance therewith

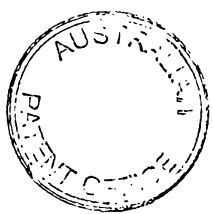
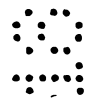
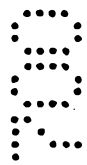
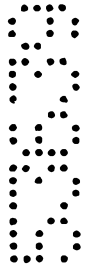

receiving and combining said first plurality of image signals and in accordance therewith generating a second plurality of image signals which represent a third two-dimensional array including said second plurality of rows and a second plurality of columns of super pixels which selectively represent
5
respective individual ones of said second plurality of rows of super pixels and respective individual ones or multiple adjacent ones of said first plurality of columns of super pixels, respectively;

wherein said first and second pluralities of image signals comprise first and second pluralities of electrical charges, respectively; and

10
said step of receiving a plurality of receiver control signals and in accordance therewith receiving and combining said first plurality of image signals and in accordance therewith generating a second plurality of image signals comprises receiving a portion of said plurality of receiver control signals and in accordance therewith receiving and capacitively combining selected ones of said first plurality of
15
electrical charges and in accordance therewith generating said second plurality of electrical charges.

25. The method of claim 24, wherein said method of providing X-ray image signals having selectable spatial resolutions comprises providing said X-ray image signals by using a
20
two-dimensional array of a plurality of pixel elements, and wherein for each one of said plurality of pixel elements said step of receiving a plurality of detector control signals and in accordance therewith receiving and converting a plurality of X-ray photons into a first plurality of image signals comprises receiving a portion of said plurality of detector control

signals and in accordance therewith receiving and converting a portion of said plurality of X-ray photons into one of said first plurality of image signals.

26. A method of processing a serial stream of multiple bit data sets which represent an array of pixels corresponding to a two-dimensional image including correcting for defective pixels individually or in groups, including the steps of:

receiving and processing together a plurality of successive sets of image data with a corresponding plurality of successive sets of correction data and in accordance therewith generating a plurality of successive sets of corrected image data, wherein said plurality of successive sets of image data represents a plurality of pixels corresponding to a two-dimensional image, said plurality of successive sets of correction data represents a plurality of correction factors, each one of said plurality of correction factors corresponds to a respective one of said plurality of pixels and each one of said plurality of successive sets of correction data includes a first data subset which indicates whether said respective one of said plurality of pixels is defective; and

receiving and selecting between individual ones of said plurality of successive sets of corrected image data and individual ones of said corresponding plurality of successive sets of correction data and in accordance therewith generating a first plurality of successive sets of selected data, wherein an individual one of said first plurality of successive sets of selected data includes a corresponding individual one of said plurality of successive sets of correction data when said first data subset indicates that said corresponding respective one of said plurality of pixels is defective, and



wherein said individual one of said first plurality of successive sets of selected data includes a corresponding one of said plurality of successive sets of corrected image data when said first data subset does not indicate that said corresponding respective one of said plurality of pixels is defective.

5

27. The method of claim 26, wherein each one of said plurality of successive sets of correction data further includes a second data subset which indicates which one of a plurality of substitute pixel values is to be used for said defective corresponding respective one of said plurality of pixels, and further comprising the steps of:

10

receiving and storing said first plurality of successive sets of selected data and generating a first set of substitute data, wherein said first set of substitute data represents a first one of said plurality of substitute pixel values and is computed in accordance with selected ones of said stored first plurality of successive sets of selected data; and

15

receiving and selecting between one of said stored first plurality of successive sets of selected data and said first set of substitute data and in accordance therewith generating a second plurality of successive sets of selected data, wherein an individual one of said second plurality of successive sets of selected data includes said first set of substitute data when said second data subset indicates that said first one of said plurality of substitute pixel values is to be used for said defective corresponding respective one of said plurality of pixels, and wherein said individual one of said second plurality of successive sets of selected data includes said one of said stored first plurality of successive sets of selected data when said second data subset does

20

not indicate that said first one of said plurality of substitute pixel values is to be used for said defective corresponding respective one of said plurality of pixels.

28. The method of claim 27, wherein said step of receiving and storing said first plurality
5 of successive sets of selected data and generating a first set of substitute data comprises:

receiving and storing said first plurality of successive sets of selected data and
in accordance therewith generating a plurality of successively delayed sets of selected
data, wherein a temporally intermediate one of said plurality of successively delayed
sets of selected data is outputted as said one of said stored first plurality of successive
10 sets of selected data; and

receiving and averaging first and second ones of said plurality of successively
delayed sets of selected data and in accordance therewith generating said first set of
substitute data, wherein said first and second ones of said plurality of successively
delayed sets of selected data are temporally precedent and subsequent to said
15 temporally intermediate one of said plurality of successively delayed sets of selected
data.

29. The method of claim 27, further comprising the steps of:

receiving and storing said second plurality of successive sets of selected data
20 and generating a second set of substitute data, wherein said second set of substitute
data represents a second one of said plurality of substitute pixel values and is
computed in accordance with selected ones of said stored second plurality of
successive sets of selected data; and

receiving and selecting between one of said stored second plurality of successive sets of selected data and said second set of substitute data and in accordance therewith generating a third plurality of successive sets of selected data, wherein an individual one of said third plurality of successive sets of selected data includes said second set of substitute data when said second data subset indicates that said second one of said plurality of substitute pixel values is to be used for said defective corresponding respective one of said plurality of pixels, and wherein said individual one of said third plurality of successive sets of selected data includes said one of said stored second plurality of successive sets of selected data when said second data subset does not indicate that said second one of said plurality of substitute pixel values is to be used for said defective corresponding respective one of said plurality of pixels.

30. A method of selectively storing image pixel data, combining new incoming image pixel data with previously stored image pixel data and providing such combined image pixel data for display thereof in a still image mode or an image motion mode, including the steps of:

receiving and scaling an input data signal, receiving and scaling a stored data sum signal and summing said scaled input data signal and said scaled stored data sum signal and in accordance therewith generating a data sum signal, wherein said input data signal is scaled in accordance with a first scaling factor and said stored data sum signal is scaled in accordance with a second scaling factor, and wherein said input data signal includes a plurality of successive sets of image data, and further wherein



15

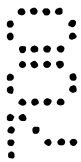

20



each one of said plurality of successive sets of image data includes a plurality of pixel data with active and inactive data states and which corresponds to a two-dimensional image having a two-dimensional array including a plurality of rows and a plurality of columns of pixels which together correspond to said two-dimensional image and which individually correspond to respective portions of said two-dimensional image; and

receiving and selectively storing said data sum signal and in accordance therewith generating said stored data sum signal;

wherein said step of receiving and scaling an input data signal, receiving and scaling a stored data sum signal and summing said scaled input data signal and said scaled stored data sum signal and in accordance therewith generating a data sum signal and said step of receiving and selectively storing said data sum signal and in accordance therewith generating said stored data sum signal are cooperatively performed in one of a plurality of performance modes during said reception of said input data signal;

wherein, in a first one of said plurality of performance modes,

said first scaling factor has a value which is between zero and unity,

and

said second scaling factor has a value which equals a difference between unity and said first scaling factor value; and

wherein, in a second one of said plurality of performance modes,

said first scaling factor has a value which is initially unity when a first one of said plurality of successive sets of image data is in said inactive data

state, remains unity when a subsequent second one of said plurality of successive sets of image data is in said active data state and becomes zero when a further subsequent third one of said plurality of successive sets of image data is in said inactive data state, and

5 said second scaling factor has a value which is initially zero, becomes unity when said subsequent second one of said plurality of successive sets of image data is in said active data state and remains unity thereafter.

31. The method of claim 30, wherein said step of receiving and scaling an input data
10 signal, receiving and scaling a stored data sum signal and summing said scaled input data signal and said scaled stored data sum signal and in accordance therewith generating a data sum signal comprises:

 receiving a first scaling control signal which represents said first scaling factor
 and in accordance therewith receiving and scaling said input data signal and in
15 accordance therewith generating a first scaled data signal;

 receiving a second scaling control signal which represents said second scaling
 factor and in accordance therewith receiving and scaling said stored data sum signal
 and in accordance therewith generating a second scaled data signal; and

 receiving and summing said first and second scaled data signals and in
20 accordance therewith generating said data sum signal.

32. The method of claim 31, further comprising the step of receiving an incoming data
 signal and separating therefrom said first and second scaling control signals and in

accordance therewith generating said input data signal and said first and second scaling control signals.

33. An apparatus for supporting multiple X-ray image display modes
5 substantially as hereinbefore described with reference to the accompanying drawings.

34. A method for providing X-ray image signals substantially as hereinbefore described with reference to the accompanying drawings.

10

DATED: 18 July 2000

PHILLIPS ORMONDE & FITZPATRICK

Patent Attorneys for:

15 VARIAN MEDICAL SYSTEMS, INC.

PHILLIPS

ORMONDE

FITZPATRICK



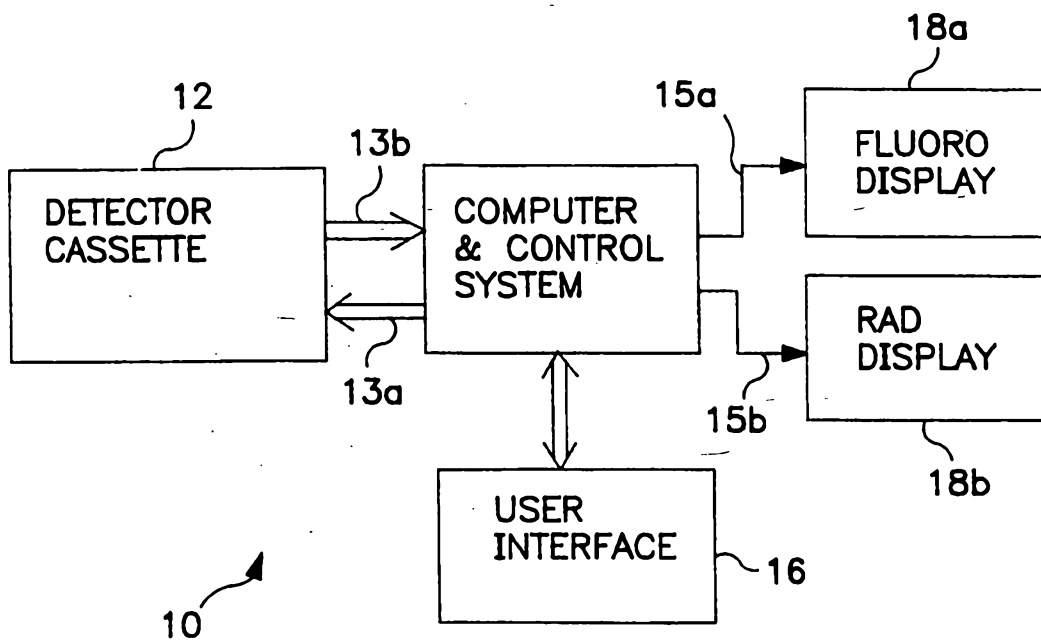

FIG. 1

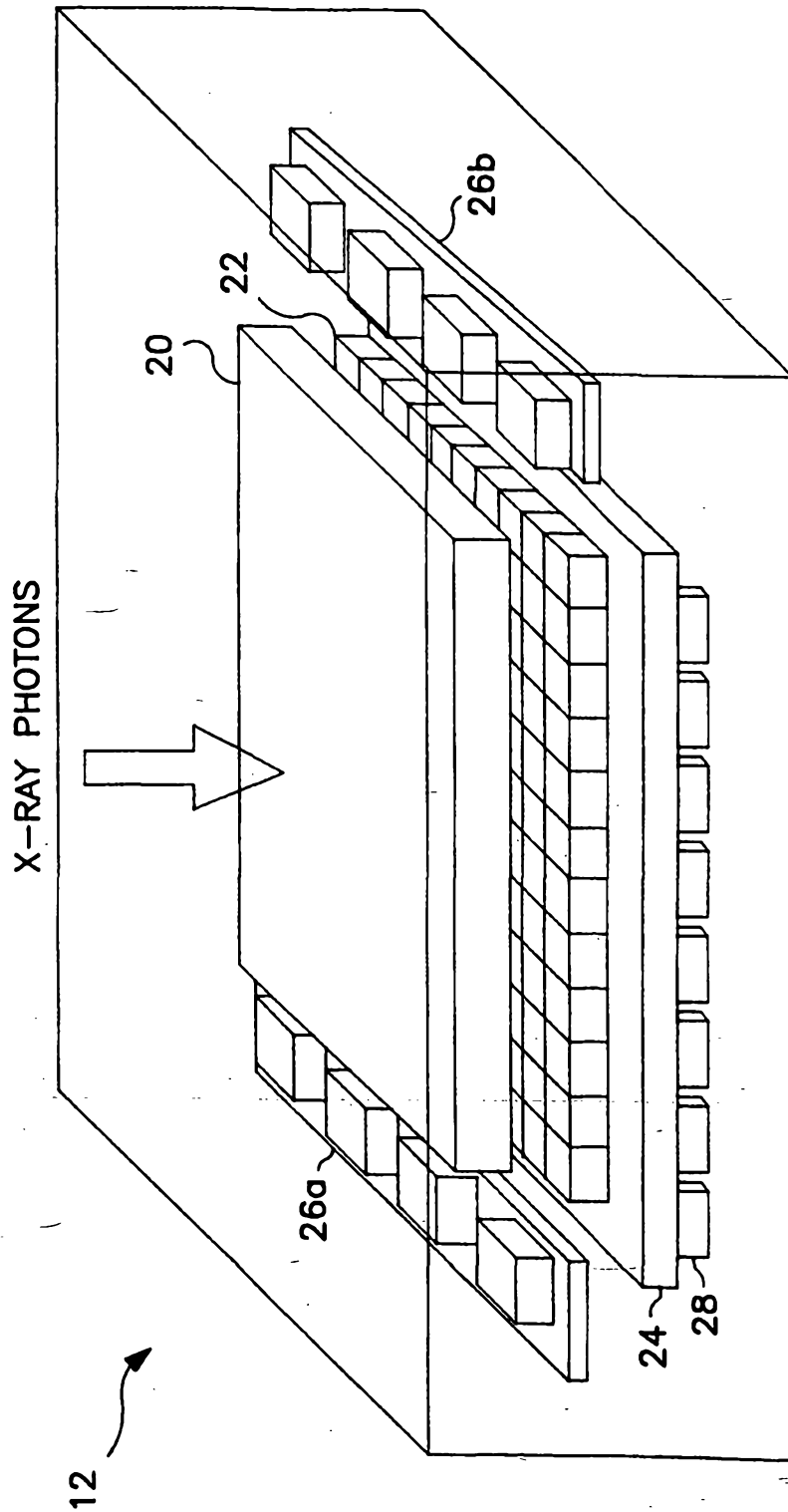

FIG. 2

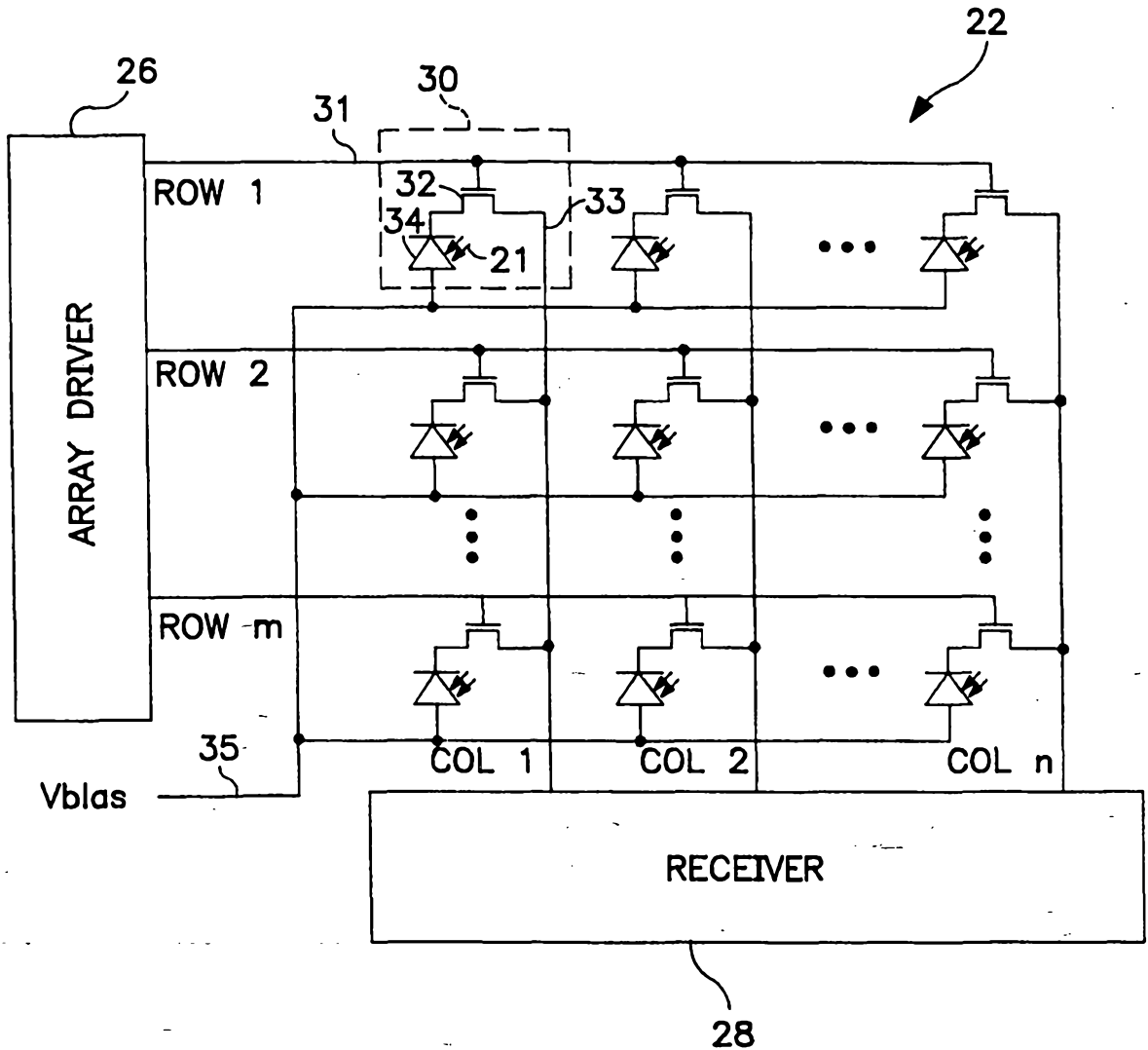

FIG. 3

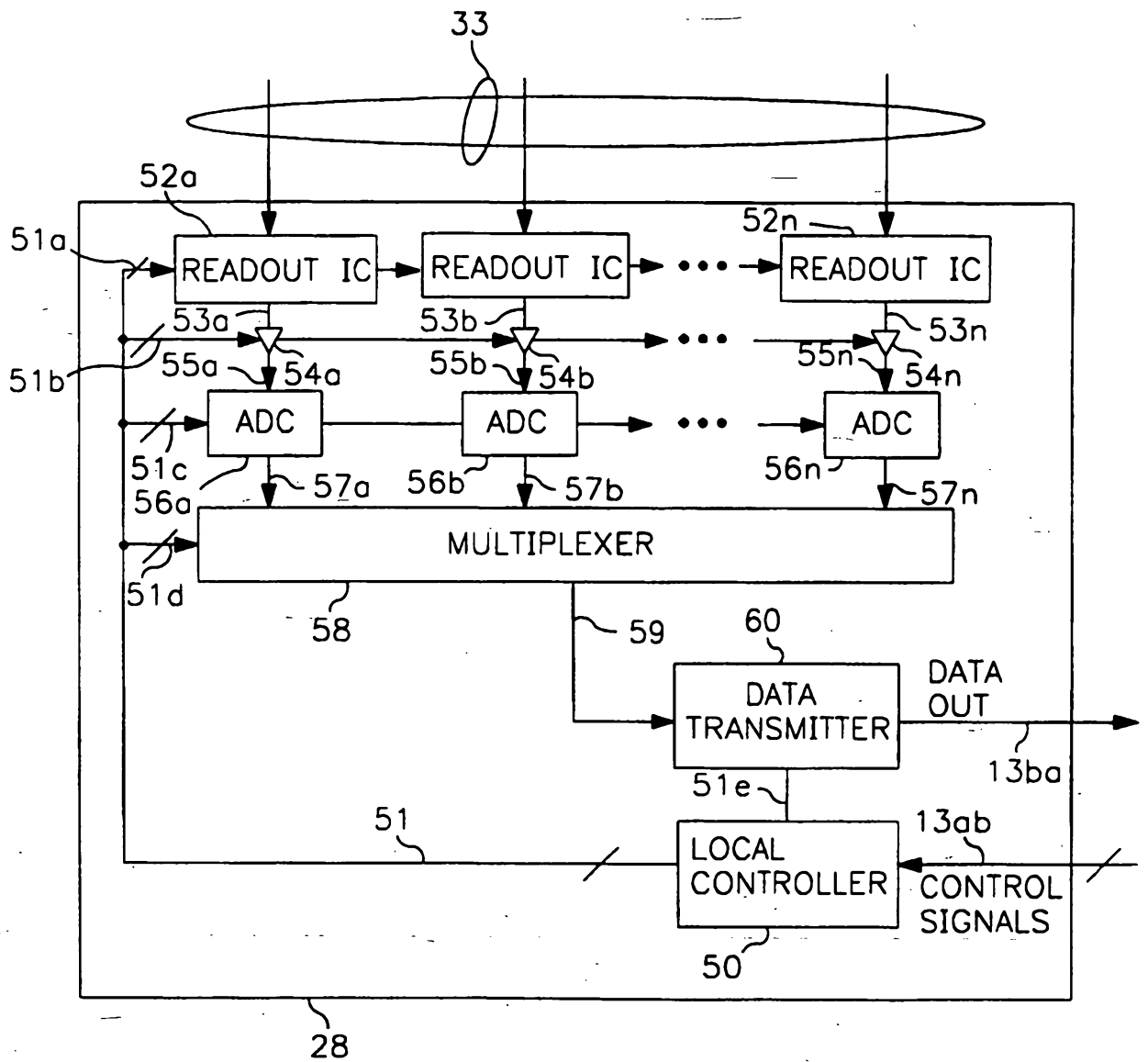

FIG. 5

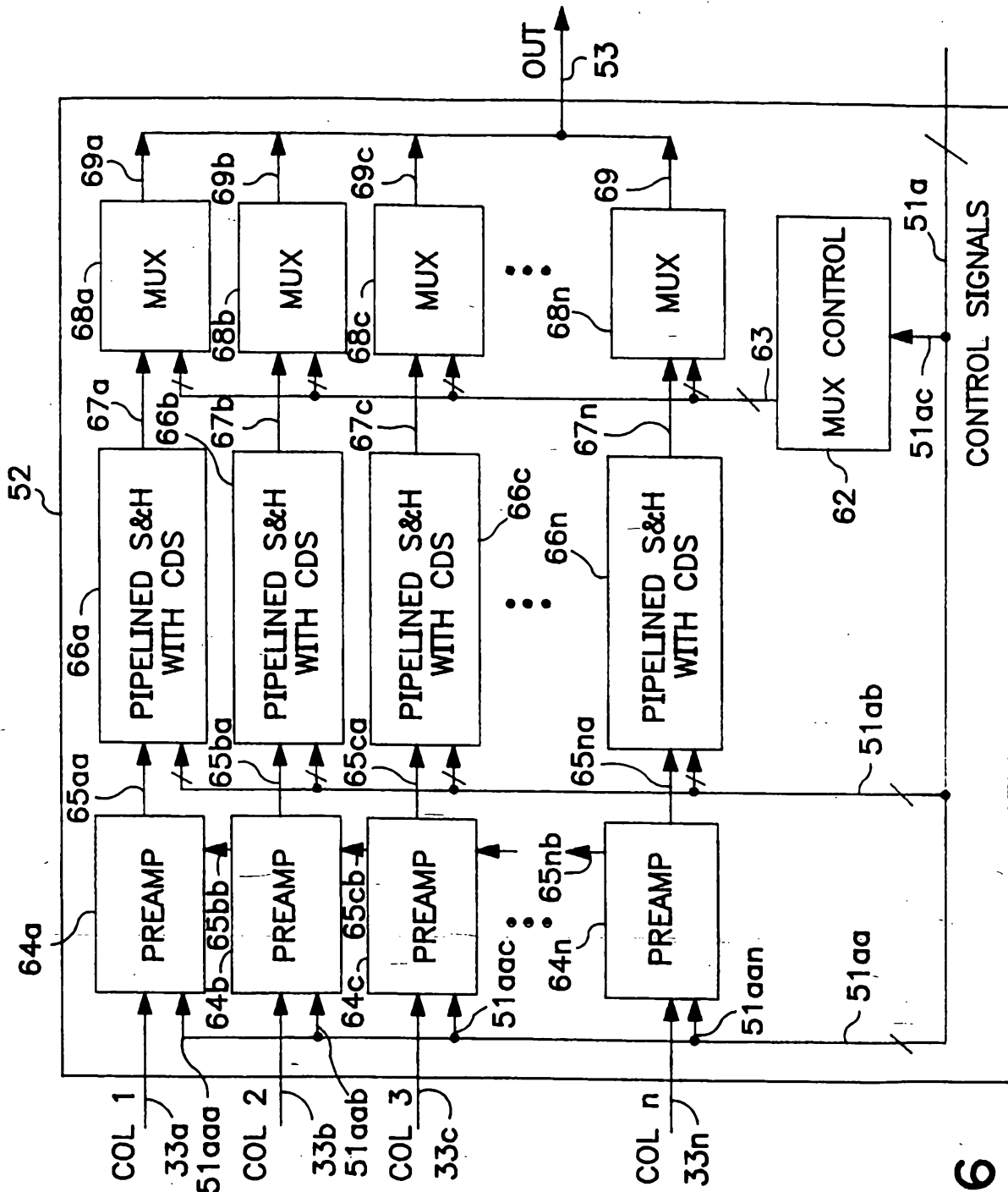

FIG. 6

7/14

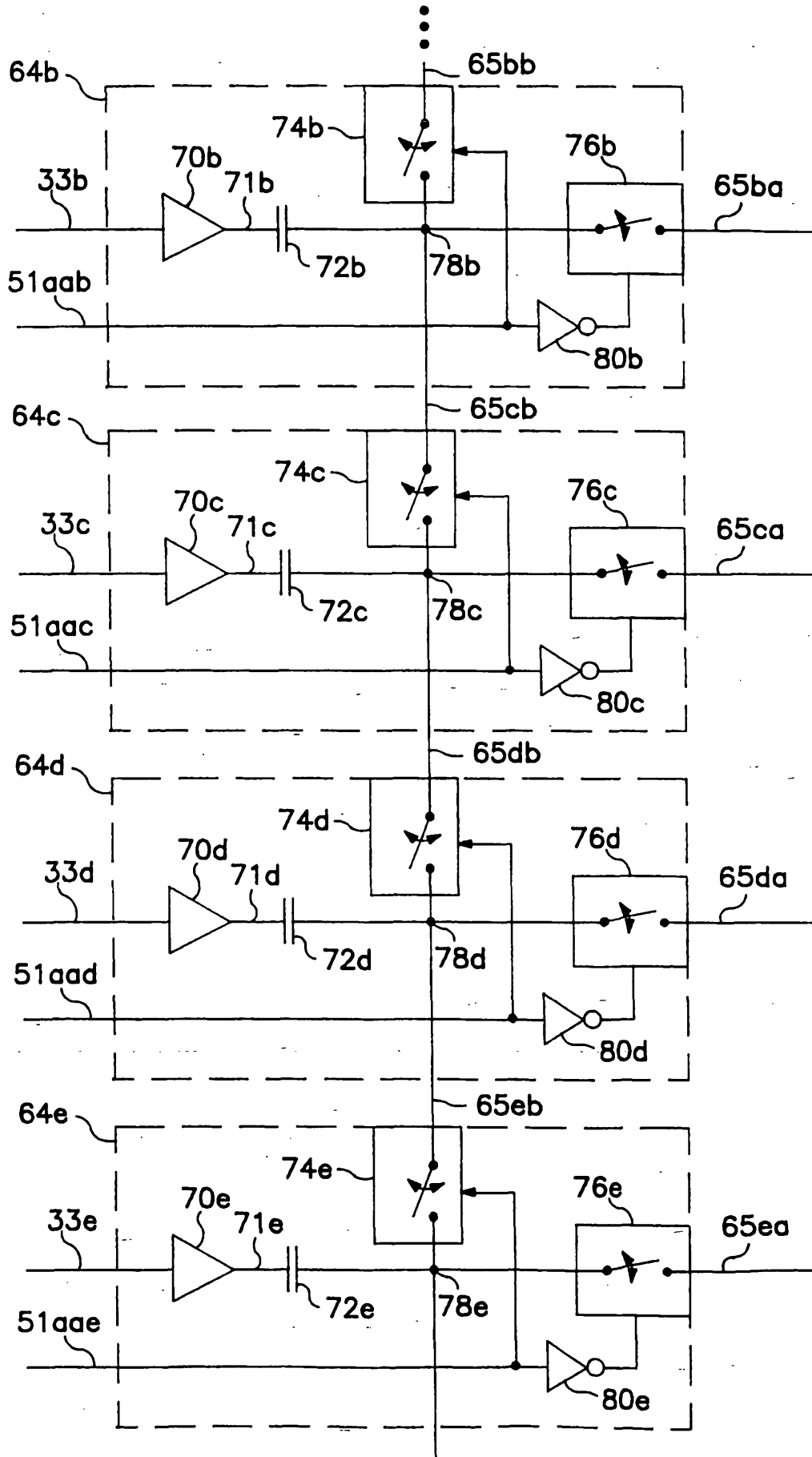

FIG. 7

SUBSTITUTE SHEET (RULE 26)

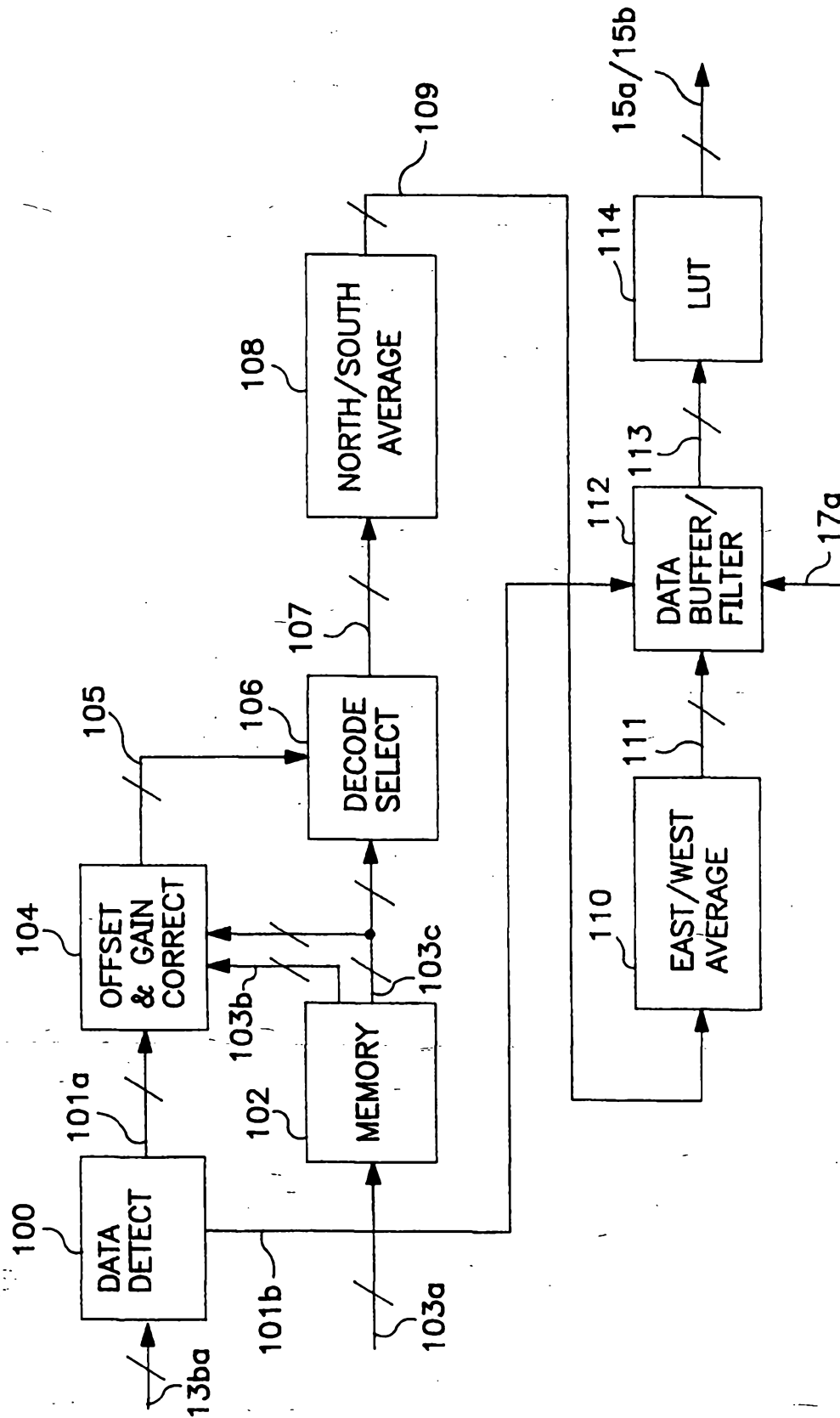
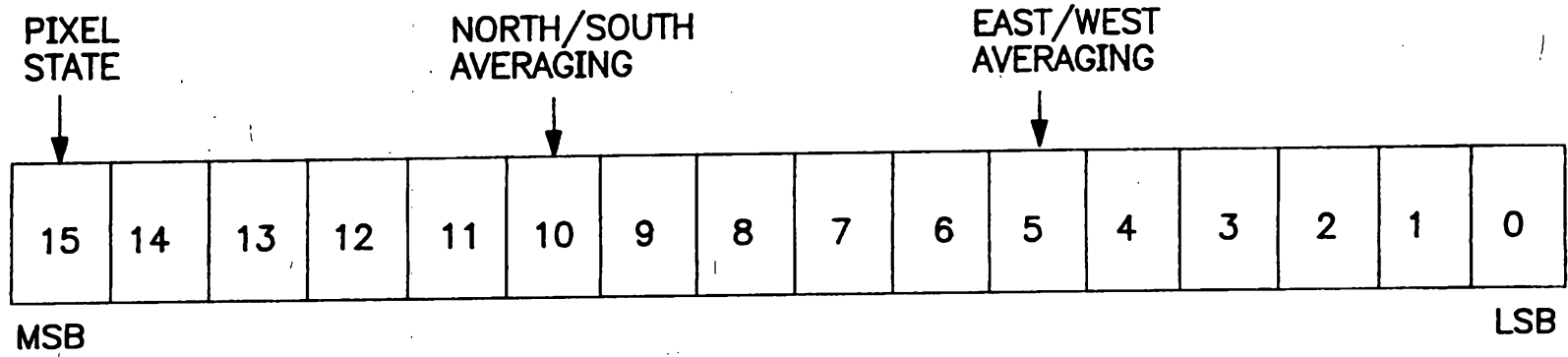

FIG. 8

14a



103c

FIG. 9

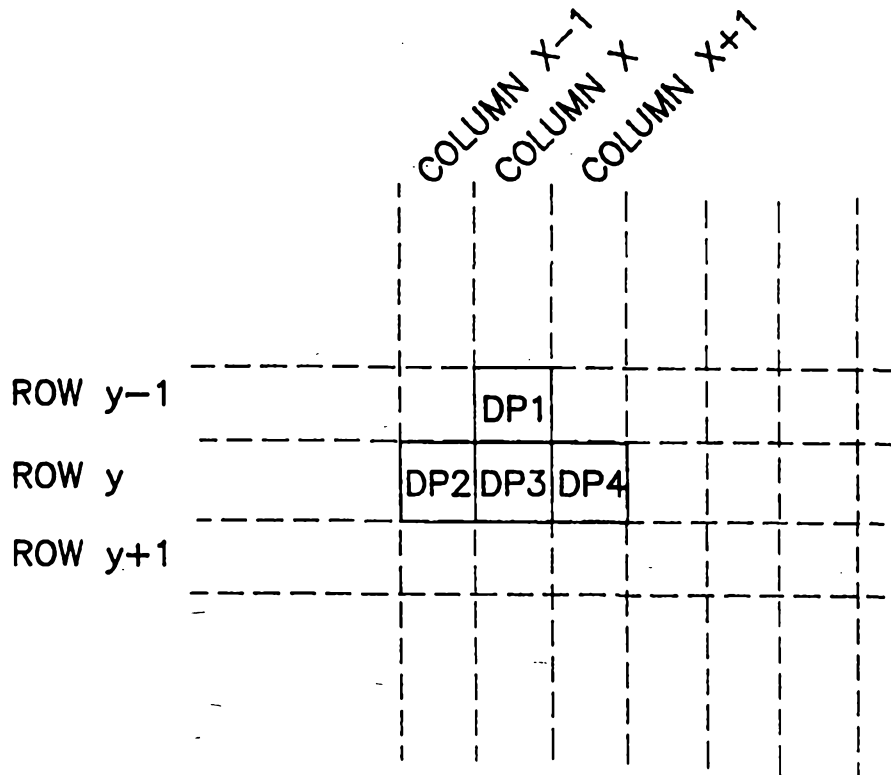
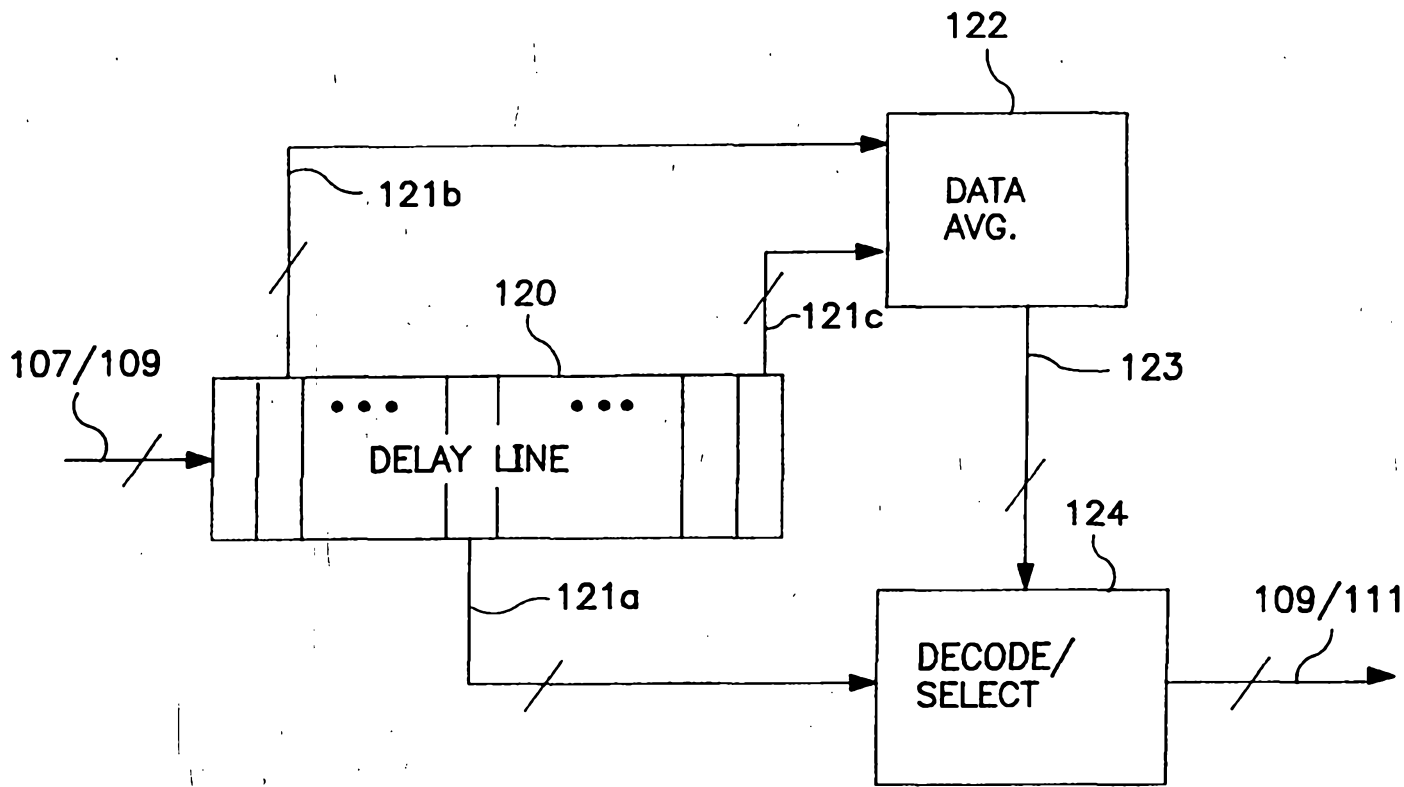

FIG. 10



108/110

FIG. 11

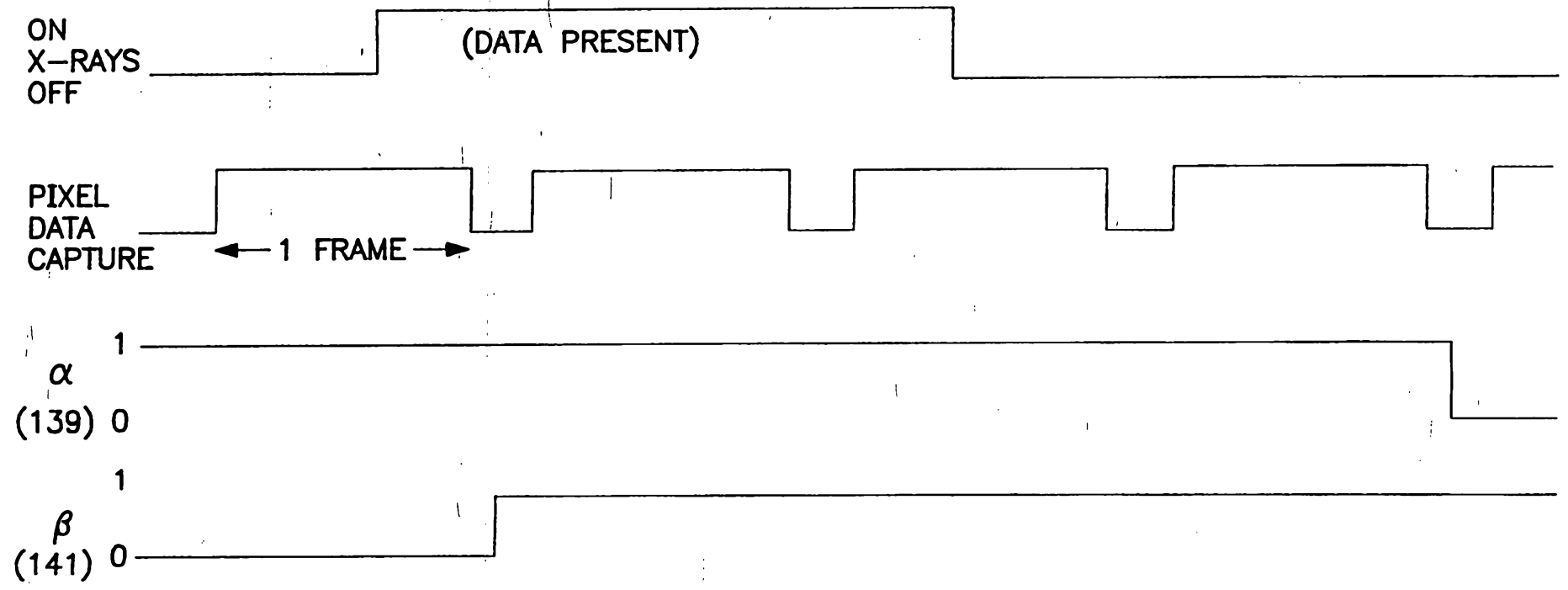

FIG. 13

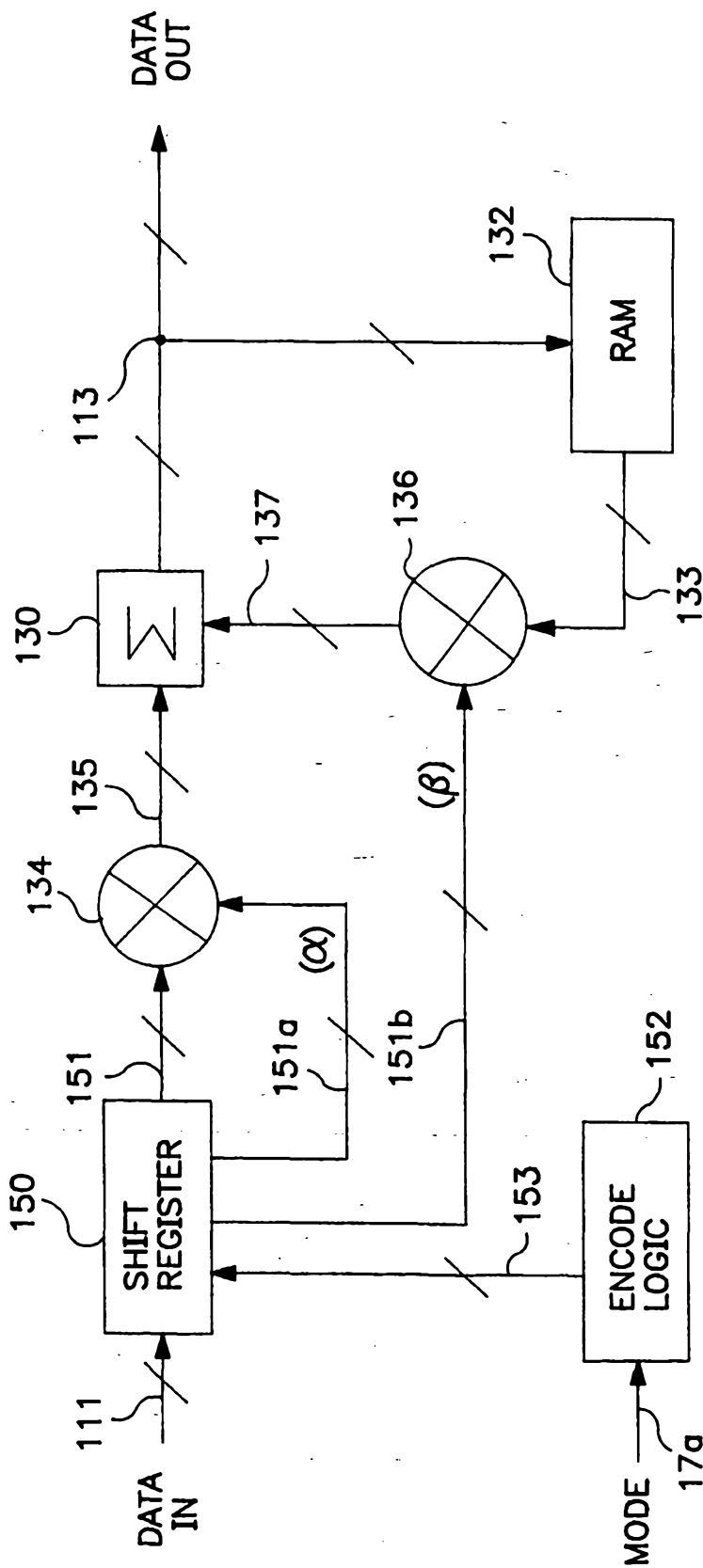

FIG. 14

112b