

(12) PATENT
(19) AUSTRALIAN PATENT OFFICE

(11) Application No. **AU 200197183 B2**
(10) Patent No. **755868**

(54) Title
Variable spacing strand coating system and modular guide roller therefor

(51)⁶ International Patent Classification(s)
B05C 001/04 B05D 001/26
B05C 005/02

(21) Application No: 200197183 (22) Application Date: 2001 . 12 . 11

(30) Priority Data

(31) Number	(32) Date	(33) Country
09/758702	2001 . 01 . 11	US

(43) Publication Date : 2002 . 07 . 18
(43) Publication Journal Date : 2002 . 07 . 18
(44) Accepted Journal Date : 2003 . 01 . 02

(71) Applicant(s)
Illinois Tool Works Inc.

(72) Inventor(s)
Edward W. Bolyard Jr.

(74) Agent/Attorney
PHILLIPS ORMONDE and FITZPATRICK, 367 Collins Street, MELBOURNE
VIC 3000

(56) Related Art
AU 200154130
US 4704311
EP 107301

ABSTRACT

A strand coating apparatus having an applicator head with a coating material dispenser coupled thereto, a strand guide roller coupled to the applicator head adjacent a coating material orifice of the dispenser, the strand guide roller having one or more strand guides each having a corresponding annular groove disposed about a hub, the one or more strand guides disposed and retained between a shoulder flange and removable locking collar of the hub, and in some embodiments one or more spacers are disposed between adjacent strand guides of the strand guide roller.

5



AUSTRALIA

Patents Act

**COMPLETE SPECIFICATION
(ORIGINAL)**

Class Int. Class

Application Number:
Lodged:

Complete Specification Lodged:
Accepted:
Published:

Priority

Related Art:

Name of Applicant:

Illinois Tool Works Inc.

Actual Inventor(s):

Edward W Bolyard Jr

Address for Service:

PHILLIPS ORMONDE & FITZPATRICK
Patent and Trade Mark Attorneys
367 Collins Street
Melbourne 3000 AUSTRALIA

Invention Title:

VARIABLE SPACING STRAND COATING SYSTEM AND MODULAR GUIDE ROLLER
THEREFOR

Our Ref : 656109
POF Code: 331914/1431

The following statement is a full description of this invention, including the best method of performing it known to applicant(s):

VARIABLE SPACING STRAND COATING SYSTEM
AND MODULAR GUIDE ROLLER THEREFOR

5 CROSS REFERENCE TO RELATED APPLICATION

The present application is related to co-pending U.S. Application No. 09/621,721
filed on 24 July 2000 entitled "Variable Spacing Strand Coating System And Method",
Attorney Docket No. 12635, assigned commonly with the present application and
10 incorporated by reference herein.

BACKGROUND OF THE INVENTION

15 The invention relates generally to strand coating systems, and more particularly to
variable spacing strand coating systems and guide rollers therefor.

An object of the present invention is to provide novel strand coating systems and
guide rollers therefor that overcome problems in and improve upon the prior art.

20 In particular, it would be desirable to provide novel strand coating systems and
guide rollers therefor that are economical and reliable.

25 SUMMARY OF THE INVENTION

According to one aspect of the present invention, there is provided a strand coating
applicator guide roller comprising a hub, a plurality of strand guides disposed in stacked
relation about the hub, each of the plurality of strand guides having a groove disposed on an
30 outer surface thereof, the grooves spaced apart along the axis of the hub.



According to another aspect of the invention there is provided a strand coating apparatus comprising a coating material dispenser with an orifice coupled to an applicator head, a strand guide roller coupled to the applicator head in spaced apart relation to the coating material dispenser, the strand guide roller having a hub and a plurality of separate strand guides disposed thereabout, the strand guides each having an annular groove disposed thereabout and located adjacent the coating material orifice.

According to yet a further aspect, the present invention provides a modular strand coating applicator guide roller system comprising a hub having an axial support opening with bearings, the hub having a radial shoulder flange, a collar removably disposed about the hub, the collar spaced axially from the shoulder flange, a plurality of separate annular strand guides removably disposed in stacked relation about the hub between the shoulder flange and the removable collar, each strand guide having a corresponding annular groove disposed on an outer surface thereof.

Advantageously, the invention is able to provide in some embodiments thereof novel strand coating systems and modular guide rollers therefor:

- having a plurality of spaced apart grooves for guiding corresponding strands;
- that may be assembled or configured from a limited set of components to provide different strand guide spacings;
- that may be configured from a limited set of components to accommodate different numbers of strands; and/or
- that are made less susceptible to misalignment by providing no more strand guide grooves than are required for an application.

The above and other features and advantages of the present invention will become more fully apparent upon careful consideration of the following detailed description of preferred embodiments of the invention with reference to the accompanying drawings, which may be disproportionate for ease of understanding, and in which like structures and steps are referenced generally by corresponding numerals and indicators.



BRIEF DESCRIPTION OF THE DRAWINGS

FIG. 1 is a strand coating system according to an exemplary embodiment of the invention.

FIG. 2 is a partial view of a strand coating applicator.

5 FIG. 3 is a partial view of an exemplary coating material dispenser in a first configuration.

FIG. 4 is another partial view of an exemplary coating material dispenser in a second configuration.

FIG. 5 is another view of an exemplary strand guide coupled to an exemplary strand coating applicator.

FIG. 6 is an exemplary strand guide roller.

FIG. 7 is a disassembled view of the strand guide roller of FIG. 6.

FIG. 8 is another exemplary strand guide roller.

FIG. 9 is a disassembled view of the strand guide roller of FIG. 8.

FIG. 10 is yet another exemplary strand guide roller.

FIG. 11 is a disassembled view of the strand guide roller of FIG. 10.

FIG. 12 is an end view of an exemplary annular strand guide.

DETAILED DESCRIPTION OF THE INVENTION

20 FIG. 1 illustrates a strand coating system comprising a coating material dispenser 10 for applying coating materials, for example a hot melt adhesive or an atomized substance, onto one or more strands, identified collectively by numeral 20, moving relative thereto.

25 The strands 20 may for example be elastic rubber or LYCRA materials used in the manufacture of diapers, incontinence pads and hospital garments and other articles. The

strands may also be wire or cable, for example a fiber optic cable, or some other elongated member onto which it is desirable to deposit a coating material.

In FIG. 3, the exemplary dispenser 10 includes a plurality of conduits 12, shown only partially and in phantom, terminating at corresponding coating material orifices arranged in a spaced apart series on a side 14 of the dispenser. The orifices of the exemplary dispenser each emit therefrom a corresponding coating material flow 16, which may be a substantially continuous or discrete vacillating filament or an atomized spray, toward a corresponding strand in alignment with the orifice.

In FIG. 3, some of the orifices 13 are illustrated schematically at the origin of the corresponding flows 16 spaced apart evenly in a single row on the dispenser. The orifices may be recessed or protrude from the side 14 of the dispenser. In other embodiments, the spacing between adjacent orifices is not necessarily the same. Alternatively, there may be more than one row or series of orifices arranged in alignment with the direction of the strand so that more than one orifice dispenses coating material onto each strand. In other embodiments, the orifices of adjacent rows may be offset.

Coating material dispensers suitable for use with the present invention are disclosed for example in U.S. Patent No. 5,902,540, entitled "Meltblowing Method and Apparatus" and in U.S. Patent No. 5,904,298, entitled "Improved Meltblowing Method and System", both of which are assigned commonly with the present application. These preferred exemplary devices are capable of producing filaments and atomized spray patterns that vacillate predominately non-parallel to the axis of the strands and provide precise control over the coating material dispensed therefrom.

In one embodiment, illustrated in FIG. 3, the coating material dispenser 10 dispenses substantially continuous coating material filaments 17 having a repeating, generally omega shaped pattern from the orifices thereof, only one of which is illustrated, as disclosed more fully in co-pending U.S. Application No. 09/143,883 entitled "Omega Spray Pattern And Method Therefor", which is assigned commonly with the present application and is incorporated herein by reference.

In other embodiments, the coating material dispenser may be a spiral spray nozzle having a single orifice that dispenses a corresponding spiral filament onto one or more strands, or alternatively some other coating material dispensing apparatus.

5 In FIG. 5, the exemplary coating material dispenser 10 is coupled to or mounted on an applicator head 40, which supplies coating material and in some embodiments heated air to the coating material dispenser, for example through a nozzle module 41, as is known generally by those having ordinary skill in the art.

10 In some applications, strands having coating material applied thereto are adhered to or deposited on a substrate moving relative to the coating material dispenser, usually in unison with the strands. The coating material dispenser however may move relative to the one or more strands and any substrate.

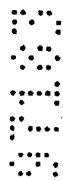

A strand guide having a guiding surface is preferably disposed adjacent the coating material dispenser, preferably on an upstream side thereof, to guide the strands past the coating material dispenser. The one or more strands are generally drawn over the guiding surface of the strand guide, which aligns the strands side by side in spaced apart relation relative to corresponding orifices of the coating material dispenser, for dispensing coating material dispensed therefrom onto the strands.



In the exemplary embodiment of FIG. 1, the strand guide is a rotatable strand guide roller 50 including a plurality of spaced apart grooves 52 disposed thereabout. The strands are each disposed in and guided along a corresponding groove. The spacing of at least some of the grooves generally corresponds with the spacing of the dispenser orifices. In the exemplary embodiment, the roller aligns and guides the strands adjacent a corresponding orifice of the coating material dispenser, as illustrated in FIG. 3. In alternative embodiments, coating material from a single orifice may be applied to multiple strands.

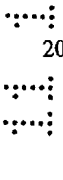

25 The strand guide is preferably coupled to the coating material dispenser, in fixed relation relative thereto. In the exemplary embodiment, the coating material dispenser and strand guide are both coupled to the applicator head, thereby eliminating or at least substantially reducing any misalignment therebetween, for example misalignment caused by

vibrating machinery, as frequently occurs in prior art systems having the strand guide coupled to machinery other than the coating material dispenser.

In FIGS. 1, 2 and 5, the exemplary roller guide 50 is rotatably coupled to a roller axle or shaft 54, preferably with roller bearings. In FIGS. 1 and 2, the exemplary roller guide 50 is retained on the roller shaft 54 by a collar 56 fastened thereto with a set screw or other fastening means.

The exemplary strand guide rollers of FIGS. 6, 8 and 10 are modular assemblies each configured differently from a limited set of components to accommodate different numbers of strands with different spacings therebetween.

In FIGS. 7, 9 and 11, which are disassembled views of FIGS. 6, 8 and 10 respectively, each strand guide roller is assembled about a hub 80 having an axial support opening 82 with bearings disposed thereabout, for example sealed bearings 83 located toward or at opposite ends of the axial support opening, only one of which is illustrated. A bushing may be a suitable equivalent for some applications. The hub 80 may thus be rotatably disposed about the roller shaft 54 as discussed above.

The exemplary hub 80 also includes a shoulder flange 84 toward or at one end thereof and a removable locking collar 86 retained about the hub by a set screw 87 or other retention member toward or at an opposite end of the hub. The exemplary shoulder 84 is an integral part of the hub, but in alternative embodiments it may be in the form of the removable locking collar or some other discrete member assembled with the hub.

In FIGS. 6-9, the strand guide rollers include a plurality of at least two strand guides 90 disposed about the hub and retained in side-by-side, or stacked relation, between the shoulder 84 and locking collar 86. In other embodiments, however, the strand guide rollers may include only a single strand guide.

In FIG. 12, the strand guide 90 is an annular member having at least one annular groove 92 disposed thereabout on an outer surface thereof.

The strand guides 90 also have a characteristic width that determines the spacing between adjacent grooves along the axis of the hub. For example, the strand guides

90 of FIGS. 6 and 7 are more narrow than the strand guides of FIGS. 8 and 9, thereby providing a closer strand spacing in FIG. 6.

In FIGS. 10 and 11, the strand guide roller includes annular spacers 94 between the plurality of strand guides 90, thereby further separating the spacing between grooves.

5 In an exemplary strand guide roller system suitable for guiding elastic and LYCRA strands used in the production of disposable diapers and other garments, the strand guides 90 are available in several widths, for example 3 mm, 4 mm and 5 mm widths and the spacer has a 1 mm width.

10 A variety of strand guide rollers having different numbers of grooves and different spacings therebetween may thus be configured with the limited number of components of the exemplary system. Other systems may include components having additional dimensions and/or other dimensions.

15 In FIGS. 2 and 5, the roller shaft 54 extends from a roller arm 58 adjustably coupled to the applicator head 40. The roller shaft is also preferably adjustably coupled to the roller arm, for example by threaded engagement with a threaded opening 59 of the roller arm 58. In the exemplary embodiment, the roller guide 50 and/or roller shaft 54 is adjustable in either direction along the axis of the shaft 54 to align the guide grooves of the roller 50 relative to the one or more orifices of the coating material dispenser.

20 In FIGS. 2 and 5, the roller arm 58 is pivotally coupled to a guide arm 62 by a pivot pin 64 extending from one or the other. The guide arm 62 is also preferably adjustably coupled to the applicator, for example by a pivot pin 66 extending from a bracket 63 mounted thereon.

25 In FIG. 5, the guide roller 50 may be adjustably positioned toward and away from a bottom side 42 the applicator head 40. The guide roller 50 may also be adjustably positioned in the upstream and downstream direction of the strands, closer or farther away from the dispenser.

In the exemplary embodiment of FIG. 5, the roller axle 54 is secured in the opening 59 of the roller arm 58 by a bolt 60 disposed through prongs 61 thereof, which are

clamped about the shaft 54 upon tightening the bolt. The guide arm 62 is similarly secured to the pivot pin 66, and the roller arm 58 is similarly secured to the guide arm 62. In other embodiments, the guide roller is adjustably coupled to the applicator head by other structure.

5 In some embodiments of the invention, the strand guide is adjustably mounted on a pivot member to change the orientation of the guiding surface of the strand guide to vary the spacing of the strands relative to the substrate. The coating material dispenser is preferably adjustable in unison with the strand guide, for example by adjusting the position or orientation of the applicator head, to facilitate application of the coating material onto the strands.

In the exemplary embodiments of FIGS. 3 and 4, spacing between the plurality of strands 20 as they are deposited onto the substrate 30 is varied by changing the orientation of the strand guide, not illustrated, and particularly the guiding surface thereof relative to a surface 32 of the substrate. The plane of the strands 20 corresponds generally to the orientation of the guiding surface of the strand guide relative to the substrate surface 32.

10
15 In the embodiment of FIG. 1, the grooved guiding surface of the strand guide 50 is parallel to the substrate surface 32, so that the plane of the strands 20 is also parallel to the substrate, as illustrated best in FIG. 3. The spacing between adjacent strands relative to the substrate surface 32 thus corresponds generally with the spacing between the grooves on the strand guide over which the strands are drawn. In FIG. 3, for example the spacing between the outermost strands is D1.

20
25 In FIG. 4, the strand guide has been pivoted to orient the grooved guiding surface thereof at an angle relative to the substrate so that the plane of the strands is at a corresponding angle relative to the substrate. The spacing between adjacent strands relative to the substrate surface 32 is thus reduced in some proportion to the angle between the substrate and the guiding surface of the strand guide over which the strands are drawn. In FIG. 4, the spacing between the outermost strands disposed over an angled strand guide is D2, which is less than the spacing D1 in FIG. 3.

FIGS. 1 and 2 illustrate the applicator head 40 pivotally mounted on a pivot or bolt shaft 70 having an axis substantially transverse to the side by side arrangement of the

plurality of orifices, which permits adjustment of the orientation of the coating material dispenser and strands, as illustrated in FIGS. 3 and 4. In FIGS. 3 and 4, the pivot axis of the coating material dispenser and strand guide is aligned substantially in a direction of the moving substrate, which moves into or out of the page of the drawing.

5 In FIGS. 1 and 2, the pivot shaft 70 extends through a mounting block 72 supported by a support member 74, in the exemplary form of a rod. In FIG. 2, the mounting block 72 includes one or more arcuate slots 76 disposed about the pivot shaft 70. A bolt 77 extends through the corresponding slot 76 and into a threaded bore of the applicator head 40.

10 Engagement of the bolt 77 with opposite end portions of the slot 76 limits pivoting or rotation of the applicator head 40 about the shaft 70, and engagement of a head portion of the bolt 77 with the mounting block 72 secures the orientation of the applicator head 40 relative thereto upon tightening the bolt 77.

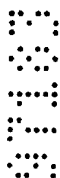

15

While the foregoing written description of the invention enables one of ordinary skill to make and use what is considered presently to be the best mode thereof, those of ordinary skill will understand and appreciate the existence of variations, combinations, and equivalents of the specific exemplary embodiments herein. The invention is therefore to be limited not by the exemplary embodiments herein, but by all embodiments within the scope and spirit of the appended claims.



Throughout the description and claims of this specification the word “comprise” and variations of that word such as “comprises” and “comprising” are not intended to exclude other additives, components, integers or steps.

THE CLAIMS DEFINING THE INVENTION ARE AS FOLLOWS:

1. A strand coating applicator guide roller comprising:
a hub;
5 a plurality of separate strand guides disposed about the hub, each strand guide having an annular groove disposed on an outer surface thereof, the grooves of the plurality of strand guides being spaced apart along the axis of the hub.
2. A strand coating applicator guide roller according to claim 1, including a spacer between
10 the plurality of strand guides.
3. A strand coating applicator guide roller according to claim 1, the hub having a shoulder flange thereon and a removable locking collar spaced apart axially from the shoulder flange, the strand guides disposed between the shoulder flange and the locking collar.
15
4. A strand coating applicator guide roller according to claim 3, including an axial support opening extending through the hub, bearings disposed in the hub about the axial support opening.
- 20 5. A strand coating apparatus comprising:
an applicator head;
a coating material dispenser coupled to the applicator head, the coating material dispenser having an orifice;
a strand guide roller coupled to the applicator head in spaced apart relation to the
25 coating material dispenser,
the strand guide roller having a hub and a plurality of strand guides disposed in stacked relation about the hub, each strand guide having at least one corresponding groove thereabout adjacent the coating material orifice.
- 30 6. An apparatus according to claim 5, the coating material dispenser having a plurality of coating material orifices, each orifice of the coating material dispenser aligned with a corresponding groove of the strand guide roller.
7. An apparatus according to claim 5, further including a support member, the applicator head pivotally coupled to the support member by a pivot member having an axis aligned non-parallel to a rotation axis of the hub.



8. An apparatus according to claim 5, including a roller shaft coupled to the applicator head, the hub rotatably disposed about the roller shaft.

5 9. An apparatus according to claim 8, including bearings rotatably coupling the hub to the roller shaft.

10. An apparatus according to claim 8, the roller shaft extending from a roller arm pivotally coupled to a guide arm pivotally coupled to the applicator head.

10 11. An apparatus according to claim 5, the hub having a shoulder flange thereon and a locking collar coupled thereto spaced apart axially from the shoulder flange, the strand guide disposed between the shoulder flange and the locking collar.

15 12. An apparatus according to claim 5, including a spacer between adjacent strand guides.

13. An apparatus according to claim 5, wherein the plurality of strand guides are substantially identical annular members removably disposed about the hub.

20 14. An apparatus according to claim 13, the hub having a shoulder flange thereon and a locking collar removable coupled thereto spaced apart axially from the shoulder flange, the plurality of strand guides disposed between the shoulder flange and the locking collar.

25 15. A modular strand coating applicator guide roller system comprising:
a hub having an axial support opening with bearings thereabout, the hub having a radial shoulder flange;
a locking collar removably disposed about the hub, the collar spaced axially from the shoulder flange;
a plurality of separate strand guides removably disposed in stacked relation about the hub between the shoulder flange and the removable collar,
30 each strand guide having a corresponding groove disposed on an outer surface thereof.

16. A system according to claim 15, including a plurality of annular spacers, one or more of the spacers disposed between adjacent strand guides.



17. A strand coating applicator guide roller system substantially as herein described with reference to the accompanying drawings.

18. A strand coating apparatus substantially as herein described with reference to the
5 accompanying drawings.

10 DATED: 29 October 2002

PHILLIPS ORMONDE & FITZPATRICK
Attorneys for:
ILLINOIS TOOL WORKS INC.

2
5
9
9
9



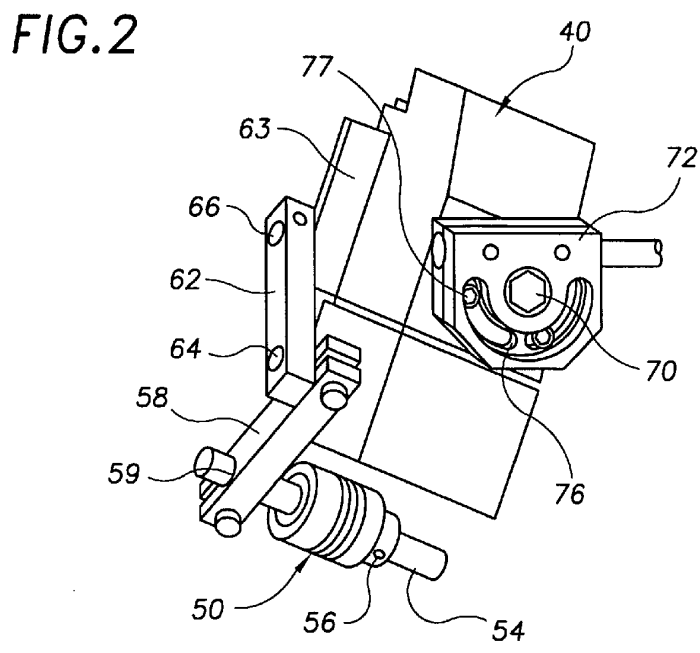
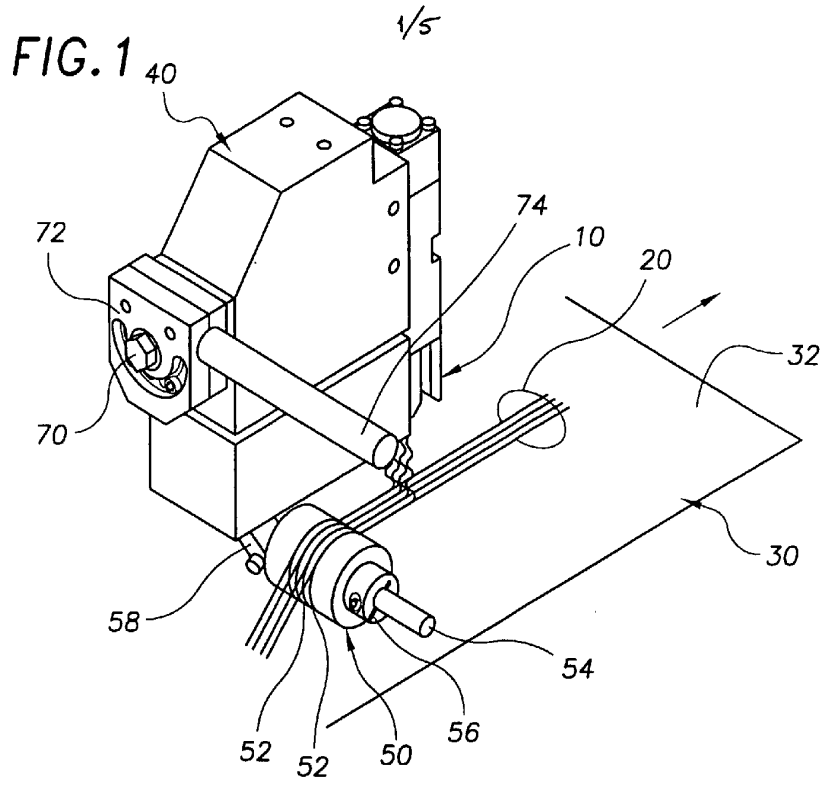

FIG. 3

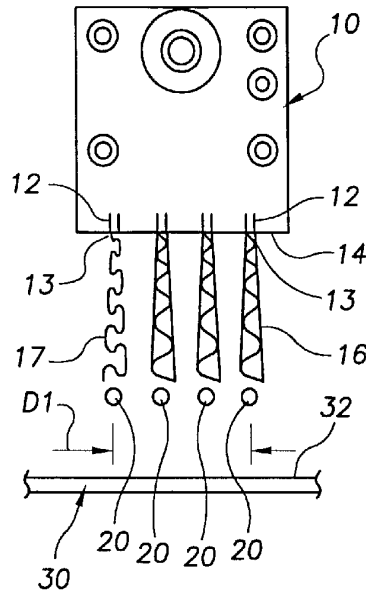

FIG. 4

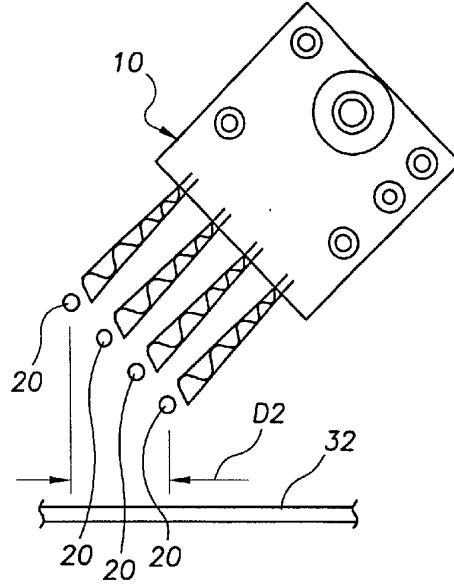
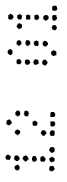
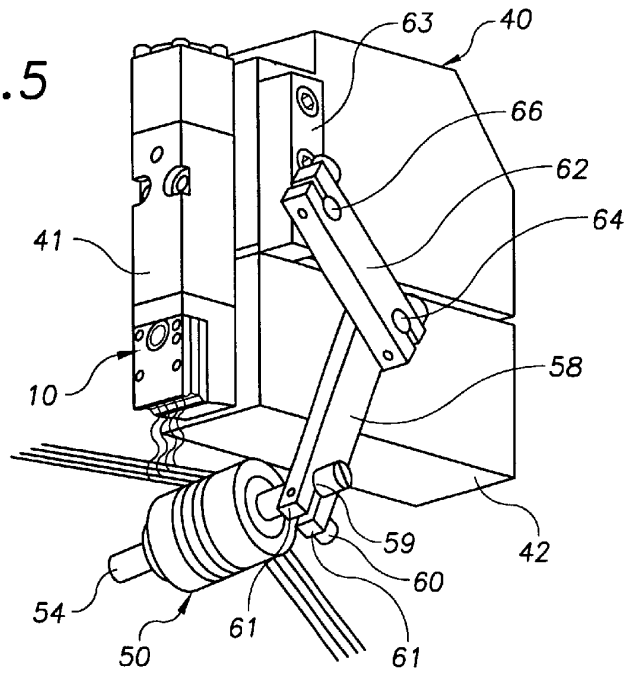

FIG. 5



11 12 03 97103

FIG. 6

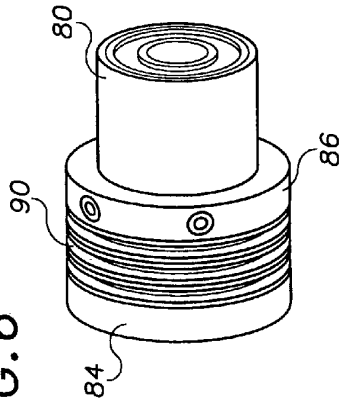

FIG. 8

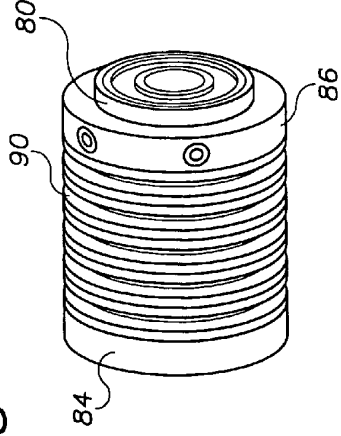
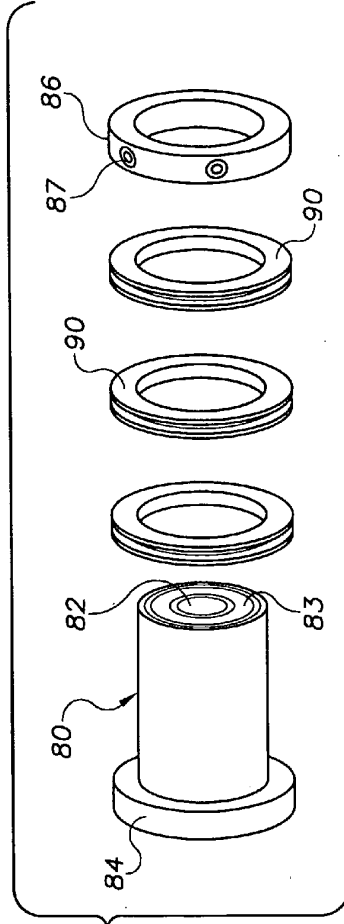

FIG. 7



11 12 01 9733

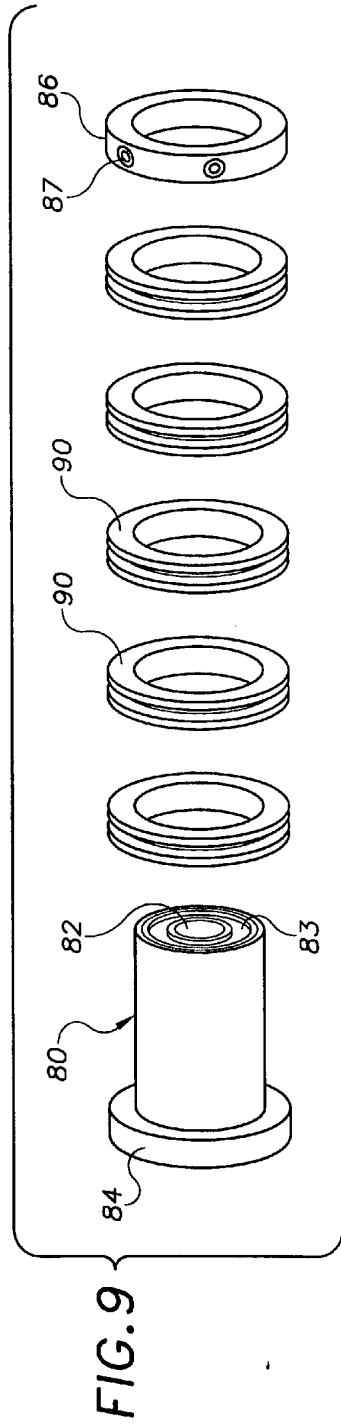
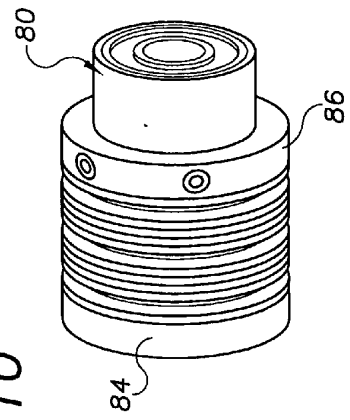

FIG. 10



11 12 01 9103

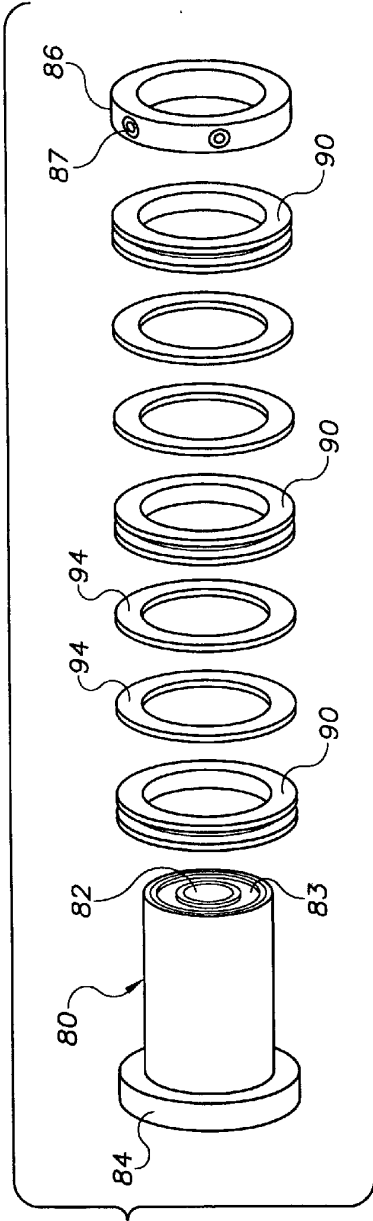

FIG. 11

5/5

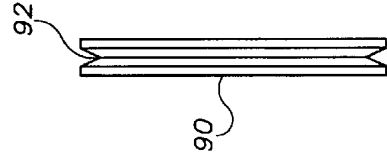

FIG. 12