



- (51) International Patent Classification:
G06F 13/42 (2006.01) G06F 13/40 (2006.01)
G06F 13/38 (2006.01)
- (21) International Application Number:
PCT/US2015/049431
- (22) International Filing Date:
10 September 2015 (10.09.2015)
- (25) Filing Language: English
- (26) Publication Language: English
- (30) Priority Data:
14/497,925 26 September 2014 (26.09.2014) US
- (63) Related by continuation (CON) or continuation-in-part (CIP) to earlier application:
US 14/497,925 (CON)
Filed on 26 September 2014 (26.09.2014)
- (71) Applicant: INTEL CORPORATION [US/US]; 2200 Mission College Boulevard, Santa Clara, California 95054 (US).
- (72) Inventors: NGE, Chee Lim; 6886 NE Vinings Way, APT 2432, Hillsboro, Oregon 97124 (US). SCHIFF, Todd; 8902 NW Benson St, Portland, Oregon 97229 (US). DIB-BAD, Vijayakumar; Intel Technology India Pvt Ltd, Var-

thur Hobli, Bangalore / KA 560103 (IN). HALLBERG, Alan; P.O. Box 1505, North Plains, Oregon 97133 (US).

(74) Agents: SCHEER, Bradley W. et al.; Schwegman Lundberg & Woessner, P.A., c/o CPA Global, P.O. Box 52050, Minneapolis, Minnesota 55402 (US).

(81) Designated States (unless otherwise indicated, for every kind of national protection available): AE, AG, AL, AM, AO, AT, AU, AZ, BA, BB, BG, BH, BN, BR, BW, BY, BZ, CA, CH, CL, CN, CO, CR, CU, CZ, DE, DK, DM, DO, DZ, EC, EE, EG, ES, FI, GB, GD, GE, GH, GM, GT, HN, HR, HU, ID, IL, IN, IR, IS, JP, KE, KG, KN, KP, KR, KZ, LA, LC, LK, LR, LS, LU, LY, MA, MD, ME, MG, MK, MN, MW, MX, MY, MZ, NA, NG, NI, NO, NZ, OM, PA, PE, PG, PH, PL, PT, QA, RO, RS, RU, RW, SA, SC, SD, SE, SG, SK, SL, SM, ST, SV, SY, TH, TJ, TM, TN, TR, TT, TZ, UA, UG, US, UZ, VC, VN, ZA, ZM, ZW.

(84) Designated States (unless otherwise indicated, for every kind of regional protection available): ARIPO (BW, GH, GM, KE, LR, LS, MW, MZ, NA, RW, SD, SL, ST, SZ, TZ, UG, ZM, ZW), Eurasian (AM, AZ, BY, KG, KZ, RU, TJ, TM), European (AL, AT, BE, BG, CH, CY, CZ, DE, DK, EE, ES, FI, FR, GB, GR, HR, HU, IE, IS, IT, LT, LU, LV, MC, MK, MT, NL, NO, PL, PT, RO, RS, SE, SI, SK, SM, TR), OAPI (BF, BJ, CF, CG, CI, CM, GA, GN, GQ, GW, KM, ML, MR, NE, SN, TD, TG).

[Continued on next page]

(54) Title: SERIAL BUS ELECTRICAL TERMINATION CONTROL

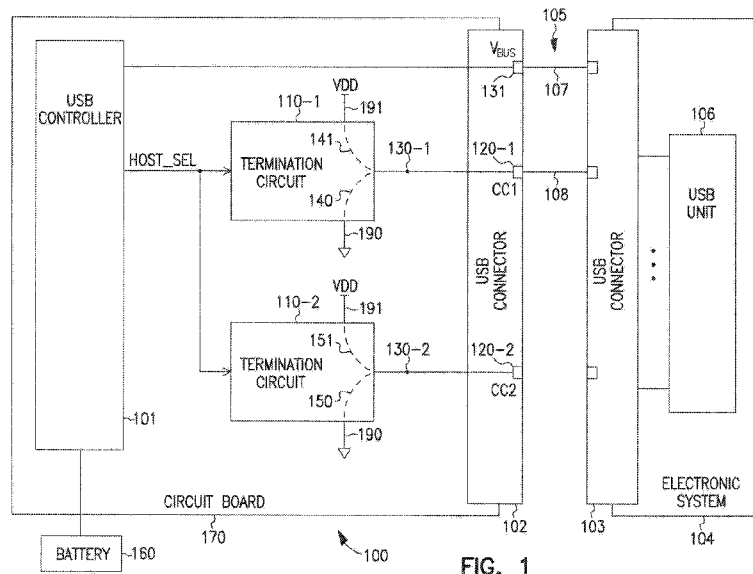

FIG. 1

(57) Abstract: Some embodiments include apparatuses and methods having a node to couple to a serial bus, and a controller to provide a control signal to one of a first circuit path and a second circuit path in order to change electrical termination of a signal at the node between a first electrical termination through the first circuit path during a first mode of the controller and a second electrical termination through the second circuit path during a second mode of the controller. The controller can be arranged to provide the control signal to the first and second circuit paths during the first and second modes without providing another control signal from the controller to the first and second circuit paths during the first and second modes.

WO 2016/048677 A1

Published:

— *with international search report (Art. 21(3))*

SERIAL BUS ELECTRICAL TERMINATION CONTROL

5

CLAIM OF PRIORITY

[0001] This patent application claims the benefit of priority to U.S. Application Serial No. 14/497,925, filed September 26, 2014, which is hereby incorporated by reference herein in its entirety.

10

TECHNICAL FIELD

[0002] Embodiments described herein pertain to electronic data communication. Some embodiments relate to Universal Serial Bus (USB) communication.

15

BACKGROUND

[0003] A serial bus connection (e.g., USB cable) is one of different types of connections that allow communication between electrical systems or devices. Some systems (e.g., personal computers) may include a serial bus controller that can be configured to operate in different roles at different times. For example, some USB controllers may be configured to operate as a dual-role USB controller, such as a USB host role and a USB device role. In accordance with USB specification, a signal at a certain pin of a USB connector is required to have a specific electrical termination, depending on which role the USB controller coupled to the USB connector operates. If the electrical termination required by USB specification is poorly implemented in a device or system, control logic for the USB controller of the device or system, circuit board layout, or both may be complicated.

30

BRIEF DESCRIPTION OF THE DRAWINGS

[0004] FIG. 1 shows an apparatus including a USB controller and termination circuits, according to some embodiments described herein.

[0005] FIG. 2 shows a schematic diagram of a termination circuit to provide electrical termination to a signal at a node, according to some embodiments described herein.

[0006] FIG. 3 shows a schematic diagram of a termination circuit that
5 can be a variation of the termination circuit of FIG. 2, according to some embodiments described herein.

[0007] FIG. 4 shows a schematic diagram of a termination circuit including details of a switch, according to some embodiments described herein.

[0008] FIG. 5 shows an apparatus in the form of a system, according to
10 some embodiments described herein.

[0009] FIG. 6 is flowchart showing a method of operating a USB device or system, according to some embodiments described herein.

DETAILED DESCRIPTION

15 [0010] FIG. 1 shows an apparatus 100 including a USB controller 101 and termination circuits 110-1 and 110-2, according to some embodiments described herein. Apparatus 100 can include or be included in an electronic communication device or system, such as a computer (e.g., notebook, laptop, or table), a cellular phone, or other electronic communication devices or systems.

20 USB controller 102 and termination circuits 110-1 and 110-2 can be arranged (e.g., configured) to operate in accordance with USB specification.

[0011] USB specification described herein refers to all USB specifications published by USB Implementers Forum Inc. in San Francisco, California, including USB 3.1 Specification Revision 1.0, published on July 16,
25 2013; USB Power Delivery Specification Revision 2.0, published on August 11, 2014; and USB Type-C Cable and Connector Specification Revision 1.0, published on August 11, 2014.

[0012] As shown in FIG. 1, apparatus 100 can include a USB connector 102 to allow it to couple to and communicate (e.g., exchange electrical signals)
30 with another electronic device or system in accordance with USB specification. For example, USB connector 102 can be coupled to a USB connector 103 of electronic system 104 through a USB connection (e.g., USB cable) 105. Electronic system 104 can include a USB unit 106 (e.g., a USB host, USB

device, or USB dual-role host and device) that can operate in accordance with USB specification. Although not shown in FIG. 1, USB unit 106 may include a USB controller and termination circuits that are similar to, or identical to, USB controller 101 and termination circuits 110-1 and 110-2 of apparatus 100.

5 [0013] Each of USB connectors 102 and 103 can include a USB Type-C connector, a USB Type-C adapter, or another type of connector or adapter compatible with a USB Type-C connector.

[0014] USB connection 105 can include a combination of USB Type-C connectors (not shown for simplicity) and wires (e.g., copper wires) to allow it to
10 couple to (e.g., mate with) USB connectors 102 and 103. For simplicity, only two wires 107 and 108 of USB connection 105 are shown in FIG. 1. USB connection 105 includes other wires (not shown) for conducting signals (e.g., D+, D-, ground, etc.) in accordance with USB specification. In the example of FIG. 1, wire 107 can be used to carry power (e.g., voltage V_{BUS}) between USB
15 connectors 102 and 103. Wire 108 can be used to carry Configuration Channel (CC) information (e.g., CC signal) in accordance with USB Type-C Cable and Connector Specification.

[0015] As shown in FIG. 1, USB connector 102 can include pins 120-1, 120-2, and 131. USB connector 102 also includes other pins (not shown) for
20 conducting signals (e.g., D+, D-, ground, etc.) in accordance with USB specification. In FIG. 1, pin 131 can correspond to V_{BUS} pin of a USB Type-C connector and can be coupled to wire 107 of USB connection 105 to provide power to or receive power from USB unit 106. Pins 120-1 and 120-2 can correspond to CC1 and CC2 pins, respectively, of a USB Type-C connector
25 (e.g., USB Type-C receptacle). Each of pins 120-1 and 120-2 can be referred to as a Configuration Channel pin (CC pin).

[0016] Connector 102 can be arranged such that either pin 120-1 or pin 120-2, but not both, can be coupled to the Configuration Channel (e.g., wire 108) of a USB connection (e.g., USB connection 105) as specified by USB Type-C
30 Cable and Connector Specification. FIG. 1 shows an example where pin 120-1 is coupled to the Configuration Channel (e.g., wire 108) of USB connection 105 and pin 120-2 is not coupled to the Configuration Channel of USB connection 105. However, in another example, pin 120-2 can be coupled to the

Configuration Channel of USB connection 105 and pin 120-1 is not coupled to the Configuration Channel of USB connection 105.

[0017] Apparatus 100 can include nodes 130-1 and 130-2 coupled to pins 120-1 and 120-2, respectively, of USB connector 102. The signals at nodes 130-1 and 130-2 are the same as the signals at pins 120-1 and 120-2, respectively. Depending on which mode (e.g., USB host mode or USB device mode) that USB controller 101 operates (as described in more detail below), the signals at nodes 130-1 and 130-2 can be terminated to a supply node 191 (e.g., terminate to voltage VDD in USB host mode) or to a supply node 190 (e.g., terminate to ground in USB device mode).

[0018] Termination circuit 110-1 can be arranged to provide different electrical terminations for the signal at node 130-1. For example, termination circuit 110-1 can terminate the signal at node 130-1 to supply node 191 through a circuit path 141 or to supply node 190 through a circuit path 140. Circuit path 141 can include a resistor (e.g., a pull-up resistor) between node 130-1 (e.g., CC1 pin) and supply node 191. Circuit path 140 can include a resistor (e.g., a pull-down resistor) between node 130-1 and supply node 190.

[0019] Termination circuit 110-2 can be arranged to provide different electrical terminations for the signal at node 130-2. For example, termination circuit 110-2 can terminate the signal at node 130-2 to supply node 191 through a circuit path 151 or to supply node 190 through a circuit path 150. Circuit path 151 can include a resistor (e.g., a pull-up resistor) between node 130-2 (e.g., CC2 pin) and supply node 191. Circuit path 150 can include a resistor (e.g., a pull-down resistor) between node 130-2 and supply node 190.

[0020] Termination circuits 110-1 and 110-2 can be controlled by the same control signal HOST_SEL and can include similar, or identical, elements (e.g., transistors, diodes, and resistors, which are not shown in FIG. 1).

[0021] USB controller 101 can generate control signal HOST_SEL and use it to control termination circuits 110-1 and 110-2 in order to control (e.g., change) electrical terminations of the signals at nodes 130-1 and 130-2. USB controller 101 (that can be included in a USB unit of apparatus 100) can be arranged to operate in different modes (e.g., different USB roles). For example, USB controller 101 can operate as a USB host (e.g., as a USB Downstream

Facing Port (DFP)) at one time and as a USB device (e.g., as a USB Upstream Facing Port (UFP)) at another time. Thus, USB controller 101 can be arranged to operate as a USB dual-role (USB host and device), such as USB dual-role port (DRP). USB controller 101 can use control signal HOST_SEL to cause
5 termination circuits 110-1 and 110-2 to change electrical terminations of the signals at nodes 130-1 and 130-2, depending on which mode USB controller 101 operates.

[0022] For example, USB controller 101 can use control signal HOST_SEL to cause termination circuits 110-1 and 110-2 to terminate the
10 signals at node 130-1 and 130-2 to supply node 191 if USB controller 101 operates as a USB host (e.g., USB host port). USB controller 101 can use control signal HOST_SEL to cause termination circuits 110-1 and 110-2 to terminate the signals at node 130-1 and 130-2 to supply node 190 if USB controller 101 operates as a USB device (e.g., USB device port).

15 [0023] As shown in FIG. 1, apparatus 100 can include a battery 160 to provide supply power to USB controller 101 and other parts of apparatus 100. USB controller 101 can be in a powered condition or in an unpowered condition. The powered and unpowered conditions in USB controller 101 can include powered and unpowered conditions in a USB unit (a USB host (e.g., DFP), a
20 USB device (e.g., UFP), or USB dual-role port (DRP)) in accordance with USB specification.

[0024] In FIG. 1, for example, the powered condition of USB controller 101 can occur when the level of battery 160 is at a sufficient (e.g., normal) level (e.g., 3.3V or 5.5V) that allows USB controller 101 to operate (e.g., as USB host
25 or device) in accordance with USB specification. In the powered condition, USB controller 101 can control electrical terminations at nodes 130-1 and 130-2 in order to allow it to operate as a USB host or a USB device, as described above.

[0025] The unpowered condition of USB controller 101 can occur when
30 battery 160 is dead (or deemed to be dead) or when battery 160 is in a dead battery state. The dead battery state may occur when the power level of battery 160 is zero or is less than a selected value (e.g., predetermined value). The dead battery state may also occur when the value of voltage VDD at supply node 191

is zero or less than a selected value (e.g., predetermined value). For example, if voltage VDD has a normal voltage of 3.3V, the dead battery state may occur when the value of voltage VDD is less than 2V. USB controller 101 may enter (e.g., or may be in) a dead battery state when it is in an unpowered condition.

5 [0026] USB controller 101 (or apparatus 100) can be arranged to receive power from another device or system (e.g., electronic system 104) when USB controller 101 is in an unpowered condition. Termination circuits 110-1 and 110-2 can to allow USB unit 106 to detect connection (e.g., the presence) of USB controller 101 (or apparatus 100) when USB controller 101 (or apparatus
10 100) is in an unpowered condition. This allows USB unit 106 to provide power to USB controller 101. USB controller 101 may use the power provided by USB unit 106 to charge battery 160. USB controller 101 may switch from the unpowered condition (e.g., a dead battery state) to the powered condition when battery 160 is charged to a sufficient level.

15 [0027] Termination circuits 110-1 and 110-2 can be arranged such that USB unit 106 can treat USB controller 101 as a USB device (e.g., UFP) when USB unit 106 detects connection of USB controller 101 and USB controller 101 is in an unpowered condition. This allows USB unit 106 to operate as a USB host (e.g., DFP) and provide power to USB controller 101. USB unit 106 can
20 detect connection of USB controller 101 and treat it as a USB device if the voltage on the Configuration Channel (e.g., on wire 108) of USB connection 105 is less than an unterminated voltage of USB unit 106 voltage (e.g., less than voltage VDD as specified by USB specification). Termination circuits 110-1 and 110-2 are arranged such that the voltage at each of nodes 130-1 and 130-2
25 can be less than the unterminated voltage of USB unit 106 when USB unit 106 is coupled to connector 102 and USB controller 101 is in an unpowered condition. For example, termination circuits 110-1 and 110-2 can terminate the signals at nodes 130-1 and 130-2 to supply node 190 to cause the voltage on the Configuration Channel (e.g., pin 120-1 or 120-2) to be less than the
30 unterminated voltage of USB unit 106 when USB unit 106 is coupled to connector 102 and USB controller 101 is in an unpowered condition.

[0028] As shown in FIG. 1, apparatus 100 may include a circuit board 170. USB controller 101 can include or be included in an integrated circuit (IC)

chip (e.g., a semiconductor chip or IC package) that can be attached (e.g., mounted on) to circuit board 170.

[0029] FIG. 1 shows an example where termination circuits 110-1 and 110-2 are located on circuit board 170 and outside USB controller 101. In an alternative arrangement, at least a portion of each of termination circuits 110-1 and 110-2 can be included in USB controller 101. For example, a portion of termination circuit 110-1, a portion of termination circuit 110-2, or both can be included in the same chip with USB controller 101. In another example, the entire termination circuit 110-1, 110-2, or both, can be included in the same chip with USB controller 101.

[0030] The above description uses USB communication technique as an example. The embodiments described herein may also apply to other communication techniques besides USB communication technique. For example, the embodiments described herein may apply to electronic systems (or devices) that may communicate with each other in accordance with another type of serial bus specification different from USB specification.

[0031] Each of termination circuit 110-1 and 110-2 described above may include embodiments of the termination circuits described below with reference to FIG. 2 through FIG. 4.

[0032] FIG. 2 shows a schematic diagram of a termination circuit 210 to provide electrical termination to a signal at a node 230, according to some embodiments described herein. Termination circuit 210 can be used as (or can correspond to) termination circuit 110-1 or 110-2 of FIG. 1. Node 230 of FIG. 2 can correspond to node 130-1 or 130-2 of FIG. 1. Thus, node 230 of FIG. 2 can be arranged to couple to a Configuration Channel of a USB connection (e.g., USB connection 105 of FIG. 1). For example, node 230 of FIG. 2 can be coupled to Configuration Channel of a USB connection through a CC1 pin or a CC2 pin of a USB Type-C connector, such as USB connector 102 of FIG. 1.

[0033] Termination circuit 210 in FIG. 2 can receive control signal HOST_SEL generated by a USB controller 201, which can correspond to USB controller 101 of FIG. 1. Termination circuit 210 can respond to control signal HOST_SEL to provide different electrical terminations for the signal at node 230 to allow USB controller 201 to operate in different modes (e.g., USB host

mode or USB device mode). In FIG. 2, termination circuit 210 can include a supply node 291 to receive a voltage VDD (e.g., a positive supply rail voltage) and a supply node 290 that can be coupled to ground. Supply nodes 290 and 291 can be coupled to a battery (e.g., battery 160 of FIG. 1).

5 [0034] Termination circuit 210 can terminate the signal at node 230 to supply node 291 through a circuit path 241 if USB controller 201 operates in USB host mode (e.g., operates as a USB host). Termination circuit 210 can terminate the signal at node 230 to supply node 290 through a circuit path 240 if
10 USB controller 201 operates in USB device mode (e.g., operates as a USB device).

[0035] As shown in FIG. 2, termination circuit 210 can include a switch 225, a diode D1, and resistors R1, R2, and R3. Resistor R1 can be included in circuit path 241. Diode D1 and resistor R3 can be included in circuit path 240. As shown in FIG. 2, diode D1 and resistor R3 can be coupled in series directly
15 between node 230 and supply node 290.

[0036] In a powered condition of USB controller 201, the signal at node 230 can be terminated to supply node 291 to allow USB controller 201 to operate in USB host mode. In this USB host mode, USB controller 201 can drive control signal HOST_SEL to a level (e.g., logic one level) in order to turn
20 on switch 225. This can couple node 226 to supply node 291 through switch 225, such that a voltage V_{HOST} at node 226 can be voltage VDD (e.g., 3.3V). Diode D1 is reversed biased (because of the connection of resistor R2). Thus, node 230 is not coupled to supply node 290 through R3. The signal at node 230 is terminated (e.g., pulled up) to voltage V_{HOST} (or voltage VDD at node 291)
25 through resistor R1. This allows USB controller 201 to operate in USB host mode.

[0037] In a powered condition of USB controller 201, the signal at node 230 can be terminated to supply node 290 to allow USB controller 201 to operate in USB device mode. In this USB device mode, USB controller 201 can
30 drive control signal HOST_SEL to a level (e.g., logic zero level) in order to turn off switch 225. When switch 225 is turned off, node 226 is decoupled from supply node 291 and has high impedance to ground. When a USB unit (e.g., USB unit 106 in FIG. 1) is coupled to node 230 through Configuration Channel

of a USB connection (e.g., through wire 108 in FIG. 1), the voltage (e.g., supply voltage such as VDD) from the USB unit applied to node 230 can cause diode D1 to be forward biased. The signal at node 230 can be terminated (e.g., pulled down) to ground at node 290 through resistor R3. This allows USB controller 201 to operate in USB device mode.

[0038] In an unpowered condition of USB controller 201, termination circuit 210 can allow another USB unit (e.g., USB unit 106 of FIG. 1) to detect connection (e.g., the presence) of USB controller 201 (or apparatus 100) and provide power to USB controller 201. In the unpowered condition, control signal HOST_SEL can be at zero volts. Thus, switch 225 is turned off. Node 226 has high impedance to ground. The voltage VDD at node 291 may have a value of zero volts (e.g., USB controller 201 is in a dead battery state). When a USB unit (e.g., USB unit 106 in FIG. 1) is coupled to node 230 through a Configuration Channel of a USB connection (e.g., through wire 108 in FIG. 1), the voltage (e.g., supply voltage such as VDD) from the USB unit applied to node 230 can cause diode D1 to be forward biased. The signal at node 230 can be terminated (e.g., pulled down) to ground at node 290 through resistor R3. This allows the USB unit to detect connection of USB controller 201 and provide power to USB controller 201.

[0039] Thus, as described above, the same circuit path 240 may allow termination of the signal at node 230 to supply node 290 (through circuit path 240) in both powered and unpowered conditions. This may reduce the number of circuit elements in termination circuit 210, simplify logic control in USB controller 201, or both.

[0040] In FIG. 2, voltage VDD, resistors R1 and R3 can have values to allow termination circuit 210 to provide electrical termination to the signal at node 230 (e.g., CC1 or CC2 pin of a USB Type-C connector) in accordance with USB specification. For example, voltage VDD can have a value of 3.3V or 5V. Resistors R1 and R3 can have values of 36K ohms and 5.1K ohms, respectively. Resistor R2 can have a value significantly less than that of resistor R1. For example, resistor R2 can have a value of approximately 100 ohms. Diode D1 can include a Schottky diode. Switch 225 can include one or more transistors, such as p-channel transistors, n-channel transistors, or a combination of both.

[0041] In some applications, a driver (e.g., a tri-state driver) of a power delivery (PD) controller (not shown in FIG. 2) may drive a signal (e.g., power delivery baseband signal) on node 230. Such a signal at node 230 can swing between 75mV (e.g., logic zero) and 1050mV (e.g., logic one). Such a signal driven by the PD controller can include USB PD Bi-phase Mark Coded communication as defined in USB Power Delivery Specification Revision 2.0, August 11, 2014. USB PD communication is used to establish power contracts between USB devices or systems (e.g., power contracts between apparatus 100 to electronic system 104 in FIG. 1) defined by USB 2.0 and USB 3.1 specifications. USB PD communication is also used to swap the DFP and UFP roles, and to communicate with the USB cable (e.g., USB connection 105 in FIG. 1). The PD controller described herein can be included in an apparatus (e.g., apparatus 100) that includes controller 201 and termination circuits 210. This PD controller (included the apparatus that includes controller 201 and termination circuits 210) may be configured to communicate with another PD controller (e.g., another USB PD controller) in an external system (e.g., electronic system 104) to establish bidirectional PD communication with the external system in accordance with USB Power Delivery Specification.

[0042] In FIG. 2, the arrangement of diode D1 and resistor R3 in circuit path 240 allows such a signal (e.g., power delivery baseband signal) to be driven on node 230 without requiring USB controller 201 to be in powered condition. For example, because of the arrangement of circuit path 240, the voltage at node 230 may not be clamped to a value (e.g., a value close to 1050mV) that may present driving of that signal on node 230. Thus, in addition to providing appropriate electrical termination for the signal at node 230 when USB controller 201 is in an unpowered condition, circuit path 240 may also allow driving of a signal that may swing between logic zero and logic one. As shown in FIG. 2, circuit path 240 may include only a diode (e.g., diode D1) and a resistor (e.g., resistor R3) and may not include a transistor. Thus, USB controller 201 may provide only control signal HOST_SEL to control switch 225 in circuit path 214 in order to control (e.g., change) electrical termination for the signal (e.g., Configuration Channel signal) at node 230 during both USB host and device modes, without providing another control signal (e.g., a second

control signal) to circuit paths 240 and 241 during both USB host and device modes.

[0043] As described above, USB controller 201 may use only one control signal (e.g., HOST_SEL) during both USB host and device modes to control termination circuit 210 in order to change electrical termination of the signal at node 230. For example, as described above, electrical termination of the signal at node 230 can be changed between electrical termination to supply node 291 (e.g., voltage VDD) and electrical termination to supply node 290 (e.g., ground).

[0044] Using only one such control signal (instead of multiple control signals) during both USB host and device modes may simplify implementation (e.g., simplify control logic) for USB controller 201. USB controller 201 may include (e.g., may be formed in or on) an IC chip (e.g., a semiconductor chip or IC package). The single signal (e.g., HOST_SEL), as described above, may reduce (or save) the number of pins of the chip (e.g., IC package) that include USB controller 201. This may reduce chip size, chip cost, and/or allow room for additional pin (or pins) of the chip for other function. Since only one control signal (e.g., HOST_SEL) is used, circuit board area may also be reduced.

[0045] FIG. 3 shows a schematic diagram of a termination circuit 310 that can be a variation of termination circuit 210 in FIG. 2, according to some embodiments described herein. Termination circuit 310 can include elements similar to, or identical to, those of termination circuit 210. Thus, for simplicity, the description of similar or identical elements between termination circuit 210 and 310 is not repeated in the description of termination circuit 310. As shown in FIG. 2 and FIG. 3, differences between circuits 210 and 310 can include a current source 337 in termination circuit 310 of FIG. 3. Current source 337 can replace resistor R1 of termination circuit 210 of FIG. 2.

[0046] Termination circuit 310 can be used as termination circuit 110-1 or 110-2 of FIG. 1. The operation of USB controller 201 and termination circuit 310 in powered and unpowered conditions can be similar to those described above with reference to FIG. 2. In FIG. 3, for example, to operate in USB host mode, switch 225 can be turned on to provide voltage V_{HOST} at node 226 with a value (e.g., 1.7V to 5.5V) sufficient to power current source 337 and cause diode

D1 to be reversed biased. This allows the signal at node 230 of termination circuit 310 to be terminated to supply node 291 in order to allow USB controller 201 of termination circuit 310 to operate in USB host mode.

[0047] To operate in USB device mode, switch 225 of termination circuit 310 can be turned off. Node 226 has high impedance to ground. When a USB unit (e.g., a USB host) is connected to node 230, diode D1 can be forward biased. The signal at node 230 is pulled down to ground through resistor R3. This allows the signal at node 230 of termination circuit 310 of FIG. 3 to be terminated to supply node 290 of termination circuit 310 in order to allow USB controller 201 of termination circuit 310 to operate in USB device mode.

[0048] FIG. 4 shows a schematic diagram of a termination circuit 410 including details of a switch 425, according to some embodiments described herein. Termination circuit 410 can include elements similar to, or identical to, those of termination circuit 210. Thus, for simplicity, the description for similar or identical elements between termination circuit 210 and 410 is not repeated in the description of termination circuit 410. As shown in FIG. 2 and FIG. 4, differences between circuits 210 and 310 include details of switch 425 of termination circuit 410 of FIG. 4.

[0049] Switch 425 can include a transistor (e.g., a p-channel transistor) M1, a transistor (e.g., an n-channel transistor) M2, a resistor R4, and a diode D2 (which can include a Schottky diode).

[0050] Termination circuit 310 can be used as termination circuit 110-1 or 110-2 of FIG. 1. In FIG. 4, the signal at node 230 can be terminated to supply node 291 to allow USB controller 201 to operate in USB host mode when USB controller is in a powered condition. The signal at node 230 can be terminated to supply node 290 to allow USB controller 201 to operate in USB device mode when USB controller is in a powered condition. In an unpowered condition, the signal at node 230 can also be terminated to supply node 290 to allow USB controller 201 to operate as a USB device to receive power from another USB unit.

[0051] In a powered condition, to operate in USB host mode, USB controller 201 in FIG. 4 can drive control signal HOST_SEL to a level (e.g., logic one level) in order to turn on transistor M2. This also turns on transistor

M1. Diode D2 is forward biased. Node 226 is coupled to supply node 291. Thus, voltage V_{HOST} at node 226 can be voltage VDD (e.g., 3.3V). Diode D1 is reversed biased. Thus, node 230 is not coupled to supply node 290. The signal at node 230 is pulled up to voltage V_{HOST} (or voltage VDD at node 291) through resistor R1 in order to allow USB controller 201 of termination circuit 410 to operate in USB host mode.

[0052] In a powered condition, to operate in operate in USB device mode, USB controller 201 of termination circuit 410 can drive control signal HOST_SEL to a level (e.g., logic zero level) in order to turn off transistor M2. Transistor M1 is also turned off. Diode D2 is reversed biased. Node 226 is decoupled from supply node 291 and has high impedance to ground. When a USB unit (e.g., a USB host, such as USB unit 106 in FIG. 1) is connected to node 230, the voltage (e.g., VDD) from the USB unit applied to node 230 can cause diode D1 to be forward biased. The voltage at node 230 is pulled down to ground through resistor R3. This allows the signal at node 230 to be terminated to supply node 290 in order to allow USB controller 201 of termination circuit 410 to operate in USB device mode.

[0053] In an unpowered condition, USB controller 201 and termination circuit 410 can allow a USB unit (e.g., a USB host) to detect connection and provide power to USB controller 201. In an unpowered condition, control signal HOST_SEL can be at zero volts. Transistors M1 and M2 are turned off. Diode D2 blocks reverse current flow from node 230 to supply node 291. This may protect other components that use power provided by supply node 291 from operational failures. When transistors M1 is turned off, node 226 has high impedance to ground. When a USB unit is connected to node 230, the USB unit can detect the connection and provide power to USB controller 201.

[0054] FIG. 4 shows an example where the components (e.g., transistors M1 and M2, resistors R1, R2, R3, and R4, and diodes D1 and D2) of termination circuit 410 are located outside USB controller 201. In an alternative arrangement, a portion (some of the components) of termination circuit 410 can be included in (e.g., located on the same IC chip with) USB controller 201, and another portion of termination circuit 410 can be located on (e.g., soldered to) a circuit board (e.g., circuit board 170 of FIG. 1) and outside USB controller 201.

In another alternative arrangement, all of the components of termination circuit 410 may be included in (e.g., located on the same IC chip with) USB controller 201.

[0055] As shown in FIG. 4, circuit paths 241 and 240 include only one transistor (e.g., transistor M1) between node 230 and one of supply nodes 290 and 291 (e.g., between node 230 and supply node 291). Including only one transistor M1 in circuit paths 240 and 241 may allow only one control signal (e.g., HOST_SEL) to control transistor M1 (e.g., by turning on or off transistor M2 using control signal HOST_SEL). This may simplify control logic in USB controller 201 (FIG. 4), reduce the number of pins (e.g., output pin) of an IC chip that include USB controller 201, or both.

[0056] As described above, diode D2 may protect other components that use power provided by supply node 219 from operational failures. However, the arrangement of transistor M1 on circuit path 241 in FIG. 4 may allow diode D2 to be omitted from termination circuit 410 without causing operational failures to other components that may use power from supply node 291. For example, without diode D2, the voltage across transistor M1 (e.g., voltage across forward biased body diode of transistor M1) may limit the voltage VDD to be at a value that may be acceptable to other components, such that operational failures may not occur.

[0057] FIG. 5 shows an apparatus in the form of an electronic communication system 500, according to some embodiments described herein. System 500 can include or be included in a computer, a cellular phone, or other electronic systems. As shown in FIG. 5, system 500 can include a processor 509, a memory device 520, a memory controller 530, a graphics controller 540, an input and output (I/O) controller 550, a display 552, a keyboard 554, a pointing device 556, at least one antenna 558, termination circuits 510-1 and 510-2, a USB connector 502, and a bus 560. In some arrangements, system 500 does not have to include any antenna. Thus, antenna 558 can be omitted from system 500.

[0058] Processor 509 may include a general-purpose processor or an application specific integrated circuit (ASIC).

[0059] Memory device 520 may include a dynamic random access memory (DRAM) device, a static random access memory (SRAM) device, a flash memory device, or a combination of these memory devices. FIG. 5 shows an example where memory device 520 is a stand-alone memory device separated
5 from processor 509. In an alternative arrangement, memory device 520 and processor 509 can be located on the same die. In such an alternative arrangement, memory device 520 is an embedded memory in processor 509, such as embedded DRAM (eDRAM), embedded SRAM (eSRAM), embedded flash memory, or another type of embedded memory.

10 [0060] Display 552 can include a liquid crystal display (LCD), a touchscreen (e.g., capacitive or resistive touchscreen), or another type of display. Pointing device 556 can include a mouse, a stylus, or another type of pointing device.

[0061] I/O controller 550 can include a communication module for wired
15 or wireless communication (e.g., communication through one or more antenna 558). Such wireless communication may include communication in accordance with WiFi communication technique, Long Term Evolution Advanced (LTE-A) communication technique, or other communication techniques.

[0062] I/O controller 550 can also include a module (e.g., a USB
20 controller) to allow system 500 to communicate with other devices or systems in accordance with USB specification. For example, I/O controller 550 can include a USB controller, which can be any of the USB controllers (e.g., USB controller 101 or 201) described above with reference to FIG. 2 through FIG. 4.

[0063] Each of termination circuits 510-1 and 510-2 can include any of
25 the termination circuits (e.g., 210, 310, and 410) described above with reference to FIG. 2 through FIG. 4. USB connector 502 can include USB connector 102 of FIG. 1. I/O controller 550 (which can include a USB controller) and termination circuits 510-1 and 510-2 can be arranged to operate in ways similar to, or identical, to those of any of the USB controllers and termination circuits
30 described above with reference to FIG. 2 through FIG. 4.

[0064] FIG. 5 shows the components of system 500 arranged separated from each other as an example. In some arrangements, two or more components (processor 509, memory device 520, and I/O controller 550) of system 500 can

be located on the same die (e.g., same IC chip) that forms a system-on-chip (SoC).

[0065] FIG. 6 is flowchart showing a method 600 of operating an electronic communication device or system, including a USB device or system, according to some embodiments described herein. The USB device or system used in method 600 can include a USB controller described above with reference to FIG. 1 through FIG. 5.

[0066] As shown in FIG. 6, activity 602 of method 600 can include terminating a signal at a node to a supply node (e.g., voltage VDD) through a circuit path during a mode (e.g., USB host mode) of the USB controller. The supply node and circuit path in activity 602 can include supply node 191 or 291 and circuit path 141 or 241 described above with reference to FIG. 2 through FIG. 4.

[0067] Activity 604 of method 600 can include terminating the signal at the node to another supply node (e.g., ground) through another circuit path during another mode (e.g., USB device mode) of the USB controller. The supply node and circuit path in activity 604 can include supply node 190 or 290 and circuit path 140 or 240 described above with reference to FIG. 2 through FIG. 4.

[0068] In activities 602 and 604, terminating the signal during the modes (e.g., both USB host and device modes) of the USB controller can include providing a control signal from the USB controller to the circuit paths during the modes of the USB controller to control at least one transistor in the circuit paths without providing another control signal from the USB controller to the circuit paths during the modes of the USB controller.

[0069] Method 600 can include fewer or more activities than activities 602 and 604 shown in FIG. 6. For example, method 600 can include activities and operations of apparatus 100, USB unit 106, USB controllers 101 and 201, I/O controller 550, termination circuits 110-1, 110-2, 210, 310, and 410, and system 500, described above with reference to FIG. 1 through FIG. 5.

[0070] The illustrations of the apparatuses (e.g., apparatus 100 and system 500) and methods (e.g., operations of apparatus 100 and system 500, and method 600) described above are intended to provide a general understanding of

the structure of different embodiments and are not intended to provide a complete description of all the elements and features of an apparatus that might make use of the structures described herein.

[0071] The apparatuses and methods described above can include or be
5 included in high-speed computers, communication and signal processing
circuitry, single or multi-processor modules, single or multiple embedded
processors, multi-core processors, message information switches, and
application-specific modules including multilayer, multi-chip modules. Such
apparatuses may further be included as sub-components within a variety of other
10 apparatuses (e.g., electronic systems), such as televisions, cellular telephones,
personal computers (e.g., notebook computers, laptop computers, desktop
computers, handheld computers, tablet computers, etc.), workstations, radios,
video players, audio players (e.g., MP3 (Motion Picture Experts Group, Audio
Layer 3) players), vehicles, medical devices (e.g., heart monitor, blood pressure
15 monitor, etc.), set top boxes, and others.

ADDITIONAL NOTES AND EXAMPLES

[0072] Example 1 includes subject matter (such as a device, apparatus, or
machine) comprising a node to couple to a serial bus, and a controller to provide
20 a control signal to one of a first circuit path and a second circuit path in order to
change electrical termination of a signal at the node between a first electrical
termination through the first circuit path during a first mode of the controller and
a second electrical termination through the second circuit path during a second
mode of the controller without providing another control signal from the
25 controller to the first and second circuit paths during the first and second modes.

[0073] In Example 2, the subject matter of Example 1 may optionally
include, wherein the serial bus includes a Universal Serial Bus (USB).

[0074] In Example 3, the subject matter of Example 1 may optionally
include, wherein.

30 [0075] In Example 4, the subject matter of any of Example 1 through
Example 3 may optionally include, wherein.

[0076] Example 5 includes subject matter (such as a device, apparatus, or
machine) comprising a node to couple to a Configuration Channel of a Universal

Serial Bus (USB) connection, a first circuit path to terminate a signal at the node to a first supply node, and a second circuit path including a diode and a resistor to terminate the signal at the node to a second supply node.

5 [0077] In Example 6, the subject matter of Example 5 may optionally include, wherein the diode is arranged to be reversed biased when the signal at the node is terminated to the first supply node.

[0078] In Example 7, the subject matter of Example 5 or Example 6 may optionally include, wherein the diode is arranged to be forward biased when the signal at the node is terminated to the second supply node.

10 [0079] In Example 8, the subject matter of Example 5 may optionally include, wherein the first circuit path includes a current source coupled between the node and the first supply node.

[0080] In Example 9, the subject matter of Example 5 may optionally include, wherein the first circuit path includes an additional diode coupled
15 between the node and the first supply node.

[0081] In Example 10, the subject matter of Example 5 may optionally include, wherein the first supply node is arranged to couple to a positive voltage, and the second supply node is arranged to couple to ground.

[0082] In Example 11, the subject matter of any of Example 5 through
20 Example 10 may optionally include, wherein the first and second circuit paths include only one transistor between the node and one of the first and second supply nodes.

[0083] Example 12 includes subject matter (such as a device, apparatus, or machine) comprising a node to couple to a Configuration Channel of a
25 Universal Serial Bus (USB) connection to receive a signal, a USB controller to provide a control signal to one of a first circuit path and a second circuit path in order to change electrical termination of a signal at the node between a first electrical termination through the first circuit path during USB host mode of the USB controller and a second electrical termination through the second circuit
30 path during USB device mode of the USB controller, wherein the USB controller is arranged to provide the control signal to the first and second circuit paths during the USB host and device modes without providing another control signal from the USB controller to the first and second circuit paths during the

USB host and device modes, a processor coupled to the USB controller, and an antenna coupled to the processor

[0084] In Example 13, the subject matter of Example 12 may optionally include, a USB connector having a first Configuration Channel (CC1) pin and a
5 second Configuration Channel (CC2) pin, wherein the node is coupled to one of the CC1 and CC2 pins.

[0085] In Example 14, the subject matter of Example 12 or Example 13 may optionally include, wherein the second circuit path is arranged to terminate the signal at the node to the second supply node through a resistor included in
10 the second circuit path when the USB controller is a powered condition, and the second circuit path is arranged to terminate the signal at the node to the second supply node through the resistor when the USB controller is in an unpowered condition.

[0086] In Example 15, the subject matter of any of Example 12 through
15 Example 14 may optionally include, wherein one of the first and second circuit paths includes a transistor and a resistor, and at least one of the transistor and the resistor is included in the USB controller.

[0087] In Example 16, the subject matter of Example 12 may optionally include, a circuit board, wherein one of the first and second circuit paths
20 includes a transistor and a resistor, and at least one of the transistor and the resistor is located on the circuit board.

[0088] In Example 17, the subject matter of Example 12 may optionally include, an additional node to couple to the Configuration Channel, and wherein the USB controller is arranged to provide the control signal to one of a third
25 circuit path and a fourth circuit path in order to change electrical termination of a signal at the additional node between a third electrical termination through the third circuit path during the USB host mode and a fourth electrical termination through the fourth circuit path during the USB device mode, wherein the USB controller is arranged to provide the control signal to the third and fourth circuit
30 paths during the USB host and device modes without providing another control signal from the USB controller to the third and fourth circuit paths during the USB host and device modes.

[0089] Example 18 includes subject matter including a method of

operating an electronic communication apparatus, including a USB device or system, the method comprising terminating a signal at a node to a first supply node through a first circuit path during a first mode of a USB controller, and terminating the signal at the node to a second supply node through a second circuit path during a second mode of the USB controller, wherein terminating the signal during the first and second modes includes providing a control signal from the USB controller to the first and second circuit paths during the first and second modes to control at least one transistor in the first and second circuit paths without providing another control signal from the USB controller to the first and second circuit paths during the first and second modes.

[0090] In Example 19, the subject matter of Example 18 may optionally include, providing power to a first pin of a USB connector during the first mode, wherein the node is coupled to a second pin of the USB connector, and the second pin includes a Configuration Channel pin of the USB connector.

[0091] In Example 20, the subject matter of Example 18 or Example 19 may optionally include, receiving power from a first pin of a USB connector during the second mode, wherein the node is coupled to a second pin of the USB connector, and the second pin includes a Configuration Channel pin of the USB connector.

[0092] The subject matter of Example 1 through Example 20 may be combined in any combination.

[0093] The above description and the drawings illustrate some embodiments to enable those skilled in the art to practice the embodiments of the invention. Other embodiments may incorporate structural, logical, electrical, process, and other changes. Examples merely typify possible variations.

Portions and features of some embodiments may be included in, or substituted for, those of other embodiments. Many other embodiments will be apparent to those of skill in the art upon reading and understanding the above description.

[0094] The Abstract is provided to comply with 37 C.F.R. Section 1.72(b) requiring an abstract that will allow the reader to ascertain the nature and gist of the technical disclosure. It is submitted with the understanding that it will not be used to limit or interpret the scope or meaning of the claims. The

following claims are hereby incorporated into the detailed description, with each claim standing on its own as a separate embodiment.

CLAIMS

What is claimed is:

- 5 1. An electronic communication apparatus comprising:
a node to couple to a serial bus; and
a controller to provide a control signal to one of a first circuit path and a
second circuit path in order to change electrical termination of a signal at the
node between a first electrical termination through the first circuit path during a
10 first mode of the controller and a second electrical termination through the
second circuit path during a second mode of the controller without providing
another control signal from the controller to the first and second circuit paths
during the first and second modes.
- 15 2. The apparatus of claim 1, wherein the serial bus includes a Universal
Serial Bus (USB).
3. The apparatus of claim 1, wherein the controller includes a Universal
Serial Bus (USB) controller, and the USB controller is arranged to operate as a
20 USB host during the first mode and as a USB device during the second mode.
4. The apparatus of claim any of claims 1-3, wherein the second circuit path
is arranged to allow a USB unit to detect connection of the node and provide
power to the controller if the controller is in an unpowered condition.
- 25 5. An electronic communication apparatus comprising:
a node to couple to a Configuration Channel of a Universal Serial Bus
(USB) connection;
a first circuit path to terminate a signal at the node to a first supply node;
30 and
a second circuit path including a diode and a resistor to terminate the
signal at the node to a second supply node.

6. The apparatus of claim 5, wherein the diode is arranged to be reversed biased when the signal at the node is terminated to the first supply node.
7. The apparatus of claim 5 or 6, wherein the diode is arranged to be forward biased when the signal at the node is terminated to the second supply node.
8. The apparatus of claim 5, wherein the first circuit path includes a current source coupled between the node and the first supply node.
9. The apparatus of claim 5, wherein the first circuit path includes an additional diode coupled between the node and the first supply node.
10. The apparatus of claim 5, wherein the first supply node is arranged to couple to a positive voltage, and the second supply node is arranged to couple to ground.
11. The apparatus of either claim 5 or 6, wherein the first and second circuit paths include only one transistor between the node and one of the first and second supply nodes.
12. An electronic communication apparatus comprising:
a node to couple to a Configuration Channel of a Universal Serial Bus (USB) connection to receive a signal;
a USB controller to provide a control signal to one of a first circuit path and a second circuit path in order to change electrical termination of a signal at the node between a first electrical termination through the first circuit path during USB host mode of the USB controller and a second electrical termination through the second circuit path during USB device mode of the USB controller, wherein the USB controller is arranged to provide the control signal to the first and second circuit paths during the USB host and device modes without providing another control signal from the USB controller to the first and second circuit paths during the USB host and device modes;

a processor coupled to the USB controller; and
an antenna coupled to the processor.

13. The apparatus of claim 12, further comprising a USB connector having a
5 first Configuration Channel (CC1) pin and a second Configuration Channel
(CC2), wherein the node is coupled to one of the CC1 and CC2 pins.

14. The apparatus of claim 12 or 13, wherein the second circuit path is
arranged to terminate the signal at the node to the second supply node through a
10 resistor included in the second circuit path when the USB controller is a powered
condition, and the second circuit path is arranged to terminate the signal at the
node to the second supply node through the resistor when the USB controller is
in an unpowered condition.

15. 15. The apparatus of either claim 12 or 13, wherein one of the first and
second circuit paths includes a transistor and a resistor, and at least one of the
transistor and the resistor is included in the USB controller.

16. The apparatus of claim 12, further comprising a circuit board, wherein
20 one of the first and second circuit paths includes a transistor and a resistor, and at
least one of the transistor and the resistor is located on the circuit board.

17. The apparatus of claim 12, further comprising:
an additional node to couple to the Configuration Channel; and
25 wherein the USB controller is arranged to provide the control signal to
one of a third circuit path and a fourth circuit path in order to change electrical
termination of a signal at the additional node between a third electrical
termination through the third circuit path during the USB host mode and a fourth
electrical termination through the fourth circuit path during the USB device
30 mode, wherein USB controller is arranged to provide the control signal to the
third and fourth circuit paths during the USB host and device modes without
providing another control signal from the USB controller to the third and fourth
circuit paths during the USB host and device modes.

18. A method for operating an electronic communication apparatus, the method comprising:

terminating a signal at a node to a first supply node through a first circuit
5 path during a first mode of a USB controller; and

terminating the signal at the node to a second supply node through a
second circuit path during a second mode of a the USB controller, wherein
terminating the signal during the first and second modes includes providing a
control signal from the USB controller to the first and second circuit paths
10 during the first and second modes to control at least one transistor in the first and
second circuit paths without providing another control signal from the USB
controller to the first and second circuit paths during the first and second modes.

19. The method of claim 18, further comprising:

15 providing power to a first pin of a USB connector during the first mode,
wherein the node is coupled to a second pin of the USB connector, and the
second pin includes a Configuration Channel pin of the USB connector.

20. The method of claim 18 or 19, further comprising:

20 receiving power from a first pin of a USB connector during the second
mode, wherein the node is coupled to a second pin of the USB connector, and
the second pin includes a Configuration Channel pin of the USB connector.

25

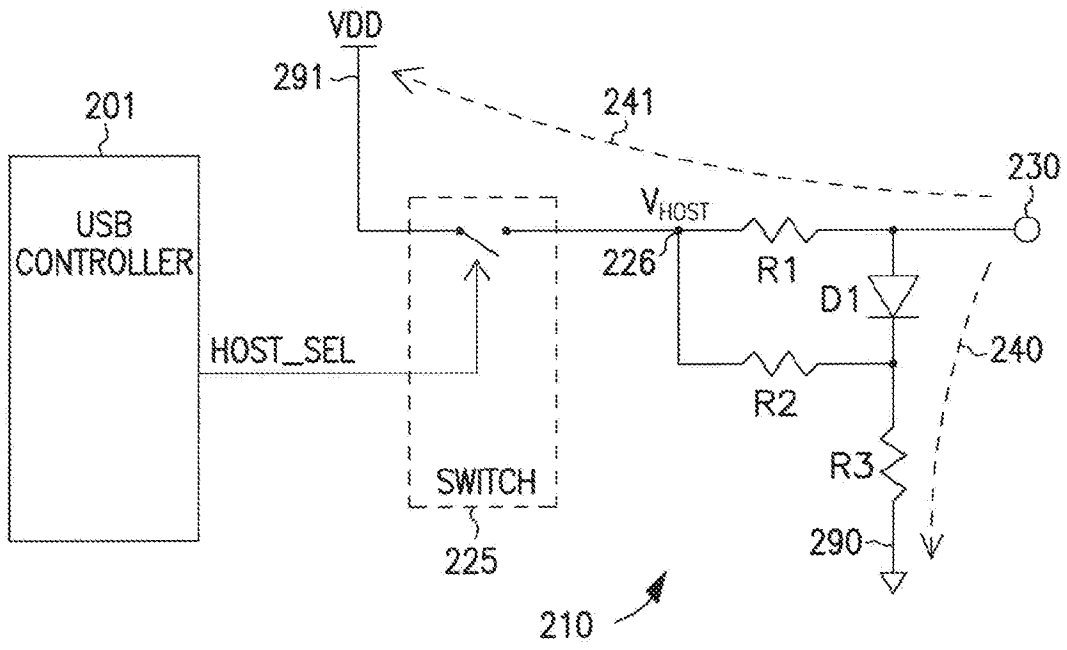

FIG. 2

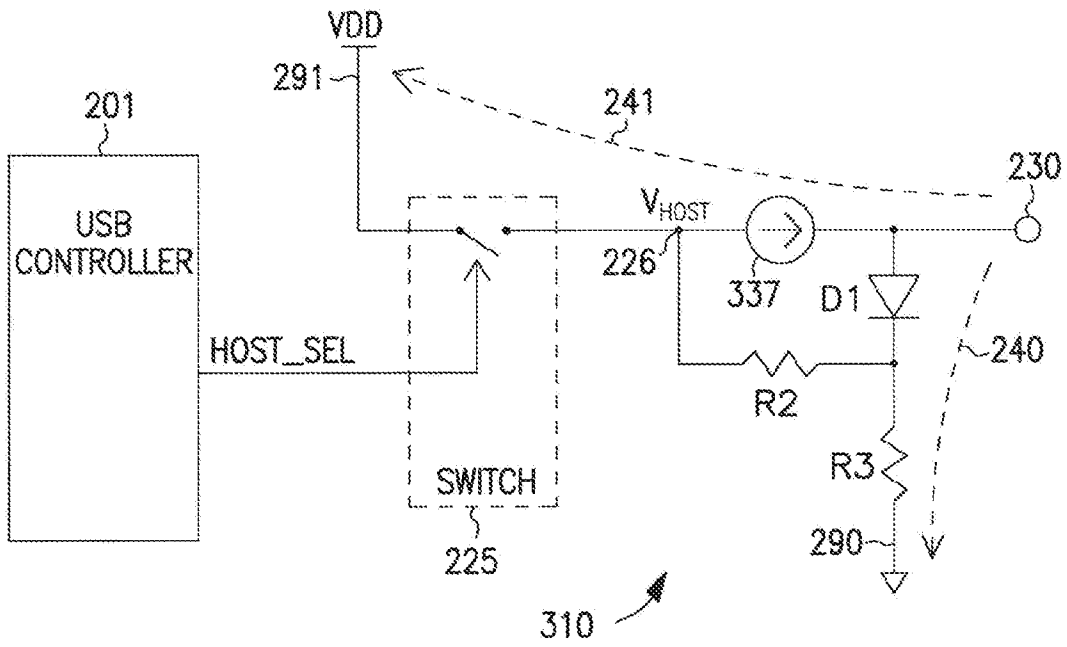

FIG. 3

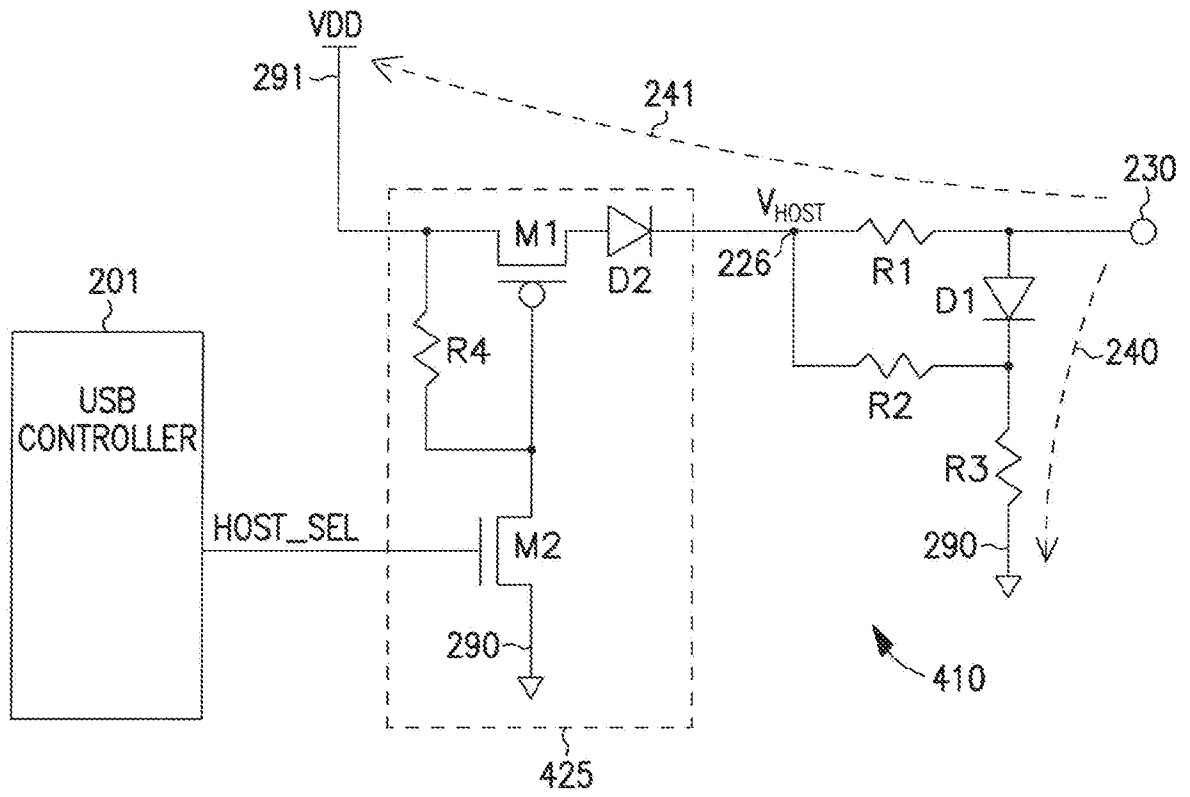
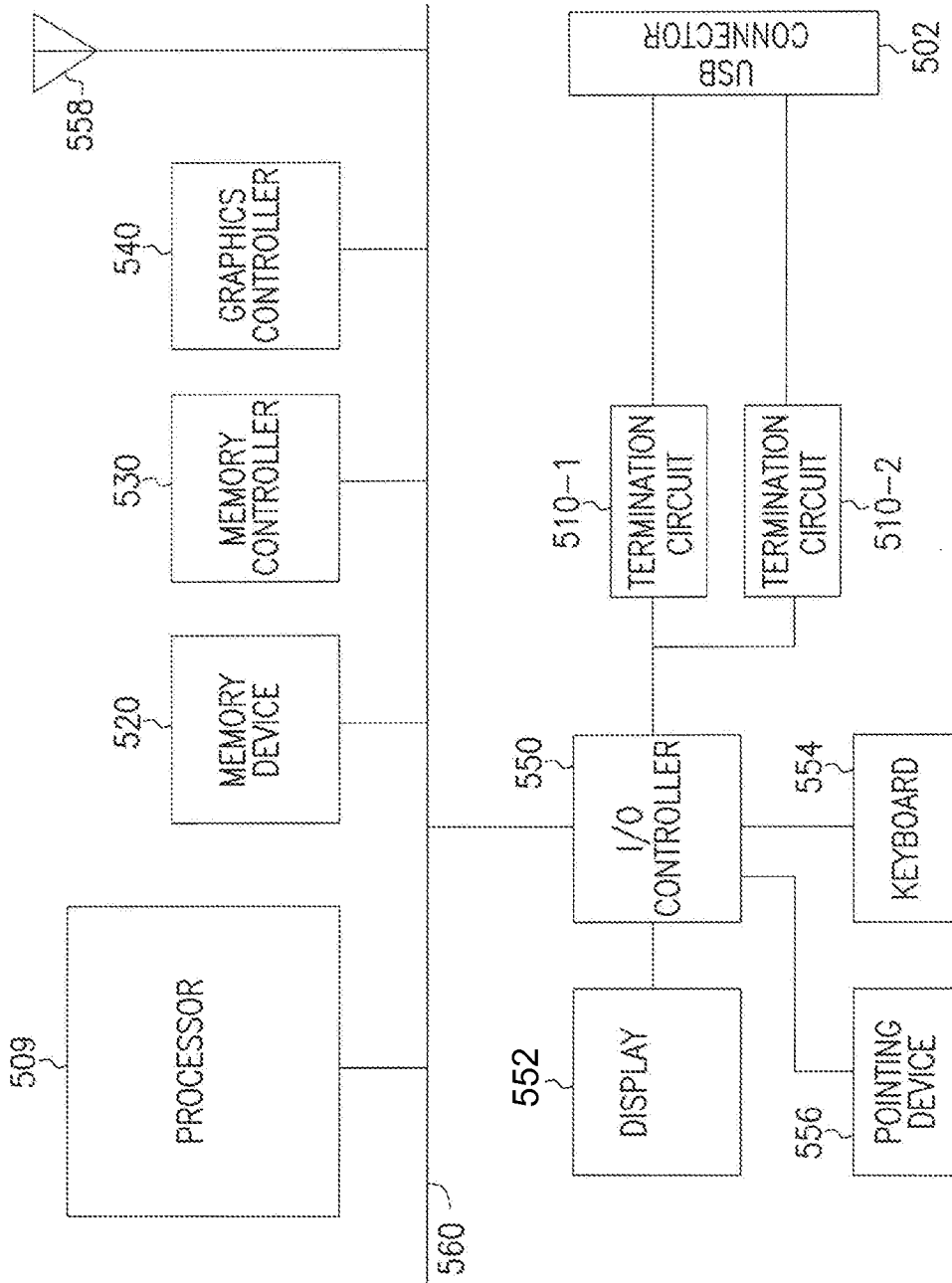
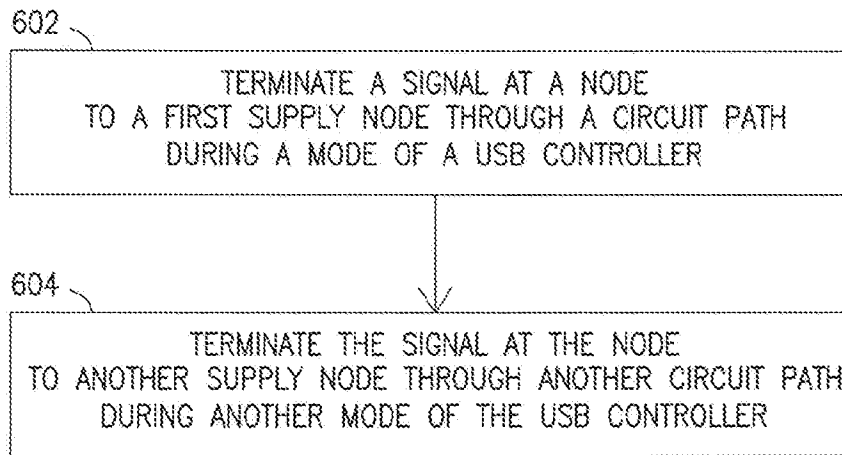

FIG.4



500

FIG. 5



600
FIG. 6

INTERNATIONAL SEARCH REPORT

International application No.
PCT/US2015/049431**A. CLASSIFICATION OF SUBJECT MATTER****G06F 13/42(2006.01)i, G06F 13/38(2006.01)i, G06F 13/40(2006.01)i**

According to International Patent Classification (IPC) or to both national classification and IPC

B. FIELDS SEARCHEDMinimum documentation searched (classification system followed by classification symbols)
G06F 13/42; G06F 3/00; G06F 13/20; G06F 13/00; G06F 13/38; G06F 13/40Documentation searched other than minimum documentation to the extent that such documents are included in the fields searched
Korean utility models and applications for utility models
Japanese utility models and applications for utility modelsElectronic data base consulted during the international search (name of data base and, where practicable, search terms used)
eKOMPASS(KIPO internal) & Keywords: node, serial bus, controller, control signal, circuit path, electrical termination, mode, and similar terms.**C. DOCUMENTS CONSIDERED TO BE RELEVANT**

Category*	Citation of document, with indication, where appropriate, of the relevant passages	Relevant to claim No.
X	US 2004-0148451 A1 (CHING-CHUNG LAI et al.) 29 July 2004 See paragraphs [0001], [0008], [0019]-[0021], and [0025]; claims 1-2, 8-9, and 14; and figures 2-4.	1-4, 18
Y		5-17, 19-20
Y	HEWLETT-PACKARD DEVELOPMENT COMPANY, L. P. et al., "Universal Serial Bus Type-C Cable and Connector Specification," 11 August 2014, < http://www.those.ch/designtechnik/wp-content/uploads/2014/08/USB-Type-C-Specification-Release-1.0.pdf > See page 21, lines 1-3; and figure 2-1.	5-17, 19-20
A	US 2003-0023804 A1 (CHIKARA MATSUDA et al.) 30 January 2003 See paragraphs [0071]-[0077]; and figures 1-2.	1-20
A	WO 2004-012090 A1 (MOTOROLA, INC.) 05 February 2004 See page 5, lines 11-28; and figures 5-6.	1-20
A	US 8,683,085 B1 (JIM CASTLEBERRY et al.) 25 March 2014 See column 2, line 64 - column 3, line 38; and figures 1-2.	1-20

 Further documents are listed in the continuation of Box C. See patent family annex.

* Special categories of cited documents:

"A" document defining the general state of the art which is not considered to be of particular relevance

"E" earlier application or patent but published on or after the international filing date

"L" document which may throw doubts on priority claim(s) or which is cited to establish the publication date of another citation or other special reason (as specified)

"O" document referring to an oral disclosure, use, exhibition or other means

"P" document published prior to the international filing date but later than the priority date claimed

"T" later document published after the international filing date or priority date and not in conflict with the application but cited to understand the principle or theory underlying the invention

"X" document of particular relevance; the claimed invention cannot be considered novel or cannot be considered to involve an inventive step when the document is taken alone

"Y" document of particular relevance; the claimed invention cannot be considered to involve an inventive step when the document is combined with one or more other such documents, such combination being obvious to a person skilled in the art

"&" document member of the same patent family

Date of the actual completion of the international search

15 December 2015 (15.12.2015)

Date of mailing of the international search report

15 December 2015 (15.12.2015)

Name and mailing address of the ISA/KR

International Application Division
Korean Intellectual Property Office
189 Cheongsa-ro, Seo-gu, Daejeon, 35208, Republic of Korea

Facsimile No. +82-42-472-7140

Authorized officer

NHO, Ji Myong

Telephone No. +82-42-481-8528



INTERNATIONAL SEARCH REPORT

Information on patent family members

International application No.

PCT/US2015/049431

Patent document cited in search report	Publication date	Patent family member(s)	Publication date
US 2004-0148451 A1	29/07/2004	TW 200414015 A US 7085876 B2	01/08/2004 01/08/2006
US 2003-0023804 A1	30/01/2003	JP 2003-044186 A JP 3382933 B2 US 6907492 B2	14/02/2003 04/03/2003 14/06/2005
WO 2004-012090 A1	05/02/2004	AU 2003-251788 A1 CN 100336041 C CN 1672139 A EP 1540483 A1 EP 1540483 A4 KR 10-2005-0026011 A US 2004-0019732 A1 US 6732218 B2	16/02/2004 05/09/2007 21/09/2005 15/06/2005 23/08/2006 14/03/2005 29/01/2004 04/05/2004
US 8683085 B1	25/03/2014	US 8924598 B1	30/12/2014