



- (51) International Patent Classification:
A47K 3/02 (2006.01)
- (21) International Application Number:
PCT/US2011/050372
- (22) International Filing Date:
2 September 2011 (02.09.2011)
- (25) Filing Language: English
- (26) Publication Language: English
- (30) Priority Data:
61/413,575 15 November 2010 (15.11.2010) US
- (71) Applicant (for all designated States except US): **MASCO BATH CORPORATION** [US/US]; 540 Glen Avenue, Moorestown, New Jersey 08057 (US).
- (72) Inventors; and
- (75) Inventors/Applicants (for US only): **GEELS, Michael Glenn** [US/US]; 7 Fieldbrook Cove, Jackson, Tennessee 38305 (US). **KAPELANSKI, Scott** [US/US]; 3085 Painted Drive, Howell, Michigan 48843 (US). **MOON, Hyan** [US/US]; 614 Sorrel Court, Bloomfield Hills, Michigan 48304 (US).
- (74) Agent: **DOIGAN, Lloyd D.**; Carlson, Gaskey & Olds PC, 400 W. Maple Road, Suite 350, Birmingham, Michigan 48009 (US).

(81) Designated States (unless otherwise indicated, for every kind of national protection available): AE, AG, AL, AM, AO, AT, AU, AZ, BA, BB, BG, BH, BR, BW, BY, BZ, CA, CH, CL, CN, CO, CR, CU, CZ, DE, DK, DM, DO, DZ, EC, EE, EG, ES, FI, GB, GD, GE, GH, GM, GT, HN, HR, HU, ID, IL, IN, IS, JP, KE, KG, KM, KN, KP, KR, KZ, LA, LC, LK, LR, LS, LT, LU, LY, MA, MD, ME, MG, MK, MN, MW, MX, MY, MZ, NA, NG, NI, NO, NZ, OM, PE, PG, PH, PL, PT, QA, RO, RS, RU, RW, SC, SD, SE, SG, SK, SL, SM, ST, SV, SY, TH, TJ, TM, TN, TR, TT, TZ, UA, UG, US, UZ, VC, VN, ZA, ZM, ZW.

(84) Designated States (unless otherwise indicated, for every kind of regional protection available): ARIPO (BW, GH, GM, KE, LR, LS, MW, MZ, NA, SD, SL, SZ, TZ, UG, ZM, ZW), Eurasian (AM, AZ, BY, KG, KZ, MD, RU, TJ, TM), European (AL, AT, BE, BG, CH, CY, CZ, DE, DK, EE, ES, FI, FR, GB, GR, HR, HU, IE, IS, IT, LT, LU, LV, MC, MK, MT, NL, NO, PL, PT, RO, RS, SE, SI, SK, SM, TR), OAPI (BF, BJ, CF, CG, CI, CM, GA, GN, GQ, GW, ML, MR, NE, SN, TD, TG).

Published:
— with international search report (Art. 21(3))

(54) Title: STRUCTURAL WALL DESIGN OF A COMPOSITE BATHING VESSEL

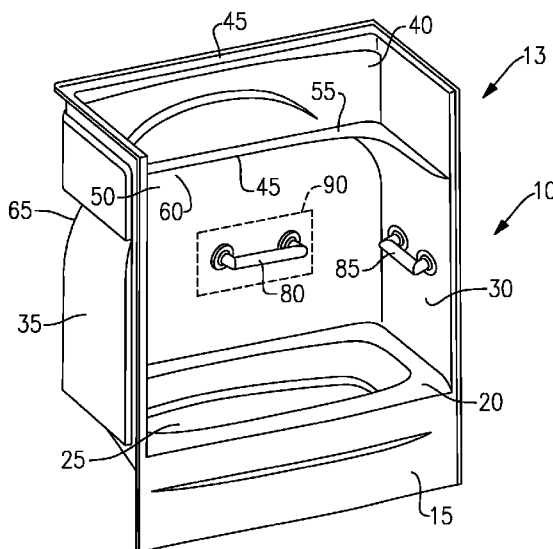

FIG. 1

(57) Abstract: A bathing vessel has a first and a second sandwiched wall, each wall having a first layer of polyurethane material, a second layer of polyurethane material attached to the first layer, a third layer of acrylonitrile butadiene styrene (ABS) material attached to the second layer, and a fourth layer of acrylic material attached to the third layer. A load element is disposed across and is integral with the first and second sandwiched walls. The load element distributes a load on one wall to an other wall and is visible to users of the bathing vessel. The load element is also a design element.

WO 2012/067700 A1

STRUCTURAL WALL DESIGN OF A COMPOSITE BATHING VESSEL

RELATED APPLICATION

[0001] This application claims priority to U.S. Provisional Application No. 61/413,575, which was filed November 15, 2010.

TECHNICAL FIELD

[0001] This disclosure relates to composite bathing vessels.

BACKGROUND

[0001] Bathing vessels such as showers and bathtubs have surrounds that are subject to stresses. The walls may support grab bars and towel bars, and users may interact with the walls of the surrounds by stressing them.

[0002] Bathing vessels may be manufactured from a variety of different materials, such as plastic materials. Plastic bathing vessels, however, must meet certain minimum performance requirements. For instance, the American National Standards Institute (ANSI) sets forth minimum physical requirements and testing methods for plastic bathtub and shower units. A bathing vessel that meets the requirements is approved for use in homes, buildings or other structures as a plumbing fixture.

SUMMARY

[0003] According to an embodiment shown herein, a bathing vessel has a first and a second sandwiched wall, each wall having a first layer of polyurethane material, a second layer of polyurethane material attached to the first layer, a third layer of acrylonitrile butadiene styrene (ABS) material attached to the second layer, and a fourth layer of acrylic material attached to the third layer. A load element is disposed across and is integral with the first and second sandwiched walls. The load element distributes a load on one wall to an other wall and is visible to users of the bathing vessel. The load element is also a design element.

[0004] According to a further embodiment shown herein, a bathing vessel has a first and a second sandwiched wall, each wall having a first layer of polyurethane material, a second layer of polyurethane material attached to the first layer, and a third layer of acrylonitrile butadiene styrene (ABS) material attached to the second layer. A load element is disposed across and is integral with the first and second sandwiched walls. The load element distributes a load on one wall to an other wall and is visible to users of the bathing vessel. The load element is also a design element.

[0005] According to a further embodiment shown herein, a method for constructing a bathing vessel includes the steps of: choosing a layered material defining a first wall and a second wall, the layered material having a first layer of polyurethane material, a second layer of polyurethane material attached to the first layer, and a third layer of acrylonitrile butadiene styrene (ABS) material attached to the second layer; determining a load to be distributed across the first wall and the second wall; forming a load element that is integral with and in the first and second walls that is visible to users, and crosses the first wall and the second wall to distribute the load across the first and the second wall; and, making the load element a design element.

[0006] According to a still further embodiment shown herein, a bathing vessel has a first and a second sandwiched wall and a load element that is integral with and disposed across said first and second sandwiched walls that distributes a load on one wall to the other wall and is visible to users of said bathing vessel wherein said load element is also a design element.

[0007] These and other features of the present invention can be best understood from the following specification and drawings, the following of which is a brief description.

BRIEF DESCRIPTION OF THE DRAWINGS

[0008] Figure 1 is a perspective view of a one piece bathing vessel.

[0009] Figure 2 is a side view of bathing vessel of Figure 1.

[0010] Figure 3 is a detailed view, taken along the lines 3-3 of Figure 2.

[0011] Figure 4 is a detailed view, taken along the lines 4-4 of Figure 2.

[0012] Figure 5 is side view of the material forming the bathing vessel of Figure

1.

[0013] Figure 6 depicts a method of designing a bathing vessel.

DETAILED DESCRIPTION

[0014] Referring now to Figures 1-3, a perspective view of a one-piece bathing vessel 10, including tub 15, a surround 13, a skirt 15 in front of the tub 25, a deck 20 circling a top of the tub, a right sidewall 30 extending upwardly from the deck 20, a left surround wall 35 extending upwardly from the deck 20 and a back wall 40 extending upwardly from the deck 25 and attaching to and integral with the left surround wall 35 and the right surround wall 30. A nailing flange 45 is disposed around the bathing vessel 10 and is used to attach the bathing vessel 10 to a stud wall 70 or an attachment plane 75. A design/load element 50 extends from the left surround wall 35 across the back wall 40 and across to the right side surround wall 30. The curved portion 60 of the design/load element 50 has a back 65. Though a one-piece bathing vessel is shown herein, one of ordinary skill in the art will recognize from the teachings herein, that a one-piece surround made of a side wall(s) and a back wall may also be constructed as taught herein.

[0015] Referring to Figures 2 and 3, details of the design/load element 50 are shown. But for the design element/load element 50, and the nailing flange 45, the back wall 40 and the right and left surround walls 30, 35 are disposed a distance D^1 of .05 inches from a stud wall 70 or an attachment plane 75. Some requirements, such as for ANSI, require the sidewalls 30, 35 or back wall 40 not to deflect more than .25 inch. By keeping these walls less than .25 inch away from the stud wall 70 or attachment plane 75, the distance these walls can deflect is less than .25 inch and the requirements are then met. Because of the flexibility of the walls 35, 40, 30, given the material 57, as will be discussed infra, uses, the D^1 should be less than or equal to .25 inches. The nailing flange 45 and the sidewalls and back walls 35, 40, 30, each have a thickness D^2 of .070 inches.

[0016] The design/load element 50 has a ledge extending around the back wall 40 and the side walls 30, 35 and the curved area 60 also extending around the back wall 40 and the side walls 30, 35. As seen in Figure 4, the design/load element 50 is defined from behind the bathing vessel 10. The curved area 60 helps give the design load element a better aesthetic look and feel to a user. The ledge 55 has a width D^3 of 1.69 inches. By creating the ledge and the curved area in conjunction with a material 57 as will be discussed infra, stresses

on the back wall 40 and the side walls 30, 35 are absorbed into the design/load element 50 and distributed across the back wall 40 and the side walls 30, 35. As a result, less material 57 may be utilized to effect a cost benefit for the bathing vessel 10. Though a particular design/load element 50 is disclosed herein, other design/load element 50 are contemplated herein. The ledge 55 and curved area 60 bisect a span of each of the walls to shorten the span of the wall area holding the loads 80, 85 to facilitate increased rigidity while minimizing material requirements.

[0017] Referring to Figure 5, The bathing vessel 10 is made of a material that is flexible yet rigid so that point loads on the walls such as grab bar 80 or grab bar 85 which typically require extensive local reinforcement 90 (see Figure 1), which may be a metallic panel that may attach to the studs 70, do not require extensive local reinforcement of the back wall 40 or the side walls 30, 35 because the point load is distributed through the design/load element 50 across the sidewalls 30, 35 and the back wall 40.

[0018] The material must be flexible and rigid to enable the load to be distributed across the back wall 40, left side wall 35 and the right side wall 30. Figure 4 shows a cross-section through a portion of one of the walls 35. The walls 35 are a multi-layer structure that generally includes a first layer of polyurethane material 130a, a second layer of polyurethane material 130b, a layer of acrylonitrile butadiene styrene (ABS) material 130c, and a layer of acrylic material 130d (collectively layers 130a-d), such as polymethylmethacrylate. As shown, the layer of acrylic material 130d is a top layer and is exposed for view to a user within the bathing vessel 20. The layers 130b and 130c are intermediate layers, and the layer 130a is a bottommost layer that is generally obscured from view of a user within the bathing vessel 10. Each of the layers 130a-d is bonded to its respective neighboring layer or layers. In embodiments, the specific materials and order of the layers 130a-d contributes to providing the bathing vessel with a desired degree of strength, such as to meet ANSI requirements.

[0019] In embodiments, the layer of acrylic material 130d is arranged on the first layer of polyurethane material 130a, the layer of acrylonitrile butadiene styrene (ABS) material 130c is arranged between the layer of acrylic material 130d and the first layer of polyurethane material 130a, and the second layer of polyurethane material 130b is arranged between the layer of ABS material 130c and the first layer of polyurethane material 130a. In some examples, additional layers may be arranged among the layers 130a-d. In other

examples, the walls 35 include only the layers 130a-d and are free of other layers, materials, adhesives, or the like.

[0020] The thicknesses of the individual layers 130a-d is not necessarily shown to scale and may vary, depending on the desired wall strength and location in the wall 35, for example. In embodiments, the ratio of the thickness of the layer of acrylic material 130d to the thickness of the layer of ABS material is no greater than 1, to facilitate meeting strength requirements.

[0021] In embodiments, the first layer of polyurethane material 130a, the second layer of polyurethane material 130b, or both, are foamed polyurethane materials. In some examples, the density of the first layer of polyurethane material 130a is different than the density of the second layer of polyurethane material 130b. For instance, the density of the first layer of polyurethane material 130a is greater than the density of the second layer of polyurethane material 130b, to facilitate achievement of a desired degree of strength of the walls 35.

[0022] In a further example, the second layer of polyurethane material 130b is a rigid layer and has a density of 1-10 pounds per cubic foot. The first layer of polyurethane material 130a is an elastomeric layer and has a density of between about 25-65 pounds per cubic foot though in some examples approximately 55-65 pounds per cubic foot are used. In one example, the density is approximately 62 pounds per cubic foot.

[0023] Referring now to Figure 6, local requirements, such as ANSI standards, may require walls 30, 35, 40, to withstand point or other loads that have heretofore required extensive local reinforcement. If designing or constructing a bathing vessel 10 herein, a designer may choose to use the material 57 herein (step 95). The designer would then design a load element such as ledge 55, taking into account the following variables: finite element analysis or the like how stresses of point loads are distributed around walls 30, 35, 40 in view of a proposed design (step 110); minimizing material 57 required as the design evolves (step 115) and minimizing local reinforcement 90 required (step 105). The designer then provides and aesthetic (step 120), such as curved area 60, to make the bathing vessel attractive to consumers. By understanding that the material helps distribute the point or other loads with the inclusion of a design/load element 50, the designer may include a design/load element 50 that is both aesthetic and provides support for the loads across the walls 30, 35, 40. After

designing a design/load element 50, the designer may then opt for smaller local reinforcement, or a thinner material 57.

[0024] It is commonly believed and accepted that the load displacement of the surface of the walls 30, 35, 40, of the bathing vessel 10 is a function of the rigidity of the immediate area. However, it has been determined that by using less rigid materials, a load can be distributed throughout the unit by use of a design element that ties the walls together. In other words, a wrap around shelf or other design feature that has continuity across the back wall surface in carrying through the corner radius and onto each sidewall, can distribute the load across the entire unit. By distributing the load across the entire unit, thinner material may be used, allowing weight in material savings.

[0025] Furthermore, the embodiments shown utilize design elements to shorten the span of the wall area to facilitate increased rigidity while minimizing material requirements. In addition, the wall design elements use a minimum distance from the stud plane (or installation alcove surface) at key loading points to minimize the maximum deflection of the walls of the bathing vessel.

[0026] Although a combination of features is shown in the illustrated examples, not all of them need to be combined to realize the benefits of various embodiments of this disclosure. In other words, a system designed according to an embodiment of this disclosure will not necessarily include all of the features shown in any one of the Figures or all of the portions schematically shown in the Figures. Moreover, selected features of one example embodiment may be combined with selected features of other example embodiments.

[0027] The preceding description is exemplary rather than limiting in nature. Variations and modifications to the disclosed examples may become apparent to those skilled in the art that do not necessarily depart from the essence of this disclosure. The scope of legal protection given to this disclosure can only be determined by studying the following claims.

CLAIMS

What is claimed is:

1. A bathing vessel, said vessel comprising:
 - a first and a second sandwiched wall having
 - a first layer of polyurethane material,
 - a second layer of polyurethane material attached to said first layer,
 - a third layer of acrylonitrile butadiene styrene (ABS) material attached to said second layer, and
 - a fourth layer of acrylic material attached to said third layer,
 - a load element disposed across and is integral with said first and second sandwiched walls that distributes a load on one wall to other walls and is visible to users of said bathing vessel wherein said load element is also a design element.
2. The bathing vessel of claim 1 wherein said load element is also a design element.
3. The bathing vessel of claim 1 wherein further comprising said load element is a portion attaching perpendicularly at an inner edge thereof and integrally to said first wall and said second wall and passing across a corner between the first wall and second wall.
4. The bathing vessel of claim 3 wherein said load element further comprises a curved area disposed integrally in and extending outwardly from said first wall and said second wall and across a corner between the first wall and second wall, said curved area blending from said first wall and said second wall into an outer edge of said portion.

5. The bathing vessel of claim 1 further comprising said load element is a curved area disposed integrally in and extending outwardly from said first wall and said second wall and across a corner between the first wall and second wall.
6. The bathing vessel of claim 1 further comprising a load disposed in one of said first wall or said second wall.
7. The bathing vessel of claim 1 further comprising a nailing flange disposed across and outer edge of said first wall and said second wall wherein a distance between an outer edge of said nailing flange and a back of said first wall and said second wall is less than or equal to .25 inches.
8. The bathing vessel of claim 1 wherein said load element passes across and is integrally attached to a corner between said first and second sandwiched walls.
9. The bathing vessel of claim 1 wherein said load element is horizontal.

10. A bathing vessel, said vessel comprising:
 - a first and a second sandwiched wall having
 - a first layer of polyurethane material,
 - a second layer of polyurethane material attached to said first layer, and
 - a third layer of acrylonitrile butadiene styrene (ABS) material attached to said second layer,
 - a load element that is integral with and disposed across said first and second sandwiched walls that distributes a load on one wall to the other wall and is visible to users of said bathing vessel wherein said load element is also a design element.
11. The bathing vessel of claim 10 wherein further comprising said load element is a portion attaching perpendicularly at an inner edge thereof and integrally to said first wall and said second wall and passing across a corner between the first wall and second wall.
12. The bathing vessel of claim 11 wherein said load element further comprises a curved area disposed integrally in and extending outwardly from said first wall and said second wall and across a corner between the first wall and second wall, said curved area blending from said first wall and said second wall into an outer edge of said portion.
13. The bathing vessel of claim 10 further comprising said load element is a curved area disposed integrally in and extending outwardly from said first wall and said second wall and across a corner between the first wall and second wall.
14. The bathing vessel of claim 10 further comprising a load disposed in one of said first wall or said second wall.

15. The bathing vessel of claim 10 further comprising a nailing flange disposed across an outer edge of said first wall and said second wall wherein a distance between an outer edge of said nailing flange and a back of said first wall and said second wall is less than or equal to .25 inches.

16. The bathing vessel of claim 10 wherein said load element passes across and is integrally attached to a corner between said first and second sandwiched walls.

17. The bathing vessel of claim 10 wherein said load element is horizontal.

18. A method for constructing a bathing vessel comprising the steps of:
choosing a layered material defining a first wall and a second wall, the layered material having a first layer of polyurethane material, a second layer of polyurethane material attached to said first layer, and a third layer of acrylonitrile butadiene styrene (ABS) material attached to said second layer, determining a load to be distributed across the first wall and the second wall, forming a load element that is integral with and in said first and second walls that is visible to users, and crosses said first wall and said second wall to distribute said load across said first and said second wall, and making said load element a design element.
19. The method of claim 18 wherein said forming a load element further comprises passing said load element across and integrally attaching said load element to a corner between said first and second sandwiched walls.
20. The method of claim 18 wherein said forming said load element step includes forming said load element horizontally across said first and second wall.

21. A bathing vessel, said vessel comprising:

a first and a second sandwiched wall

a load element that is integral with and disposed across said first and second sandwiched walls that distributes a load on one wall to the other wall and is visible to users of said bathing vessel wherein said load element is also a design element.

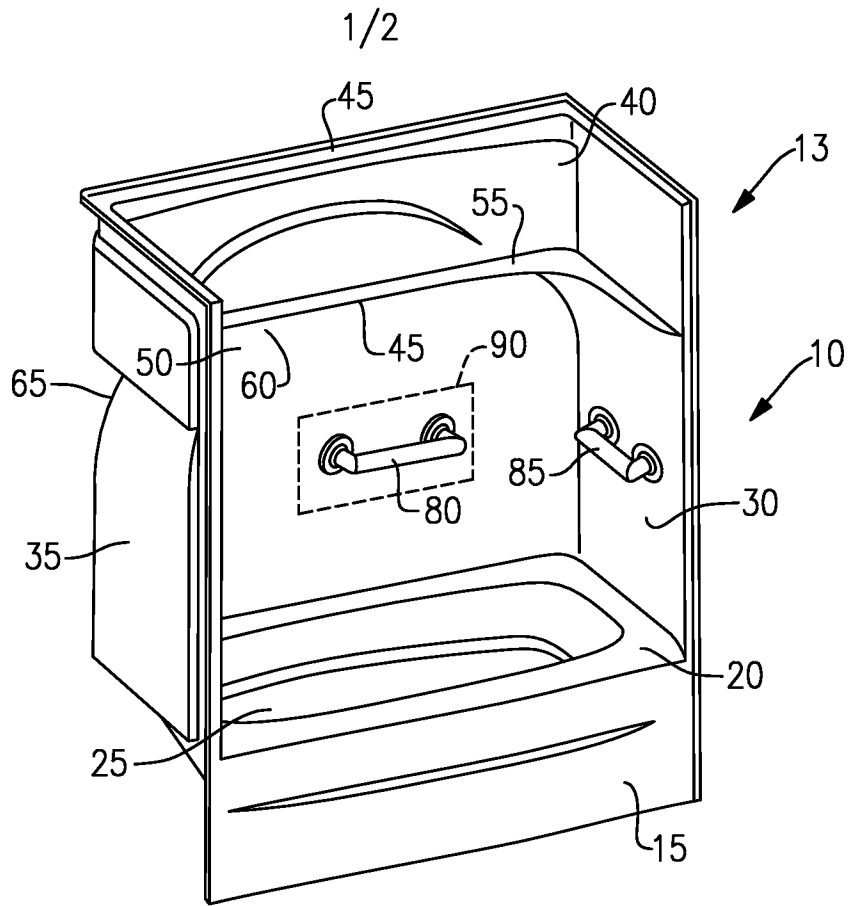

FIG. 1

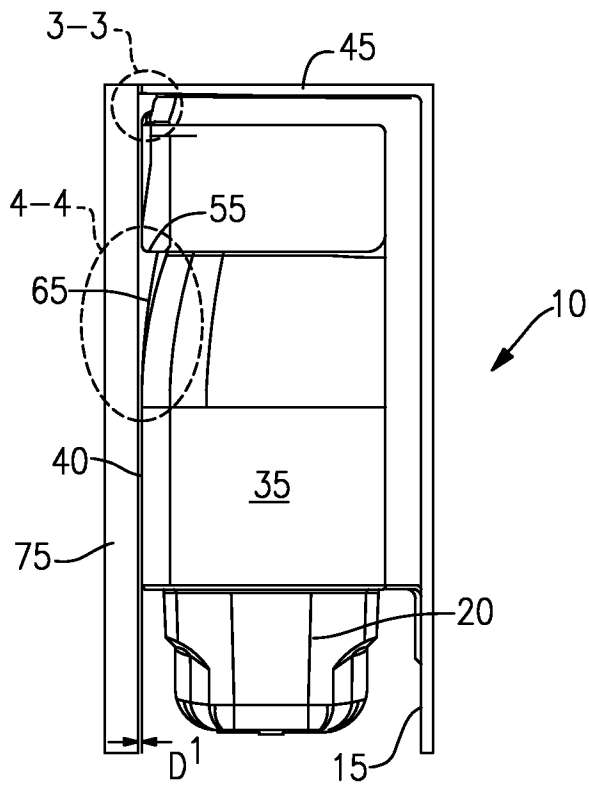

FIG. 2

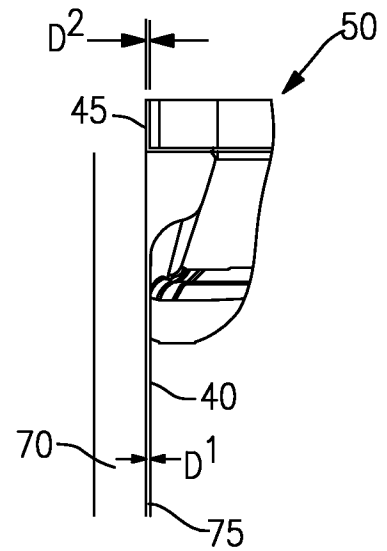

FIG. 3

2/2

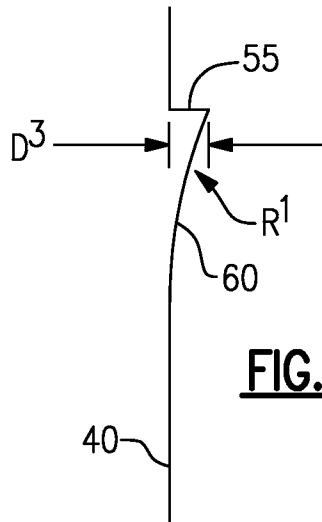

FIG. 4

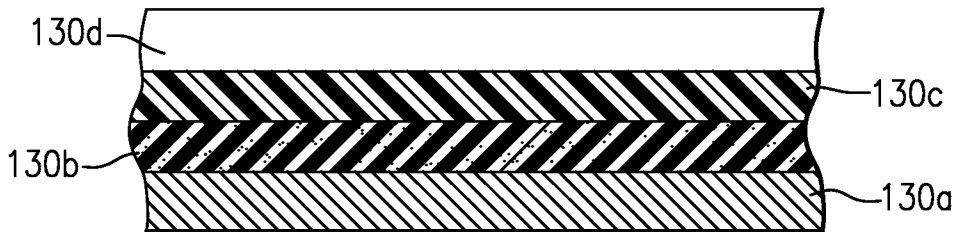

FIG. 5

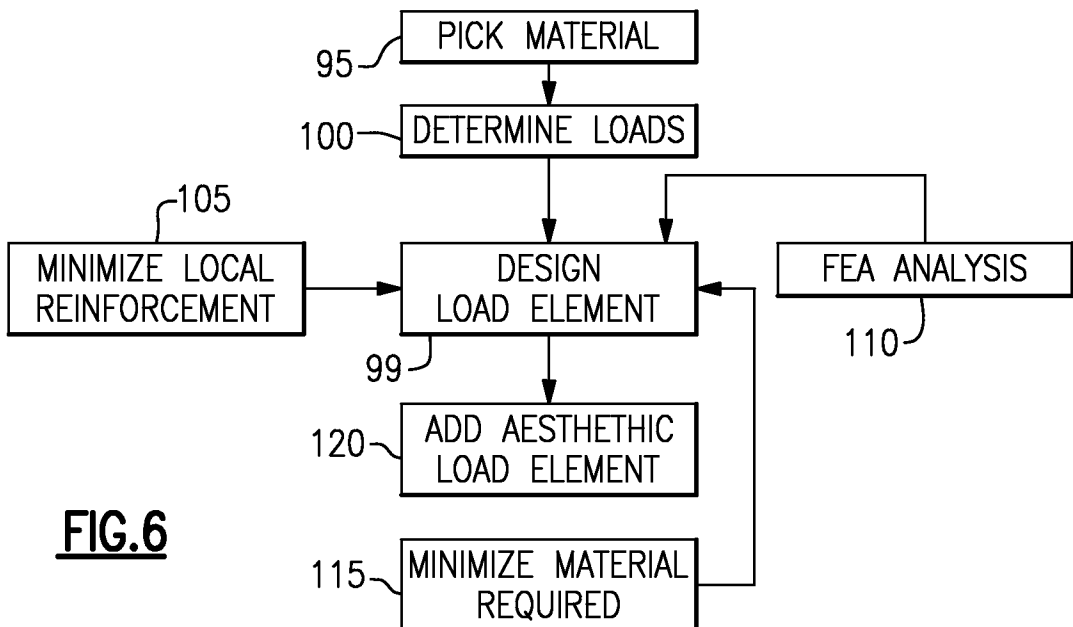

FIG. 6

INTERNATIONAL SEARCH REPORT

International application No.

PCT/US 11/50372

A. CLASSIFICATION OF SUBJECT MATTER IPC(8) - A47K 3/02 (2012.01) USPC - 4/584 According to International Patent Classification (IPC) or to both national classification and IPC		
B. FIELDS SEARCHED Minimum documentation searched (classification system followed by classification symbols) IPC: A47K 3/02 (2012.01) USPC: 4/584 Documentation searched other than minimum documentation to the extent that such documents are included in the fields searched IPC: A47K 3/02 (2012.01) USPC: 4/538, 546, 559, 560.1, 584, 589, 590, 592, 593 Electronic data base consulted during the international search (name of data base and, where practicable, search terms used) PubWEST (PGPB,USPT,EPAB,JPAB), Google (Patents, Web); Keywords: bath\$, tub, vessel, shower, bathtub, wall, side, sandwich\$, layer\$, polyurethane, acrylonitrile, styrene, ABS, acrylic, load, force, shelf, ledge, support, integral\$, corner, curv\$, round\$		
C. DOCUMENTS CONSIDERED TO BE RELEVANT		
Category*	Citation of document, with indication, where appropriate, of the relevant passages	Relevant to claim No.
Y	US 2004/0146714 A1 (McCollum et al.) 29 July 2004 (29.07.2004) para [0041]; claim 50; Fig. 7	1-21
Y	US D336,949 A (Clark et al.) 29 June 1993 (29.06.1993) Abstract; Fig. 1, 3	1-21
Y	US 2010/0212083 A1 (Stafford et al.) 26 August 2010 (26.08.2010) para [0038]	1-21
Y	US 5,778,463 A (Teckchandani et al.) 14 July 1998 (14.07.1998) col 3, ln 13-18; Fig. 1	7, 15
<input type="checkbox"/> Further documents are listed in the continuation of Box C. <input type="checkbox"/>		
* Special categories of cited documents: "A" document defining the general state of the art which is not considered to be of particular relevance "E" earlier application or patent but published on or after the international filing date "L" document which may throw doubts on priority claim(s) or which is cited to establish the publication date of another citation or other special reason (as specified) "O" document referring to an oral disclosure, use, exhibition or other means "P" document published prior to the international filing date but later than the priority date claimed "T" later document published after the international filing date or priority date and not in conflict with the application but cited to understand the principle or theory underlying the invention "X" document of particular relevance; the claimed invention cannot be considered novel or cannot be considered to involve an inventive step when the document is taken alone "Y" document of particular relevance; the claimed invention cannot be considered to involve an inventive step when the document is combined with one or more other such documents, such combination being obvious to a person skilled in the art "&" document member of the same patent family		
Date of the actual completion of the international search 28 January 2012 (28.01.2012)		Date of mailing of the international search report 09 FEB 2012
Name and mailing address of the ISA/US Mail Stop PCT, Attn: ISA/US, Commissioner for Patents P.O. Box 1450, Alexandria, Virginia 22313-1450 Facsimile No. 571-273-3201		Authorized officer: Lee W. Young PCT Helpdesk: 571-272-4300 PCT OSP: 571-272-7774