

(12) INTERNATIONAL APPLICATION PUBLISHED UNDER THE PATENT COOPERATION TREATY (PCT)

(19) World Intellectual Property

Organization

International Bureau

(43) International Publication Date

23 February 2023 (23.02.2023)



(10) International Publication Number

WO 2023/023019 A1

(51) International Patent Classification:

A43B 11/00 (2006.01) A43C 11/00 (2006.01)

A43B 3/00 (2022.01)

EE, ES, FI, FR, GB, GR, HR, HU, IE, IS, IT, LT, LU, LV, MC, MK, MT, NL, NO, PL, PT, RO, RS, SE, SI, SK, SM, TR), OAPI (BF, BJ, CF, CG, CI, CM, GA, GN, GQ, GW, KM, ML, MR, NE, SN, TD, TG).

(21) International Application Number:

PCT/US2022/040411

(22) International Filing Date:

16 August 2022 (16.08.2022)

(25) Filing Language:

English

(26) Publication Language:

English

(30) Priority Data:

63/233,451 16 August 2021 (16.08.2021) US

17/488,032 28 September 2021 (28.09.2021) US

(71) Applicant: ORTHOFEET, INC. [US/US]; 335 Chestnut Street, Norwood, NJ 07648 (US).

(72) Inventor: BAR, Aharon; 1265 15th Street, Fort Lee, NJ 07024 (US).

(74) Agent: SMITH, Gregory Scott; 1055 Prince Avenue, Athens, GA 30606 (US).

(81) Designated States (unless otherwise indicated, for every kind of national protection available): AE, AG, AL, AM, AO, AT, AU, AZ, BA, BB, BG, BH, BN, BR, BW, BY, BZ, CA, CH, CL, CN, CO, CR, CU, CV, CZ, DE, DJ, DK, DM, DO, DZ, EC, EE, EG, ES, FI, GB, GD, GE, GH, GM, GT, HN, HR, HU, ID, IL, IN, IQ, IR, IS, IT, JM, JO, JP, KE, KG, KH, KN, KP, KR, KW, KZ, LA, LC, LK, LR, LS, LU, LY, MA, MD, ME, MG, MK, MN, MW, MX, MY, MZ, NA, NG, NI, NO, NZ, OM, PA, PE, PG, PH, PL, PT, QA, RO, RS, RU, RW, SA, SC, SD, SE, SG, SK, SL, ST, SV, SY, TH, TJ, TM, TN, TR, TT, TZ, UA, UG, US, UZ, VC, VN, WS, ZA, ZM, ZW.

(84) Designated States (unless otherwise indicated, for every kind of regional protection available): ARIPO (BW, GH, GM, KE, LR, LS, MW, MZ, NA, RW, SD, SL, ST, SZ, TZ, UG, ZM, ZW), Eurasian (AM, AZ, BY, KG, KZ, RU, TJ, TM), European (AL, AT, BE, BG, CH, CY, CZ, DE, DK,

Published:

— with international search report (Art. 21(3))

(54) Title: AN EASY-ENTRY SHOE WITH A SPRING-FLEXIBLE REAR

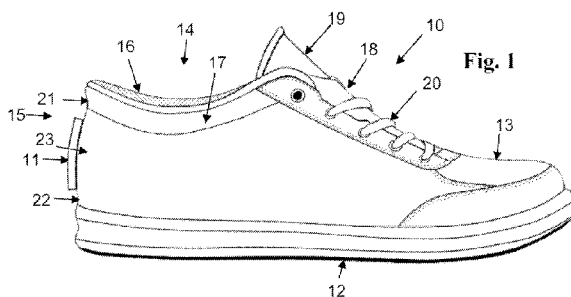

(57) Abstract: A shoe including a sole and a shoe upper, the shoe upper including a shoe opening for entering the shoe, the shoe opening defined by a rear part, a medial part, a lateral part, and a front part, the rear part including a top portion, reinforced by a firm material, an optional bottom portion reinforced by a firm material, a center portion, located between the top portion and the bottom portion, the center portion made of a flexible material, and a spring element. The top part of the spring element being attached to the top portion of the rear part, and the bottom part of the spring element being attached to either the bottom portion of the rear part, or to the sole.



WO 2023/023019 A1

AN EASY-ENTRY SHOE WITH A SPRING-FLEXIBLE REAR**CROSS-REFERENCE TO RELATED APPLICATIONS**

[0001] This is a utility application being filed in the United States as a non-provisional application for patent under Title 35 U.S.C. § 100 et seq. and 37 C.F.R. § 1.53(b) and, claiming the benefit of the prior filing date under Title 35, U.S.C. §119(e) of the United States provisional application for patent that was filed on August 16, 2021 and assigned serial number 63/233,451, which application is incorporated herein by reference in its entirety.

FIELD

[0002] The field of the present disclosure and the related embodiments relate to the field of footwear, and, more particularly but not exclusively, to footwear, such as a shoe, enabling easy entry of a foot into the shoe.

BACKGROUND

[0003] A significant number of users have difficulties bending down to help put on shoes with closed heel design. However, when putting shoes on and taking them off, most shoes require bending down to lace or unlace the shoe, or help adjusting the rear part of the shoe to enter slip-on shoes. There is thus a widely recognized need for a shoe that enables a user to put it on and take it off without the need for bending down and employing the use of the user's hands.

[0004] Many such easy-entry shoe are disclosed, such as disclosed in US patents US1686175, US9675132, US9820527, US9877542, US10306947, US10506842, US10555578, US10638810, US10653209, US10660401, US10813405, US10842222, US10905192, US10973279, and US application US20210106094, as well as PCT application WO2012077899. These solutions involve compression of the rear side of the shoe to enable the foot to enter the shoe, and a spring element that returns the compressed rear side to upright position. However, these constructions are costly to manufacture and uncomfortable to wear because of the rigid structure around the heel. Therefore, there

is a need for a shoe with a more simplified construction that is easier and inexpensive to produce.

SUMMARY

- [0005] According to one exemplary embodiment there is provided an article of wear such as a shoe including a sole and a shoe upper, the shoe upper including a shoe opening for entering the shoe, the shoe opening defined by a rear part, a medial part, a lateral part, and a front part, the rear part including a top portion, reinforced by a firm material, a bottom portion, reinforced by a firm material, a center portion, located between the top portion and the bottom portion, the center portion made of a flexible material, and a spring element. The top part of the spring element being attached to the top portion of the rear part, and the bottom part of the spring element being attached to the bottom portion of the rear part.
- [0006] According to another exemplary embodiment there is provided an article of wear such as a shoe including shoe including a sole and a shoe upper, the shoe upper including a shoe opening for entering the shoe, the shoe opening defined by a rear part, a medial part, a lateral part, and a front part, the rear part including a top portion, reinforced by a firm material, a flexible material, located between the top portion and the sole, and a compression spring element. The top part of the compression spring element being attached to the top portion of the rear part, and the bottom part of the compression spring element being attached to the sole.
- [0007] According to still another exemplary embodiment there is provided an article of wear such as a shoe where the spring element is made of a circular compression spring.
- [0008] According to yet another exemplary embodiment there is provided an article of wear such as a shoe where the spring element is made of a garter compression spring.
- [0009] Further according to another exemplary embodiment there is provided an article of wear such as a shoe where the spring element is made of a sinusoidal compression spring.
- [0010] Still further according to another exemplary embodiment there is provided an article of wear such as a shoe where at least one of the medial part and the lateral part of the shoe includes an elastic element.

- [0011] Yet further according to another exemplary embodiment there is provided an article of wear such as a shoe where the spring element is mounted vertically, at the horizontal middle of the rear part of the shoe.
- [0012] Even further, according to another exemplary embodiment there is provided an article of wear such as a shoe where the spring element is curved vertically, upwards and forward, according to vertical curvature of the rear part of the shoe; and/or curved horizontally according to horizontal curvature of the rear part of the shoe.
- [0013] Additionally, according to another exemplary embodiment there is provided a method for entering a shoe, including the steps of providing a shoe including a sole and a shoe upper, the shoe upper including a shoe opening for entering the shoe, the shoe opening defined by a rear part, a medial part, a lateral part, and a front part, Where the rear part of the shoe includes a top portion reinforced by a firm material, a bottom portion reinforced by a firm material, a center portion between the top portion and the bottom portion, the center portion made of a flexible material, and a compression spring element. Where the top part of the compression spring element is attached to the top portion of the rear part, and the bottom part of the compression spring element is attached to the bottom portion of the rear part. Exerting a downward force on the top portion of the rear part when a foot enters the shoe to push down the top portion of the rear part, and creating enough space for the foot to enter the shoe. And releasing the downward force on the top portion of the rear part to enable the compression spring element to push the top portion of the rear part up for securing the foot in the shoe.
- [0014] According to still another exemplary embodiment there is provided a method for entering a shoe, including the steps of providing a shoe including a sole and a shoe upper, the shoe upper including a shoe opening for entering the shoe, the shoe opening defined by a rear part, a medial part, a lateral part, and a front part, Where the rear part of the shoe includes a top portion reinforced by a firm material, a center portion between the top portion and the bottom portion, the center portion made of a flexible material, and a compression spring element. Where the top part of the compression spring element is attached to the top portion of the rear part, and the bottom part of the compression spring element is attached to the sole of the shoe. Exerting a downward

force on the top portion of the rear part when a foot enters the shoe to push down the top portion of the rear part and creating enough space for the foot to enter the shoe. And releasing the downward force on the top portion of the rear part to enable the compression spring element to push the top portion of the rear part up for securing the foot in the shoe.

[0015] Unless otherwise defined, all technical and scientific terms used herein have the same meaning as commonly understood by one of ordinary skill in the relevant art. The materials, methods, and examples provided herein are illustrative only and not intended to be limiting. Except to the extent necessary or inherent in the processes themselves, no particular order to steps or stages of methods and processes described in this disclosure, including the figures, is intended or implied. In many cases the order of process steps may vary without changing the purpose or effect of the methods described.

[0016] Implementation of the method and system of embodiments disclosed below involves performing or completing certain selected tasks or steps manually, automatically, or any combination thereof. Moreover, according to actual instrumentation and equipment of preferred embodiments of the method and system presented herein several selected steps could be implemented by hardware or by software on any operating system of any firmware or any combination thereof. For example, as hardware, selected steps could be implemented as a chip or a circuit. As software, selected steps could be implemented as a plurality of software instructions being executed by a computer using any suitable operating system. In any case, selected steps of the method and system disclosed herein could be described as being performed by a data processor, such as a computing platform for executing a plurality of instructions.

BRIEF DESCRIPTION OF THE DRAWINGS

- [0017] Various embodiments are described herein, by way of example only, with reference to the accompanying drawings. With specific reference now to the drawings in detail, it is stressed that the particulars shown are by way of example and for purposes of illustrative discussion of the preferred embodiments only, and are presented in order to provide what is believed to be the most useful and readily understood description of the principles and conceptual aspects of the embodiment. In this regard, no attempt is made to show structural details of the embodiments in more detail than is necessary for a fundamental understanding of the subject matter, the description taken with the drawings making apparent to those skilled in the art how the several forms and structures may be embodied in practice.
- [0018] In the drawings:
- [0019] Fig. 1 is a simplified illustration of a side view of an easy entry footwear with a rear spring;
- [0020] Fig. 2A is a simplified illustration of a rear view of the interior of rear part of an easy entry footwear with a circular rear spring;
- [0021] Fig. 2B is a simplified illustration of a rear view of the interior of rear part of an easy entry footwear with a garter rear spring;
- [0022] Fig. 3A is a simplified illustrations of a rear view of the interior of rear part of the easy entry footwear, with rear spring of an open circular shape with its two edges not connected to each other, and in uncompressed mode;
- [0023] Fig. 3B is a simplified illustrations of a rear view of the interior of rear part of the easy entry footwear, with rear spring of an open circular shape with its two edges not connected to each other, and in compressed mode;
- [0024] Fig. 4A is a simplified illustrations of a rear view of the interior of rear part of the easy entry footwear, with a sinusoidal compression spring, in uncompressed mode;
- [0025] Fig. 4B is a simplified illustrations of a rear view of the interior of rear part of the easy entry footwear, with a sinusoidal compression spring, in compressed mode;

[0026] Fig. 5A is a simplified illustration of a side view of the easy entry footwear with rear part in an uncompressed position, and with an elastic element in an unstretched position; and

[0027] Fig. 5B is a simplified illustration of a side view of the easy entry footwear with rear part in a compressed position, and with an elastic element in a stretched position.

DESCRIPTION OF EMBODIMENTS

[0028] The principles and structure according to some embodiments of a footwear, such as a laced shoe or a slip-on shoe, providing easy entry of the user's foot, may be better understood with reference to the drawings and accompanying description.

[0029] Before explaining at least one embodiment in detail, it is to be understood that the embodiments are not limited in their application to the details of construction and the arrangement of the components set forth in the following description or illustrated in the drawings. Other embodiments may be practiced or carried out in various ways. Also, it is to be understood that the phraseology and terminology employed herein is for the purpose of description and should not be regarded as limiting.

[0030] In this document, an element of a drawing that is not described within the scope of the drawing and is labeled with a numeral that has been described in a previous drawing has the same use and description as in the previous drawings. Similarly, an element that is identified in the text by a numeral that does not appear in the drawing described by the text, has the same use and description as in the previous drawings where it was described.

[0031] The drawings in this document may not be to any scale. Different drawings may use different scales and different scales can be used even within the same drawing, for example different scales for different views of the same object or different scales for the two adjacent objects.

[0032] The terms 'a' or 'an', as used herein, are defined as one or more than one. The term plurality, as used herein, is defined as two or more than two. The term another, as used herein, is defined as at least a second or more. The terms including and/or having, as used herein, are defined as comprising.

- [0033] The term coupled, as used herein, is defined as connected, although not necessarily directly, and not necessarily mechanically.
- [0034] The term 'flexible' or 'elastic' may refer to a material of a part of a shoe that may be stretched and/or compressed and/or folded by exerting a force, and may assume the original shape when the force is removed (elastic) and can be forced to the original shape. The term 'firm' or 'rigid' may refer to a material of a part of a shoe that is not 'flexible' or 'elastic' and may thus retain its shape under the force that stretches and/or compresses the 'flexible' or 'elastic' material or part of the shoe.
- [0035] Reference is now made to Fig. 1, which is a simplified illustration of a side view of an easy-entry footwear 10 with a rear spring 11, according to one embodiment.
- [0036] Footwear, or shoe, 10 of Fig. 1 is a right-shoe adapted for a right foot of a human user (not shown in Fig. 1). A left shoe adapted for a left foot of a human user may be similar to footwear, or a shoe, 10 of Fig. 1.
- [0037] Footwear, or shoe 10 may include a sole 12 and an upper 13. The upper 13 may have a shoe opening 14 for receiving a foot of a user into the shoe 10. The shoe opening 14 may be defined by a rear part 15, a medial part 16, a lateral part 17 and a front part 18. Footwear, or shoe 10 may also include a tongue part 19 and a lacing system 20. Various types of tongue part 19, lacing system 20 and other closure systems are contemplated, including but not limited to closed shoes with elastic or stretchable material, VELCRO or hook and loop type connectors, zippers, snaps, buckles, as well as other types of closure systems.
- [0038] Rear part 15 may include a top part 21, a bottom part 22, and a center part 23 located between top part 21 and bottom part 22. Top part 21 and bottom part 22 may be made of a firm and/or rigid material, that may not bend forward under the force exerted by a foot while it is being entered into the shoe 10 and while pressing down top part 21. Center part 23 may be made from an elastic and/or flexible material that may be compressed under the force exerted by a foot while it is being entered into the shoe 10.
- [0039] Reference is now made to Fig. 2A, which is a simplified illustration of a rear view of the interior of rear part 15 with a circular spring 24, according to one embodiment, and

to Fig. 2B, which is a simplified illustration of a rear view of the interior of rear part 15 with a garter spring 25, according to one embodiment.

[0040] As an option, the illustrations of Fig. 2A and Fig. 2B may be viewed in the context of the details of the previous figures. Of course, however, the illustrations of Fig. 2A and Fig. 2B may be viewed in the context of any desired environment. Further, the aforementioned definitions may equally apply to the description below.

[0041] According to one embodiment, rear spring 11 may be a compression spring mounted between top part 21 and bottom part 22. Alternatively, rear spring 11, or compression spring 11 may be mounted between top part 21 and sole 12. Rear spring 11 may be coupled on one of its ends to top part 21, and to bottom part 22 on its other end. Rear spring 11 may be mounted over (on the outside of) center part 23, or within center part 23. Rear spring 11, or compression spring 11, may be a single spring element of any shape and form and may be made to conform to the shape of rear part 15 of shoe 10. Rear spring 11, or compression spring 11, may be mounted at about the horizontal middle of rear part 15, at the very rear end of shoe 10. Rear spring 11, or compression spring 11, may be the only spring element coupling between top part 21 and bottom part 22 or sole 12.

[0042] When a foot is entered into the shoe 10 and presses down the top part 21, top part 21 may move down with respect to or towards bottom part 22, thus compressing rear spring 11.

[0043] When the foot is fully entered and resting inside the shoe 10, the foot no longer applies downward force on top part 21. As such, rear spring 11 is allowed to push top part 21 back up to its original position.

[0044] It is appreciated that the location of rear spring 11, and the shape of rear spring 11, are adapted to have a minimal effect on the flexibility of opening 14. Thus, the location of rear spring 11, and the shape of rear spring 11, allow opening 14 to adapt to the shape of the particular foot when the foot rests in shoe 10. In this respect, opening 14 may refer to the upper edges of rear part 15, medial part 16, lateral part 17, and front part 18.

- [0045] As shown in Fig. 2A, circular spring 24, which is a rear spring 11 is shaped as a ring, however, other forms of spring 11 are contemplated, such as a horizontal or a vertical ellipse, egg, or an oval form. For example, Fig 2B shows shoe 10 with rear spring 11 in the form of circular garter spring 25. Garter 25 spring may comprise a coiled spring made of carbon steel, stainless steel or any other material, which is connected at each end to create a circular shape.
- [0046] As shown in Figs. 2A and 2B, circular spring 24, and/or garter spring 25, may be coupled by its top portion 26 to top part 21, and by its bottom portion 27 to bottom part 22. Alternatively, circular spring 24 may be coupled by its top portion 26 to top part 21, and by its bottom part 27 to sole 12.
- [0047] Reference is now made to Fig. 3A and Fig. 3B, which are simplified illustrations of a rear view of the interior of rear part 15 of shoe 10 with circular spring 28 where its two edges are not connected, according to one embodiment. Fig. 3A depicts rear part 15 and spring 28 in uncompressed mode, and Fig. 3B depicts rear part 15 and spring 28 in a compressed mode.
- [0048] As an option, the illustrations of Fig. 3A and Fig. 3B may be viewed in the context of the details of the previous Figures. Of course, however, the illustrations of Fig. 3A and Fig. 3B may be viewed in the context of any desired environment. Further, the aforementioned definitions may equally apply to the description below.
- [0049] As shown in Fig. 3A and 3B spring 28 is another example of rear spring 11 and/ or circular spring 24 with a shape of a partial circle, wherein its two edges are not connected. Spring 28 may be coupled by its top portion 26 to top part 21, and by its bottom portion 27 to bottom part 22. Alternatively, spring 28 may be coupled by spring top portion 26 to top part 21, and by its bottom portion 27 to sole 12.
- [0050] As shown in Fig. 3B, top edge 29 of rear part 15 is lower than top edge 29 of rear part 15 in Fig. 3A, thus when top part 21 is depressed it offers more space for a foot to enter the shoe from the rear side of the shoe.
- [0051] Reference is now made to Fig. 4A and Fig. 4B, which are simplified illustrations of a rear view of the interior of rear part 15 of shoe 10 with a sinusoidal compression spring 30, according to one embodiment. Fig. 4A depicts rear part 15 and/or sinusoidal

compression spring 30 in uncompressed mode, and Fig. 4B depicts rear part 15 and/or sinusoidal compression spring 30 in a compressed mode.

- [0052] As an option, the illustrations of Fig. 4A and Fig. 4B may be viewed in the context of the details of the previous Figures. Of course, however, the illustrations of Fig. 4A and Fig. 4B may be viewed in the context of any desired environment. Further, the aforementioned definitions may equally apply to the description below.
- [0053] As shown in Fig. 4A and Fig. 4B, sinusoidal compression spring 30 is a rear spring 11 shaped as with repetitive form of sharp angles, and/or sharp curves. Any alternative repetitive form is also contemplated, such as a sinusoidal form, whether such form is periodic or aperiodic. As shown in Fig. 4A and Fig. 4B, sinusoidal compression spring 30 may be mounted to contract vertically, and may be shaped in a laterally flat form, and may be mounted inside a sleeve (not shown in Figures 4A and 4B), on the interior or exterior surface of the rear part 15 and/or embedded within the rear part 15.
- [0054] As shown in Fig. 4A and Fig. 4B, sinusoidal compression spring 30 may be attached to top part 21 in area 26, and to bottom part 22 in area 27. Spring 30 may be attached to rear part 15 over (on the outside of) center part 23 or within center part 23. Alternatively, sinusoidal compression spring 30 may be attached to top part 21 in area 26 and to sole 12 (not shown in Figs. 4A and 4B).
- [0055] Reference is now made to Fig. 5A, which is a simplified illustration of a side view of shoe 10 with rear part 15 in an uncompressed position, and with an elastic element 31 in an unstretched position, and to Fig. 5B, which is a simplified illustration of a side view of shoe 10 with rear part 15 in a compressed position, and with an elastic element 31 in a stretched position, according to one embodiment.
- [0056] As an option, the illustrations of Fig. 5A and Fig. 5B may be viewed in the context of the details of the previous figures. Of course, however, the illustrations of Fig. 5A and Fig. 5B may be viewed in the context of any desired environment. Further, the aforementioned definitions may equally apply to the description below.
- [0057] As shown in Fig. 5A, at least one part of shoe opening 14, such as, for example, elastic element 31, may be made of elastic material, such as a rubber strap as a non-limiting example. Elastic element 31 is shown in Fig. 5A and Fig. 5B as part of lateral part 17,

however, elastic element 31 may be alternatively mounted as part of medial part 16, or alternatively, as part of both medial part 16 and lateral part 17.

- [0058] When the foot enters the shoe the elastic material of elastic element 31 stretches, thus enabling top portion 21 of rear part 15 to move down, and at the same time, allows shoe opening 14 to expand, providing enough space for the foot to go through the shoe opening. The elastic material may be allowed to contract once the foot enters the shoe, keeping the foot secured inside the shoe.
- [0059] It is appreciated that rear spring 11, as described above or of any other shape and form, may be adapted to the shape of rear part 15. In this respect, rear spring 11 may be curved vertically, upwards and forward, according to the curvature of rear part 15. In this respect, rear spring 11 may be curved horizontally according to the curvature of rear part 15.
- [0060] While the described embodiments have only presented a single rear spring 11 located in the rear part 15 of a shoe, it should be appreciated that in some embodiments, multiple spring elements may be in the rear part 15 and/or the lateral part 17 and/or the medial part 16. Similarly, while some embodiments have been described as utilizing a single elastic element 31 in the lateral part 17 and/or the medial part 16, it should be appreciated that multiple elastic parts 17 may be utilized in the lateral part 17, medial part and/or rear part 15. It should also be appreciated that the elastic part 31 maybe embedded within the interior of the lateral part 17, medial part 16 and/or rear part 15 and a slit or kerf in the lateral part 17, medial part 16 and/or rear part 15 can be forced open by the foot but then drawn back together by the force of the elastic part 31. It should also be appreciated that rather than a separate rear spring 11, the material that the rear part 15, or a portion of the rear part 15 can in and of itself be constructed of an elastic material that can be compress by force but then return to its pre-compressed state upon the removal of the force. For instance, the center part 23 maybe constructed of a material that can be compressed under a force and then rebound to its non-compressed state upon the removal of the force.
- [0061] It is expected that during the life of this patent various footwear technologies and materials will be developed and the scope of the terms herein, particularly of the terms

"footwear", and "shoe", is intended to include all such new technologies and materials a priori.

[0062] Additional objects, advantages, and novel features of the embodiments described herein will become apparent to one ordinarily skilled in the art upon examination of the following examples, which are not intended to be limiting. Additionally, each of the various embodiments and aspects of embodiments as delineated hereinabove and as claimed in the claims section below finds experimental support in the following examples.

[0063] It is appreciated that certain features of the system and method described herein, which are, for clarity, described in the context of separate embodiments, may also be provided in combination in a single embodiment. Conversely, various features, which are, for brevity, described in the context of a single embodiment, may also be provided separately or in any suitable sub-combination.

[0064] Although the system and methods has been described in conjunction with specific embodiments thereof, it is evident that many alternatives, modifications and variations will be apparent to those skilled in the art. Accordingly, it is intended to embrace all such alternatives, modifications and variations that fall within the spirit and broad scope of the appended claims. All publications, patents and patent applications mentioned in this specification are herein incorporated in their entirety by reference into the specification, to the same extent as if each individual publication, patent or patent application was specifically and individually indicated to be incorporated herein by reference. In addition, citation or identification of any reference in this application shall not be construed as an admission that such reference is available as prior art.

CLAIMS

What is claimed is:

1. A shoe comprising a sole and a shoe upper, the shoe upper comprising a shoe opening for entering the shoe, the shoe opening defined by a rear part, a medial part, a lateral part, and a front part,

the rear part comprising:

a top portion, reinforced by a firm material,

a bottom portion, reinforced by a firm material,

a center portion, located between the top portion and the bottom portion, the center portion is made of a flexible material, and

a spring element, wherein its top part is attached to the top portion of the rear part, and its bottom part is attached to the bottom portion of the rear part.

2. A shoe comprising a sole and a shoe upper, the shoe upper comprising a shoe opening for entering the shoe, the shoe opening defined by a rear part, a medial part, a lateral part, and a front part,

the rear part comprising:

a top portion, reinforced by a firm material,

a flexible material, located between the top portion and the sole, and

a compression spring element, wherein its top part is attached to the top portion of the rear part, and its bottom part is attached to the sole.

3. The shoe according to any of claims 1 and 2, wherein the spring element is made of at least one of:

a circular compression spring;

a garter compression spring; and

a sinusoidal compression spring.

4. The shoe according to any of claims 1 and 2, wherein the spring element is at least one of:

mounted at the horizontal middle of the rear part;

curved vertically, upwards, and forward, according to vertical curvature of the rear part; and

curved horizontally according to horizontal curvature of the rear part.

5. The shoe according to any of claims 1, 2, 3, and 4 additionally comprising an elastic element in at least one of: the medial part of the shoe, and the lateral part of the shoe.

6. A method for entering a shoe, comprising the steps of:

providing a shoe comprising a sole and a shoe upper, the shoe upper comprising a shoe opening for entering the shoe, the shoe opening defined by a rear part, a medial part, a lateral part, and a front part, the rear part comprising:

a top portion reinforced by a firm material,

a bottom portion reinforced by a firm material,

a center portion between the top portion and the bottom portion, the center portion made of a flexible material, and

a compression spring element wherein the top part of the compression spring is attached to the top portion of the rear part, and the bottom part of the compression spring element is attached to the bottom portion of the rear part;

exerting a downward force on the top portion of the rear part when a foot enters the shoe to push down the top portion of the rear part, and creating enough space for the foot to enter the shoe; and

releasing the downward force on the top portion of the rear part to enable the compression spring element to push the top portion of the rear part up for securing the foot in the shoe.

7. A method for entering a shoe, comprising the steps of:

providing a shoe comprising a sole and a shoe upper, the shoe upper comprising a shoe opening for entering the shoe, the shoe opening defined by a rear part, a medial part, a lateral part, and a front part, the rear part comprising:

a top portion reinforced by a firm material,

a portion of the rear part between the top portion and the sole made of a flexible material, and

a compression spring element, wherein a top part of the compression spring is attached to the top portion of the rear part, and a bottom part of the compression spring element is attached to the sole of the shoe;

exerting a downward force on the top portion of the rear part when a foot enters the shoe to push down the top portion of the rear part and creating enough space for the foot to enter the shoe; and

releasing the downward force on the top portion of the rear part to enable the compression spring element to push the top portion of the rear part up for securing the foot in the shoe.

8. The method according to any of claims 6 and 7 wherein at least one of the medial part and the lateral part additionally comprises at least one elastic element to allow the shoe opening to expand when the foot enters the shoe.

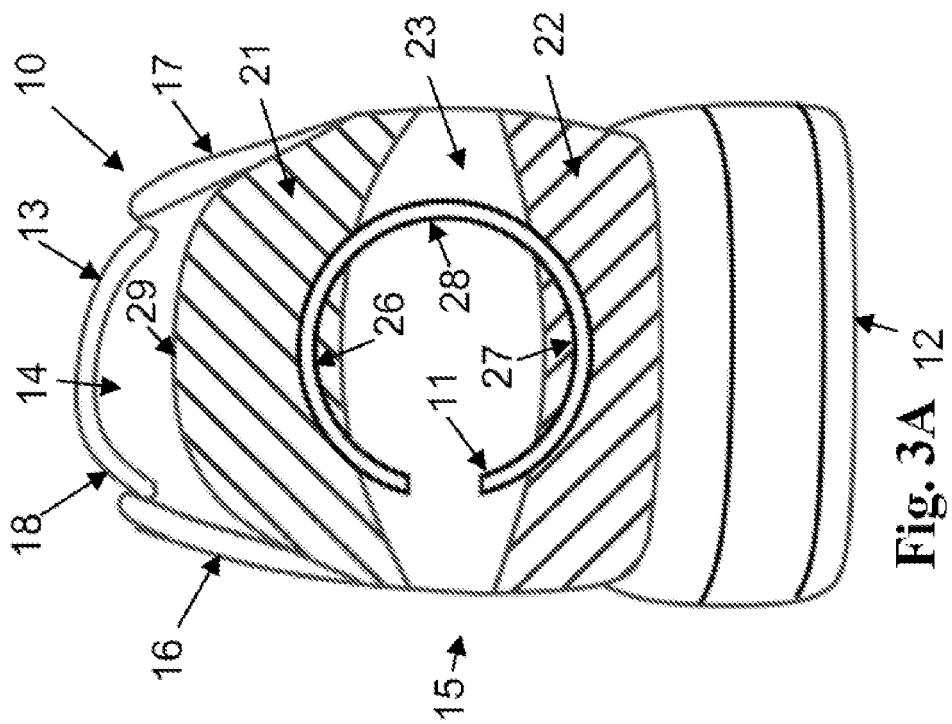
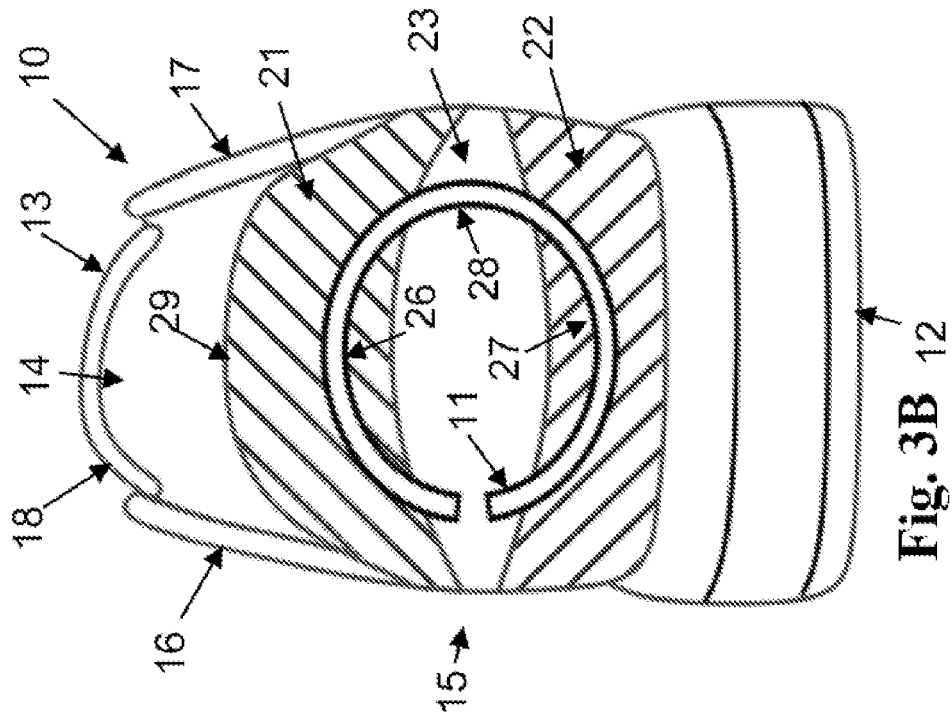

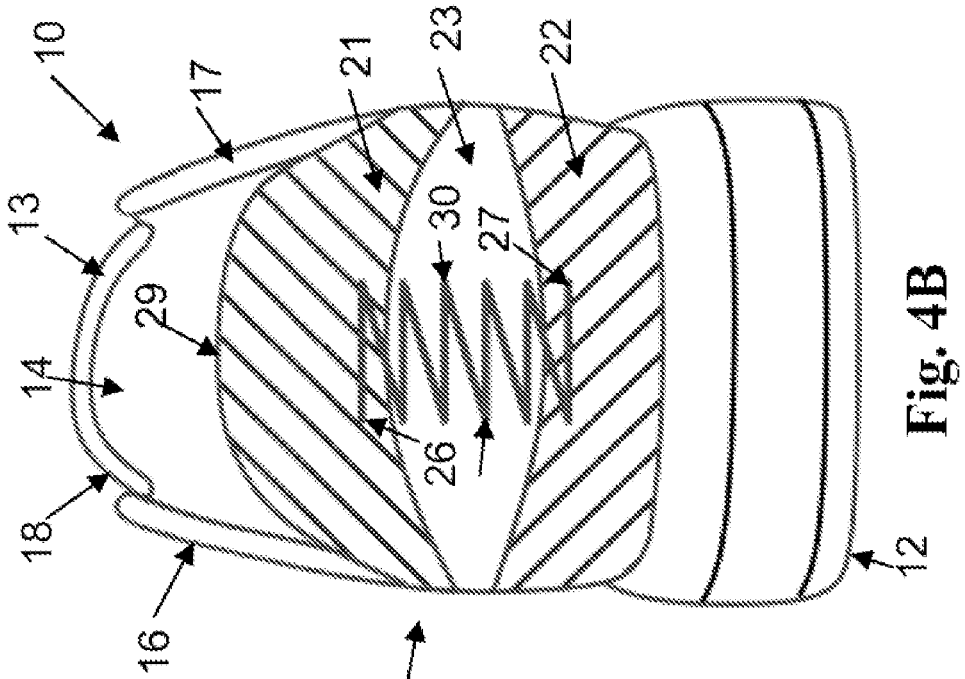

Fig. 4B

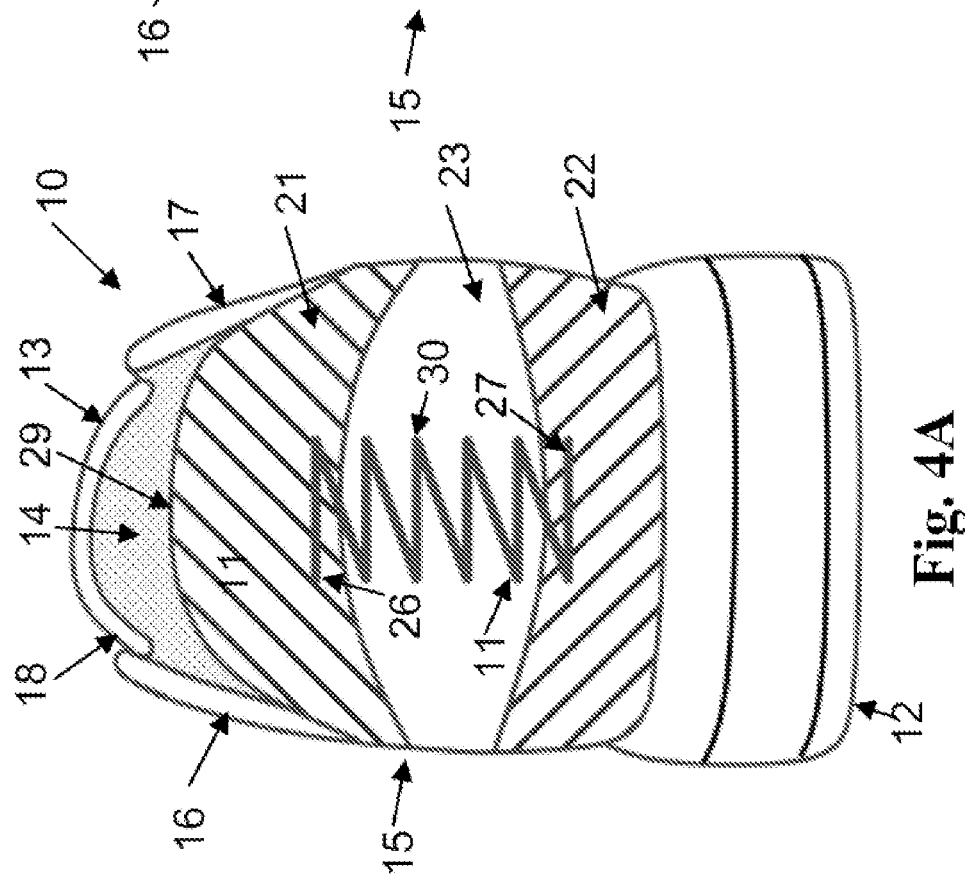

Fig. 4A

