

(No Model.)

R. SMITH.
AGITATOR.

No. 473,530.

Patented Apr. 26, 1892.

Fig. 2.

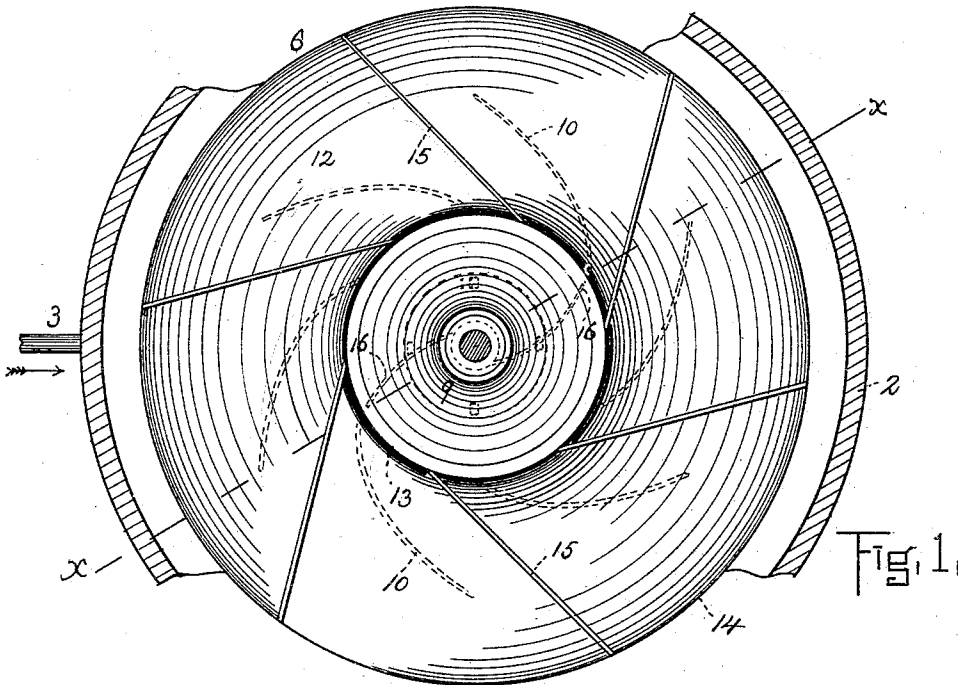
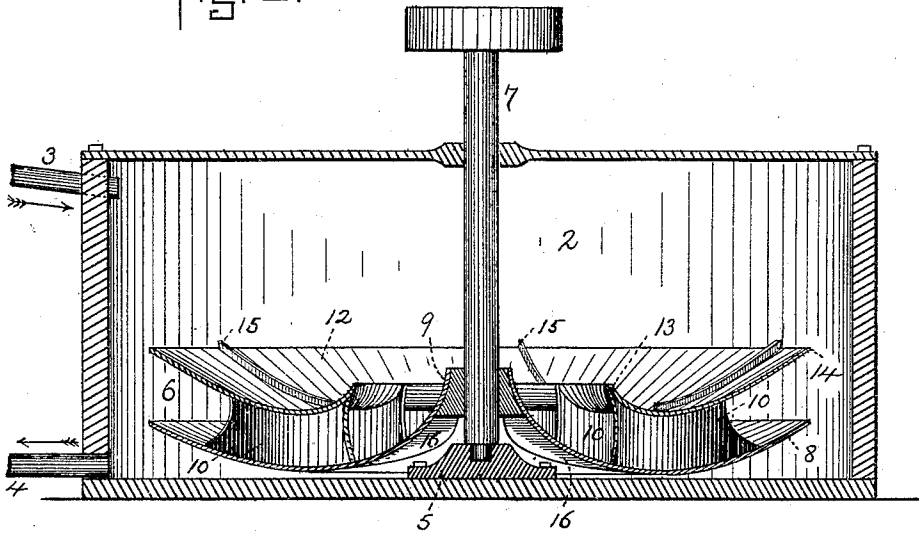

Fig. 1.

Witnesses.

Francis C. Stanwood
John A. Dougherty

Inventor.

Richard Smith,
by H. E. Lodge Atty.

UNITED STATES PATENT OFFICE.

RICHARD SMITH, OF SHERBROOKE, CANADA.

AGITATOR.

SPECIFICATION forming part of Letters Patent No. 473,530, dated April 26, 1892.

Application filed March 25, 1891. Serial No. 386,361. (No model.)

To all whom it may concern:

Be it known that I, RICHARD SMITH, a citizen of the Dominion of Canada, residing at Sherbrooke, in the county of Sherbrooke and Province of Quebec, Canada, have invented certain new and useful Improvements in Agitators; and I do hereby declare the following to be a full, clear, and exact description of the invention, such as will enable others skilled in the art to which it appertains to make and use the same, reference being had to the accompanying drawings, and to the figures of reference marked thereon, which form a part of this specification.

My invention relates to improvements in agitators designed for stirring semi-liquid materials, such as paints, pulp, and analogous substances; and my improvements pertain particularly to the peculiar construction of the agitator, as will hereinafter be described and claimed.

In the accompanying drawings, Figure 1 is a plan view of my improved agitator with the stuff-chest in which it is arranged, partly in horizontal section and partly broken away. Fig. 2 is a vertical section on line *x x*, Fig. 1.

My improvements may be considered as relating to the class of stirring apparatus described in United States Patent No. 423,285, dated March 11, 1890, wherein a series of revolving blades moved beneath a stationary annular plate. In the present instance, however, I propose to have the annular plate revolve in unison with the agitators, for purposes hereinafter explained. The primary features of this stirring apparatus are a central feed and a circumferential discharge.

In the accompanying drawings, 2 represents a circular stuff-chest, in which is contained the material to be subjected to a stirring in order to render the mixture homogeneous.

Supply and discharge pipes are shown at 3 4.

At the bottom and suitably mounted in a step 5 is placed an agitator 6, which is affixed to the foot of a vertical shaft 7, suitably driven from some prime motor. The agitator is composed of an imperforate circular disk 8, slightly dished and with a central upraised cone-shaped center or post 9. This peculiar conformation is to facilitate the circulation, which, as before premised, is a central one

with a circumferential discharge. At right angles to the upper surface of the disk 8 is attached at regular intervals a series of curved arms 10 tangentially disposed. Said arms, however, may be straight in lieu of being curved and equally good results obtained. These arms set upon one edge are of greatest depth near the center and diminish outwardly, as shown in Fig. 2, but terminate a short distance from the outermost part of the disk 8. Surmounting said arms and affixed upon their upper edges is positioned a continuous annular plate 12, which is concave, being oval or semicircular in cross-section, with the inner edge 13 lower than the outer one 14. Furthermore, this plate projects to some extent beyond the outer extremities of the arms and is about of the same diameter as the lower plate or disk 8. Preferably the curvature of said plate is the greatest at the inner edge and becomes less outwardly. By this arrangement it will be seen that the arms 10 and the plate 12 each perform the function of circulating the material in process of mixing—that is, by rapid rotation of the agitator the material operated upon by the arms moves outwardly in vertical planes, while that in contact with and affected by the annular plate 12 moves outwardly in horizontal or slightly-oblique planes. The result is a much-increased circulation, since the amount of material naturally flowing downward and centrally of the agitator is increased in quantity by the centrifugal action created through the agency of the annular plate 12. Preferably a series of ribs 15 may be cast with or secured upon the face of the plate to increase the outward action.

The object in making the arms 10 tapering is to render the inner or receiving end of each space or passage-way existing between two adjacent arms of greater capacity than the discharging ends thereof. This insures the maintenance of a continuous supply of the material operated upon, while the circulation of the said material is increased by the larger mass of material at the center, tending to crowd outwardly through passages which are somewhat contracted by the peculiar formation of the arms 10.

To render the agitator light in construction, the disk 8 is made as a thin casting,

while, owing to the dish-shaped conformation, a space is created between said disk and the step. To prevent material from collecting there and thus not being actuated by the agitator, I have secured two or more blades 5 16 beneath said disk. Hence any material which enters beneath the agitator is subjected to centrifugal action and compelled to circulate and mix with the main body in the 10 vat. Thus by the construction above shown I not only provide or create passages in the agitator, formed by the lower disk, the upper annular plate, and two adjacent arms, but I arrange that all such parts shall move in 15 lieu of having the annular plate stationary. Thus the apparatus is made much more efficient.

What I claim is—

1. The combination, with an imperforate 20 rotary disk and a shaft by which said disk is carried, of an annular concave plate thereabove and a series of interconnecting arms set edgewise and extending obliquely from a point some distance from the center of said 25 disk outwardly, substantially as described.

2. The combination, with a revoluble shaft, of a disk carried thereby and provided with a series of arms tangentially disposed upon the uppersurface thereof and extending from 30 a point some distance from the center of said disk outwardly and an annular concave plate fixed upon and adapted to cover said arms and to revolve with the said disk, the inner edge of said plate being lower than the outer 35 edge thereof, substantially as set forth.

3. The combination, with a rotary driving-shaft suitably mounted, of an agitator thereupon composed of an imperforate circular disk with an upraised center, a series of arms placed edgewise upon the outer portion of the 40 upper surface thereof, and an annular concave plate which surmounts and covers said arms projecting therebeyond and with its outer edge 14 upraised above the inner edge 13, substantially as specified. 45

4. The combination, with an imperforate rotary disk having two or more blades therebeneath and a shaft by which said disk is carried, of an annular concave plate above but non-contiguous and a series of arms interposed edgewise between said disk and plate 50 and extending obliquely outwardly, but terminating at a point some distance from the periphery of said plate and disk, substantially as stated. 55

5. The combination, with a rotary shaft and a disk carried thereby, of an annular plate above said disk and a series of interconnecting arms set edgewise and extending from a point some distance away from the center of 60 said disk outwardly, the said arms being tapered and of greatest depth at their inner extremities, substantially as described.

In testimony whereof I affix my signature in presence of two witnesses.

RICHARD SMITH.

Witnesses:

H. E. LODGE,
FRANCIS C. STANWOOD.