

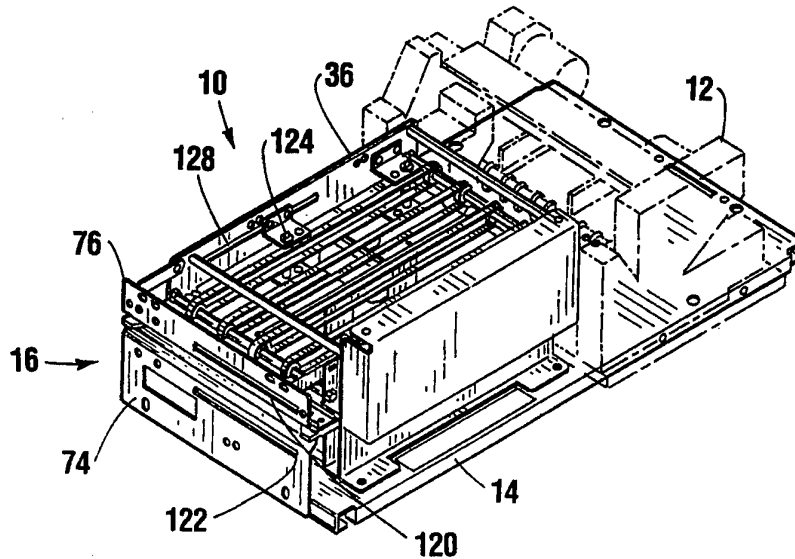

INTERNATIONAL APPLICATION PUBLISHED UNDER THE PATENT COOPERATION TREATY (PCT)

<p>(51) International Patent Classification ⁶ : B65H 9/00</p>	<p>A1</p>	<p>(11) International Publication Number: WO 95/34494 (43) International Publication Date: 21 December 1995 (21.12.95)</p>
<p>(21) International Application Number: PCT/US95/07538 (22) International Filing Date: 2 June 1995 (02.06.95) (30) Priority Data: 08/258,840 10 June 1994 (10.06.94) US (71) Applicant: INTERBOLD [US/US]; 5995 Mayfair Road, North Canton, OH 44720 (US). (72) Inventors: MEYER, Jerry, L.; 7301 Paxton Avenue, N.E., North Canton, OH 44721 (US). WELLBAUM, Wayne, D.; 1087 Marion Avenue, N.W., Massillon, OH 44646 (US). GRAEF, H., Thomas; P.O. Box 287, Bolivar, OH 44612 (US). (74) Agent: JOCKE, Ralph, E.; 231 South Broadway, Medina, OH 44256 (US).</p>	<p>(81) Designated States: AM, AT, AU, BB, BG, BR, BY, CA, CH, CN, CZ, DE, DK, EE, ES, FI, GB, GE, HU, IS, JP, KE, KG, KP, KR, KZ, LK, LR, LT, LU, LV, MD, MG, MN, MW, MX, NO, NZ, PL, PT, RO, RU, SD, SE, SG, SI, SK, TJ, TM, TT, UA, UG, UZ, VN, European patent (AT, BE, CH, DE, DK, ES, FR, GB, GR, IE, IT, LU, MC, NL, PT, SE), OAPI patent (BF, BJ, CF, CG, CI, CM, GA, GN, ML, MR, NE, SN, TD, TG), ARIPO patent (KE, MW, SD, SZ, UG).</p> <p>Published <i>With international search report.</i></p>	

(54) Title: AUTOMATED TELLER MACHINE PASSBOOK TRANSPORT MECHANISM



(57) Abstract

A passbook transport and handling apparatus (10) for transporting a passbook between a customer using an automated banking machine and a printer (12) located inside the banking machine includes first belt flights (32) movable on first pulleys (22). The transport further includes second belt flights (34) movable on second pulleys (28). The second belt flights are disposed transversely intermediate of the first belt flights so that a passbook carried therein between is engaged firmly but with limited slippage. The passbook is guided through the transport by a first fixed edge guide (44). A second edge guide (46) is mounted on a spring (48) so as to bias the passbook into alignment as it passes through the transport. A gate member (72) is movable between positions blocking or admitting a passbook to the transport. Movement of the gate member as well as the belt flights is under control of a processor. Sensors (110, 114, 118 and 124) are operatively connected to and are controlled by the processor and prevent the admission and passage of improperly sized passbooks by the transport.

FOR THE PURPOSES OF INFORMATION ONLY

Codes used to identify States party to the PCT on the front pages of pamphlets publishing international applications under the PCT.

AT	Austria	GB	United Kingdom	MR	Mauritania
AU	Australia	GE	Georgia	MW	Malawi
BB	Barbados	GN	Guinea	NE	Niger
BE	Belgium	GR	Greece	NL	Netherlands
BF	Burkina Faso	HU	Hungary	NO	Norway
BG	Bulgaria	IE	Ireland	NZ	New Zealand
BJ	Benin	IT	Italy	PL	Poland
BR	Brazil	JP	Japan	PT	Portugal
BY	Belarus	KE	Kenya	RO	Romania
CA	Canada	KG	Kyrgystan	RU	Russian Federation
CF	Central African Republic	KP	Democratic People's Republic of Korea	SD	Sudan
CG	Congo	KR	Republic of Korea	SE	Sweden
CH	Switzerland	KZ	Kazakhstan	SI	Slovenia
CI	Côte d'Ivoire	LI	Liechtenstein	SK	Slovakia
CM	Cameroon	LK	Sri Lanka	SN	Senegal
CN	China	LU	Luxembourg	TD	Chad
CS	Czechoslovakia	LV	Latvia	TG	Togo
CZ	Czech Republic	MC	Monaco	TJ	Tajikistan
DE	Germany	MD	Republic of Moldova	TT	Trinidad and Tobago
DK	Denmark	MG	Madagascar	UA	Ukraine
ES	Spain	ML	Mali	US	United States of America
FI	Finland	MN	Mongolia	UZ	Uzbekistan
FR	France			VN	Viet Nam
GA	Gabon				

DESCRIPTION

AUTOMATED TELLER MACHINE PASSBOOK TRANSPORT MECHANISM

TECHNICAL FIELD

This invention relates to automated banking machines. Specifically, this
5 invention relates to a mechanism for handling and transporting a passbook
between a customer operating an automated banking machine and a printer
located inside the machine for printing information in the passbook.

BACKGROUND ART

Automated teller machines (ATMs) are well known in the prior art.
10 Customers use ATMs to conduct a variety of banking transactions. These
transactions may include making deposits to and withdrawals from accounts,
paying bills and checking the status of various accounts.

Some banking transactions have not been performed by ATMs. For
example, many people prefer to have the amount of their savings balance
15 recorded in a passbook. Recording amount information in a passbook has
generally required a human teller to input the transaction data and to align the
passbook in a special printer so that the balance information may be printed in
the proper location.

The automated handling of passbooks has proven to be difficult. This is
20 because passbooks are usually fairly thick and are folded. Passbooks tend to
skew when transported between conventional rollers or belts because a passbook

usually has a different thickness on each side of the fold. This has made it difficult to handle a passbook with automated equipment. Passbooks also come in many different sizes. This has made it difficult to produce a single mechanism that is suitable for handling the wide range of passbooks that may be encountered. It is also difficult to automatically align a passbook with a passbook printer using automated equipment. This is because the passbook pages may tend to become folded and/or caught. Automated handling of passbooks also presents unique problems because of different speeds between the printing mechanism which must firmly engage the passbook during printing and a transport apparatus that may be used to move the passbook. This may result in skewing or misalignment. Such problems result in incorrect positioning of the information which can render the passbook unusable.

Thus there exists a need for a mechanism for handling and transporting a passbook that can be used in an ATM to move a passbook from a customer, position it accurately for printing and then return it to the customer.

DISCLOSURE OF INVENTION

It is an object of the present invention to provide a transport apparatus for a passbook.

It is a further object of the present invention to provide a transport apparatus that can move a passbook between a customer and a printer inside an automated banking machine.

It is a further object of the present invention to provide a transport apparatus for handling and moving a passbook that aligns the passbook as it is moved.

5 It is a further object of the present invention to provide a transport apparatus for a passbook that verifies that the passbook that is presented is properly sized.

It is a further object of the present invention to provide a transport apparatus for a passbook that may be readily adapted to passbooks of various sizes.

10 It is a further object of the present invention to provide a transport apparatus for a passbook that is resistant to vandalism.

It is a further object of the present invention to provide a transport apparatus for a passbook that minimizes the risk of damage to the passbook.

15 It is a further object of the present invention to provide a transport for an item that carries the item in a properly oriented condition.

It is a further object of the present invention to provide a transport apparatus for an item that provides controlled frictional engagement and slippage so the item may be delivered to and from other pieces of equipment moving at different speeds.

20 It is a further object of the present invention to provide a method for transporting a passbook inside an automated teller machine.

It is a further object of the present invention to provide a method for aligning a passbook as it is transported.

Further objects of the present invention will be made apparent in the following Best Modes for Carrying Out Invention and the appended claims.

The foregoing objects are accomplished in the preferred embodiment of the invention by a passbook transport and handling apparatus located inside an automated teller machine. The transport apparatus receives a passbook through an entry slot from a customer who is operating the machine. The interior of the entry slot has a gate member and sensors adjacent thereto interiorally mounted in the machine. The sensors and gate enable only passbooks that are properly positioned and which have a desired width to be admitted to the transport through the entry slot.

The transport includes a plurality of first belt flights which extend parallel to one another and in a longitudinal direction. The longitudinal direction of the belts is the direction in which the passbook is transported into a printer mechanism that is located on an opposed side of the transport from the entry slot. A plurality of second belt flights extend generally parallel to the first belt flights but are positioned in between the first belt flights. The first and second belt flights are supported on first and second pulleys respectively at the ends of the transport and are otherwise unsupported. The first and second belt flights generally extend in a single horizontal plane but may be slightly offset to provide an interwoven effect for holding the passbook between adjacent belt flights.

A pair of spaced edge guides extend in the longitudinal direction inside the transport parallel to the belt flights. The edge guides are positioned for engaging parallel spaced edge surfaces of a passbook. One of the edge guides is mounted in fixed relation to a frame of the apparatus. The other edge guide is

mounted on a spring which operates to bias the passbook toward the fixed edge guide should the passbook become misaligned.

A passbook that enters the transport is admitted in the open, unfolded condition between the belt flights. The first belt flights engage a first planer
5 surface of a passbook and the second belt flights engage the opposed planer surface of the passbook. As the passbook is carried along by the belt flights, any misalignment is corrected by the biasing force of the spring and the edge guides.

The passbook exits the transport apparatus and is delivered to the nip rolls of the printing mechanism. The nip rolls hold the passbook in tightly gripped
10 relation. The belt flights, because they are transversely disposed from one another, provide limited slippage and enable the belts to overrun without damage to the passbook. Once the printing is complete, the passbook is pushed out of the printer and again is moved to a position between the belt flights. The belts begin
15 moving and provide limited slippage until the passbook is free of the printer and may be carried by the belts. The passbook is moved between the belt flights out the entry slot and back to the customer.

The passbook transport and handling apparatus includes sensors that sense the size of the passbook. The transport is operated under the control of a processor so that improperly sized passbooks that are input into the transport
20 apparatus are returned to the customer. A gate member adjacent the entry slot of the transport apparatus also serves to protect the apparatus from acts of vandalism.

The passbook transport and handling apparatus is readily adjustable to accommodate passbooks of different sizes. Further, the transport apparatus of

the present invention may be used for carrying other items such as sheets or stacks of sheets between its entry and exit ends.

BRIEF DESCRIPTION OF DRAWINGS

Figure 1 is a right side isometric view of the passbook transport apparatus
5 with a connected passbook printer mechanism shown in phantom.

Figure 2 is a cross sectional view through the passbook transport apparatus showing a passbook engaged between the belt flights.

Figure 3 is a top plan view of the passbook transport apparatus and an associated printer.

10 Figure 4 is a right side view of the passbook transport apparatus and associated printer.

Figure 5 is a left side isometric view of the passbook transport apparatus.

Figure 6 is a right side isometric view of the transport apparatus.

15 Figure 7 is a partial top view showing the transport apparatus with a passbook positioned therein.

Figure 8 is a partial cross sectional view through the transport apparatus showing the edge guides and sensors of the apparatus.

Figure 9 is an enlarged view of the movable edge guide and sensors of the apparatus.

20 Figure 10 is an exploded isometric view of the apparatus.

Figure 11 is an enlarged view of the exit end of the passbook transport apparatus and the passbook engaging rolls of the printer mechanism.

Figure 12 is a right side cross sectional view of the passbook transport apparatus showing the entry gate member.

Figure 13 is a partial top view of the passbook transport apparatus and gate member.

5 Figure 14 is a partial cross sectional view of the passbook transport apparatus showing the gate member in the closed position with the open position shown in phantom.

 Figure 15 is a partial front cross sectional view of the passbook transport apparatus with the gate member and the actuating mechanism for the gate
10 member shown in the closed position.

 Figure 16 is an enlarged partial front cross sectional view showing the gate member in the closed position.

 Figures 17 through 21 are flow charts of the program executed by the processor which controls operation of the transport apparatus.

15 BEST MODES FOR CARRYING OUT INVENTION

 Referring now to the drawings and particularly to Figure 1, there is shown therein the preferred embodiment of the passbook transport and handling apparatus of the present invention generally indicated 10. The passbook transport apparatus is connected to a passbook printer 12 of a type that is known
20 in the prior art. The passbook transport and printer are preferably positioned inside an automated teller machine which a customer may use to conduct banking transactions.

The transport 10 and printer 12 are mounted on a common base plate 14 which is positioned inside the automated teller machine. The passbook transport includes an entry end 16 which is adapted for receiving and delivering passbooks from a customer operating an automated teller machine through an opening in the
5 facia of the machine. The transport further includes an exit end 18 (see Figure 12) through which the transport mechanism delivers and receives a passbook to the connected printer.

The transport apparatus 10 includes a pair of spaced first shafts 20 (see Figure 3). A plurality of first pulleys 22 are mounted transversely spaced on first
10 shaft 20. A plurality of first belts 24 extend between first pulleys 22. First belts 24 are elastic and first pulleys 22 are crowned pulleys so that the elastic action of the belts maintains them in centered relation on the pulleys.

The transport apparatus 10 further includes a pair of spaced second shafts 26. The second shafts 26 are spaced vertically below the first shafts 20 (see
15 Figure 4). Second shafts 26 have mounted thereon a plurality of spaced second pulleys 28, which are crowned pulleys similar to first pulleys 22. A plurality of second belts 30 extend between second pulleys 28. Second belts 30 are elastic similar to first belts 24 so as to maintain a centered position on second pulleys
28.

20 In the preferred embodiment of the invention the first and second belts are TYPE SFT belts which are available from Belting Industries. The belts are preferably 6 millimeters in width. The crowned first and second pulleys are wider than the belts, and are preferably 8 millimeters in width. By having the crowned pulleys wider than the belts, the possibility of the belts tracking off the

pulleys is reduced. This is because if a belt becomes sufficiently displaced from the center of the pulley and engages the vertical side wall of the pulley, the belt will tend to come off. By having the pulley wider than the belt, greater displacement is required before disengagement will occur. Rotation of the pulley
5 tends to center the belt on the pulley so that a displacement is rapidly corrected. As a result, the belt remains on the pulley under varied service conditions.

As best shown in Figure 2, second pulleys 28 are disposed intermediate of first pulleys 22. Shafts 20 and 26 are positioned such that first belt flights 32, which are the lower flights of first belts 24, and second belt flights 34, which are
10 the upper belt flights of second belts 30, extend in a generally co-planer relationship for reasons that will be later discussed in detail.

As shown in Figure 10, the apparatus includes a pair of first and second upright spaced side walls 36 and 38, respectively. Side walls 36 and 38 each have a lower foot portion that attaches to base plate 14 using conventional
15 fasteners. First and second shafts 20 and 26 are journaled in bearings 40 that are positioned in openings in the side walls. A pair of tie rods 42 extend between the side walls 36 and 38 and hold the side walls in properly spaced relation.

A first edge guide 44 is mounted to first side wall 36 (see Figure 2). A second edge guide 46 is mounted in transversely disposed relation from first edge
20 guide 44 and is positioned between one of the adjacent pairs of first and second belt flights 32 and 34, respectively.

Second edge guide 46 is mounted to a plate spring 48. Plate spring 48 is mounted at its lower side to an angle bracket 50. Angle bracket 50 is mounted to base plate 14 by fasteners that each extend through one of a pair of spaced,

traversely extending slots 52 (see Figure 10). Spaced slots 52 enable second edge guide 46 to be positioned at a selected distance from first edge guide 44. Both first and second edge guides 44 and 46 are generally "C" shaped in cross section and have tapered guide surfaces 54 at each end. The guide surfaces
5 extend outward from each wall of the generally C-shaped edge guides to facilitate the entry of a passbook into the interior of the space bounded by the walls of the edge guide.

First and second belts 24 and 30 are driven by a drive generally indicated 56. As best shown in Figures 5 and 10, drive 56 includes a D.C. electric motor
10 58 which is mounted to wall 36. Motor 58 has a drive shaft that has a pulley 60 mounted thereon. Pulley 60 drives a first drive belt 62 which rotates a double pulley 64 which is mounted for rotation on a pin that extends from wall 36. Double pulley 64 includes an inner pulley surface which is smaller in diameter than the outer pulley surface driven by first drive belt 62. Inner pulley surface
15 drives a second drive belt 66 which in turn drives a pulley mounted on the second shaft 26 at the exit end of the transport. A pair of meshing gears 68 are mounted on the shafts 20 and 26 at the exit end. Drive 56 serves as a speed reducer and enables motor 58 to drive the first and second belts of the transport. Motor 58 is a reversing motor so that it can rotate in either direction and thus
20 move the belts of the transport in either direction and at several speeds.

As best shown in Figure 12, entry end 16 includes an entry slot 70 through which passbooks may be moved. As later discussed in detail, a gate member is movable to selectively block the entry slot or enable a passbook to pass through the entry slot and enter an entrance area, wherein a passbook can

engage the first and second belts. The entry slot 70 is bounded by a lower front panel 74 and an upper front panel 76. The panels are maintained in spaced relation by a pair of spacers 78. The front panels 74 and 76 have transversely elongated slotted openings 80 therein which bound each side of the entry slot.

5 Transparent lenses 82 are positioned in slot 80. Lenses 82 extend in slots 80 to prevent the accumulation of dirt or other material therein. Slotted backing brackets 84 hold the lenses 82 in position. As later discussed in detail, lenses 82 enable infrared sensors to sense the position of a passbook in the entry slot.

As shown in Figure 10, the passbook transport also includes a processor
10 board 86 and an input/output (I/O) board 87. The processor and I/O boards are mounted in a two piece enclosure 88 which is mounted to side wall 38. The processor board 86 includes a processor and a memory and is electrically connected through the I/O board to other components of the passbook transport in a manner later discussed in detail.

15 Gate member 72 is moved between the open and closed positions by an actuating assembly generally indicated 90. The gate actuating assembly 90 includes a rotating solenoid 92 (see Figure 15). The rotating solenoid 92 has an actuator which is connected to a locking cam 94. As shown in Figure 14, the gate member 72 has a generally "S" shape in cross section and includes a lower
20 cam follower portion 96 which is engaged with the locking cam 94 in the closed position of the gate member 72.

The gate member 72 includes an upper folded edge 98. Folded edge 98 engages an inner surface of the upper front panel 76 in the closed position of the gate member. In the open position folded edge 98 provides a guiding surface for

guiding a passbook into and out of the space between the upper and lower front panels. The gate member 72 further includes a vane 100. Vane 100 is sized to be accepted within the slot of a photosensor 102 when the gate member 72 is in open position, which is shown in phantom in Figure 14. In the preferred
5 embodiment of the invention, sensor 102 is a Honeywell Model HOA7720-M22.

As shown in Figure 13, gate member 72 includes a pair of longitudinally extending legs 104. Legs 104 are rotatable on pins 106 which extend from the side walls 36 and 38. Folded edge 98 of member 72 includes cutouts 108. Cutouts 108 are configured to enable member 72 to move downward to the
10 position shown in phantom in Figure 14 and allow the entry slot 70 to be open to the entrance area wherein a passbook can engage the belts. The cutouts 108 are positioned transversely along folded edge 98 so that second pulleys 28 are accepted in the cutouts when the gate member is in the open position.

As best shown in Figure 7, a left edge or first infrared sensor 110 is
15 mounted across the entry slot 70 adjacent to side wall 36. First sensor 110 is of conventional construction and includes an infrared transmitter and receiver. The sensor is in alignment with slotted openings 80 and is enabled to sense through the lenses 82 which extend in the slots. First sensor 110 is adjacent a first edge guide surface 112 of first edge guide 44 (see Figure 8). In the preferred
20 embodiment sensor 110 is spaced inwardly from the first fixed edge guide about 7 millimeters.

A width or second sensor 114 is positioned in traverse alignment with first sensor 110. Second sensor 114 is also an infrared sensor of the conventional construction having a transmitter and receiver that senses by

transmission of light through slots 80 and lenses 82. Second sensor 114 is generally adjacent a second edge guide surface 116 of second edge guide 46, and is spaced about 7 millimeters inwardly therefrom.

5 A wide document or third sensor 118 is disposed slightly further in the traverse direction from second sensor 114. Third sensor 118 also includes a transmitter and receiver that senses through slots 80 and lenses 82. Third sensor 118 is positioned slightly outward from the outer edge of the front guide surface 54 of second edge guide 46 by about 7 millimeters.

10 Second sensor 114 and third sensor 118 are mounted in snap-in fashion to brackets which are held by fasteners in transversely extending sensor mounting slots 120 and 122 which extend in the upper and lower front panels 76 and 74, respectively.

The passbook transport and handling apparatus further includes a length or fourth sensor 124 that is disposed in a longitudinal direction from first sensor 15 110. Fourth sensor 124 includes a transmitter and receiver, each of which is mounted on a bracket 126. Brackets 126 are longitudinally movable in slots 128 in first side wall 36. As later explained, fourth sensor 124 enables the passbook transport of the present invention to be adopted for use with passbooks of various sizes.

20 A document present or fifth sensor 130 is mounted in the passbook transport adjacent to the passbook printer 12. Fifth sensor 130 enables the transport of the present invention to sense the passage of a passbook to and from the printer 12 in a manner later explained.

All of sensors 110, 114, 118, 124 and 130 are preferably infrared sensors. In the preferred embodiment each sensor includes a Model SFH 409-2 emitter and a Model SFH 309-F-3 detector available from the Siemens Company. The detectors preferably include a filter so they are not susceptible to false
5 signals from other light sources.

In operation, a passbook in which printing is to be conducted is presented by the customer to the automated teller machine in which the passbook transport and printer mechanism is mounted. The passbooks with which the present invention is designed to be used are the conventional design which are folded in
10 the closed position. The passbooks are comprised of multiple sheets and/or pages.

Before insertion of the passbook into the transport of the present invention, the passbook is unfolded to the open position. In this position the passbook presents an first upper planer surface 132 and a lower second planer surface 134 (see Figure 2). Further, the passbook has a leading edge 136 which
15 is the edge presented first into the transport and a trailing edge 138 (see Figure 7). The passbook further includes a first side edge surface 140 and a parallel transversely disposed second side edge surface 142. When a customer presents their passbook to the machine, it is extended through the opening in the
20 machine facia and enters the entry slot 70. With no passbook in the transport, the gate member 72 is maintained closed by the engagement of the locking cam 94 with the cam follower surface 96 on the gate member. The I/O board and processor are connected to the sensors and control the motor and gate member. The gate member will not open unless the passbook is positioned so as to block

first sensor 110 and second sensor 114, without also blocking third sensor 118.

These three sensors are positioned to insure that only a passbook having the proper width will be admitted to the transport. If the passbook is positioned and sized to block sensors 110 and 114 but not 118, the rotating solenoid 92 is
5 actuated by a signal from the processor to rotate the locking cam 94 to disengage the gate member 72. When this occurs, the gate member falls to the position shown in phantom in Figure 14. This enables the passbook to move through the entry slot 70 and to an entrance area adjacent the gate wherein it can engage the first and second belts 24 and 30, respectively.

10 Upon opening of the gate member 72, the vane 100 on the gate member moves to be accepted into sensor 102. This provides a signal to the processor board and indicates that the gate is in open position. Upon the sensing of a passbook that is the proper width, (i.e., blocks sensors 110 and 114, but not 118) the processor also operates to generate a signal to start motor 58 which causes
15 belts 24 and 30 to begin moving in a forward direction such that the first belt flights 32 and second belt flights 34 will tend to pull the passbook into the area between the belts. As best shown in Figure 2, the co-planar positions of the first and second belt flights cause the passbook to be "woven" and carried between the belt flights in a manner that holds the passbook while still providing limited
20 slippage. This is very significant as the belt flights are enabled to overrun the movement of the passbook without causing any damage thereto.

As shown in Figure 2, the co-planar position of belt flights 32 and 34 cause the passbook engaging face surface of the lower belt flight to be located above the passbook engaging face surface of the upper belt flight. The offset

between the face surfaces is equal to the thickness of the belts. This works satisfactorily for many passbooks. For transporting thicker or more rigid items, it may be desirable to have the face surfaces at the same level or spaced apart. Likewise, for thinner, more flexible items, it may be desirable to have the face surfaces with a greater offset to increase the "woven" effect. In other

5

embodiments the lateral distance between the belts and the pulleys can be made variable to ideally adjust to the nature of the item carried. This can be done automatically by incorporating a thickness sensor into the device and moving the belts apart according to the thickness sensed. This enables the transport to be

10

tailored to exactly the thickness of the item being carried.

Upon entry of the passbook between the belt flights, the first and second side edge surfaces 140 and 142 of the passbook engage the first and second edge guides 44 and 46, respectively. The tapered guide surfaces 54 at the front and back ends of the edge guides facilitate the passage of the edge surfaces into the

15

interior of the "C" shaped edge guides. The second edge guide 46 on plate spring 48 operates so that if the passbook becomes misaligned, the deflection of spring 48 provides a biasing force that tends to move the passbook back into proper engagement with first edge guide 44. This construction is significant because it enables alignment of the passbook without the application of excessive

20

force which may cause damage thereto. Further, the gentle aligning action of the spring force on the second edge guide enables the gradual correction of any misalignments that may occur during transport of the passbook.

The processor associated with the passbook transport drives the first and second belts to move the passbook into the transport to the position shown in

Figure 7 wherein the leading edge 136 of the passbook is sensed by fourth sensor 124. In this position, sensors 110, 114 and 124 are all in sensing relation with the passbook momentarily. The processor on the processor board 86 is programmed so that if sensor 118 is blocked at any time while the passbook is moving into the transport toward sensor 124, the direction of the motor will be reversed and the passbook will be returned to the customer.

The processor is also programmed so that if sensor 110 becomes unblocked and sensor 124 is not blocked, as would be expected for a properly sized passbook, the processor which serves as means for reversing the direction of the motor, reverses the motor direction. The motor 58 is run in the reverse direction until the passbook is returned out the entry slot 70 to the customer. It is determined that the passbook is back in the entry slot through the signals from sensors 110, 114. This prevents acceptance of a passbook that is the correct width but is "too short."

Alternatively, the processor may be programmed so that if the sensors 110 and 114 should continue to sense the passbook beyond the sensing thereof by sensor 124, the direction of motor 58 may be reversed so as to return the passbook out the entry slot 70 to the customer. This prevents entry of a passbook that is "too long."

If the passbook is the proper size, the gate will close once the passbook has unblocked sensor 110. The passbook will pass through the transport to the exit end 18 wherein it will be sensed by sensor 130. Sensor 130 actuates the passbook printer 12 to prepare to begin operation. The processor also responds to sensor 130 to slow down the motor. The motor slows to move the passbook

at a speed that is slightly slower than the speed at which the printer will move the passbook once it is engaged therewith. As shown in Figure 11, the printer 12 includes a plurality of adjacent nip rolls 144 which hold the passbook firmly therein for purposes of accurately moving the passbook so as to place printing
5 the on the next available line.

As the passbook is moved by the first and second belts 24 and 30 into the nip rolls 144, the processor controls the motor 58 so that the belts overrun until the passbook is securely engaged by the nip rolls. The engagement of the passbook by the printer causes a signal to be generated which is received by the
10 processor. The processor then operates to shut the motor off. The passbook is thereafter moved by the nip rolls of the printer.

As previously discussed, because of the spaced relation of the belts, they are enabled to overrun on the passbook without causing any damage thereto. Likewise, after the printer 12 has printed in the passbook and begins to move it
15 through the nip rolls 144 back between belts 30 and 24, the processor receives a signal from the printer and in response motor 58 is started in the reverse direction to urge the passbook in the reverse direction back towards the entry slot 70. The processor also opens the gate member 72. If the processor fails to receive a signal from sensor 102 that the gate is open, the processor stops the
20 belts. As the printer is returning the passbook to the transport, the belts are operated at a slow speed so as to overrun on the passbook until the nip rolls 144 disengage the passbook. The speed of the belts in this condition is slightly faster than the speed of the passbook coming out of the nip rolls.

Upon disengagement of the nip rolls 144 of the printer, the passbook is carried between the first and second belt flights in the manner shown in Figure 2 back to the entry end 16 of the transport. In an alternative embodiment, if the passbook does not reach the first sensor 110 within a time set by the program
5 which operates in the processor, the motor increases speed. This is effective for freeing a passbook that has become stuck in the transport. Once the passbook reaches sensor 110 the motor shuts off after a time delay which ensures the passbook is extending from the fascia of the machine where a customer may retrieve it.

10 In another alternative embodiment, once the passbook clears the nip rolls of the printer, the sensor 130 sends a signal to the processor. In response the processor causes the motor to increase speed as it carries the passbook out the entry slot to the customer. This can help the transport shorten the return time.

The processor is also operative to execute a computer program in
15 firmware which functions to detect fault conditions and to assure that only properly sized passbooks are admitted to the transport. The processor is also operative to extend the life of the infrared sensors, by shutting off the emitters when the sensors are not in use.

The program executed by the processor of the preferred embodiment of
20 the invention is shown in Figures 17-21. As shown in Figure 17, the transport is made operative through a customer indicating that they intend to present a passbook to the automated teller machine. This is normally done by the customer pushing the appropriate key or other input device on the automated

teller machine. This activates the transport mechanism at a step 146. The processor first operates to turn on the emitters of the infrared sensors.

The processor then "reads" the conditions of the first, second and third sensors 110, 114 and 118 at a step 148. The processor then decides if the passbook being presented is properly positioned and the proper width by blocking sensors 110 and 114, but not 118, at a step 150. If this condition is not satisfied the program returns to step 148. If the passbook appears correctly sized, a second read check of the sensors is made at step 152. A decision is again made at 154 if the passbook is properly sized. A further check to see if the passbook is over width and a check for blocking sensor 118 is made at step 156. If the passbook appears to be the correct width and is properly positioned, the gate member 72 is opened at a step 158.

The sensing of gate member 72 opening based on signals from sensor 102 is checked at step 160. If the gate did not open the sensors are shut off at a step 162 and a fault condition is indicated. If the gate opens properly the processor starts the motor to begin moving the belts at a step 164. As the belts start moving, the processor also begins a timing routine at step 166. The timing routine 166 operates to verify that the passbook properly enters the transport as hereafter explained.

As the passbook moves into the transport, the processor continues to read sensors 110, 114 and 118 at step 168. Sensor 118 is monitored and if it becomes blocked at step 170, which suggests a problem with the size or shape of the passbook, the processor operates to reverse the motor to return the passbook to

the customer at step 172 and to close the gate at step 174. The customer is then free to reinsert the passbook.

If sensor 118 is not blocked as the passbook moves into the transport, the processor waits for sensor 110 to become unblocked at step 176. If the sensor
5 has not unblocked, the processor will see if timing routine 166 has timed out at step 178. If not, the processor returns to step 168. However, if the timer has expired there is a problem. In that case the processor reverses the direction of the motor to return the passbook at step 180 to return the book to the customer. The gate is then closed at step 182 and the sensors shut off at step 184.

10 If sensor 110 unblocks at step 176 before timing routine 166 expires, the processor checks to see if sensor 124 is blocked at step 186. If not, the passbook is "too short" and the steps 188 and 190 are executed to reverse the motor, return the book to the customer and close the gate. If sensor 124 is blocked as sensor 110 becomes unblocked then the passbook is of sufficient
15 length and the processor closes the gate member at step 192.

The closing of the gate commences a timing routine 194. The processor reads sensor 130 at step 196 and looks for it to sense the passbook at step 198. A check is made at step 200 if timing routine 194 has timed out before the passbook is sensed at sensor 130. If so the transport is stopped and shut off at
20 step 202.

If the arrival of the passbook adjacent sensor 130 is sensed within the permitted time, the nip rolls on the printer are started moving at step 204. Thereafter the processor slows the motor to reduce the forward speed of the

passbook at a step 206 to slightly less than the linear speed of the nip rolls of the printer.

As the belts of the transport slow, the processor institutes another timing routine 208. The printer generates signals once the passbook is in its nip rolls.

5 These signals indicate whether the printer has accepted the passbook and it is being held in its nip rolls or whether the printer has rejected the passbook and has failed to accept it into the nip rolls.

At step 210 it is checked whether the printer has sent a signal rejecting the passbook. If not, the processor looks for an acceptance signal from the
10 printer at step 212. If the passbook has been accepted, then everything has worked properly and the processor stops the belts at step 214.

If there has been no rejection of the passbook at step 210, but the printer has not accepted the passbook at step 212, a check is made at step 216 to determine if timing routine 208 has expired. If not, the processor returns to step
15 210. If the time has expired, the processor increases the motor and belt speed at step 218 to rapidly present the passbook to the printer. This speed change may be operative to free a stuck passbook or to overcome resistance to entry into the nip rolls.

If the printer rejects the passbook at step 210, the processor changes the
20 direction of travel of the belts at step 220 until sensor 130 unblocks at step 222. The belts are then stopped at step 224. The processor then checks to see how many times it has previously attempted entry of this passbook to the printer and compares it against a preset number at step 226. If the number of unsuccessful

prior trials equals the preset maximum, the transport shuts off and a fault condition is indicated at step 228.

If the number of trials is less than the set maximum, the processor starts the passbook moving toward the printer again at step 230. A timing routine
5 similar to routine 194 is started at step 232. The number of previous unsuccessful trials is incremented at step 234 and the program returns to step 196. The steps are repeated until the printer either accepts the passbook or until a fault condition occurs.

The portion of the computer program for returning the passbook from the
10 printer to the customer is shown in Figures 20 and 21. The processor waits for a signal from the printer indicating the return of the passbook to the transport at step 236. In response to the signal the processor turns on the motor to run the belts in a reverse direction at step 238. The belts are run in the reverse direction somewhat faster than the linear speed of the nip rolls. The processor opens the
15 gate member at step 240. Opening of the gate member is checked at step 242. If the gate fails to open the transport is shut off and a fault indicated at step 244.

Although in the program shown the belts are run in the reverse direction at a constant speed, in other embodiments the belts are run at a first speed until the passbook disengages the printer as sensed by the printer or by sensor 130.
20 Thereafter the belts are run at a higher speed until the passbook reaches sensor 110.

The opening of the gate member causes initiation of a timing routine 246. The processor then looks to see if sensor 110 senses the passbook adjacent the entry slot at step 248. A check is made at step 250 to see if timing routine 246

has timed out before sensor 110 is blocked. If so there is a problem and the transport shuts down and indicates a fault at step 252.

Alternately, if time 246 has timed out before sensor 110 is blocked by the passbook, the processor increases the motor speed. This speed change often
5 frees a passbook that has become stuck in the transport.

If the passbook reaches sensor 110 before timing routine 246 times out, the processor shuts off the motor at step 254 after a brief time delay, and starts another timing routine 256. The time delay before motor shut off insures that the passbook extends sufficiently from the transport so it can be taken by the
10 customer. The processor then waits for sensor 110 to become unblocked, indicating the customer has taken the passbook at step 258. If the passbook is removed before the timing routine 256 times out, the gate is closed at step 260.

At step 262 the processor checks to see if the routine 256 has timed out. If the timing routine has timed out a counter is incremented at step 264. A
15 check is made to see if the number stored in the counter has reached a preset number (which in the preferred embodiment is 5) at step 266. If not, the processor moves the belts to pull the passbook back into the transport at step 268. If sensor 110 becomes unblocked at step 270 the processor begins moving the belts and the passbook back towards the customer at step 272. A timing
20 routine similar to routine 246 is initiated at step 274 and the program returns to step 248.

After the preset number of unsuccessful attempts to deliver the passbook to the customer at step 266, the processor closes the gate member at step 276. The program delays 15 seconds at step 278. At step 280 the processor again

checks to see if sensor 110 is unblocked. If not the gate is again opened at step 282 and the processor starts moving the passbook into the transport until sensor 110 becomes unblocked at step 284. The transport is then started again to move the passbook back to the customer at step 286. A timing routine similar to
5 routine 246 is initiated at step 288 and the program returns to step 248.

The passbook transport thus continues to try to deliver the passbook back to the customer until the passbook is taken. The repeated movement of the passbook in and out of the entry slot operates to get the customer's attention and helps assure that they will take their passbook.

10 A fundamental advantage of the present invention is its ability to transport a passbook or other article comprised of a single sheet or multiple sheets in a precisely aligned manner while providing limited slippage so as to prevent damage thereto when the passbook is delivered to the printer which moves at a different speed. The transport is also capable of moving items such as passbooks
15 which have covers, which gives each surfae a different coefficient of friction.

A further advantage of the present invention is that the transport may be readily modified to accept passbooks of different widths. This is accomplished by changing the position of the second edge guide 46 which may be moved by changing the position of angle bracket 50 in the slots 52 of the base plate 14. In
20 addition, the positions of the second, third and fourth sensors may be readily modified to accommodate the length and width of any passbook with which the transport is desired to be used. Such modification may be readily accomplished and enables the passbook transport of the present invention to be used with a variety of passbooks.

A further advantage of the invention is that unlike other transports, there is no compression of the belts while idle, which can cause undesirable rubber compression, flat spots and belt creep. Scuffing of belts caused by speed differentials is also avoided. Such problems are common in transports which use
5 abutting belts.

The "waffle" effect on items moved in the transport of the present invention causes stiffening of the item transported. This makes it easier to move the transported item through joints or gaps which may extend between the transport and other devices.

10 Another fundamental advantage of the invention is that skewing is avoided. In prior transports which have opposed rollers or belts, items that have non-uniform thickness in a direction perpendicular to travel will tend to skew. This is because the greater thickness results in a pinching action and more drive force applied in the thicker area. Because the transport of the present invention
15 is not so affected by articles of varying thickness, transport in an aligned direction is accomplished without skewing.

Although the preferred embodiment of the invention is used as a passbook transport, other types of materials or objects may be transported using the invention. This may particularly include stacked articles such as sheets.

20 Thus, the passbook transport and handling apparatus for a banking machine of the present invention achieves the above-stated objectives, eliminates difficulties encountered in the use of prior devices and systems, solves problems and attains the desirable results described herein.

In the foregoing description, certain terms have been used for brevity, clarity and understanding. However, no unnecessary limitations are to be implied therefrom because such terms are for descriptive purposes and are intended to be broadly construed. Moreover, the descriptions and illustrations
5 given are by way of examples and the invention is not limited to the exact details shown and described.

Having described the features, discoveries and principles of the invention, the manner in which it is constructed and operated and the advantages and useful results attained; the new and useful structures, devices, elements, arrangements,
10 parts, combinations, systems, equipment, operations and relationships are set forth in the appended claims.

CLAIMS

We claim:

1. A passbook transport apparatus for moving a passbook between a
5 customer and a printer in a banking machine, said passbook having a first
generally planar surface and an opposed second generally planar surface, and a
pair of opposed generally parallel first and second side edge surfaces, said
apparatus comprising:

a plurality of first movable belt flights, said belt flights extending
10 in a longitudinal direction, said first flights engagable with said first planar
surface of said passbook;

at least one second movable belt flight, said second belt flight
extending in the longitudinal direction, said second belt flight engagable with said
second planar surface of said passbook when said first flight is engaged with said
15 first planar surface;

a first edge guide extending in a longitudinal direction, said first
edge guide engagable with a first side edge surface of said passbook;

a second edge guide extending in a longitudinal direction, said second edge guide engagable with said second side edge surface of said passbook when said first edge guide is engaged with said first edge surface;

a spring biasing the second edge guide toward the first edge guide,
5 whereby when said passbook is between said edge guides said first and second side edge surfaces are maintained in alignment with said edge guides; and

a drive for moving said first and second belt flights, whereby said passbook is carried between said first and second belt flights.

2. The apparatus according to claim 1 wherein said second belt flight is
10 disposed transversely intermediate of said first belt flights.

3. A passbook transport apparatus for moving a passbook between a person and a printer in a banking machine, said passbook having a first generally planar surface and an opposed second generally planar surface, and a pair of opposed generally parallel first and second side edge surfaces, said apparatus
15 comprising:

a plurality of first movable belt flights, said belt flights extending in a longitudinal direction, said first flights engageable with said first planar surface of said passbook;

at least one second movable belt flight, said second belt flight extending in the longitudinal direction, said second belt flight engageable with said second planar surface of said passbook when said first flight is engaged with said first planar surface;

5 a first edge guide extending in a longitudinal direction, said first edge guide engageable with a first side edge surface of said passbook;

a second edge guide extending in a longitudinal direction, said second edge guide engageable with said second side edge surface of said passbook when said first edge guide is engaged with said first edge surface;

10 a generally planar plate spring biasing the second edge guide toward the first edge guide, and wherein said plate spring extends generally perpendicular to said first and second planar surfaces of said passbook, whereby when said passbook is between said edge guides said first and second side edge surfaces are maintained in alignment with said edge guides; and

15 a drive moving said first and second belt flights, whereby said passbook is carried between said first and second belt flights.

4. The apparatus according to claim 3 wherein said second edge guide extends at a free end of said plate spring.

5. The apparatus according to claim 4 wherein said second edge guide is generally C-shaped in cross section.

6. The apparatus according to claim 5 wherein said second edge guide includes tapered guide surfaces at a front end thereof whereby said passbook is
5 guided into the edge guide.

7. The apparatus according to claim 6 wherein said second edge guide includes tapered guide surfaces at a back end thereof said back end positioned longitudinally opposite of said front end.

8. The apparatus according to claim 7 wherein said first edge guide is a
10 mirror image of said second edge guide.

9. The apparatus according to claim 1 wherein said apparatus comprises means for selectively positioning said second edge guide whereby said apparatus is enabled to transport passbooks of differing dimensions.

10. The apparatus according to claim 2 wherein said first and second belt
15 flights are generally co-planar.

11. The apparatus according to claim 2 wherein said apparatus has an entry end, and wherein said passbook is delivered by said customer into said entry end, and wherein said first and second belt flights are journaled on first

and second pulleys respectively, and wherein at said entry end of said apparatus said pulleys are aligned in a direction traverse of said longitudinal direction.

12. The apparatus according to claim 11 wherein said first and second pulleys are crowned pulleys and wherein said belts are comprised of elastic material, whereby said belts are self-centering on said pulleys.

13. The apparatus according to claim 12 wherein said pulleys have a pulley width greater than a belt width of said belts.

14. The apparatus according to claim 1 wherein said apparatus includes a plurality of second belt flights, said second belt flights positioned transversely intermediate of said first belt flights.

15. The apparatus according to claim 14 wherein said apparatus comprises first belts each journaled on first pulleys, said first pulleys mounted coaxially on a pair of first spaced shafts, said first belts including said first belt flights, said apparatus further comprising second belts each journaled on second pulleys, said second pulleys mounted coaxially on a pair of second spaced shafts, said second belts including said second belt flights, and wherein said first and second belt flights are generally co-planar.

16. The apparatus according to claim 15 wherein said first and second shafts are adjacent, and wherein said first and second belts are elastic, and wherein said first and second pulleys are crowned pulleys.

17. The apparatus according to claim 1 and further comprising a movable
5 gate member for selectively blocking access to said first and second belt flights.

18. The apparatus according to claim 17 wherein said gate member comprises a cam follower portion, said apparatus further comprising a locking cam and means for moving said locking cam wherein said cam enables movement of said gate member between a first position wherein said gate
10 member blocks access to said belts by a passbook and a second position wherein said gate member enables said passbook to enter between said belts.

19. The apparatus according to claim 18 wherein said apparatus includes a frame and wherein said gate member includes a pair of legs and wherein said legs are pivotally mounted on said frame.

15 20. The apparatus according to claim 18 wherein said cam follower portion of said gate member is generally U-shaped in cross section.

21. The apparatus according to claim 20 wherein said gate member further comprises in cross section a folded edge portion at an opposed end from said cam follower portion, whereby said folded edge serves as a guide.

22. The apparatus according to claim 21 wherein said folded edge portion includes at least one cutout and wherein at least one of said second belt flights are enabled to pass through said cutout in the second position of said gate member.

5 23. A passbook transport apparatus for moving a passbook between a person and a printer in a banking machine, said passbook having a first generally planar surface and an opposed second generally planar surface, and a pair of opposed generally parallel first and second side edge surfaces, said apparatus comprising:

10 a plurality of first movable belt flights, said belt flights extending in a longitudinal direction, said first flights engageable with said first planar surface of said passbook;

 at least one second movable belt flight, said second belt flight extending in the longitudinal direction, said second flight engageable with said
15 second planar surface of said passbook when said first flight is engaged with said first planar surface;

 an entrance area for admitting said passbook between said first and second belt flights;

 a first sensor adjacent said entrance area;

a second sensor adjacent said entrance area and spaced transversely of said first sensor;

a drive moving said first and second belt flights, whereby said passbook is carried between said first and second belt flights;

5 wherein said first and second sensors are in operative connection with said drive wherein said drive is operable to move said belt flights in a first longitudinal direction to accept said passbook between said first and second belt flights upon sensing of said passbook by said first and second sensors.

10 24. The apparatus according to claim 23 and further comprising a third sensor transversely spaced further from said first sensor than said second sensor, said third sensor in operative connection with said drive wherein when said passbook is sensed by said first, second and third sensors said drive is inoperative.

15 25. The apparatus according to claim 23 and further comprising a first edge guide extending in the longitudinal direction, said first edge guide engagable with the first side edge surface of said passbook, and a second edge guide extending a said longitudinal direction, said second edge guide engageable with said second side edge surface of said passbook when said first edge guide is engages with said first edge surface, and wherein said first sensor is generally

aligned with in the longitudinal direction with said first edge guide and said second sensor is generally longitudinally aligned with said second edge guide.

26. The apparatus according to claim 23 and further comprising a fourth sensor disposed in the longitudinal direction from said first sensor, said fourth
5 sensor in operative connection with said drive, and wherein said drive is operable to stop movement of said first and second belt flights in the first longitudinal direction unless said passbook is sensed by said fourth sensor upon ceasing to be sensed by said first sensor or said second sensor.

27. The apparatus according to claim 26 wherein one of said first sensor
10 or said second sensor is further operatively connected to a timing device wherein said drive stops moving said first and second belt flights in the first direction if said one of said first sensor or said second sensor does not cease sensing said passbook a time after said fourth sensor senses said passbook.

28. The apparatus according to claim 26 and further comprising a means
15 for moving said first and second belt flights in an opposed longitudinal direction after stopping movement of said belt flights in the first direction.

29. The apparatus according to claim 27 and further comprising means for moving said first and second belt flights in an opposed longitudinal direction after stopping movement of said belt flights in the first direction.

30. A passbook transport apparatus for moving a passbook between a person and a printer in a banking machine, said passbook having a first generally planar surface and an opposed second generally planar surface, and a pair of opposed generally parallel first and second side edge surfaces, said apparatus
5 comprising:

a plurality of first movable belt flights, said belt flights extending in a longitudinal direction, said first flights engagable with said first planar surface of said passbook;

at least one second movable belt flight, said second belt flight
10 extending in the longitudinal direction, said second flight engagable with said second planar surface of said passbook when said first flight is engaged with said first planar surface;

an entrance area for admitting said passbook between said first and
second belt flights;

15 a movable gate member selectively blocking said entrance area;

a first edge guide extending in a longitudinal direction, said first edge guide engagable with a first side edge surface of said passbook;

a second edge guide extending in a longitudinal direction, said second edge guide engagable with said second side edge surface of said passbook when said first edge guide is engaged with said first edge surface;

5 a drive moving said first and second belt flights, whereby said passbook is carried between said first and second belt flights;

a first sensor adjacent said entrance area;

a second sensor adjacent said entrance area; said second sensor spaced transversely of said first sensor; and

10 wherein said first and second sensors are operatively connected with said gate member and wherein said gate member opens said entrance area upon sensing of said passbook adjacent said first and second sensors.

15 31. The apparatus according to claim 30 wherein said first sensor is generally aligned in the longitudinal direction with said first edge guide and said second sensor is generally aligned in the longitudinal direction with said second edge guide.

32. The apparatus according to claim 30 wherein said apparatus further comprises a third sensor adjacent said entrance area, said third sensor transversely spaced further from said first sensor than said second sensor, and wherein said

third sensor is operatively connected to said gate member and wherein when said passbook is sensed by said first, second and third sensors said gate member is in blocking relation of said entrance.

33. The apparatus according to claim 30 and further comprising a fourth
5 sensor spaced in the longitudinal direction from said first sensor, said fourth sensor in operative connection with said gate member and said drive, and further comprising means for closing said gate member when the passbook is sensed adjacent to said fourth sensor and disposed from said first sensor when said belt
10 flights are moving in a first longitudinal direction.

34. The apparatus according to claim 33 and further comprising means
10 for sensing said gate member in the open position and means for stopping movement of said passbook in an opposed longitudinal direction if said gate member is not sensed in the open condition.

35. The apparatus according to claim 34 wherein said sensing means
15 comprises a vane extending from said gate member.

36. A transport apparatus for moving an item from an entry end to an
exit end of said transport comprising:

a plurality of first movable belt flights extending parallel and in a longitudinal direction, each said first belt flight supported on first supporting members at longitudinally spaced intervals;

5 at least one second movable belt flight extending in the longitudinal direction, said second belt flight positioned transversely intermediate of said first belt flights and generally co-planar therewith, second belt flights supported on second supporting members at longitudinally spaced intervals; and

a drive moving said belt flights in a first longitudinal direction wherein an item is carried between said first and second belt flights;

10 a first edge guide extending in the longitudinal direction and wherein said first edge guide is engagable with a first side surface of the item as said item moves through said transport;

15 a second edge guide extending in the longitudinal direction and disposed from said first edge guide a distance in a transverse direction, and wherein said second edge guide is engagable with a second side surface of said item as said items moves through said transport; and

an adjusting mechanism selectively modifying the distance in said transverse direction between said first and second edge guides, whereby said transport is enabled to transport items having different transverse dimensions.

37. The apparatus according to claim 36 wherein said apparatus comprises a plurality of second belt flights.

38. The apparatus according to claim 36 wherein said item comprises spaced parallel side edge surfaces

5 39. The apparatus according to claim 38 and further comprising a spring biasing at least one of said edge guides toward said other of said edge guides.

40. The apparatus according to claim 39 wherein at least one of said first and second edge guides are generally "C"-shaped in cross section.

10 41. The apparatus according to claim 36 wherein said first and second belt flights are comprised of elastic material, and wherein said first and second supporting members include crowned rollers, and wherein said belt flights are movable in engagement with said rollers, whereby said belt flights are self-centering thereon.

15 42. The apparatus according to claim 36 wherein said first belt flights have a first item engaging face surface facing in a first face direction, and wherein said second belt flights have a second item engaging face surface facing in an opposed face direction, and wherein said first item engaging surface is disposed in the first face direction from said second item engaging surface.

43. The apparatus according to claim 42 wherein said item is a passbook.

44. A method for transporting an item having generally parallel side edge surfaces in an automated banking machine, comprising the steps of:

supporting said item between a plurality of first belt flights
5 extending parallel and in a longitudinal direction, said first belt flights supported
on first supporting members at longitudinally spaced intervals, and a plurality of
second belt flights extending in said longitudinal direction and transversely
intermediate of said first belt flights, said second belt flights supported on second
supporting members at longitudinally spaced intervals, said first and second belt
10 flights being generally co-planar;

providing a gate member for selectively blocking an items from
entering between said belt flights;

sensing with first sensors when the width of said item between said
edge surfaces generally corresponds to a distance between first and second
15 longitudinally extending edge guides; and

opening said gate member in response to said sensing means
sensing said distance between said edge surfaces;

moving said first and second belt flights in a first longitudinal direction; and

engaging said item between said first and second belt flights wherein said item is carried between said belt flights with a first side edge surface in engagement with said first edge guide and said opposed side edge surface in engagement with said second edge guide.

45. The method according to claim 44 and further comprising the step of biasing with a spring at least one of said edge guides towards said other of said edge guides.

10 46. The method according to claim 44 and further comprising the steps of:

moving said belt flights in a first direction to accept said item thereinbetween;

sensing with a second sensor disposed longitudinally from said first sensor a length of said item; and

15 moving said belt flights in an opposed direction when said length is below a value.

47. The method according to claim 44 and further comprising the steps
of:

moving said belt flights in a first direction to accept an item
thereinbetween;

5 sensing with a second sensor disposed longitudinally from
said first sensor a length of said item; and

moving said belt flights in an opposed direction when said
length is in excess of a value.

48. A passbook transport apparatus for moving a passbook between a
10 person and a printer in a banking machine, said passbook being deformable and
having a first generally planar surface, and a second generally planar surface,
and a pair of opposed generally parallel first and second side edge surfaces, said
apparatus comprising:

a plurality of first pulleys disposed from one another in a
15 transverse direction;

a plurality of first belt flights supported on said first pulleys, said
first belt flights extending in a longitudinal direction, said first flights extending
generally coplanar and engageable with said first planar surface of said passbook;

at least one second pulley transversely disposed between an adjacent pair of said first pulleys and disposed away from each of said first pulleys in said transverse direction;

5 a second belt flight supported on said second pulley and extending in said longitudinal direction, said second belt flight generally co-planar with said first belt flights, said second belt flight engagable with said second planar surface of said passbook when said first belt flight is engaged with said first planar surface;

10 a drive moving said first and second belt flights in the longitudinal direction and wherein said passbook is movable on said belt flights between said pulleys with said side edge surfaces extending generally in the longitudinal direction, wherein said passbook deforms when adjacent said pulleys to enable passage therethrough.

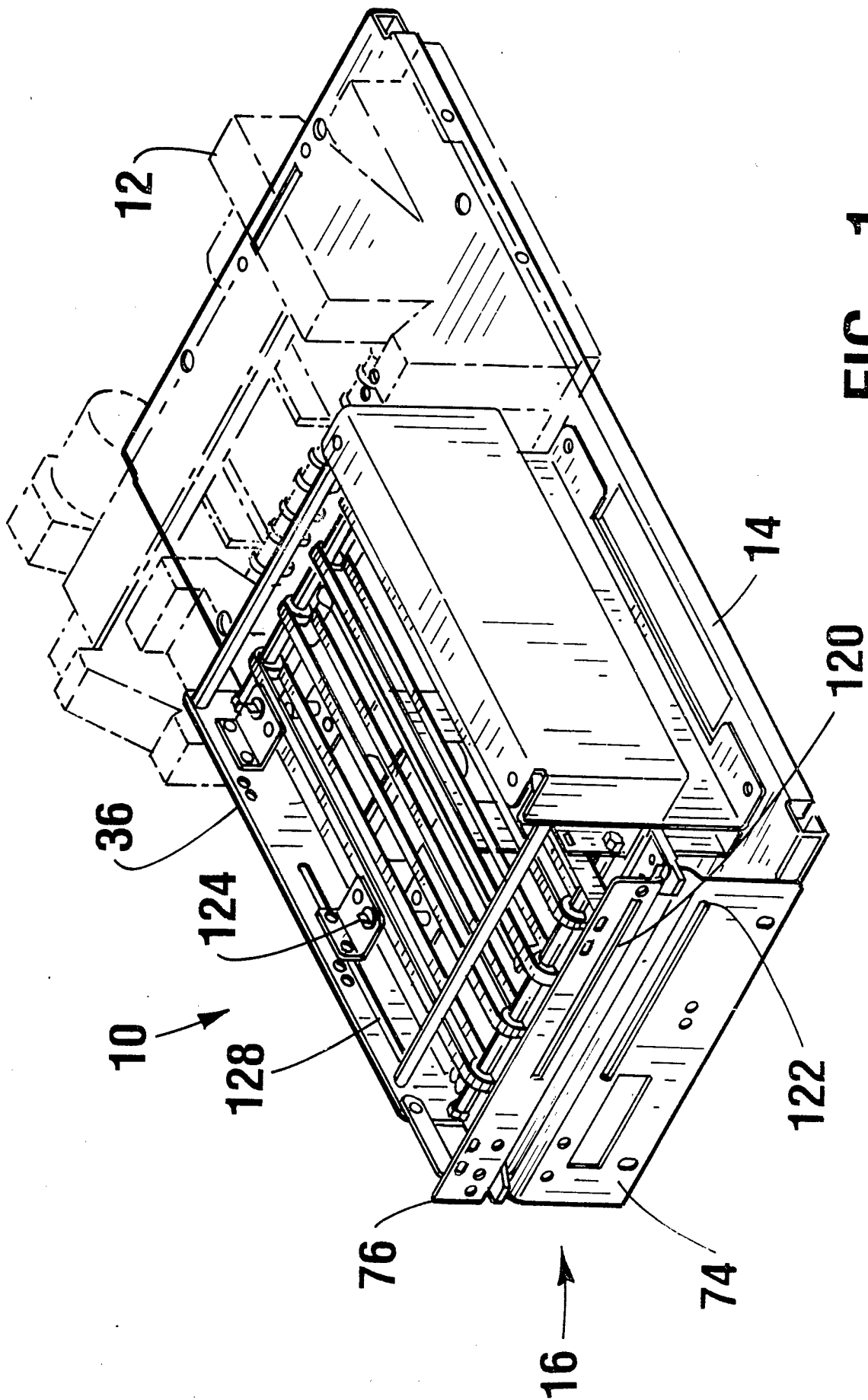

FIG. 1

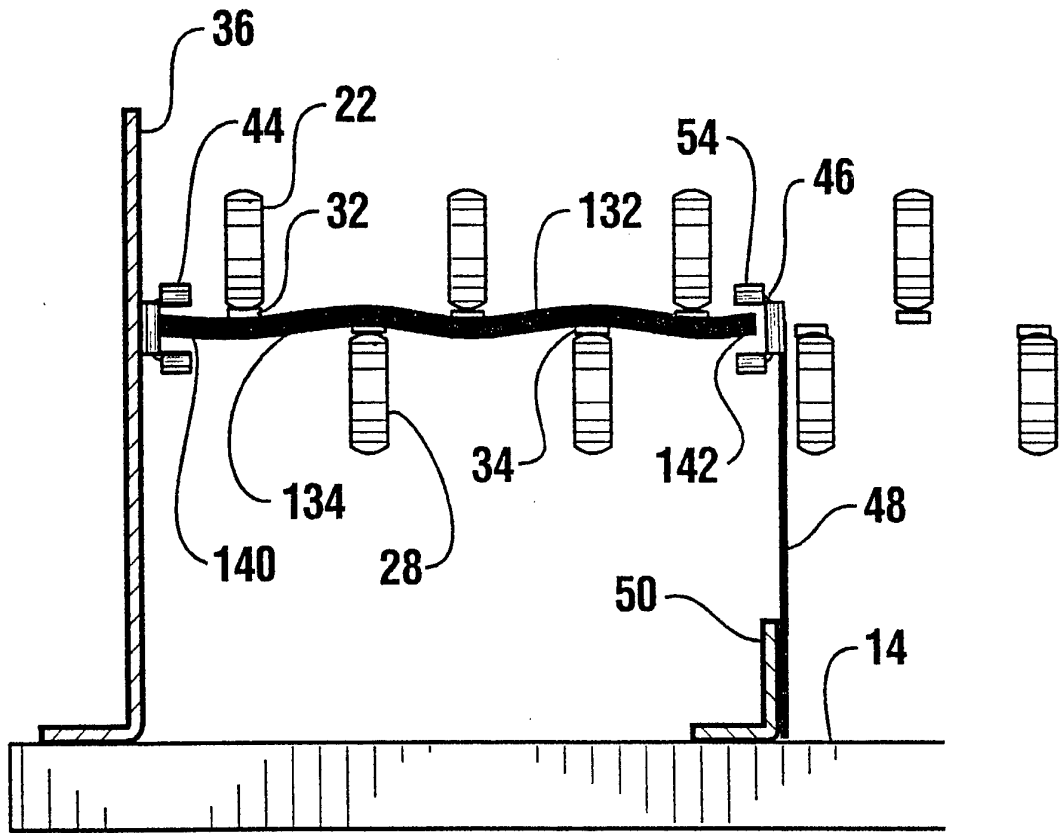
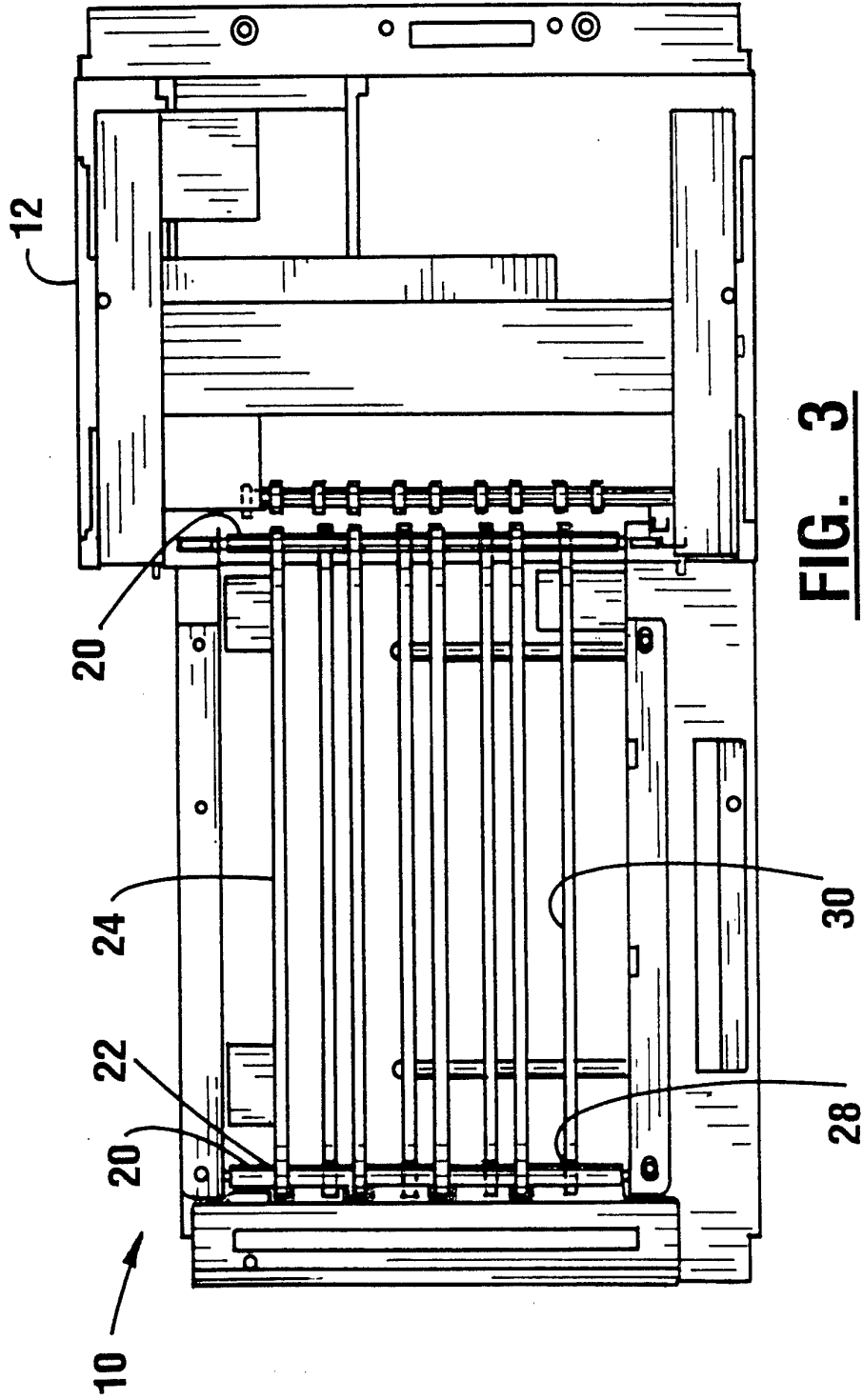

FIG. 2



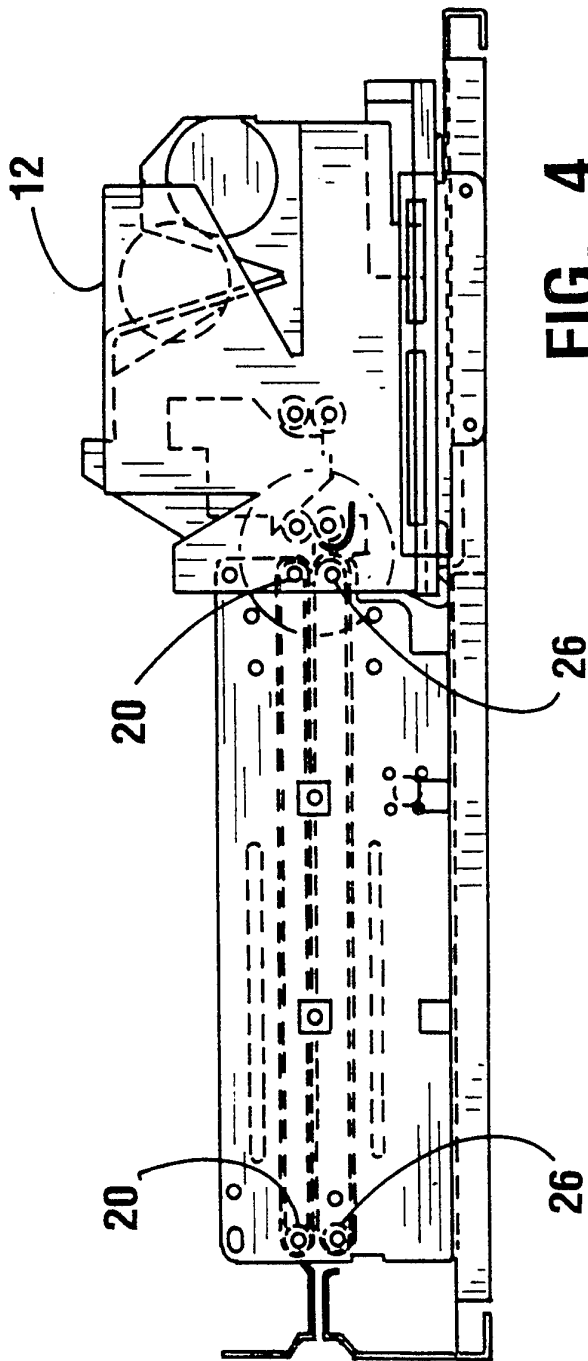

FIG. 4

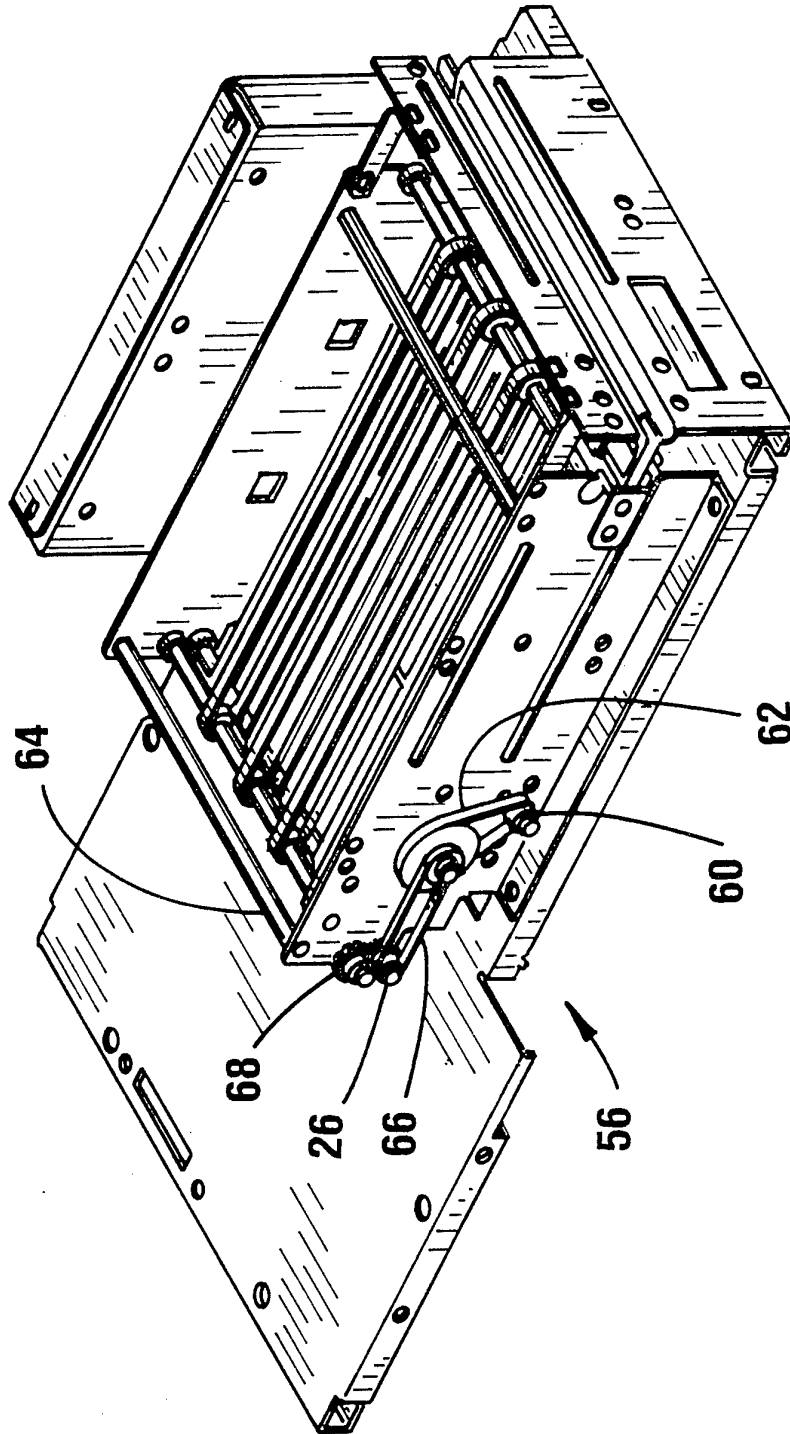

FIG. 5

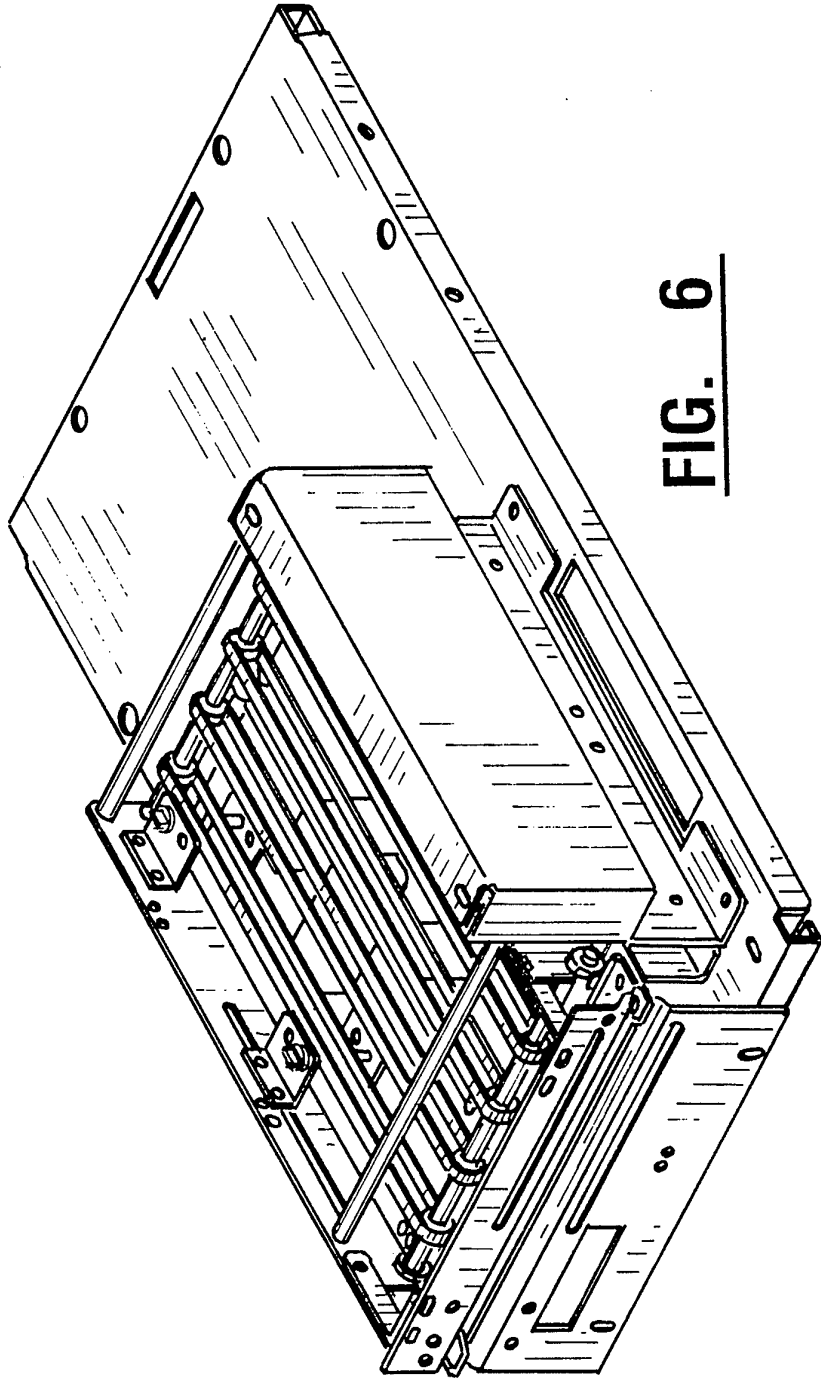

FIG. 6

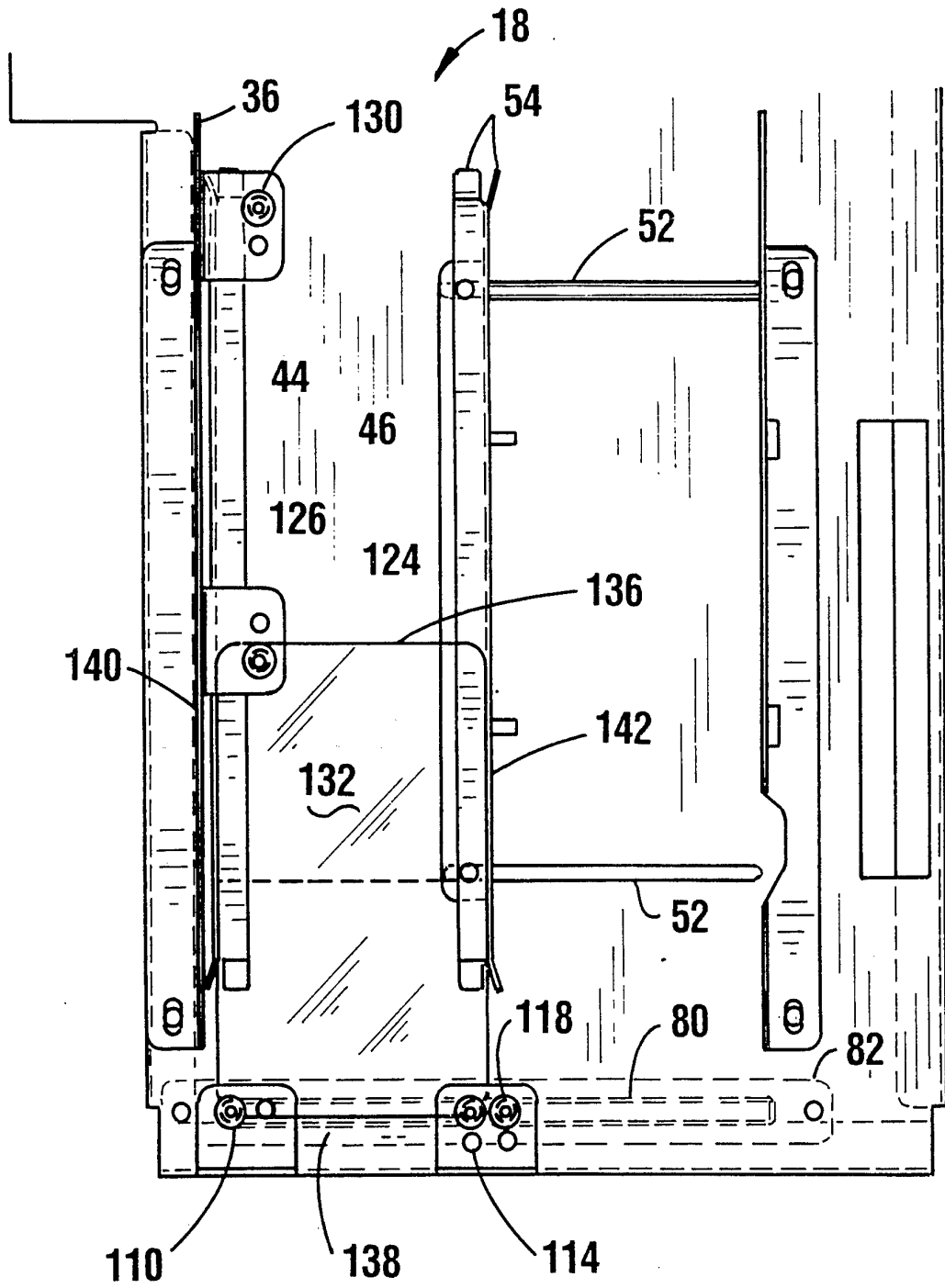

FIG. 7

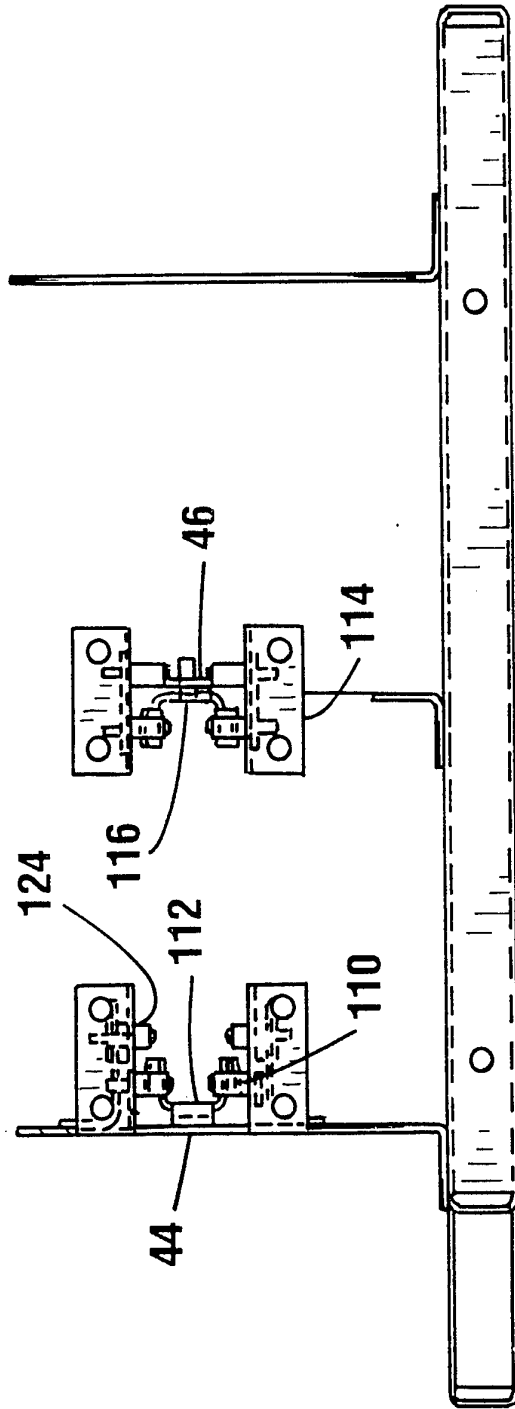

FIG. 8

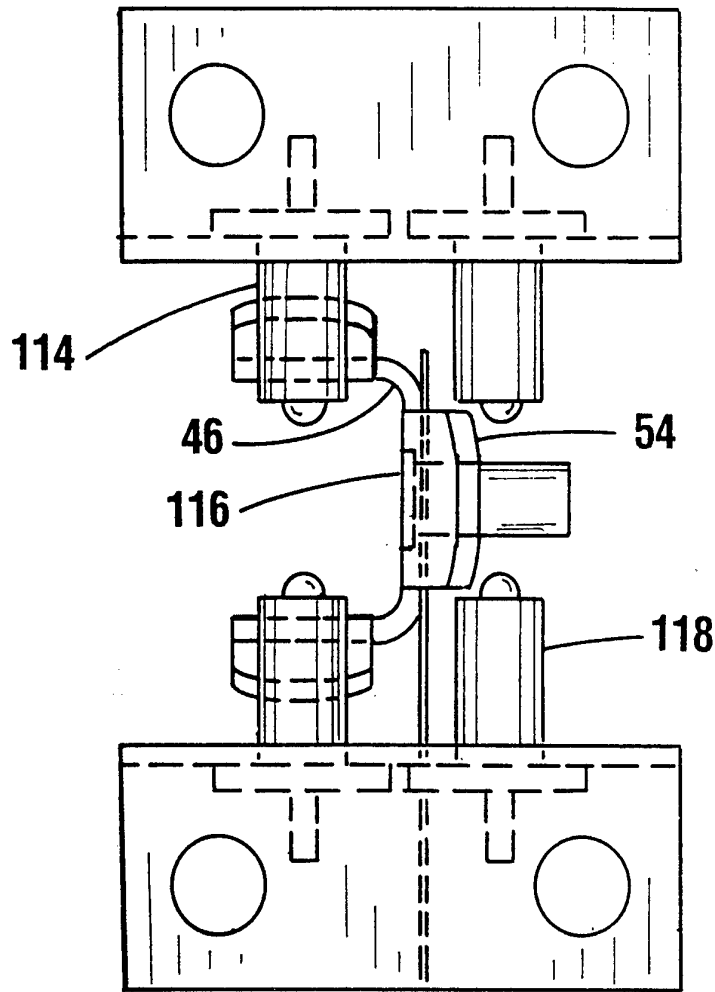

FIG. 9

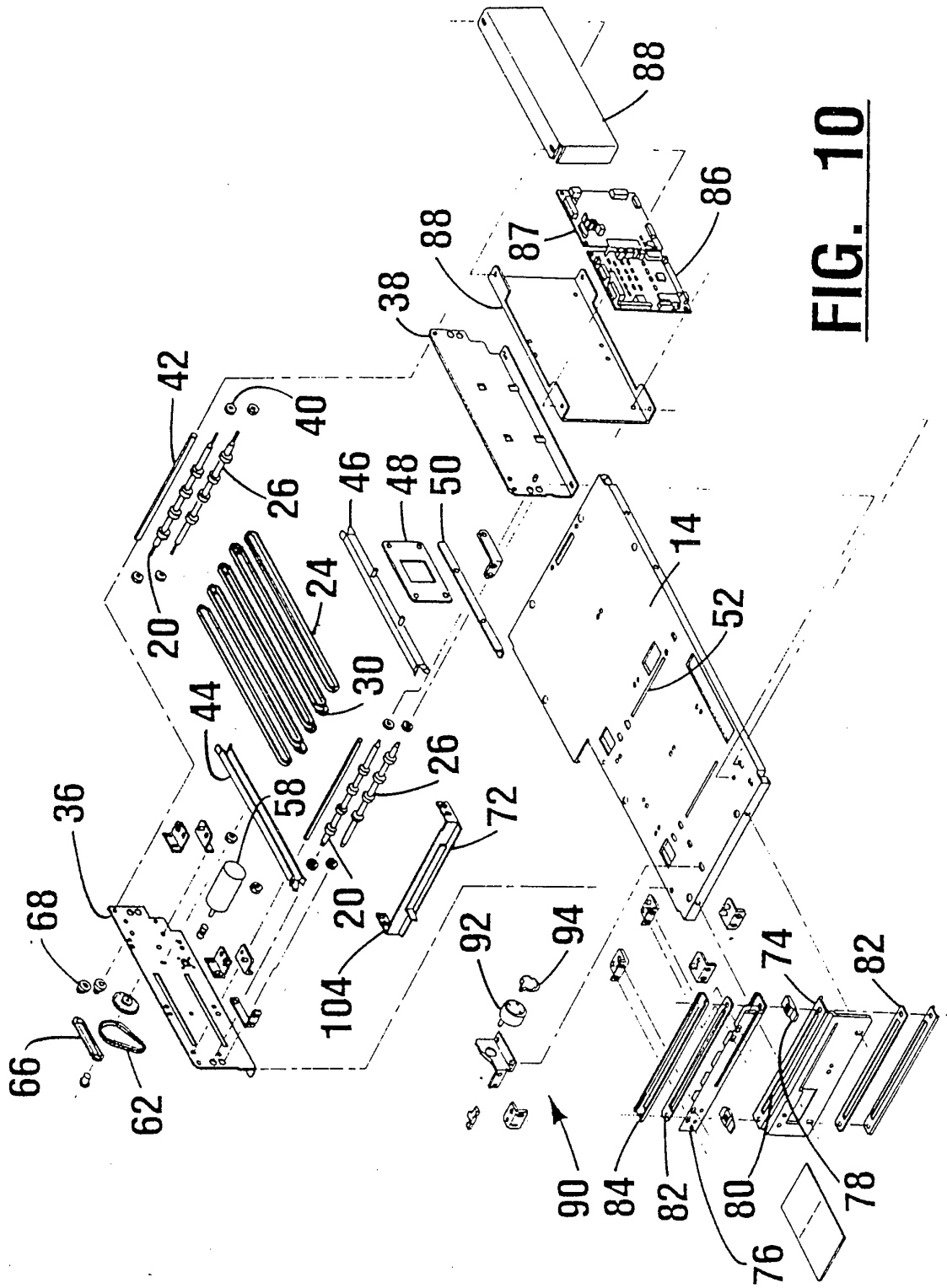

FIG. 10

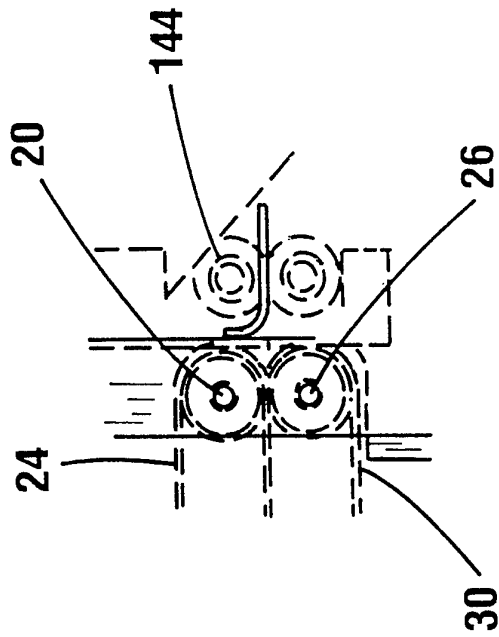

FIG. 11

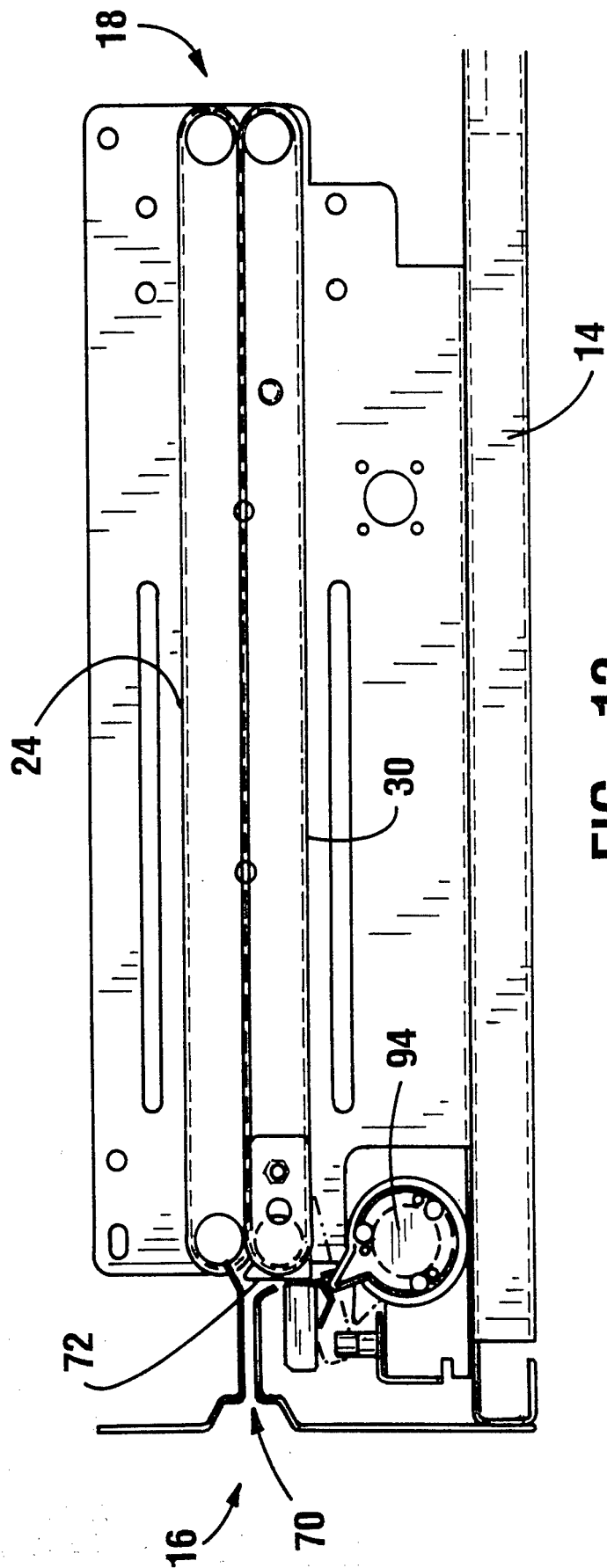

FIG. 12

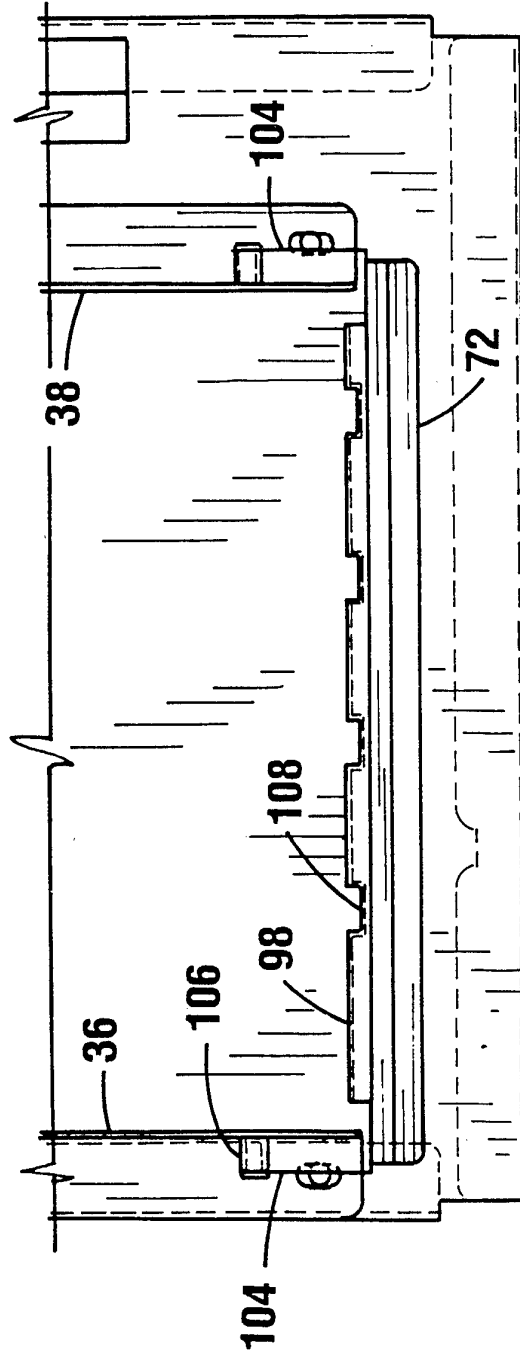

FIG. 13

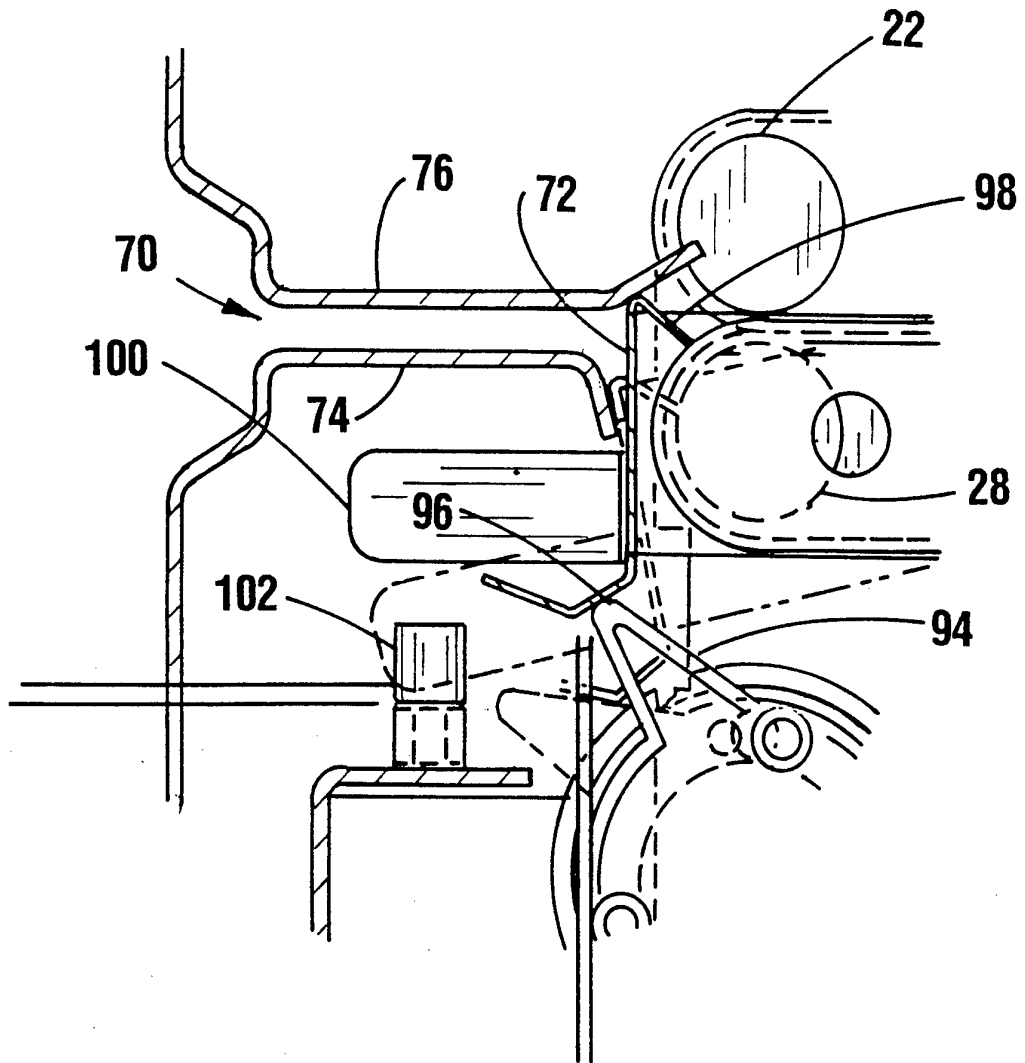

FIG. 14

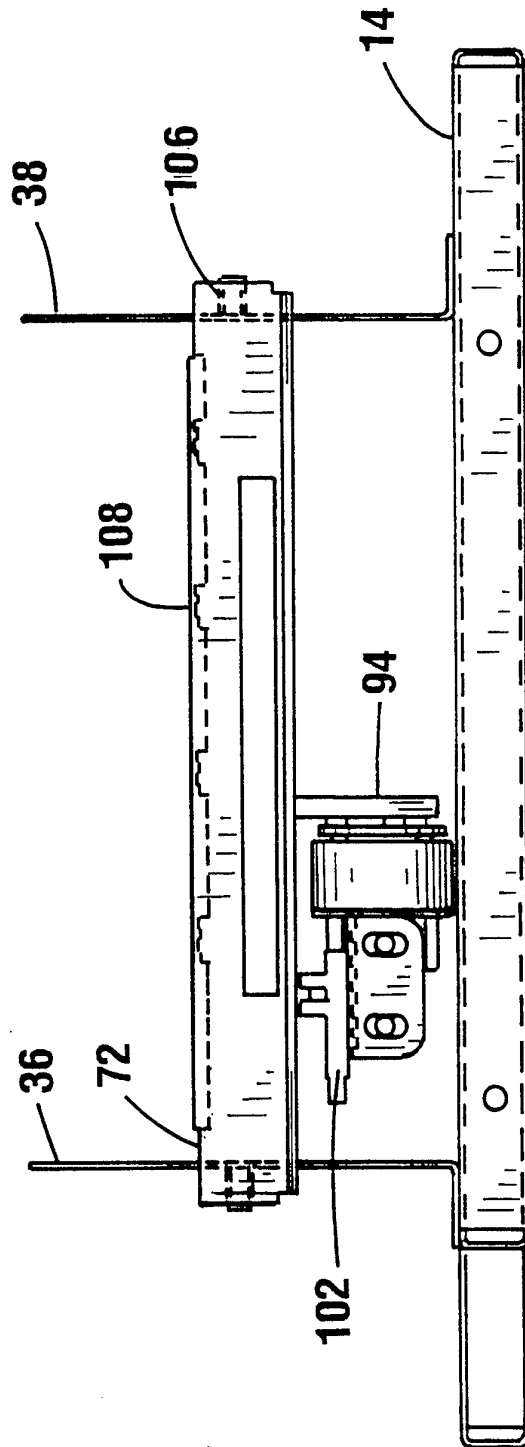

FIG. 15

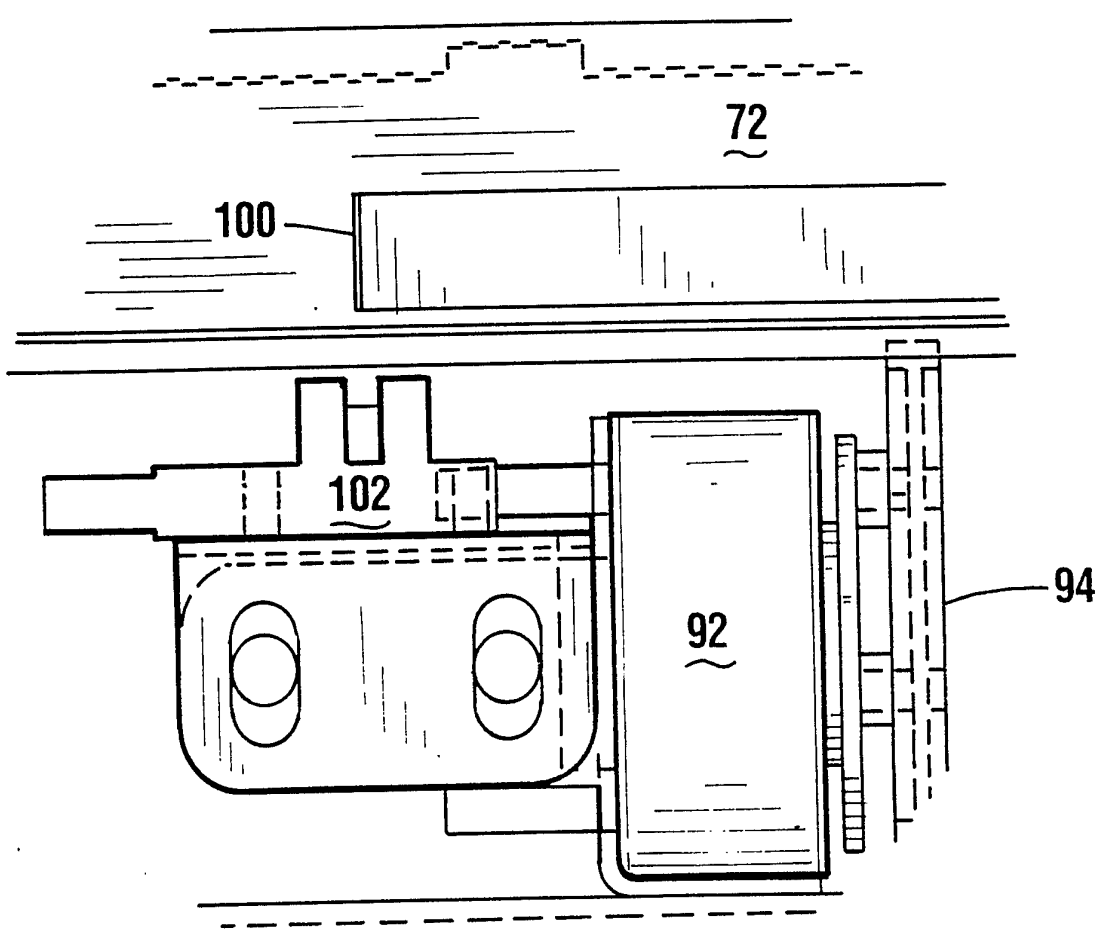

FIG. 16

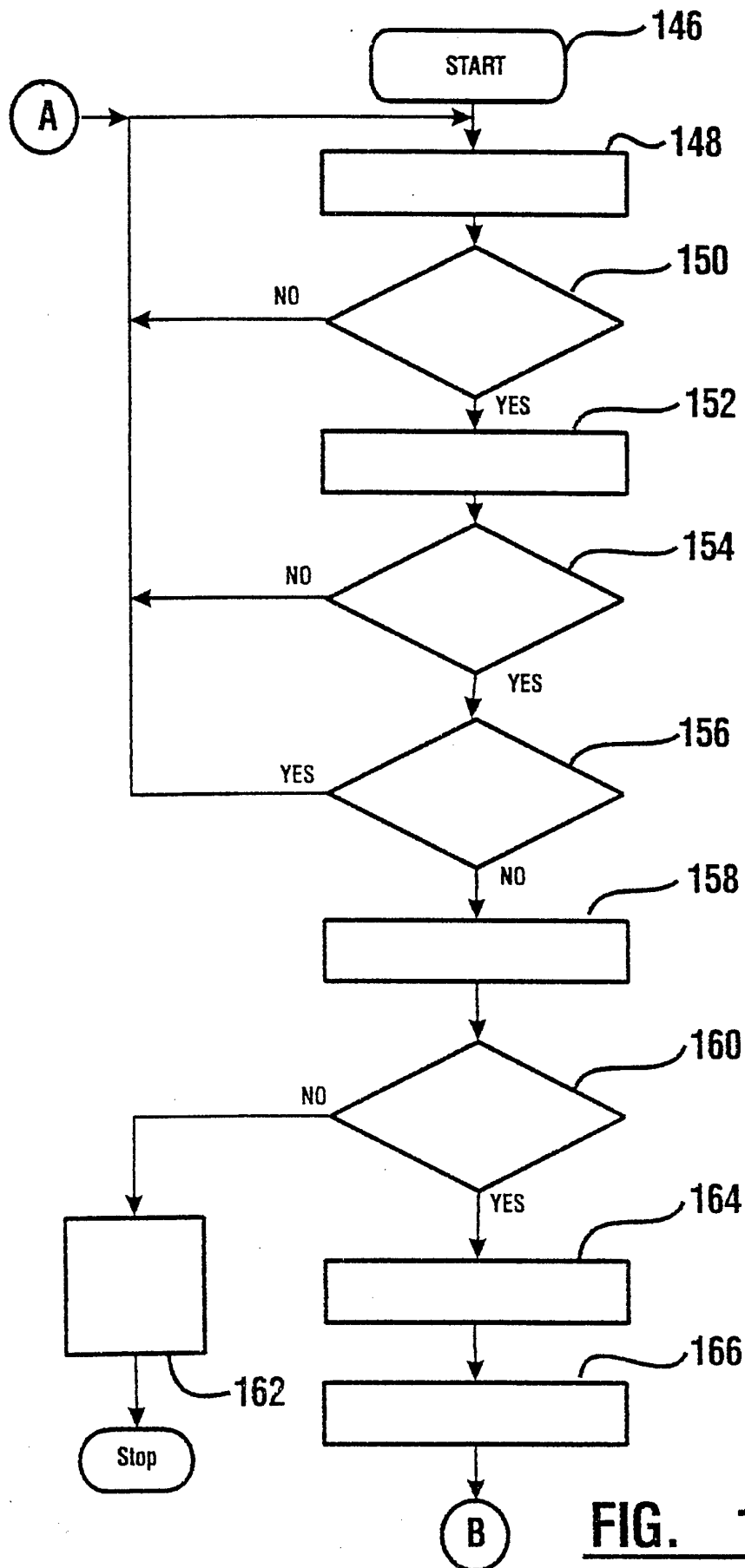

FIG. 17

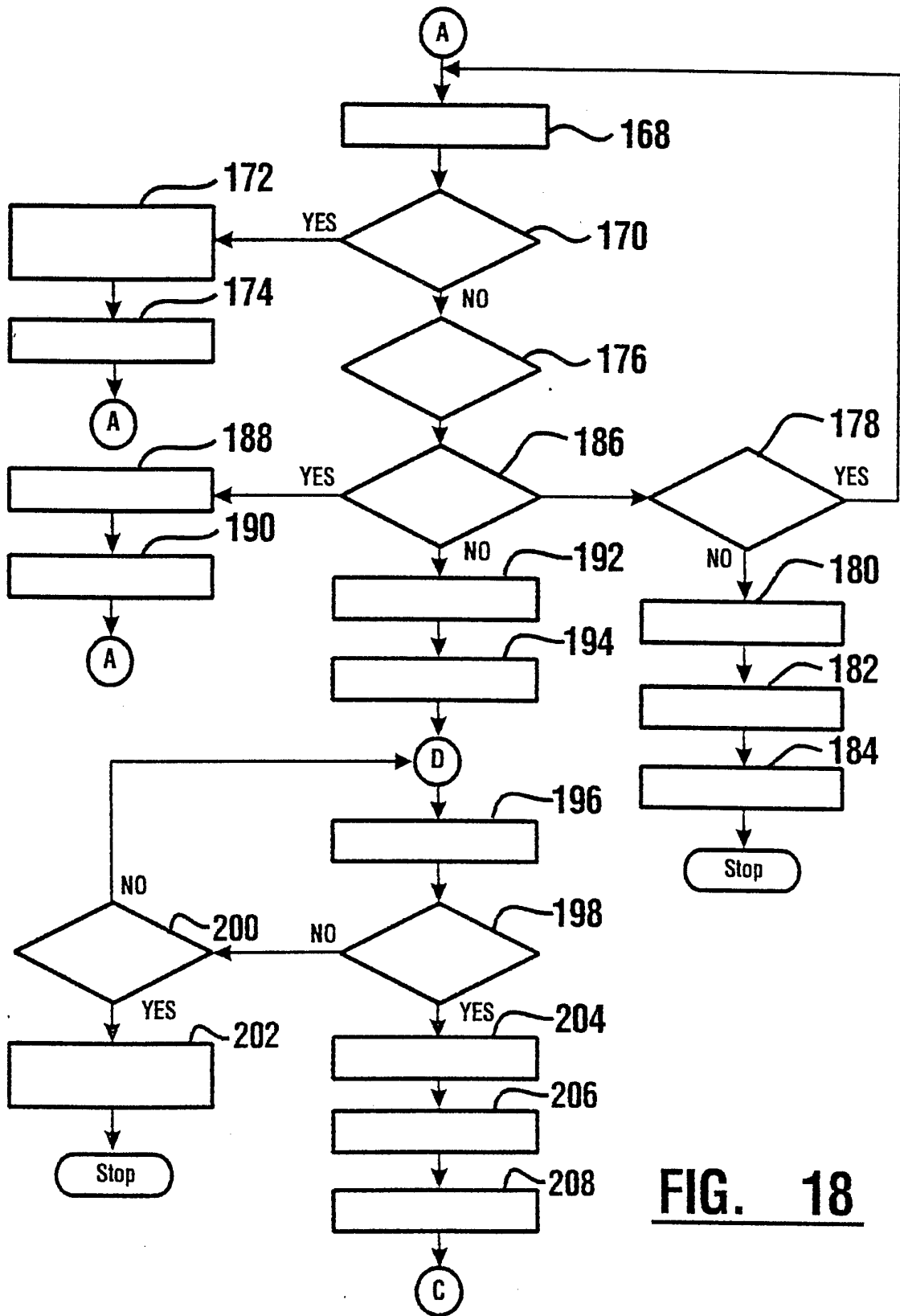

FIG. 18

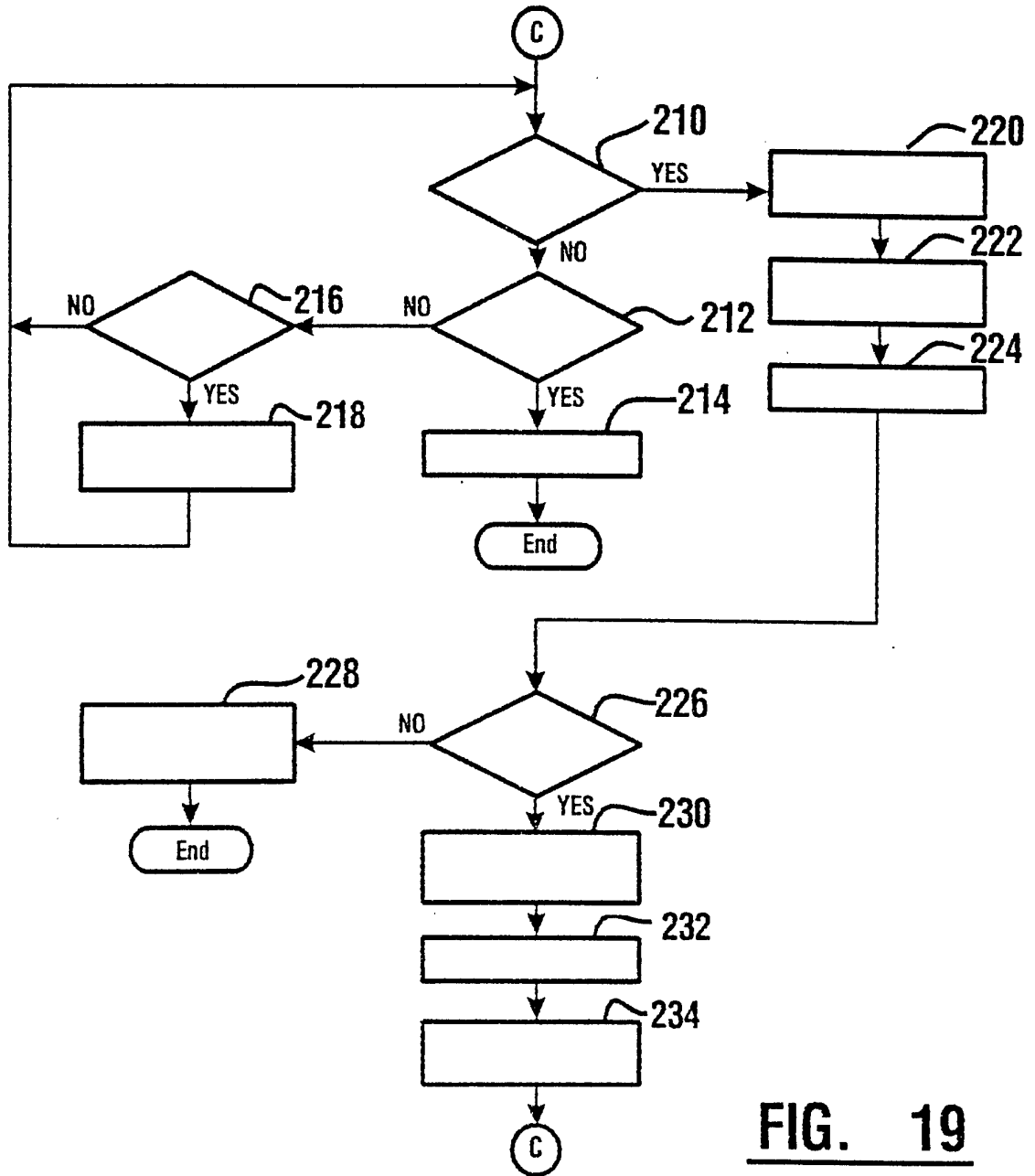

FIG. 19

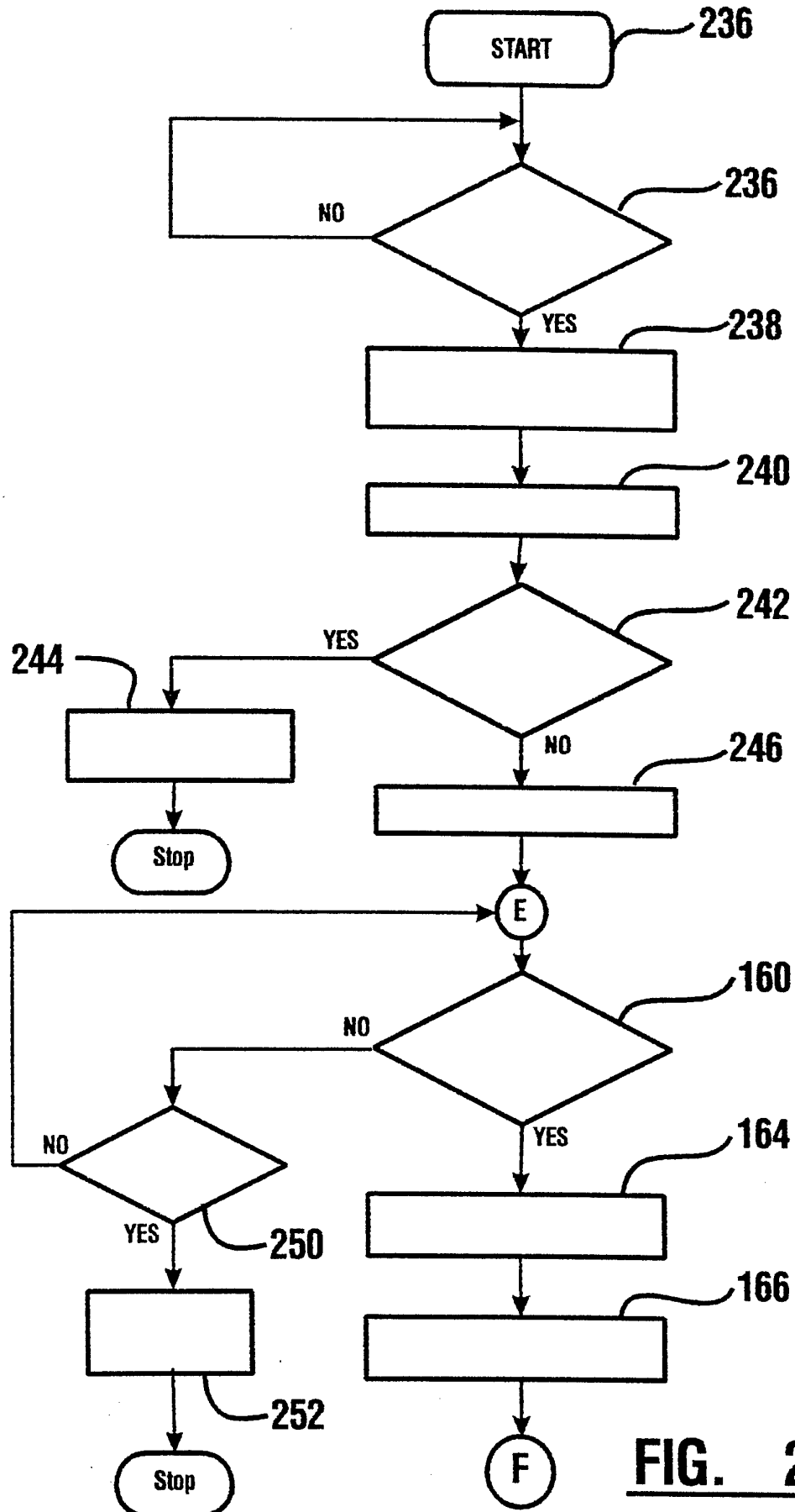

FIG. 20

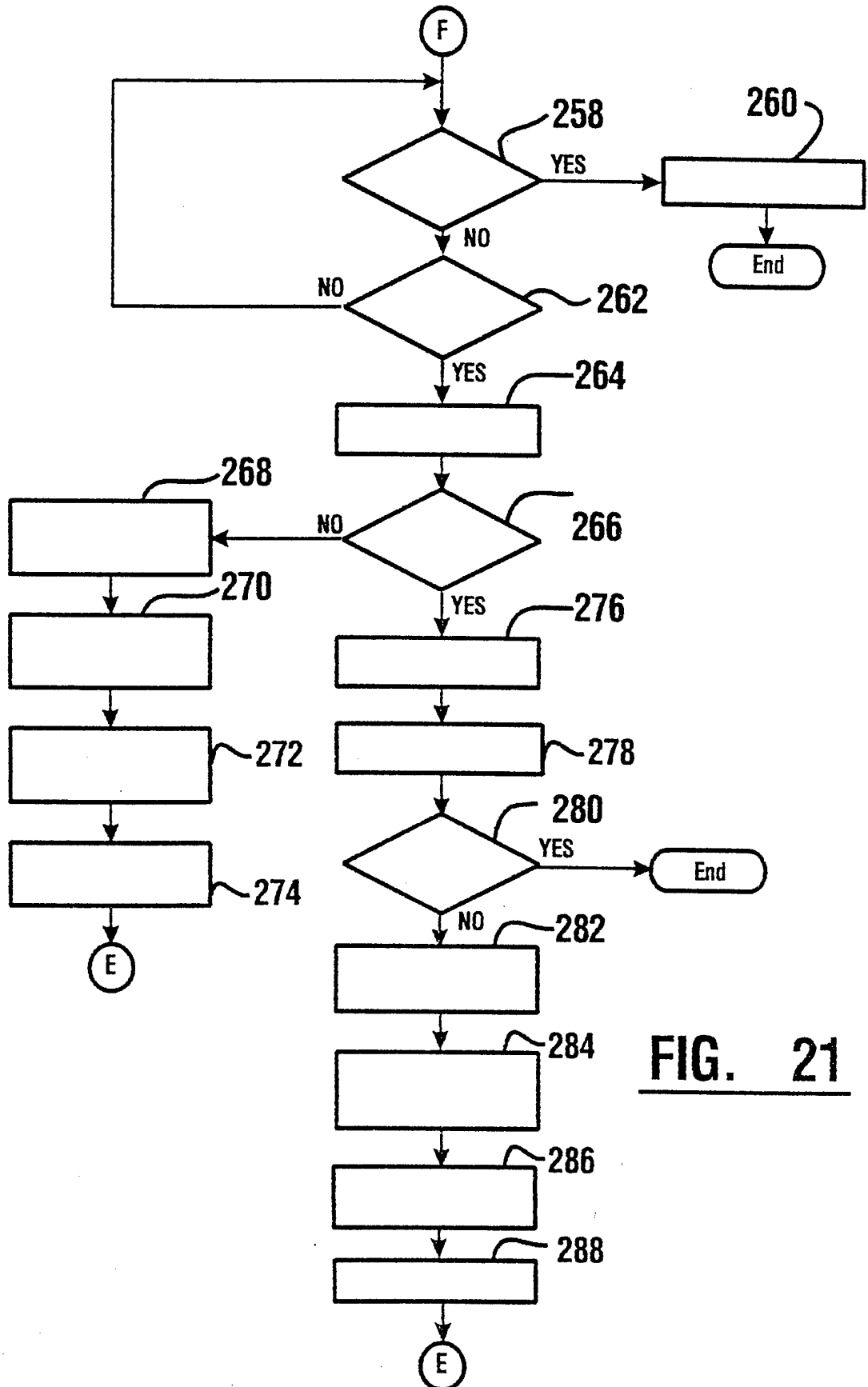

FIG. 21

INTERNATIONAL SEARCH REPORT

International application No.
PCT/US95/07538

A. CLASSIFICATION OF SUBJECT MATTER
 IPC(6) :B65H 9/00
 US CL :271/240, 245, 254, 261, 265.03, 272, 902, 199
 According to International Patent Classification (IPC) or to both national classification and IPC

B. FIELDS SEARCHED
 Minimum documentation searched (classification system followed by classification symbols)
 U.S. : 271/3.15, 3.21, 240, 245, 246, 248, 250, 253, 254, 255, 259, 261, 265.03, 272, 273, 274, 189, 190, 199, 920, 261, 275
 Documentation searched other than minimum documentation to the extent that such documents are included in the fields searched
 NONE
 Electronic data base consulted during the international search (name of data base and, where practicable, search terms used)
 APS word search

C. DOCUMENTS CONSIDERED TO BE RELEVANT

Category*	Citation of document, with indication, where appropriate, of the relevant passages	Relevant to claim No.
Y	US, A, 4,106,767 (Schirrmeister et al) 15 August 1978 (entire document)	1-2, 9-20, 23, 36-43, 48
Y	US, A, 5,091,754 (Abe et al) 25 February 1992 (entire document)	1-2, 9-20, 36-43
Y	JP, A, 3-8641 (Ihai) 16 January 1991 (entire document)	12-13, 16, 41
Y	JP, A, 2-193838 (Koya) 31 July 1990 (entire document)	17-20
Y	JP, A, 58-198244 (Yoshimura) 10 November 1984	48

Further documents are listed in the continuation of Box C. See patent family annex.

* Special categories of cited documents:	*T later document published after the international filing date or priority date and not in conflict with the application but cited to understand the principle or theory underlying the invention
*A document defining the general state of the art which is not considered to be of particular relevance	*X document of particular relevance; the claimed invention cannot be considered novel or cannot be considered to involve an inventive step when the document is taken alone
*E earlier document published on or after the international filing date	*Y document of particular relevance; the claimed invention cannot be considered to involve an inventive step when the document is combined with one or more other such documents, such combination being obvious to a person skilled in the art
*L document which may throw doubts on priority claim(s) or which is cited to establish the publication date of another citation or other special reason (as specified)	*G document member of the same patent family
*O document referring to an oral disclosure, use, exhibition or other means	
*P document published prior to the international filing date but later than the priority date claimed	

Date of the actual completion of the international search 31 JULY 1995	Date of mailing of the international search report 18 AUG 1995
Name and mailing address of the ISA/US Commissioner of Patents and Trademarks Box PCT Washington, D.C. 20231 Facsimile No. (703) 305-3230	Authorized officer <i>H. Grant Skaggs</i> H. GRANT SKAGGS Telephone No. (703) 308-1113

INTERNATIONAL SEARCH REPORT

international application No.
PCT/US95/07538

C (Continuation). DOCUMENTS CONSIDERED TO BE RELEVANT		
Category*	Citation of document, with indication, where appropriate, of the relevant passages	Relevant to claim No.
Y, P	US, A, 5,407,191 (Ukai) 18 April 1995 (entire document)	23
A	US, A, 5,035,415 (Lee et al) 30 July 1991	23
A	US, A, 5,209,467 (Schmaling) 11 May 1993 (entire document)	NONE
A	US, A, 5,098,081 (DeFigueii-edo) 24 March 1992 (entire document)	NONE
A	US, A, 4,850,583 (Monday) 25 July 1989 (entire document)	NONE
A	US, A, 5,165,679 (Kinomoto) 24 November 1992 (entire document)	NONE
A	US, A, 4,279,413 (Siwik et al) 21 July 1981 (entire document)	NONE
A	US, A, 3,999,749 (Zambolin et al) 28 December 1976 (entire document)	NONE