

12 **EUROPEAN PATENT APPLICATION**

21 Application number: 85306182.8

51 Int. Cl.4: F 25 D 17/02

22 Date of filing: 30.08.85

30 Priority: 07.09.84 US 648066  
18.09.84 US 651674

43 Date of publication of application:  
12.03.86 Bulletin 86/11

84 Designated Contracting States:  
BE CH DE FR GB IT LI NL

71 Applicant: CASTLETON, INC.  
Sunrise Tech Center 3235 Sunrise Boulevard Suite C,  
Rancho Cordova California 95670(US)

72 Inventor: Wolf, Terry  
4061 Wagon Master Road  
Placerville California(US)

74 Representative: Westwood, Edgar Bruce et al,  
STEVENS, HEWLETT & PERKINS 5, Quality Court  
Chancery Lane  
London WC2A 1HZ(GB)

54 **Method and apparatus for chilling and freezing articles.**

57 A unit useful for the rapid chilling and/or freezing of small articles, such as beverage cans, other perishable items, other articles desired to be chilled or frozen, and the like products, including an insulated container (40) with a lid (41) therefor, a refrigerator unit (101), heat removing coils (16) disposed within a holding tank for liquid coolant (38); a product chamber (12) above, below or near the coolant holding tank; a pump (18) to move the coolant (38) to or away from the product chamber (12); various means to draw the fluid in or out of the product chamber by means of solenoid valves (44A, 44B) or drain holes (37); a vibrator (22), air blast, rinse cycle to remove undesirable residues; and timer means (5) for controlling the length of time the coolant is within the product and the length of the drain cycle.

The method of rapidly chilling or freezing articles comprising the steps of: chilling a liquid (38) substantially below the freezing temperature of water by refrigeration evaporator coils, said liquid having a very low surface tension, and low residue depositing, such as the family of liquid fluorocarbon chemicals, various alcohol and water formulations ranging from 40% to 60% alcohol which has properties similar to the family of liquid fluorocarbons, being non toxic and nearly odorless, immersing the article to be chilled or frozen into the liquid for a desired period of time, and removing said article therefrom; or in the event of other coolants than those mentioned above are used which leave

an undesirable residue, incorporating a rinse cycle to wash away the residue.

**EP 0 174 170 A2**

FIG. 1

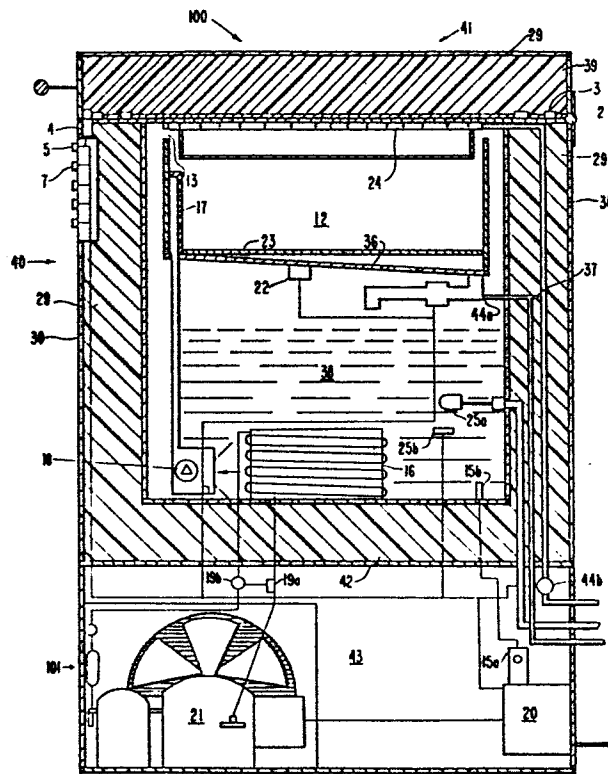

METHOD AND APPARATUS FOR  
CHILLING AND FREEZING ARTICLES

The present invention relates to chillers and freezers, and more particularly, to chillers for small articles such as beverage cans, perishable foods, and the like.

5           Bottled and canned beverage coolers and chillers wherein the bottled or canned beverages are cooled in a body of chilled liquid are not per se new. In fact, numerous U.S. Patents have been issued over the years relating to such  
10           beverage coolers or chillers, some of which are: United States Patent Nos.: 2,287,581 (Hazard); 2,418,300 (Hagstrom); 2,436,426 (Fish); 2,546,417 (Anglin); 2,618,127 (Shyman); 2,812,643 (Woschitz); and 4,377,076 (Staudt, et al.)

15           All of the aforementioned prior art devices relating to beverage cooling utilize water as the chilling fluid with the exception of U.S. Patent No. 2,811,643. Water, even "ice" water, cannot perform the function of extremely rapid  
20           chilling, i.e., properly chill a beverage container in three (3) minutes or less, or cause the articles deposited therein to quick freeze, if desired (as is the case of non-beverage food items). Most are designed and intended for  
25           maintaining the beverages at a particularly desired storage temperature, such as 39.2°F to 50°F, over an indefinite period of time for the

purpose of ensuring that the beverage is properly chilled and always ready for consumption. Because of the use of water as the chilling or cooling liquid these prior art chilling or cooling devices are severely limited in their use and application to non-freezing applications, that is, temperature needs equal to or greater than 32°F, the temperature at which water freezes and becomes ice. Even with the water at or near 32°F, the chilled water must be agitated to prevent the formation of ice. If sufficient ice forms, the entire refrigeration and cooling process will come to a complete halt. Accordingly, most refrigeration systems utilize some sort of instrumented feedback systems to turnoff the refrigeration unit when ice forms to allow the ice to melt before resuming the refrigeration cycle.

While salt-brine can be used to prevent the water from freezing at 32°F, the salt-brine solution leaves an undesirable smell and residue on the article to be chilled and vigorously chemically attacks various metal parts used in the refrigeration unit.

None of the prior art devices related to beverage cooling provide a means for quick freezing of non-beverage articles.

None of the various units here use a non-volatile, chemically-inert chilling or cooling fluid at 25°C STP which does not attack the metal parts typically used in the refrigeration unit.

With respect to the prior art for freezing perishable items such as food, none of the prior

- 3 -

art devices use a liquid--defined as matter that takes a liquid form at 25°C STP. All prior art devices for the freezing of perishable items such as food, use R-12, a Freon compound having a boiling point of -21°F STP, Liquid Nitrogen a boiling point of -320°F STP and Liquid or Solid Carbon Dioxide a boiling point of -109°F STP. None of the prior art relating to the freezing of food uses a liquid as so defined above. They all use chemicals that phase change from a solid or liquid to gas at temperatures and pressures far below desired operating conditions of +32°F to -50°F, the optimum operating temperature being dependent on the exact application, product frozen, and desired result.

None of the prior art devices related to beverage cooling provide a means for eliminating the chilling fluid residue from the articles to be cooled or chilled, whereas the present design uses variations utilizing time, vibration, air, rinse cycle and/or vacuum to eliminate fluid residue.

None of the prior art devices relating to beverage colling utilize a chilling liquid which if beverage liquid contamination occurs, such as by leaking from the beverage container, operates at temperatures far enough below 32°F to immediately convert the beverage material into a solid which by separating it from the chilling liquid, inherently prevents contamination of the chilling liquid medium.

None of the prior art devices known and shown herein utilize a flow header to force chilling medium to flow over and around the product from the walls of the insulated tank or container in which the cooling or chilling liquid is maintained.

In short, none of the prior art chilling or freezing units can function similar to a "reverse" microwave oven wherein the articles are chilled or frozen, as desired, by the extremely rapid removal of heat which is the "reverse" of what a microwave oven does, that is, produce an extremely rapid addition of heat to an article.

Further, in recent years, beverage immersion chillers have been largely replaced by non-liquid immersion (chilled air) refrigeration chilling and/or freezing systems; and currently immersion chillers for freezing food have had to resort to expendable type refrigerants such as LN<sub>2</sub>, CO<sub>2</sub>, R-12, which require complicated and costly recovery systems. Such "non-liquid" refrigeration systems are, however, relatively inefficient with respect to energy usage and cost when compared to liquid immersion-type systems. The heat transferring characteristics of chilled air, or any other "non-liquid" (as defined above), cannot compare with the heat transfer ability of chilled liquids which are 100 to 1000 times more efficient than any air chilling medium. Perhaps the use of the liquid immersion type units fell into disfavor because of the unavailability of a suitable liquid coolant that would not corrode metal, promote algae growth and bacteria, drip

- 5 -

from the product, be contaminated with water soluble impurities, evaporate at 25°F STP. The present design in conjunction with the coolants proposed does not suffer from these deficiencies which have afflicted the prior art concerning immersion chilling or freezing.

However, the need for an improved immersion chilling device which can also function as a rapid freezing device has radically increased over the last few years because of substantially increased electrical energy costs. The use of such air-fluid refrigeration systems to chill or freeze beverages and food articles in even a relatively small convenience package food store can be hundreds of dollars per month, an exorbitant part of the small store owner's monthly overhead and expense. Consequently, it can be readily and easily seen that the lowering of such costs by dispensing with large air storage systems (which have large stand by costs), or expendable type refrigeration systems used in freezing food, and replacing these costly systems with a substantially more efficient liquid immersion chiller or freezer is extremely desirable and cost effective, especially when such devices can chill or freeze product upon demand in minutes and consume very little standby energy when not in use.

It is one object of the present invention herein to provide a method and apparatus for selectively chilling or freezing food and non-food articles as desired.

Another important and primary object of the instant invention disclosed herein is to provide

a method of rapidly chilling and/or freezing articles without leaving an undesirable residue on the chilled or frozen article.

5 It is yet a still further object of the invention herein to provide a method for rapidly chilling or freezing articles while using a chemically inert chilling or freezing liquid at 25°C STP, such as the families of liquid fluorocarbon chemicals, various formulations of alcohol and  
10 water ranging from 40% to 60% alcohol, brines-- glycol, salts and water.

It is an object of the current invention revealed herein to utilize a chilling or freezing liquid medium which evaporates rapidly in the  
15 presence of ambient air (defined as STP--Standard Temperature and Pressure) and leaves no undesirable residue.

Another object of the invention is to use a chilling and/or freezing method which utilizes  
20 a cooling or freezing liquid which has a surface tension characteristic substantially below that of water.

The novel features which are considered as characteristic of the invention are set forth in  
25 particular in the appended claims. The improved cooling and freezing arrangement itself, however, both as to its construction and its mode of operation, together with additional features and advantages thereof, will be best understood upon  
30 perusal of the following detailed description of certain specific embodiments with reference to the accompanying drawings.

BRIEF DESCRIPTION OF THE DRAWINGS:

Fig. 1 is a vertical elevation view of a first embodiment of the invention, shown partially in section, detailing the inside of the insulated cabinet in which the articles to be chilled or frozen are placed and diagrammatically the various elements necessary to chill the liquid and to place the articles to be chilled or frozen therein; and Fig. 2 is a view similar to Fig. 1 showing a second embodiment of the invention.

DESCRIPTION OF THE PREFERRED EMBODIMENT

With reference to Fig. 1 herein, the invention herein is generally indicated at 100 and is referred to as an apparatus for rapidly chilling and/or freezing articles, especially beverage containers and foods 34, including an insulated container 40 having an open top, a lid 41 covering the open top of the container 40, a refrigerated liquid 38 having a relatively low surface tension, such as the family of liquid fluorocarbon chemicals or an alcohol-water mixture ranging from 40% to 60% alcohol or salt or glycol brine solutions, a refrigeration unit, generally indicated at 101, comprising a condensing unit 21, an evaporation assembly 16, and a thermostatic expansion valve assembly 19A and 19B, passageway and pump means 18 for recirculating the liquid 38 to be refrigerated past the evaporator coils and up to the product chamber, a produce chamber 12 for holding the articles to be chilled or frozen, drain holes 36

for the draining the fluid, an overflow drain 13 for handling overflow, a flow header 17 for circulating a directed stream of coolant over the product, a bottom grill 23 for elevating the product out of the draining liquid pool, a vibrator 22 for removing excess undesirable residue, a  
5 rinse header for the same purpose 24, float valve and switch 25A and B to monitor and control liquid coolant level, temperature probe and controller 15A and 15B to control condensor cycle, drain  
10 and rinse solenoids 44A and 44B, necessary electrical switches 5 for controlling product cycle.

The insulated container, generally indicated at 40, is preferably formed of a rectangular structure, having four sidewalls 39 and a bottom  
15 wall 42. The sidewalls 39 and the bottom wall 42 are formed of a thermal insulation type of material 29 having a relatively high R (heat loss resistance) value, such as synthetic plastic foam. Other suitable thermally insulating materials for  
20 the sidewalls 39, bottom wall 42 (as described herein, the lid 41 for the container 40) are all well known per se and, therefore, need not be described in detail. The exterior skin 30 surrounding the sidewalls 38, bottom wall 42, and  
25 the lid 41 of the container 40 is typically formed of stainless steel sheet material which is a relatively poor conductor of heat, or other similar durable, rugged, and self-supporting material. Such self-supporting material provides protection  
30 for the enclosed insulation 29. The insulated

container 40 and lid 41 combination are primarily used for containing the refrigerated liquid 38 which is used to chill or freeze the articles desired. Of course, in the practical sense, the sidewalls 39 are joined to an adjoining cabinet 43 which houses the other portions of the invention herein.

A hinge 2 is mounted along one edge of the lid and is secured to the upper portion of the sidewall 39 of the container 40. A handle 1 is secured along one of the edges of the lid 41 not secured to the hinge 2. The handle 1 allows the hinged lid 41 to be opened and closed as desired for placing the articles to be chilled or frozen therein or to be removed therefrom as desired.

A product holding tray 12 is formed with sidewalls in near conformance with the interior dimensions of the container 40 and a total volume approximately one quarter to one third that of the interior dimensions of the container 40. An overflow drain 13, prevents the liquid from overflowing and returns the liquid to the lower chamber. A plurality of apertures 36 are formed in the bottom of the product tray 12 to allow the refrigerated non residue forming fluid 38 to drain off of the tray 12 after flowing onto the tray by means of pump 18 or gravity so as to permit direct contact with the articles to be chilled or frozen. When using residue producing coolants, a solenoid arrangement not presently described is used to separate coolant return from rinse cycle. Preferably, the tray 12 is formed

of a material which complements, or is identical, to the material forming the skin 30 of the container 40. In the preferred embodiment of the invention set forth herein the material is stainless steel.

5  
10  
15  
20  
25  
30  
Coupled operably to the tray 12 are a pump 18 and flow header 17 to circulate the liquid coolant 38 in a stream over the product, placed in the tray 12. A product immersion grill 20 is attached to the lid 41 so that when the lid is closed the product immersion grill 20 insures that product does not float and remains immersed in the liquid coolant 38 stream flowing out of the flow header 17.

Resting in the chamber is a perforated bottom grill 23, which elevates the product above the bottom of the tray 12 so that circulation of the liquid 38 from the flow header 17 proceeds around the entire product and so that the product remains elevated from drain pools and does not close off the drain holes 36. A vibrator 22 is an optional means of vibrating excess coolant 38 from the product.

Drain and rinse solenoids 44A and 44B are designed to control the rinse header 24 cycle and to prevent undesirable residue and the rinse cycle liquid (H<sub>2</sub>O) from contaminating the liquid 38 in the container 40. A relief orifice 37 drains the rinse cycle liquid (H<sub>2</sub>O) and the undesirable residue, and because it is encased in the insulation liner 29, prevents the rinse cycle water from freezing.

- 11 -

5 A float valve 25A and float switch 25B monitor and control the liquid coolant 38 level so that it does not fall below critical operating levels without triggering an alert beeper or shutting off the unit.

10 To insure air tight seal so that moisture from the atmosphere is not pumped into the system, door lid seals 3 are placed on the bottom of the lid 41 approximately 1/2" from the edge and again a couple of inches from the edge on all sides so as to create an air barrier between the inner and outer lid seal 3.

15 A magnet lid switch 4 which is connected to the pump 18 and where applicable, the drain solenoid 44A, is designed to shut off the pump and/or activate the drain when the lid 41 is raised more than a couple of inches in order to prevent individuals from being able to come into prolonged contact with the liquid coolant 38.

20 The duration of time during which the coolant circulates in the tray 12 containing the articles disposed therein for chilling or freezing is determined in a conventional manner by the use of an electrical timer 5, the output of which is  
25 coupled to the control box assembly 20. An indicator light 7 is operably connected to the timer 5 in conventional well-known fashion and remains "on" or lit as long as the pump 18 is circulating the refrigerated liquid 38 in the tray 12. The  
30 timer 5 output is directed from the control box assembly 20 to the circulation pump 18 and to a beeper.

In a compartment beneath the product chamber 12 is disposed an evaporator or cooling element 16 in the form of a series of coils. The liquid 38 to be refrigerated is pumped by a liquid pump 18 through a passageway beneath the bottom wall of the chamber in the container 40 to the tray 12. The liquid 38 is delivered to the opposite side of said tray 12 by a flow header 17 and by means of drain holes 36 into the compartment containing the evaporator 16. After the liquid 38 passes thereinthrough, it is directed upwards to the tray 12 again by means of the pump 18.

The refrigerating system is conventional which includes a refrigerant liquefying unit comprising an electric motor driving a compressor 21 through conventional belt and pulley connections. A condensor is also provided with a motor-driven fan to drive air thereinover.

A pair of temperature sensing elements 15B and 19B are used to operably control the refrigeration unit in a conventional fashion. The temperature sensing means 15B is positioned within the bottom of the chamber within the container 40 so as to be responsive to the temperature of the body liquid 38 therein, and communicates electrically with a temperature controller 15A for controlling the compressor 21 motor of the refrigeration system. Once activated, the compressor 21 withdraws evaporated refrigerant from the evaporator 16 through the conduit identified as the "low pressure side" and compresses the refrigerant vapor whereupon it is forwarded under pressure through a conduit into the condensor.

Fan driven air is circulated over the condensor and causes condensation of the compressed refrigerant and then flows into the receiver. From the receiver, the condensed refrigerant is conveyed,  
5 by a conduit, to the "high pressure line." Once the temperature of the low pressure line reaches a particular present value, the temperature sensor 19B electrically activates the refrigerant expansion valve 19A thereby allowing the pressurized  
10 refrigerant to pass through the expansion valve 19A to the evaporator or cooling coil 16, thereby chilling the liquid 38 thereabout.

Turning now to Fig. 2 a second embodiment of the invention is shown in which the same reference numerals are used for the same parts  
15 shown in Fig. 1.

Attached to product tray 12 for holding the articles to be chilled or frozen is a double-acting air cylinder means 17, including a shaft  
20 13 which is operably coupled to the product tray 12, and air compressor means 25 for providing a source of compressed air for operating the air cylinder means 17, and an electric solenoid 23 for operably controlling the air delivery to the  
25 air cylinder means 17, including the necessary electrical switches 5 for controlling same.

Operably coupled to the tray 12 is a double-acting air cylinder 17 which is so coupled to the tray 12 by means of a shaft 13 of the air  
30 cylinder 17. Connection is typically made therebetween by means of a threaded shaft end and a nut (not detailed).

- 14 -

The air cylinder 17 and its associated shaft 13 is powered by a supply of compressed air provided by the air compressor 25. The compressed air output from the air compressor 25 is piped directly into an air storage tank 22. The air storage tank 22 is needed to provide a storage plenum, at operating pressure, for the air supply. Without such storage, at pressure, there would not typically be a sufficient quantity of air to operate the pneumatic control systems properly of which the air cylinder 17 is a part.

It should be clearly noted, at this time, that the control system could just as easily be hydraulic. However, the use of a hydraulic system is not necessary and in the event that such a system were to be used, it would cause the weight of the overall system to be substantially increased as well.

Control of the air to the cylinder 17 is accomplished by an electrically-controlled two position solenoid valve 23. When the air cylinder 17 needs to drive the shaft 13 and, of course, the product tray 12 upwardly to its position above the refrigerated liquid 38 level, the solenoid valve 23 is actuated and causes compressed air from the air storage tank 22 to be piped to one of the air lines leading to the air cylinder 17. The compressed air then causes the air cylinder 17 to drive the shaft 13 upwardly as desired. The action of the air cylinder 17 and its associated shaft 13 is reversed, and the tray 12 lowered into the refrigerated liquid 38 to place the articles to be chilled or frozen into

the refrigerated liquid 38, when the solenoid valve 23 is actuated causing compressed air from the air storage tank 22 to be piped to the other of the pipe lines connected between the solenoid valve 23 and the air cylinder 17. The action by the air cylinder 17 to be powered in both directions is referred to as "double action."

When the product tray 12 is elevated by the air cylinder 17 the small magnet 10 mounted appropriately on the outer rim of the top of the rack 12 is placed into close operative proximity to the magnetic switch 9 which, in turn, is electrically connected to the control box assembly 20, and directed therefrom into operative electrical coupling to the solenoid valve 24 which momentarily is opened allowing the compressed air from the air storage tank 22 to be fed via tubing to the air blast header assembly 11 thereby allowing compressed air to exit the apertures 37 in the header assembly 11 to perform the air blasting function previously described.

The duration of time during which the tray 12 and the articles disposed therein for chilling or freezing is determined in a conventional manner by the use of an electrical timer 5, the output of which is coupled to the control box assembly 20. An indicator light 7 is operably connected to the timer 5 in conventional well-known fashion and remains "on" or lit as long as the tray 12 is immersed in the refrigerated liquid 38. The timer 5 output is directed from the control box assembly 20 to the air solenoid 23 which operably directs the solenoid 23 to raise or lower the tray 12 out of or into the refrigerated liquid 38.

An air venting system may, as desired, also be provided which communicates into the inside of the air container 40, consisting of an air vent line 27, an air vent one-way valve 28, and a condensate removal sump and pump assembly 26. Because the lid 41 on the container 40 creates a reasonably air tight condition, the movement of the tray 12 up and down within the closed chamber formed by the combination of the lid 41 and the container 40, a vacuum or higher air pressure can be created within the chamber. To prevent the fluid seal between the lid 41 and the container 40, and other fluid seals found therein as well, from being disturbed and, perhaps, damaged to the point of becoming non-functional this air venting systems is provided. As the air attempts to move out of the chamber, it is diverted down the air vent line 27 to the one-way air vent valve 28 and is vented to atmosphere or the line operably coupled to the condensate removal sump and pump 26. Once it is in the sump and pump 26, it can be easily pumped therefrom.

The refrigerating system is conventional which includes a refrigerant liquefying unit comprising an electric motor driving a compressor 21 through conventional belt and pulley connections. A condensor is also provided with a motor-driven fan to drive air thereinto.

A pair of temperature sensing elements 15B and 19B are used to operably control the refrigerations unit in a conventional fashion. The temperature sensing means 15B is positioned within the bottom of the chamber within the container

40 so as to be responsive to the temperature of  
the body liquid 38 therein, and communicates  
electrically with a temperature controller 15A  
for controlling the compressor 21 motor of the  
5 refrigeration system. Once activated, the com-  
pressor 21 withdraws evaporated refrigerant from  
the evaporator 16 through the conduit identified  
as the "low pressure side", and compresses the  
refrigerant vapor whereupon it is forwarded under  
10 pressure through a conduit into the condenser.  
Fan driven air is circulated over the condenser  
and causes condensation of the compressed refrigerant  
and then flows into the receiver. From the  
receiver, the condensed refrigerant is conveyed,  
15 by a conduit, to the "high pressure line". Once  
the temperature of the low pressure line reaches  
a particular preset value, the temperature sensor  
19B pneumatically activates the refrigerant expansion  
valve 19A thereby allowing the pressurized  
20 refrigerant to pass through the expansion valve  
19A to the evaporator or cooling coil 16, thereby  
chilling the liquid 38 thereabout.

One of the many unique characteristics of  
the present invention disclosed herein includes  
25 the use of a refrigerated liquid in an immersion  
chilling device which is refrigerated to substantially  
below the freezing temperature of water;  
namely: +32°F or 0°C. Neither has there been  
the use of such a refrigerated liquid which is  
30 necessary to significantly reduce or eliminate  
residues from accumulating on the article or  
product to be chilled or frozen. Such a liquid

is the liquid fluorocarbon family, some of which go under the name FREON, which is a brand name for a family of fluorocarbons manufactured by DuPont Co. and typically used in industry as a vapor degreasing agent. Another such liquid is a mixture of alcohol and water ranging from 40% alcohol to 60% alcohol depending on application.

Particularly useful as the selected refrigerated liquid is the liquid fluorocarbon family of chemicals, such as FREON 113 which is approximately double the density of water, has a boiling temperature of +120°F (48.9°C) and freezes at -34° (136.67°C). Further, it is non-toxic to humans when it evaporates it is so dense it hovers close to the ground, and is nonflammable. Its reactive characteristics to metals are compatible with the desired working environment typically found in refrigeration devices, such as aluminum, copper, and the like. Further, it is virtually odorless and tasteless.

The most desired temperature of the refrigerated liquid 38 herein has been found to be in the range of -30°F to -50°F. When the liquid fluorocarbon such as FREON 113 is at 30°F, a standard six pack of carbonated soda, such as a root beer or cola, will chill down completely and begin to freeze in 1 minute 20 seconds of immersion in the refrigeration liquid fluorocarbon.

If it is desired to further reduce the freezing temperature of the liquid fluorocarbons such as FREON, a mixture of various liquid fluorocarbon products can be used to accomplish a further reduced temperature.

- Claims -

- 19 -

1. A method for rapidly chilling or freezing articles in a container with a chilled liquid comprising the steps of:

a) chilling a liquid having a freezing point substantially below 32°F(0°C) to a selected temperature substantially below 32°F(0°C);

b) maintaining a pool of said chilled liquid at said temperature by sensing the temperature of said pool and periodically refrigerating said pool by indirect contact with a refrigerant fluid;

c) placing said articles to be cooled in said container above the surface of said pool;

d) directly contacting said articles with said chilled liquid for a selected period of time;

e) terminating said direct contact of said articles with said chilled liquid; and

f) removing said articles from said above the surface of said pool in said container

2. The method of claim 1, wherein said articles to be chilled or frozen are maintained at a level above the surface of said pool of liquid at all times and said liquid is pumped from said pool, is flooded over said articles and is gravitationally returned to said pool.

3. The method of claim 2, wherein said articles are flushed with water to remove any remaining residue of chilled liquid therefrom and said water is prevented from mixing with said chilled liquid.

4. The method of claim 1, 2 or 3 further comprising the step of vibrating said articles to remove liquid residue therefrom.

5. The method of claim 1, wherein said articles to be chilled or frozen are lowered into and immersed in said pool of liquid for said selected period of time and are then elevated above the surface of said pool of liquid.

6. The method of claim 5, wherein said articles are flushed with a flow of gas after said articles are elevated above the surface of said pool of liquid to remove any remaining residue of said chilled liquid therefrom.

7. The method of any one of the preceding claims wherein said chilled liquid is a liquid fluorocarbon chemical.

8. Apparatus for performing the method of claim 1 comprising:

- a) an insulated container for receiving articles to be chilled or frozen;
- b) a pool of chilling liquid at a lower level in said container, said liquid being inert and having a freezing temperature

- 21 -

substantially below 32°F(0°C);

c) means for maintaining said pool of liquid at a selected temperature substantially below 32°F(0°C);

d) a tray for holding articles to be chilled or frozen at an elevation above the surface of liquid in said pool;

e) means for effecting direct contact between said liquid and said articles to be chilled or frozen; and

f) means for controlling the duration of said direct contact.

9. The apparatus of claim 8, wherein said means for effecting direct contact comprises a flooding chamber at an elevation above said pool, a pump for removing liquid from said pool and a header for discharging liquid from said pump into said flooding chamber to flood said articles.

10. The apparatus of claim 9, wherein said discharged liquid is gravitationally drained from said flooding chamber and returned to said pool.

11. The apparatus of claim 9 or 10, wherein said means for controlling the duration of said direct contact comprises a timer operatively connected to control said pump.

12. The apparatus of claim 9, 10 or 11, further including means for removing liquid residue from said articles comprising a rinse water header disposed above said articles, a conduit for supplying pressurized rinse water to said header and a drain in the bottom of said flood-

ing chamber disposed beneath said articles and above the surface of said pool of liquid.

13. The apparatus of claim 12, further comprising a selectively operable valve in said drain line for returning drained chilling fluid to said pool thereof and for discharging spent rinse water externally of said pool.

14. The apparatus of claim 12 or 13, further comprising a vibrator for vibrating said articles to remove liquid residue therefrom.

15. The apparatus of claim 8, wherein said means for effecting direct contact comprises an elevator connected to said tray for lowering said tray and articles thereon from said elevation above the surface of liquid in said pool to a lower elevation at which said articles are submerged in said pool.

16. The apparatus of claim 15, wherein said means for controlling the duration of said direct contact comprises a timer operatively connected to control said elevator.

17. The apparatus of claim 15 or 16, further including means for removing liquid residue from said articles comprising an air jet header disposed above said articles, and a conduit for supplying pressurized air to said header.

18. The apparatus of any one of claims 8 through 17, wherein said chilling liquid is non-toxic, has a low surface tension and has a high specific gravity.

19. The apparatus of claim 18, wherein said chilling liquid is a liquid fluorocarbon chemical.

20. The apparatus of claim 19, wherein said chilling liquid is FREON 113.

FIG. 1

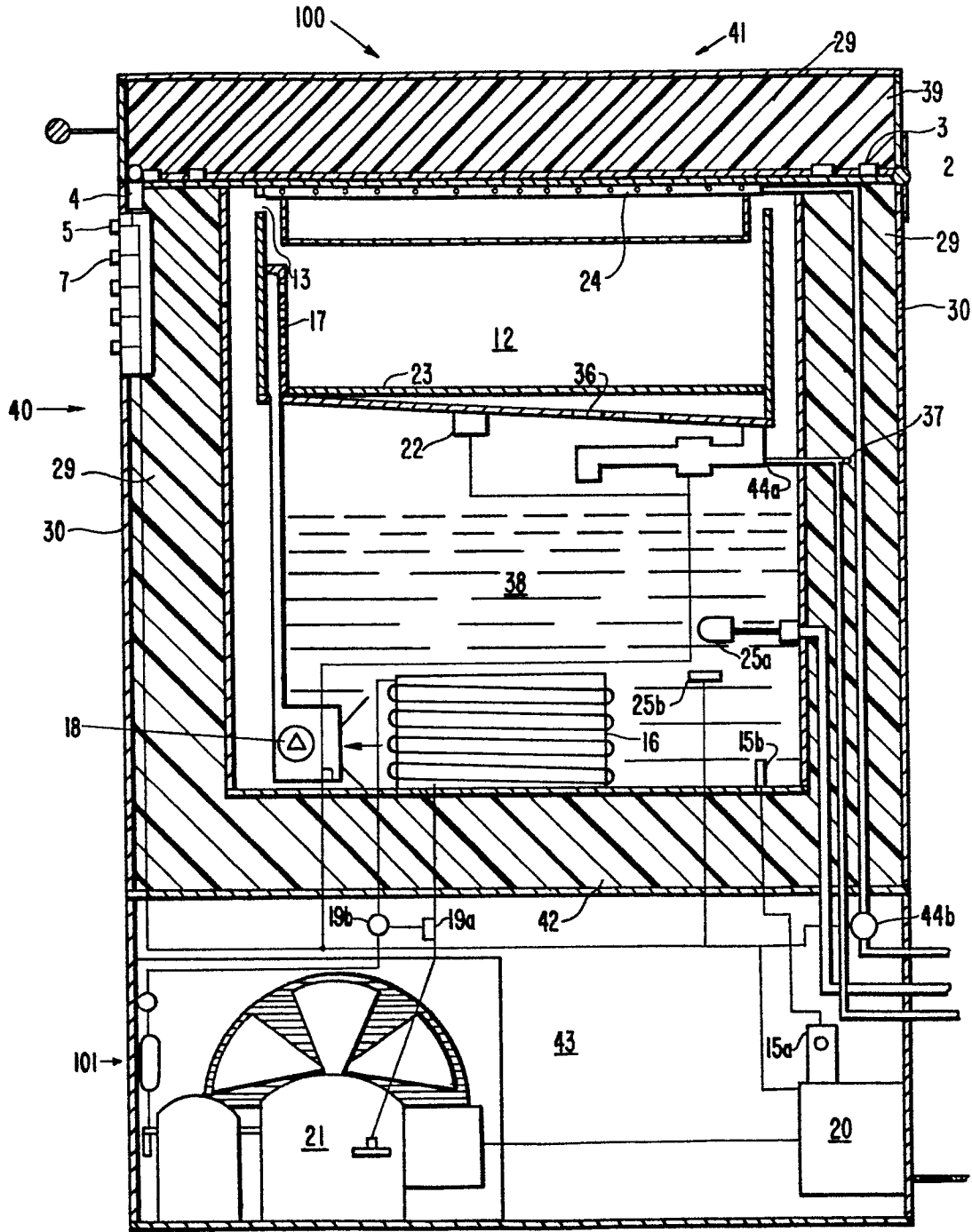

FIG. 2.

