



INTERNATIONAL APPLICATION PUBLISHED UNDER THE PATENT COOPERATION TREATY (PCT)

<p>(51) International Patent Classification³ : E02B 15/04</p>	<p>A1</p>	<p>(11) International Publication Number: WO 83/ 01265 (43) International Publication Date: 14 April 1983 (14.04.83)</p>
<p>(21) International Application Number: PCT/US82/01433 (22) International Filing Date: 5 October 1982 (05.10.82) (31) Priority Application Number: 308,932 (32) Priority Date: 5 October 1981 (05.10.81) (33) Priority Country: US (71) Applicant: TEXAS OIL SPILL CONTROL, INC. [US/US]; P.O. Box 2986, Conroe, TX 77305 (US). (72) Inventor: RYMAL, Theodore, R., Jr. ; P.O. Box 441, Dickinson, TX 77539 (US). (74) Agent: OSTFELD, David, M.; 2401 Fountainview, Suite 500, Houston, TX 77057 (US). (81) Designated States: AT (European patent), AU, BE (European patent), BR, CH (European patent), DE (European patent), DK, FI, FR (European patent), GB (European patent), JP, LU (European patent), NL (European patent), NO, SE (European patent).</p>		<p>Published <i>With international search report.</i> <i>With amended claims.</i></p>
<p>(54) Title: HYDROCARBON RECOVERY SYSTEM</p>		
<p>(57) Abstract</p> <p>A skimming vessel (10) is provided for collecting hydrocarbons or other floating materials, from the surface of a body of water. The floating vessel (10) has an engine (42) driving a prop (41) and is provided with a skimming mode and a traveling mode. A dual skimmer system (17) is provided for skimming the surface of a body of water for collecting hydrocarbons from the surface of the water. The surface of the water is skimmed to capture the floating hydrocarbons by drawing the water through the skimmer (25) (26) with the vessel drive propeller (40) (41) when the vessel (10) is in its skimming mode and the block the passage of water through the skimmer (25) (26) when the vessel (10) is in its travel mode, so that the vessel drive is used to improve the removal of hydrocarbons from the surface of the body of water. The vessel (10) has a passageway or tunnel (34) (35) formed in the bottom thereof for the passage of water and has the prop (40) mounted in the tunnels (34) (35) for drawing water through the tunnels (34) (35) to pull water into the skimming system (17). The tunnel (34) (35) is blocked and the position of at least one skimmer (25) (26) is changed to switch the vessel (10) into a traveling mode for more rapid movement through the water. One or more tunnels (34) (35) can be utilized as desired in the bottom of the vessel (10). An oil/water separator (52) collects the skimmed water and hydrocarbons and separates the mixture. The skimmed oil/water mixture is fed into one tank (72) of a housing (71) having two tanks (72) (74) with a connecting passageway (73). The water then passes through the passageway (73) having a plurality of baffles (80) mounted therein and into the second tank (74). An oil outlet (83) allows the removal of separated oil from the top portion of the second tank (74) while a water outlet (84) allows the removal of water from the bottom portion of the second tank (74). A pair of check valves (77) (78) is mounted between the first tank (72) and the passageway (73).</p>		

FOR THE PURPOSES OF INFORMATION ONLY

Codes used to identify States party to the PCT on the front pages of pamphlets publishing international applications under the PCT.

AT	Austria	LI	Liechtenstein
AU	Australia	LK	Sri Lanka
BE	Belgium	LU	Luxembourg
BR	Brazil	MC	Monaco
CF	Central African Republic	MG	Madagascar
CG	Congo	MR	Mauritania
CH	Switzerland	MW	Malawi
CM	Cameroon	NL	Netherlands
DE	Germany, Federal Republic of	NO	Norway
DK	Denmark	RO	Romania
FI	Finland	SE	Sweden
FR	France	SN	Senegal
GA	Gabon	SU	Soviet Union
GB	United Kingdom	TD	Chad
HU	Hungary	TG	Togo
JP	Japan	US	United States of America
KP	Democratic People's Republic of Korea		

HYDROCARBON RECOVERY SYSTEMBackground of the Invention

This invention relates to a skimming vessel for skimming the surface of a body of water for collecting floating hydrocarbons and water from the surface, feeding it to an oil/water separator and separating the hydrocarbons from the water.

In the past, a wide variety of oil skimming vessels have been provided for skimming the surface of a body of water for collecting oil floating on the surface from oil spills, leaking oil wells, and the like. Boats of this type generally operate on the principal that oil having a lower density than water will float on the water and can thereby be skimmed off. A weir or skimmer is mounted to collect only the surface portion of the water, which is then collected in a tank to give the oil a chance to float to the top where it is removed and the water directed back into the body of water. Skimming vessels of this type typically work in conjunction with floating booms which are connected for directing or collecting the floating oil within the perimeter of the booms. Another common way of collecting and separating oil floating on a body of water is to use a boat having a rotating belt made out of synthetic fiber or other material specially selected for the oil to stick to and which allows the water to run through. The belt can be

-2-

positioned and driven as an endless conveyor with one end protruding into the surface of the water and a squeegee arrangement located at the other end of the endless belt removes the oil collected on the belt which is then dropped into a storage container.

The present invention is for an inexpensive floating vessel operating on a skimming principal which uses the engine propellor for drawing the surface oil/water mixture into the skimming system in one mode and for traveling at a faster rate of speed in a second or traveling mode. The system also provides for a more sophisticated oil/water separator mounted on the floating vessel. Most oil/water separators allow the oil/water mixture to settle in a tank so that the oil will float to the top of the water where it is removed with a pump while the water is removed from the bottom of the tank. One prior oil/water separator adapted for land use can be seen in U.S. Patent No. 4,042,512 to McCarthy, et al., where the oil/water mixture is directed against an angled corrugated surface and then through corrugated baffle members and uses a last-in-last out separator for the oil/water mixture.

The oil/water separator of the present invention utilizes two tanks connected by a passageway in which the oil/water mixture is fed into the first tank, passes through a pair of check valves into the passageway where a plurality of baffles are mounted in a predetermined arrangement. The oil/water



mixture is then fed into the second tank where the oil can be removed from the top and water from the bottom by a simple overflow arrangement.

Summary of the Invention

A skimming vessel for collecting hydrocarbons from the surface of a body of water is provided having a floating vessel with an engine and a driving prop. The vessel has a skimming mode and a traveling mode and a skimming system mounted thereon.

The skimming system skims the surface to collect the mixture of hydrocarbons and water from the surface of a body of water. When the vessel is in a skimming mode, water is drawn through the skimmers through a tunnel formed in the bottom of the vessel by the operation of the vessel propellor. When the vessel is in the traveling mode, the skimmer is repositioned to block skimming and the tunnel is blocked so that the prop drives the vessel more rapidly through the water. An oil/water separator is mounted on the vessel for separating the hydrocarbons from the water in the mixture collected by the skimmer.

An oil/water separator is provided for the vessel having a housing forming a pair of tanks connected by a passageway. The oil/water mixture inlet directs the liquid into one tank which is connected between its ends to the passageway by a pair of



-4-

check valves to allow the flow of liquid into the passageway, but not from the passageway back into the first tank. The passageway has a plurality of predetermined baffles mounted therein for separating oil and water and connects to the middle of the second tank which has an oil outlet connected to the top portion of the tank and an overflow water outlet connected to the bottom portion of the tank.

Brief Description of the Drawing

Other objects, features and advantages of the present invention will be apparent from the written description and the drawings, in which:

Figure 1 is a perspective view of a skimming vessel in accordance with the present invention;

Figure 2 is a side sectional view taken on the line 2-2 of Figure 1;

Figure 3 is a top sectional view taken on the line 3-3 of Figure 1;

Figure 4 is a sectional view taken on the line 4-4 of Figure 5;

Figure 5 is a sectional view taken on the line 5-5 of Figure 4;

Figure 6 is a side sectional view of an alternate embodiment of a skimming vessel;

Figure 7 is a top sectional view of the embodiment of



Figure 6;

Figure 8 is a sectional view of an oil skimming system in accordance with the present invention;

Figure 9 is a sectional view of an alternate prop arrangement;

Figure 10 is an end elevation of a skimming vessel in accordance with the embodiment of Figures 4 and 5;

Figure 11 is a detail of the prop arrangement of the embodiment of Figure 4; and

Figure 12 is a detail of a floating skimmer in accordance with Figure 4.

Description of the Preferred Embodiment

Referring to the drawings and especially to Figure 1, a skimming vessel or boat 10 is illustrated having a hull 11, a cabin 12 and a railing 13 attached to the deck 14. A vessel 10 may provide for auxiliary dinghys 15 and the storage of floating boom sections 16 which can be utilized in connection with the skimming to direct water having oil or other floating materials thereon towards the front skimming portion 17 of the boat 10. The hull 11 can have water discharge openings 18 as well as spotlights 20, an antenna 21, life preserver 22, cleats 23, and other accessories normally found on a vessel. The skimming portion 17 which is located forward on the vessel 10 has a floor portion 24 along with a first hinged floating

skimmer 25 adapted to float when in a skimming position and to ride on the hinges which are hinged to the floor 24 in a skimming mode and to be moved forward to block a portion of the forward opening in a travel mode. A second hinged floating skimmer member 26 is mounted in an opening 27 in the hull 11. In operation, the vessel 10 is adapted to draw an oil/water surface mixture over the skimmer 25 and through the opening 27 over the skimmer 26 where it is directed into an oil/water separator. The hinged, floating skimming members 25 and 26 are adapted to be in position to ride with the level of the water when in a skimming position and to be moved over for blocking the entrance of water when the vessel 10 is in a travel mode.

Figures 2 and 3 show one embodiment of a skimmer vessel, while Figures 4 and 5 show a second embodiment and Figure 6 and 7 show yet a third embodiment of the same basic vessel. Each has the same vessel 10 having a cabin 12 and a skimmer portion 17 on the forward portion of the vessel 10. In figures 2 and 3 a first skimmer member 30, corresponding to member 25 of Figure 1, is shown in a floating position hinged with a hinge 31 and a second skimming member 32, corresponding to member 26 of Figure 1, hinged at 33. In the embodiments of Figures 2 and 3, a pair of tunnels 34 and 35 are connected to the holding area 36. The floating skimmer, in turn, opens into a collection hole 37 from which a pump (not shown) pumps the oil/water mixture into the oil/water separator 38. The tunnels 34 and 35 are connected

-7-

through and along the bottom of the hull 11 and have the propellor and prop portions 40 mounted in tunnel 34 and 41 mounted in tunnel 35. Each propeller and prop 41 is connected to a separate engine 42. The hull 11 also has a hinged gate 43 in each tunnel 34 and 35 which raise and lower simultaneously to connect the prop 40 and 41 into their respective tunnels to draw liquid through the tunnels or alternatively to block off the tunnels to draw liquid directly from the water under the bottom of the boat. When water is being pulled through the tunnels 34 and 35 from the holding area 36, it is pulled from below the water level so that the pump pumping the water through the skimmer 32 into the oil separator 38 is pulling the oil/water mixture on the upper layer into the skimmer 32, hole 37, whereas remaining collected skimmed water is being pulled from below the surface through the tunnels 34 and 35. This creates a suction drawing surface liquid past the skimmer 30 by pulling only surface water from the surrounding body of water. In contrast, skimming vessels not having the drawing action tend to create a wake and push the surface water away from the skimmer opening in front of the boat, thus substantially reducing the effectiveness of a skimming boat riding along a body of water. The present skimming vessel 12 moves slowly when in a skimming mode but draws large amounts of water directly into the front skimming portion of the vessel. However, by dropping the gate 43 and cutting off the tunnels 34



-8-

and 35 and swinging the skimming member 30 forward as shown by the dash lines and swinging the skimming member 32, the vessel 12 can be rapidly converted to a travel mode for much faster travel through the water when not skimming.

Figures 4 and 5 show another embodiment where the vessel 10 has a hull 11 with a floating skimming member 44 hinged with a hinge 45 and mounted to the floor 56 and shown in its travel mode in Figure 4, with dashed lines indicating the skimming mode for the vessel 10. The second floating skimming member 47 is hinged at 48 and a single tunnel 50 is provided along the bottom of the vessel. Water passing the skimmer 47 is pulled into the opening 51 of the oil/water separator 52. In this embodiment, a pair of skimmers 47 is utilized while the tunnel 50 has an opening 53 into the holding area 54 directly beneath the skimming members 47 so that the skimmed water in the holding area 54 passes over the skimmer members 47, which are actually floating weirs, while the water pulled through the tunnel 50 comes from below the surface in the holding area 54 and is pulled through by the propellor 55 mounted to the prop 56. When the gate 57 hinged at 58 is in its raised position as shown in Figure 4, the vessel is in its travel mode so the propellor 55 operates by drawing water surrounding the boat through it for moving the boat to a new location. Dual skimmers 47 each feed into a separate oil/water separator 52 in this embodiment.



Figure 6 and 7 shows yet another embodiment of a vessel 10 having a hull 11 driven by an engine 60 driving a prop 61 to drive a propellor 62 mounted in a single tunnel 63. A hinged floating weir 64 is mounted to the front of the vessel 10 while second floating weirs 65 are mounted to the rear of a holding area 66 and located at each side of the opening of the tunnel 63. Tunnel 63 draws the liquid from beneath holding area 66. Liquid is drawn over weirs 65 and then fed into the oil/water separators 67.

As can be seen at this point, a skimming vessel uses forward and aft weirs for double skimming the surface of the liquid in conjunction with a water tunnel having water drawn therethrough by the drive prop of the vessel while the second skimmer or skimmers takes off the floating mixture in a holding area located between the forward and aft floating weirs, and that by shifting the floating weirs and a gate to the tunnel, the vessel can quickly be converted from a skimming mode to a travel mode. In addition to the skimming a unique oil/water separator is also provided on the vessel. The operation of the oil/water separator can be seen in conjunction with Figure 8.

Turning to Figure 8, an oil/water separator 70 has a housing 71 forming a first tank 72 and a passageway 73 connecting the tank 72 to a second tank 74. An oil/water inlet line 75 feeds the mixture into a funnel portion 76 at the top of tank 72. Inlet line 75 is connected to a pump (not shown)



-10-

which is in fluid communication with hole 37 or the like in the other embodiments. As the oil/water mixture pours into the tank 72 it begins to separate with the oil floating to the top. Between the ends of the tank 72, a passageway 73 is connected thereby to an upper check valve 77 and a lower check valve 78 which is used to maintain the already partially separated oil and water as it proceeds through the passageway 73 and to prevent it from flowing back in to the tank 72. The plurality of angled baffles 80 are mounted in the passageway 73 angled for the rising oil to float over the top area 81 of the baffles 80 while the water can pass under the baffles 80 through the passage 82. The baffles 80 need to be made of materials having oil adhesive characteristics, such as acrylic polymers. The water and oil thus proceed through a series of baffles, as shown, into the tank 74 where the oil tends to be substantially separated and rises to the upper portion of the tank 74 while the water tends to stay in the bottom of the tank 74. Along the upper part of the tank 74 is an oil outlet 83 and a water outlet 84. The water outlet is connected to an elongated water pipe 85 extending down near the bottom of the tank 74 so that when the tank fills up sufficiently for the oil to leave the outlet 83, the water will also flow out or overflow from the pipe 84. Thus, a pump is not required to remove the oil and water even though a pump is used to raise the mixture to the inlet 75. A vent pipe 86 is connected to the pipe 85 and acts



-11-

as a siphon break to prevent a siphon from being generated and thereby emptying the tank 74.

Figure 9 shows an alternate embodiment of switching the vessel 10 from a travel to a skimming mode and has a hull 11 with a tunnel 90 and an arm 91 hinged at 92 to the hull and an arm 104 hinged separately to the hull. The vessel 10 has a transom 98 and a prop 94 connected to an engine 95. The prop is connected by means of drive line 96 to the engine 95 and to the propellor 97. The prop 94 is mounted in a support box 102, which box is held by linkage members 91 and 104. A hydraulic cylinder 100 is mounted to a hinged point 101 of arm 91 and thereby drops the arm 91 and the hinged box 102, as well as the prop 94 and propellor 97, blocking the tunnel 90 and lowering the propellor 97 to a more efficient position below the hull 11. The drive shaft 96 has a pair of universal joints 103 and 106 connected to gear box 107 and attached to the prop 94. It should, of course, be clear that the illustrated linkage members 104 and 91 and cylinder 100 are each one of a pair supporting the box 102 from both sides.

Turning now to Figure 10, an end view of the vessel of Figures 4 and 5 is illustrated having a transom 110 with the propellor 55 protruding from the tunnel 50 and having the oil/water separators 52 mounted thereover.

Figure 11 shows the preferred embodiment for changing the prop operation from skimming to travel mode and is a detail



-12-

from Figure 4, in which the tunnel 50 is in line with the propellor 55 connected to the prop 56. A gate 57 is hinged at 58 and supported by hydraulic cylinder 111, pinned to a bracket 112 and is adapted to raise or lower the gate 57 relative to the hull 11 to pen or block the tunnel and to position the propellor 55 for skimming or to block the tunnel 50 for traveling.

Figure 12 shows an enlarged section taken from Figure 4 of the floating weir 47 which may be made of a material having flotation therein which is hinged with a hinge 48 and has a travel mode position as shown in Figure 12, and a skimming mode as shown by dashed lines. Water is skimmed over the skimming member 47 and is drawn into the opening 51 of the oil/water separator 52 mounted on the hull 11.

It should be clear at this time that a skimming vessel as well as an oil/water separator have been provided which advantageously provides an effective double skimming prior to entering the oil/water separator which provides a more effective separation of the oil and water being collected on the surface of a body of water. It will, of course, be clear that collected, separated water is dumped back into the body of water, while separated oil is temporarily stored until it can be removed from the vessel.

Accordingly, the present invention is not to be construed as limited to the forms shown, which are to be considered



illustrative rather than restrictive.



I Claim:

1. A skimming vessel for collecting hydrocarbons from the surface of a body of water comprising:

a floating hull having a power source and a driving propellor connected together, said hull having boat means for operating the hull in a skimming mode and a traveling mode;

said boat means including skimming means for skimming the surface of the water for collecting hydrocarbons from the surface of the water, said skimming means including means to draw water therethrough by said propellor when said boat means is operating in the skimming mode and to block the passage of water through said skimming means when said boat means is operating in the travel mode, whereby the vessel propellor is used to improve the removal of hydrocarbons from the surface of a body of water; and

separating means for separating hydrocarbons from skimmed water collected by said skimming means.

2. A skimming vessel in accordance with Claim 1, in which said skimming means further includes at least one tunnel passing through the bottom portion of said hull and positioned for said propellor to draw water therethrough.

3. A skimming vessel in accordance with Claim 2, in



-15-

which said hull has a second propellor connected to said power source andd skimming means includes two tunnels, each having one of said propellors positioned therein for drawing water therethrough.

4. A skimming vessel in accordance with Claim 2, in which said skimming means further includes at least two skimmers spaced apart from each other with a holding area in between and wherein said first skimmer is a forward skimmer for skimming the surface of the water and the second skimmer is an aft skimmer positioned to skim water in said holding area between said skimmers.

5. A skimming vessel in accordance with Claim 4, in which said tunnel is connected at one end to said holding area below the normal level of the surface of liquid in said holding area and extending through the bottom portion of said hull to the rear end portion of said hull.

6. A skimming vessel in accordance with Claim 2, in which a gate is mounted to block said tunnel in one position and to open said tunnel in the other position.

7. A skimming vessel in accordance with Claim 6, in which said gate is hinged and swings upward to block said



tunnel.

8. A skimming vessel in accordance with Claim 7, in which said swinging gate is supported by at least one hydraulic cylinder which shifts said gate between a tunnel blocking position when said boat means is in a traveling mode and a tunnel open position when said boat means is in a skimming mode.

9. A skimming vessel in accordance with Claim 4, in which said forward skimmer is hinged to the bottom of said hull and has flotation material therein thereby acting as a floating weir.

10. A skimming vessel in accordance with Claim 9, wherein said hull has a forward opening and which said forward skimmer is adapted to swing forward to partially block said forward opening when said boat means is in a traveling mode.

11. A skimming vessel in accordance with Claim 4, in which said skimming means includes a second aft skimmer, each of said aft skimmers positioned to skim liquid in said holding area.

12. A skimming vessel in accordance with Claim 11, in



-17-

which each of said aft skimmers is connected to skim the surface of the liquid in said holding area as a separate oil/water separator on said hull.

13. A skimming vessel in accordance with Claim 1, in which said separating means includes an oil/water separator having a housing forming a pair of tanks connected by a passageway and having means for having the skimmed water flow through said first tank and then through said passageway into said second tank and said second tank having an oil outlet for discharging oil collected therein and a water outlet for discharging water collected therein.

14. A skimming vessel in accordance with Claim 13, in which said oil/water separator includes at least one check valve mounted between said first tank and said passageway.

15. A skimming vessel in accordance with Claim 14, in which a pair of check valves are mounted between said first tank and said passageway.

16. A skimming vessel in accordance with Claim 15, in which said oil/water separator includes a plurality of baffles mounted at angles along said passageway adapted for oil to move over said baffles and water to pass thereunder.



17. An oil/water separator in accordance with Claim 15, in which said second tank has a water overflow pipe extending from the bottom portion thereof to a level approximately the same position as said oil outlet and has a siphoned break therein.

18. A skimming vessel in accordance with Claim 1, in which said skimming means includes draw means for drawing water through said propellor, said draw means including a prop, a swinging gate and a drive shaft, said prop connected by said drive shaft to said power source and said drive shaft having at least one universal joint and said prop being mounted to said swinging gate for shifting said propellor and prop between the skimming mode and travel mode.

19. A skimming vessel in accordance with Claim 18, in which said hull includes a tunnel therethrough from said skimming means to the back of said hull and said gate is positioned to open and close said tunnel and in which said drive shaft has a second universal joint therein and said prop is shifted by shift means with said gate for opening or closing said tunnel simultaneously with the raising and lowering of said prop.



-19-

20. A skimming vessel in accordance with Claim 19, in which said shift means includes a hydraulic cylinder attached to said gate for raising or lowering said propellor prop and said gate simultaneously.

21. An oil/water separator comprising in combination:
a housing forming a pair of tanks connected by a passageway;

oil/water mixture inlet in one tank of said housing;
check valve means between said one tank and said passageway between said tanks;

a plurality of baffles mounted in predetermined positions in said passageway between said tanks;

an oil outlet from the top portion of said other tank; and
a water outlet from said other tank, whereby an oil/water mixture fed into said one tank begins separating in said one tank and through a series of baffles dividing the oil from the water in said passageway for separate removal from said other tank.

22. An oil/water separator in accordance with Claim 21, in which said check valve means includes a pair of check valves mounted one above the other.

23. An oil/water separator in accordance with Claim 22,



-20-

in which said oil/water mixture inlet includes a funnel shaped inlet having a pipe inlet feeding therein which directs said mixture into said first tank.

24. An oil/water separator in accordance with Claim 23, in which said plurality of baffles are mounted at an angle leaving a space above and below each of said baffles.

25. An oil/water separator in accordance with Claim 24, in which said water outlet from said other tank includes a pipe extending from the bottom portion of said tank to a level approximately the same as said oil outlet and has a vent pipe to form a siphon break whereby said oil and water are discharged with overflow pipes.



AMENDED CLAIMS

(received by the International Bureau on 28 January 1983 (28.01.83))

1. (Amended) A skimming device for collecting hydrocarbons from the surface of a body of water comprising:

a floating hull having a power source and a driving propellor connected together, said hull having boat means for operating the hull in a skimming mode and a traveling mode;

said boat means including skimming means for skimming the surface of the water for collecting hydrocarbons from the surface of the water, said skimming means including means to draw water therethrough by said propellor when said boat means is operating in the skimming mode and to block the passage of water through said skimming means when said boat means is operating in the travel mode, whereby the vessel propellor is used to improve the removal of hydrocarbons from the surface of a body of water; and

separating means for separating hydrocarbons from skimmed water collected by said skimming means.

2. (Amended) A skimming device in accordance with Claim 1, in which said skimming means further includes at least one tunnel passing through the bottom portion of said hull and positioned for said propellor to draw water therethrough.

3. (Amended) A skimming device in accordance with Claim 2, in which said hull has a second propellor connected to said power source and skimming means includes two tunnels, each having one of said propellers positioned therein for drawing water therethrough.

4. (Amended) A skimming device in accordance with Claim 2, in which said skimming means further includes at least two skimmers spaced apart from each other with a holding area in between and wherein said first skimmer is a forward skimmer for skimming the surface of water and the second skimmer is an aft skimmer positioned to skim water in said holding area between said skimmers, said second skimmer having an area



facing said holding area which is substantially smaller than the area of said first skimmer facing said holding area.

5. (Amended) A skimming device in accordance with Claim 4, in which said tunnel is connected at one end to said holding area below the normal level of the surface of liquid in said holding area and extending through the bottom portion of said hull to the rear end portion of said hull.

6. (Amended) A skimming device in accordance with Claim 2, in which a gate is mounted to block said tunnel in one position and to open said tunnel in the other position.

7. (Amended) A skimming device in accordance with Claim 6, in which said gate is hinged and swings upward to block said tunnel.

8. (Amended) A skimming device in accordance with Claim 7, in which said swinging gate is supported by at least one hydraulic cylinder which shifts said gate between a tunnel blocking position when said boat means is in a traveling mode and a tunnel open position when said boat means is in a skimming mode.

9. (Amended) A skimming device in accordance with Claim 4, in which said forward skimmer is hinged to the bottom of said hull and has flotation material therein thereby acting as a floating weir.

10. (Amended) A skimming device in accordance with Claim 9, wherein said hull has a forward opening and in which said forward skimmer is adapted to swing forward to partially block said forward opening when said boat means is in a traveling mode.

11. (Amended) A skimming device in accordance with Claim 4, in which said skimming means includes a second aft skimmer, each of said aft skimmers positioned to skim liquid in said holding area.



12. (Amended) A skimming device in accordance with Claim 11, in which each of said aft skimmers is connected to skim the surface of the liquid in said holding area as a separate oil/water separator on said hull.

13. (Amended) A skimming device in accordance with Claim 1, in which said separating means includes an oil/water separator having a housing forming a pair of tanks connected by a passageway and having means for having the skimmed water flow through said first tank and then through said passageway into said second tank and said second tank having an oil outlet for discharging oil collected therein and a water outlet for discharging water collected therein.

14. (Amended) A skimming device in accordance with Claim 13, in which said oil/water separator includes at least one check valve mounted between said first tank and said passageway.

15. (Amended) A skimming device in accordance with Claim 14, in which a pair of check valves are mounted between said first tank and said passageway.

16. (Amended) A skimming device in accordance with Claim 15, in which said oil/water separator includes a plurality of baffles mounted at angles along said passageway adapted for oil to move over said baffles and water to pass thereunder.

17. (Amended) A skimming device in accordance with Claim 15, in which said second tank has a water overflow pipe extending from the bottom portion thereof to a level approximately the same position as said oil outlet and has a siphon break therein.

18. (Amended) A skimming device in accordance with Claim 1, in which said skimming means includes draw means for drawing water through said propellor, said draw means including a prop, a swinging gate and a

drive shaft, said prop connected by said drive shaft to said power source and said drive shaft having at least one universal joint and said prop being mounted to said swinging gate for shifting said propellor and prop between the skimming mode and travel mode.

19. (Amended) A skimming device in accordance with Claim 18, in which said hull includes a tunnel therethrough from said skimming means to the back of said hull and said gate is positioned to open and close said tunnel and in which said drive shaft has a second universal joint therein and said prop is shifted by shift means with said gate for opening and closing said tunnel simultaneously with the raising and lowering of said prop.

20. (Amended) A skimming device in accordance with Claim 19, in which said shift means includes a hydraulic cylinder attached to said gate for raising or lowering said propellor prop and said gate simultaneously.

21. An oil/water separator comprising in combination:
a housing forming a pair of tanks connected by a passageway;
oil/water mixture inlet in one tank of said housing;
check valve means between said one tank and said passageway between said tanks;

a plurality of baffles mounted in predetermined positions in said passageway between said tanks;

an oil outlet from the top portion of said other tank; and

a water outlet from said other tank, whereby an oil/water mixture fed into said one tank begins separating in said one tank and through a series of baffles dividing the oil from the water in said passageway for separate removal from said other tank.



22. An oil/water separator in accordance with Claim 21, in which said check valve means includes a pair of check valves mounted one above the other.

23. An oil/water separator in accordance with Claim 22, in which said oil/water mixture inlet includes a funnel shaped inlet having a pipe inlet feeding therein which directs said mixture into said first tank.

24. An oil/water separator in accordance with Claim 23, in which said plurality of baffles are mounted at an angle leaving a space above and below each of said baffles.

25. An oil/water separator in accordance with Claim 24, in which said water outlet from said other tank includes a pipe extending from the bottom portion of said tank to a level approximately the same as said oil outlet and has a vent pipe to form a siphon break whereby said oil and water are discharged with overflow pipes.



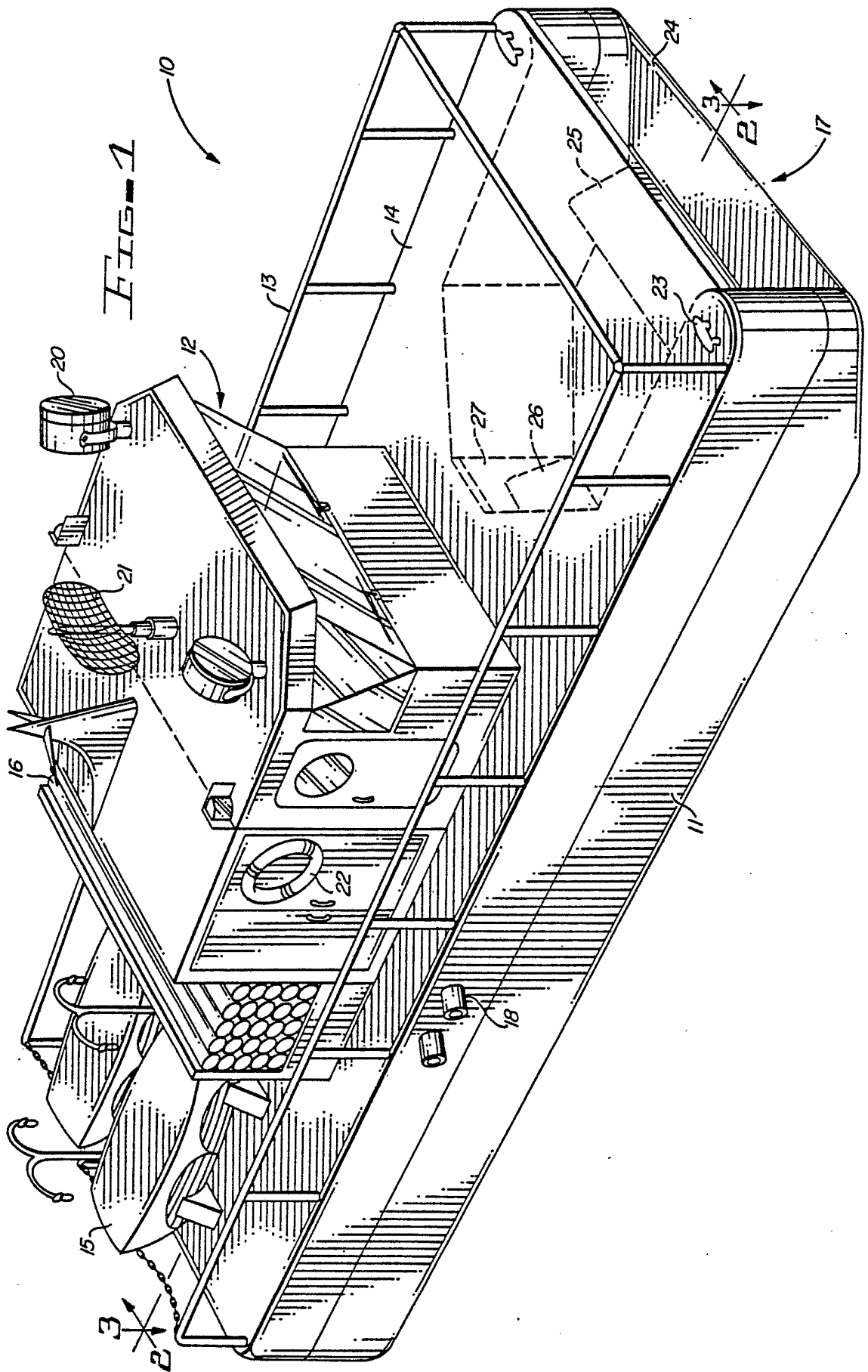

215

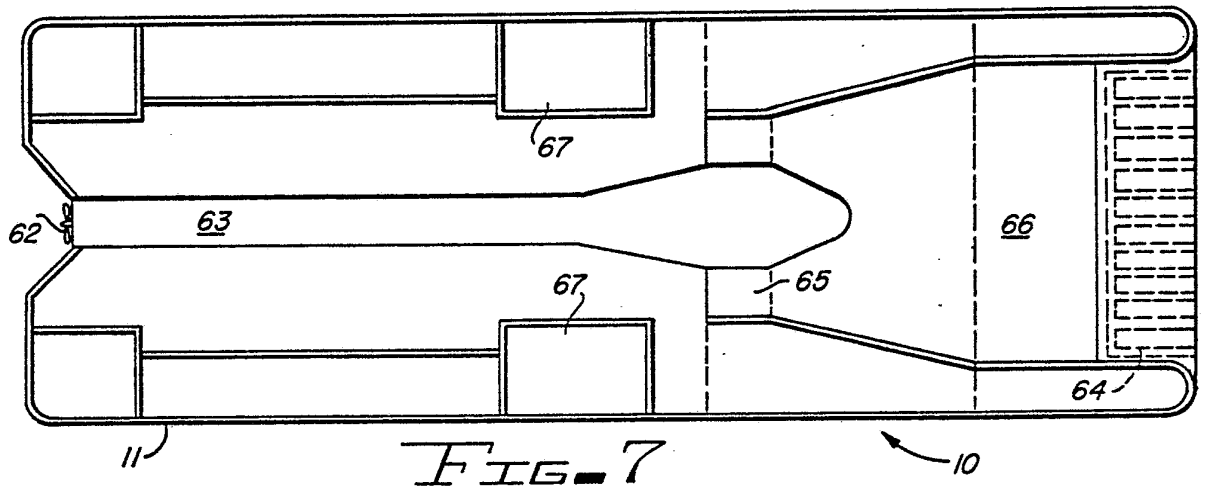
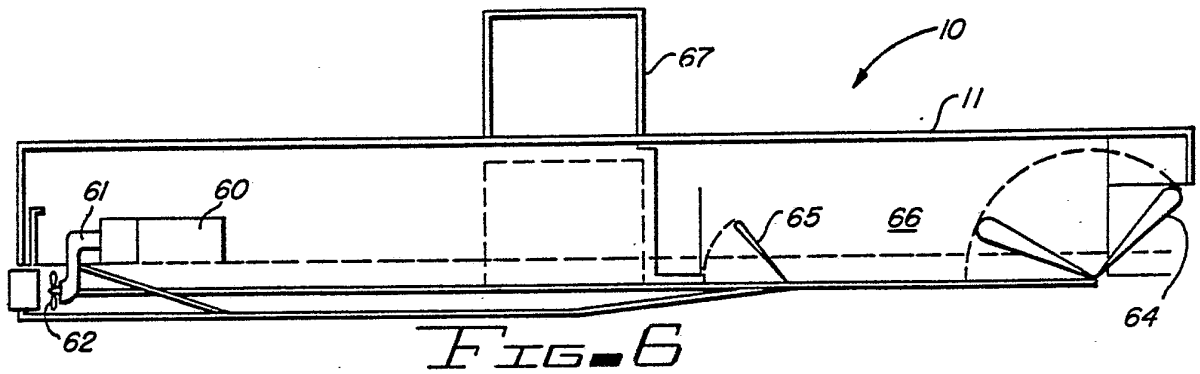
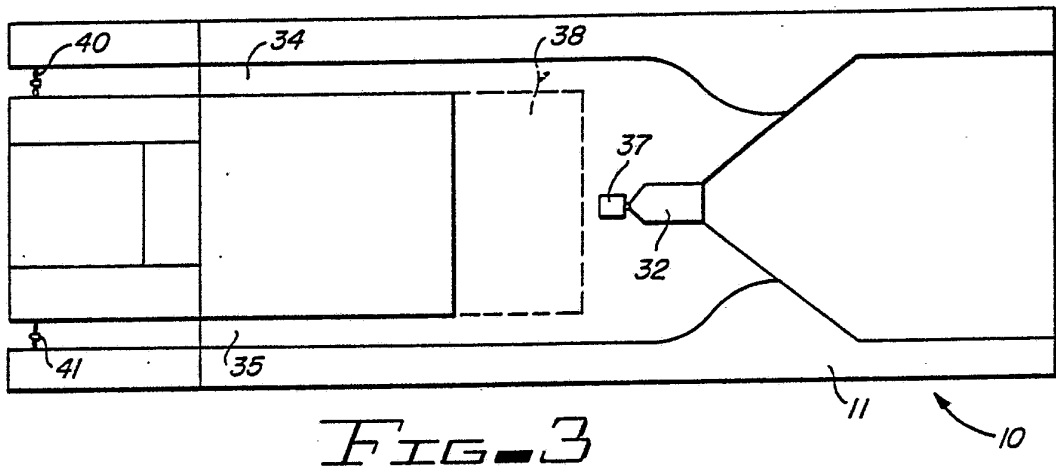
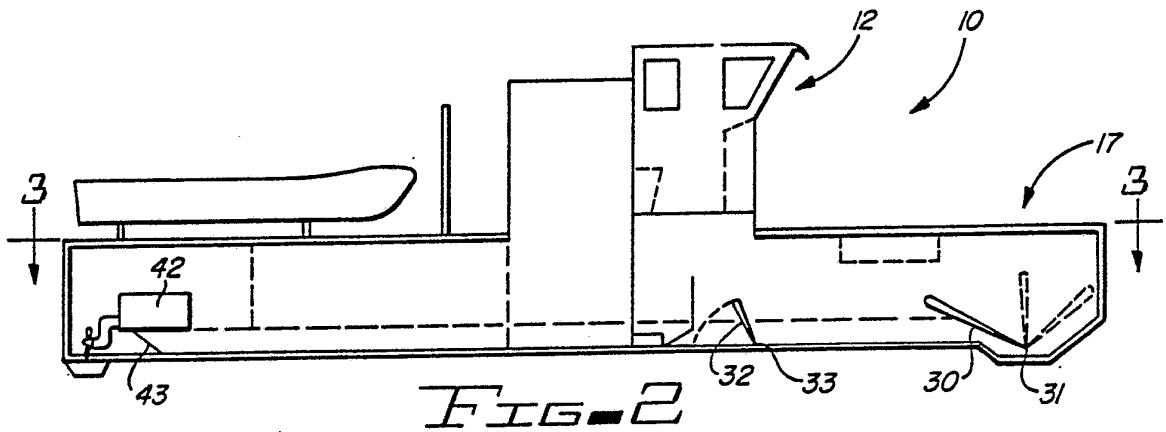

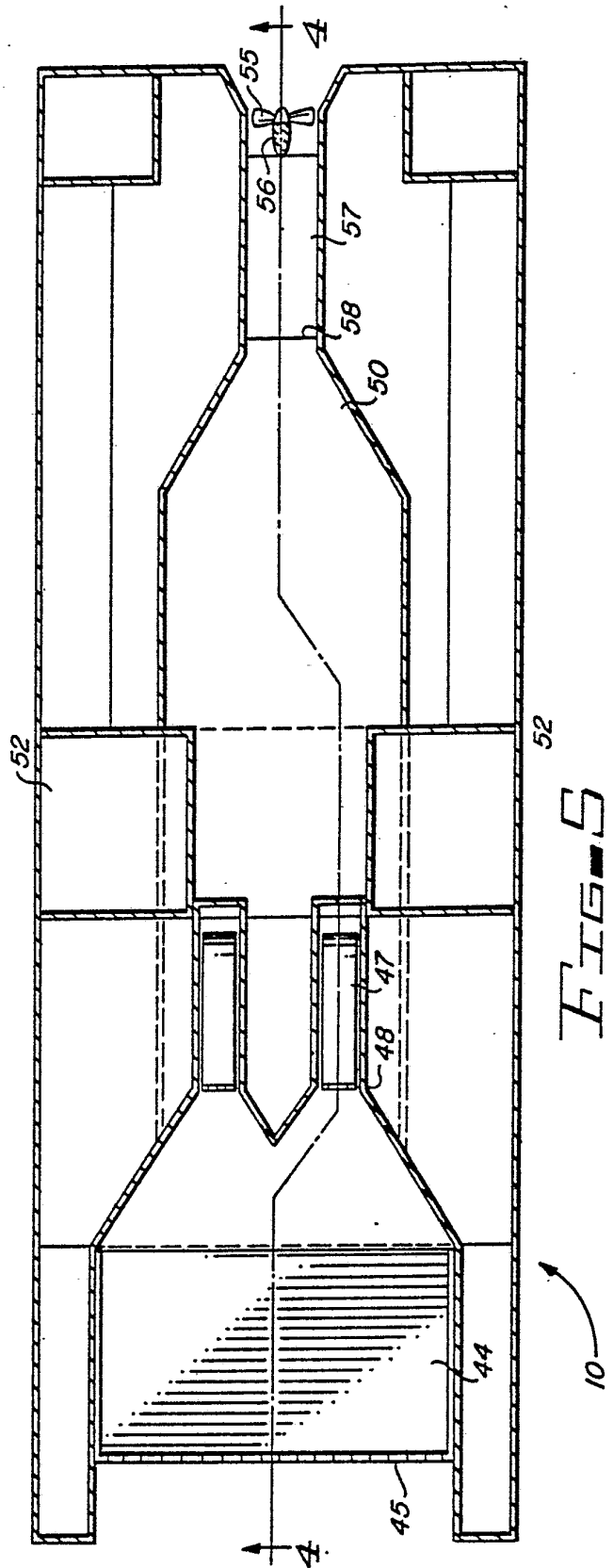
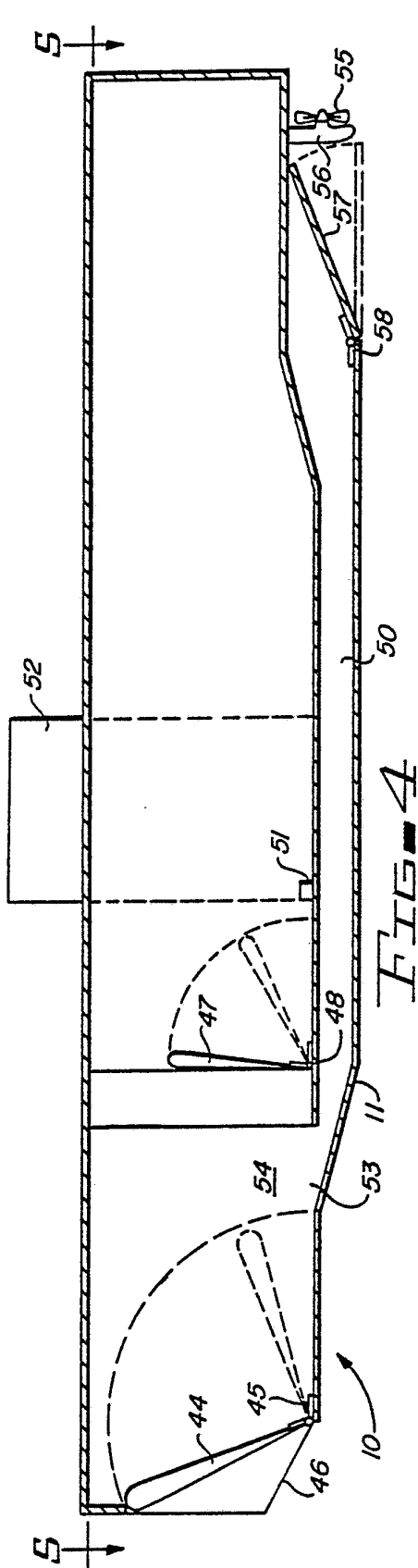

INTERNATIONAL PATENT OFFICE



FIG. 8

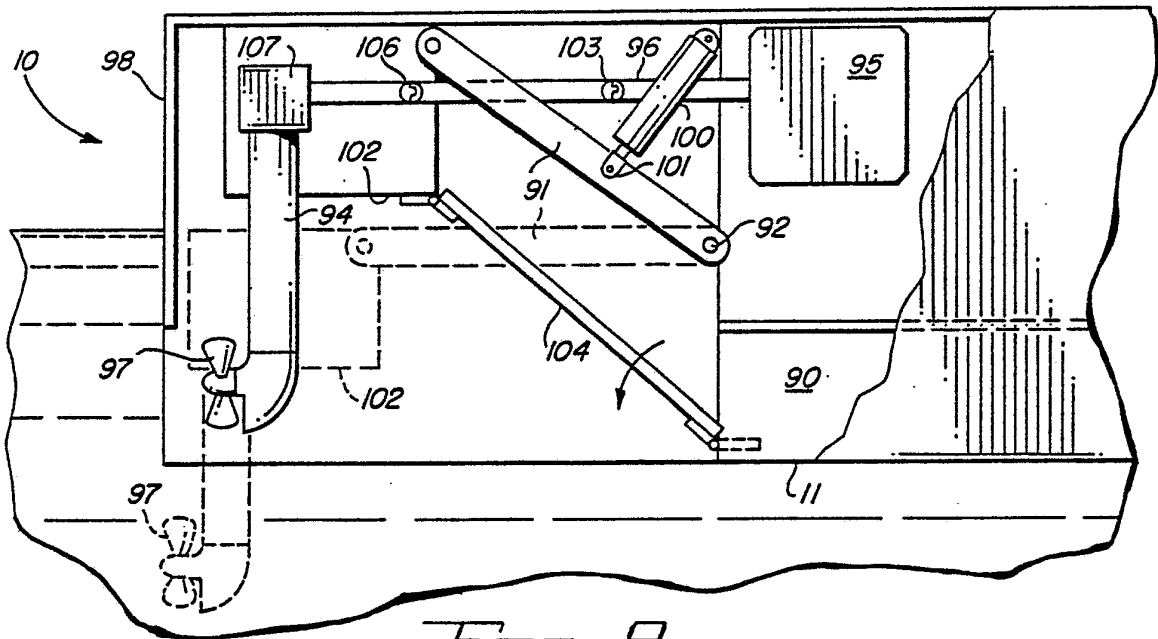
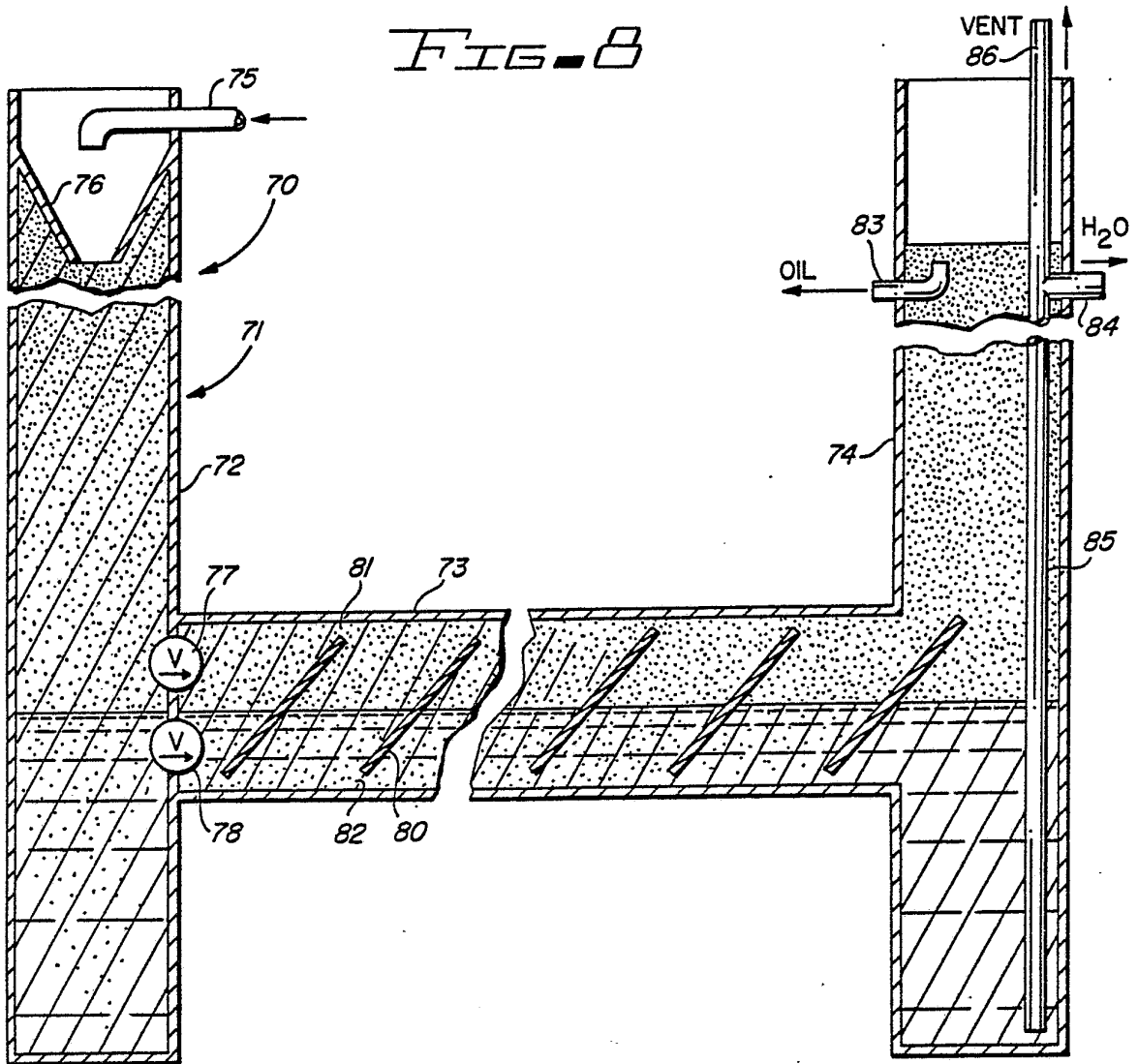

FIG. 9

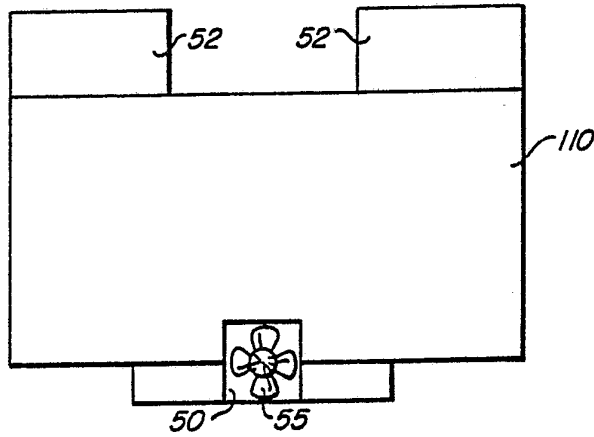

FIG. 10

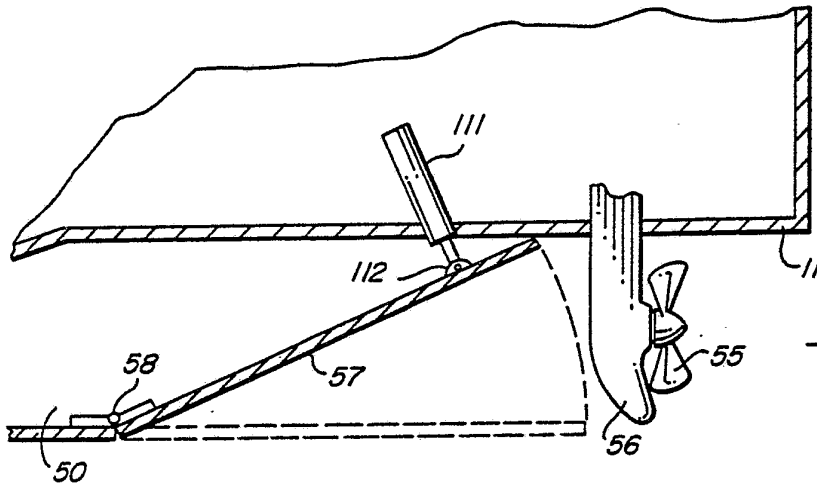

FIG. 11

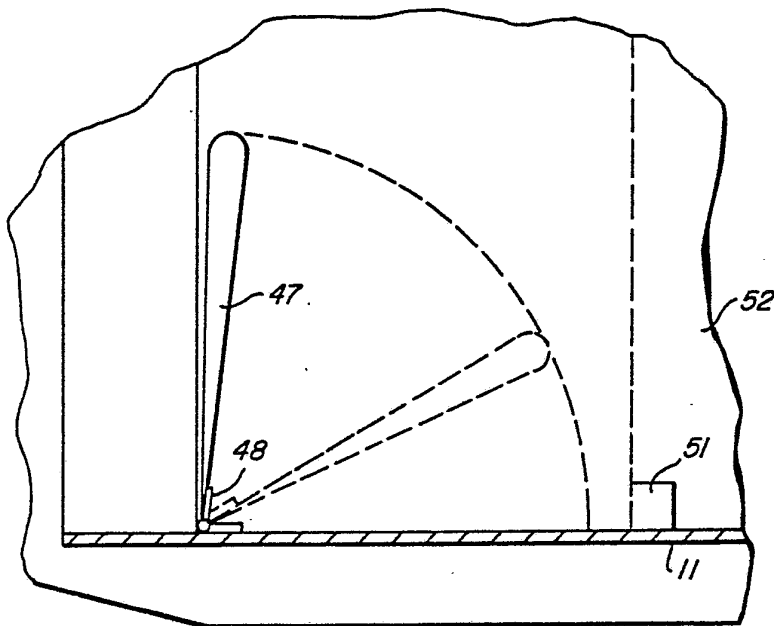
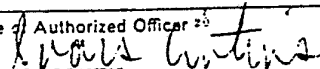

FIG. 12



INTERNATIONAL SEARCH REPORT

International Application No **PCT/US82/01433**

I. CLASSIFICATION OF SUBJECT MATTER (if several classification symbols apply, indicate all) ³		
According to International Patent Classification (IPC) or to both National Classification and IPC		
U.S. CL. ⁶ 210/242		
INT. CL. E02B 15/04		
II. FIELDS SEARCHED		
Minimum Documentation Searched ⁴		
Classification System	Classification Symbols	
U.S.	210/242, 242.3, 923, 521, 257, 515	
Documentation Searched other than Minimum Documentation to the extent that such Documents are Included in the Fields Searched ⁵		
III. DOCUMENTS CONSIDERED TO BE RELEVANT ¹⁴		
Category *	Citation of Document, ¹⁶ with indication, where appropriate, of the relevant passages ¹⁷	Relevant to Claim No. ¹⁸
X	US, A, 3,966,615, PUBLISHED 29 JUNE 1976, PETCHUL ET AL.	1,2,5
X	US, A, 3,860,519, PUBLISHED 14 JANUARY 1975, WEATHERFORD.	1,2,6-8,20
Y	US, A, 3,966,615, PUBLISHED 29 JUNE 1976, PETCHUL ET AL.	3,4,9-12
Y	US, A, 3,860,519, PUBLISHED 14 JANUARY 1975, WEATHERFORD.	10,13-19
Y	US, A, 3,844,944, PUBLISHED 29 OCTOBER 1974, MERCURI.	13-16,21-25
Y	US,A, 4,151,081, PUBLISHED 24 APR 1979, BOLLI ET AL.	12
A	US, A, 3,700,108, PUBLISHED 24 OCTOBER 1972, RICHARDS.	21-25
A E	US, A, 4,356,086, PUBLISHED 26 OCTOBER 1982, FILING DATE 04 SEPTEMBER 1980, OBERG.	21-25
A	US, A, 4,123,357, PUBLISHED 31 OCTOBER 1978, CLEMENTS ET AL.	21-25
<p>* Special categories of cited documents: ¹⁵</p> <p>"A" document defining the general state of the art which is not considered to be of particular relevance</p> <p>"E" earlier document but published on or after the international filing date</p> <p>"L" document which may throw doubts on priority claim(s) or which is cited to establish the publication date of another citation or other special reason (as specified)</p> <p>"O" document referring to an oral disclosure, use, exhibition or other means</p> <p>"P" document published prior to the international filing date but later than the priority date claimed</p> <p>"T" later document published after the international filing date or priority date and not in conflict with the application but cited to understand the principle or theory underlying the invention</p> <p>"X" document of particular relevance; the claimed invention cannot be considered novel or cannot be considered to involve an inventive step</p> <p>"Y" document of particular relevance; the claimed invention cannot be considered to involve an inventive step when the document is combined with one or more other such documents, such combination being obvious to a person skilled in the art.</p> <p>"&" document member of the same patent family</p>		
IV. CERTIFICATION		
Date of the Actual Completion of the International Search ²	Date of Mailing of this International Search Report ²	
06 CECEMBER 1982	23 DEC 1982	
International Searching Authority ¹	Signature of Authorized Officer ²⁰	
ISA/US	 SHARON COHEN	

A US, A, 4,045,344, PUBLISHED 30 AUGUST 1977,
YOTOTA.

21-25

V. OBSERVATIONS WHERE CERTAIN CLAIMS WERE FOUND UNSEARCHABLE ¹⁰

This international search report has not been established in respect of certain claims under Article 17(2) (a) for the following reasons:

1. Claim numbers because they relate to subject matter¹² not required to be searched by this Authority, namely:

2. Claim numbers because they relate to parts of the international application that do not comply with the prescribed requirements to such an extent that no meaningful international search can be carried out¹³, specifically:

VI. OBSERVATIONS WHERE UNITY OF INVENTION IS LACKING ¹¹

This International Searching Authority found multiple inventions in this international application as follows:

1. As all required additional search fees were timely paid by the applicant, this international search report covers all searchable claims of the international application.

2. As only some of the required additional search fees were timely paid by the applicant, this international search report covers only those claims of the international application for which fees were paid, specifically claims:

3. No required additional search fees were timely paid by the applicant. Consequently, this international search report is restricted to the invention first mentioned in the claims; it is covered by claim numbers:

4. As all searchable claims could be searched without effort justifying an additional fee, the International Searching Authority did not invite payment of any additional fee.

Remark on Protest

The additional search fees were accompanied by applicant's protest.

No protest accompanied the payment of additional search fees.