

May 25, 1965

H. A. GORSKE ETAL

3,185,896

IGNITION DEVICE

Filed Oct. 5, 1961

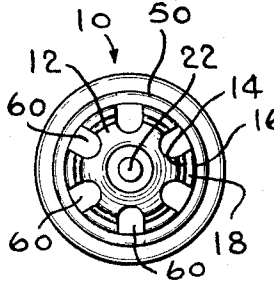
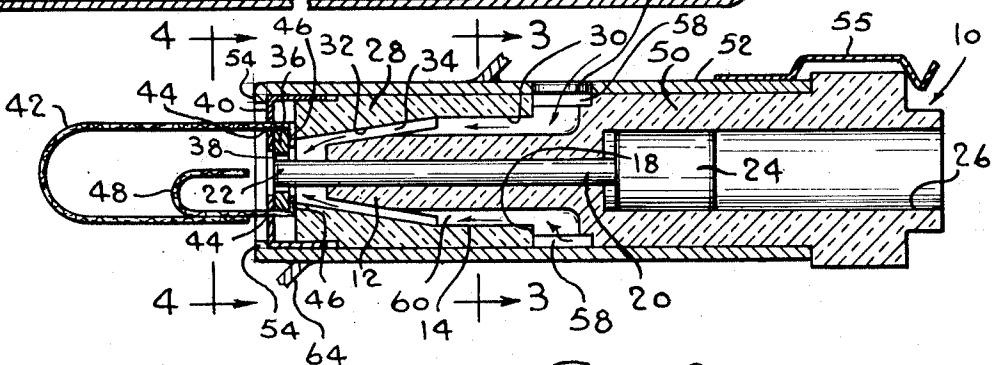
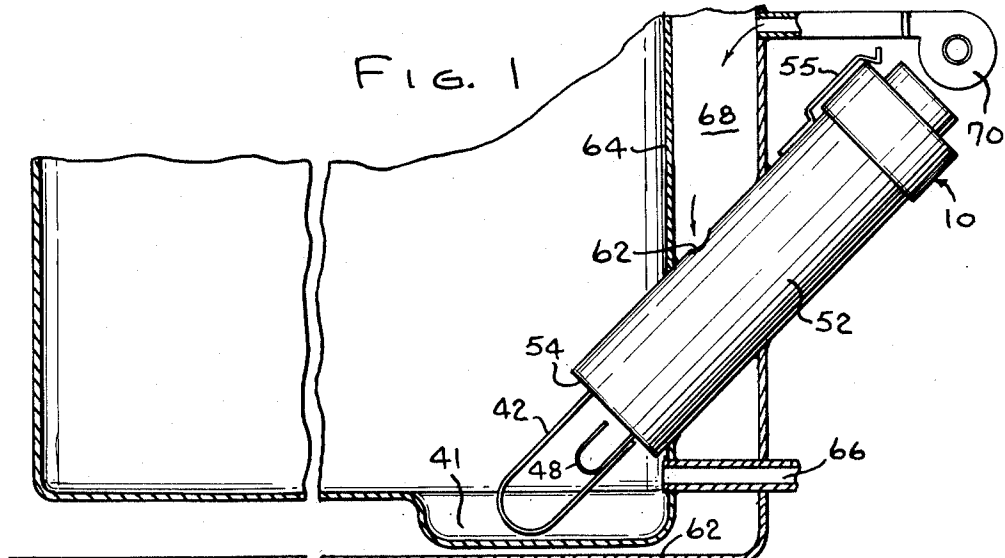

FIG. 3

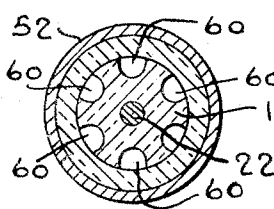

FIG. 4

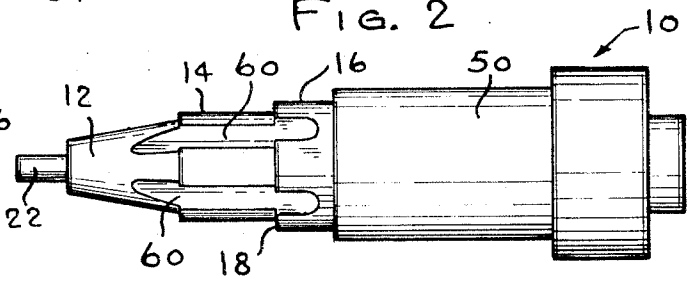

FIG. 5

INVENTORS
HERMAN A. GORSKE
LOURDES V. McCARTY

BY
Raymond H. Michael

ATTORNEY

1

3,185,896

IGNITION DEVICE

Herman A. Gorske and Lourdes V. McCarty, Milwaukee, Wis., assignors to Controls Company of America, Schiller Park, Ill., a corporation of Delaware
Filed Oct. 5, 1961, Ser. No. 143,135
10 Claims. (Cl. 317-88)

This invention relates to an electric ignition device for pot-type oil burners.

Maintaining a pilot flame in a pot-type oil burner for ignition purposes has been unsatisfactory in that the pilot flame is a source of soot which impairs efficiency. There have been prior attempts at providing electric ignition for pot-type burners, including spark ignition and glow elements of various types. However, during the combustion and ignition cycles carbon deposits on and builds up between the electrodes of the spark ignitor or tends to foul the glow elements or associated parts. In the case of a spark ignitor which is the type provided here, this build up of carbon is rapid and bridges the spark gap rendering the ignitor inoperative and requiring cleaning or replacement of the ignition device.

It is an object of this invention to provide a spark ignition device suitable for use in a pot-type oil burner.

Another object of this device is to provide a spark ignition device for a pot-type oil burner which will remain free of undesirable carbon deposits.

A further object of this invention is to provide a spark ignition device for a pot-type oil burner which will burn off any carbon deposits in the spark gap.

The novel features of this invention are set forth in the appended claims. The invention itself, together with additional objects and advantages thereof, will be more clearly understood from a reading of the following description in connection with the accompanying drawings wherein a preferred embodiment has been illustrated and in which:

FIG. 1 is a view of the spark ignition device as assembled in a pot-type oil burner;

FIG. 2 is a longitudinal section view of the ignition device;

FIG. 3 is a sectional view along lines 3-3 of FIG. 2; FIG. 4 is a sectional view along lines 4-4 of FIG. 2; FIG. 5 is a side view of the spark ignition device; and FIG. 6 is an end view thereof.

In a preferred embodiment of this invention the spark ignition device includes a body 10 composed of a suitable ceramic electrically insulating material and having a generally conical end portion 12 and stepped cylindrical portions 14 and 16 forming a shoulder 18. An elongated electrical conductor 20 extends axially through body 10 and has an end projecting from conical end 12 to form an electrode 22. An electrical terminal 24 is fixed to the other end of conductor 20 in a bore 26 in the body and can be electrically connected to a suitable source of electrical energy (not shown).

An air guide 28 engages shoulder 18 and surrounds conical end 12 of the body. The inner surface of guide 28 includes a generally conical surface 32 and a cylindrical surface 30 which engages cylindrical portion 14 of the body to maintain the guide 28 and surface 32 in spaced relation to form an annular, generally conical air passage 34 between end 12 and guide 28.

An annular electrode 36 is positioned on guide 28 in concentric relationship with electrode 22 to provide an

2

annular spark gap 38 therebetween and adjacent the end of air passage 34.

A cap 40 fits over the outer end of guide 28 to hold the electrode 36 in engagement with the guide. A wick member 42 extends through slots 44 in the cap and includes portions 46 disposed between electrode 36 and guide 28. The wick is adapted to be positioned in an oil pool or reservoir 41 (see FIG. 1) to draw oil up to the spark gap, and includes a portion 48 disposed adjacent the spark gap to insure oil delivery to and vaporization at the spark gap. Electrode 36 is preferably made of silicon carbide which, in addition to being an electrical conductor, also possesses good wicking properties so that it in effect forms an extension of the wick and insures the delivery of oil to the spark gap.

The assembly comprising body 10, electrode 20, guide 28, wick 42, electrode 36 and cap 40 is positioned within a metallic mounting sleeve 52. Mounting sleeve 52 is provided with an inwardly turned end 54 which is adapted to engage cap 40. The ignition device fits snugly within the sleeve with a cylindrical portion 50 of body 10 and guide 28, both of which have substantially equal outside diameters, engaging the sleeve. A spring 55 is suitably connected to mounting shell 52 and is positioned to engage body 10 to maintain the ignition device in assembled relationship with the sleeve.

Guide 28 abuts shoulder 18 and, when the ignition device is assembled within the mounting sleeve, an annular chamber 58 is formed between guide 28 and cylindrical portion 50. A plurality of grooves 60 extend axially of and are spaced peripherally around the body and connect chamber 58 to annular passage 34. Mounting sleeve 52 includes an aperture 62 which, when the ignition device is assembled in the sleeve, is in registry with air chamber 58 to provide ingress of air to that chamber.

In operation, sleeve 52 is attached to the wall 64 of a pot-type oil burner and is mounted adjacent the lower end of the oil burner where oil reservoir 41 is provided. A port 66 is provided to supply oil to reservoir 41 and the mounting sleeve is positioned so that wick 42 extends into the reservoir. Electrode 22 is connected to a suitable source of electrical power and electrode 36, through cap 40, mounting sleeve 52, and wall 64, is connected to ground to thereby complete an electrical circuit for the spark gap. Oil is drawn up to the spark gap where, when a spark arcs across the gap, it is ignited to initiate combustion within the burner. Preferably the ignition device of this invention is used in a forced draft oil burner wherein the pot of the burner is positioned within a chamber 68 (only a portion of which is shown in FIG. 1) which has associated therewith a source of air such as a blower 70. In such an oil burner, the air in chamber 68 is maintained at a positive pressure and will provide a forced air flow through the ignition device. More particularly, air is forced through opening 62 into chamber 58 then passes through grooves 60 to annular passage 34 and is discharged through the spark gap. Hence means is provided for directing a forced draft of air through the ignition device. In addition, combustion within the burner causes air to rise producing an aspirator effect at the spark gap which assists the air flow by drawing air through the ignition device. It should be noted that, although inclusion of means for providing forced air flow is preferred, it is not intended that this invention be so limited for in many applications the aspirator effect alone is sufficient and, further, improved materials may be

developed which will reduce the tendency to produce carbon such that the aspirator effect alone will be sufficient in all applications. Thus a continuous flow of air through the spark gap is provided so that carbon which deposits on the electrodes, when it has been heated to a combustible temperature by the spark, will burn-off to result in continuous removal of carbon which deposits on the electrodes. It should also be noted that the discharge end of air passage 34 conforms to the configuration of spark gap 38 so that a stream of air is provided through the entire spark gap.

The discussion of this invention with relation to a particular preferred embodiment thereof, has been intended for illustrative purposes only and should not be taken by way of limitation. Accordingly, it is intended in the appended claims to cover all modifications and embodiments of this invention as fall within the true spirit and scope thereof.

What we claim is:

1. A spark ignition device for use in a pot-type oil burner comprising, in combination, an elongated body having a generally conical end and a plurality of longitudinally extending peripherally spaced grooves, a first electrode supported from said conical end, a first member disposed in surrounding relationship with said body adjacent said conical end, an annular electrode supported on said first member in spaced surrounding relationship from said first electrode and forming a spark gap therewith, said first member including a generally conical inner wall disposed in spaced relation from said conical end of said body and forming therewith a conical passage extending between said grooves and said spark gap, means supported on said first member for engaging said annular electrode and urging said annular electrode into engagement with said first member, a wick extending from said spark ignition device and having a portion disposed between said annular electrode and said first member, and a sleeve member disposed in surrounding relationship with said body and engaging said first member to clamp said annular electrode on said first member with said portion of said wick therebetween, said sleeve including an aperture opening into said grooves for ingress of air so that air passes through said grooves and said conical passage and is discharged through said spark gap.

2. The combination of claim 1 including means connected between said body and said sleeve for clamping said sleeve on said body.

3. The combination of claim 1 wherein said annular electrode is made of silicon carbide.

4. A spark ignition device for use in a pot-type oil burner comprising, in combination, an elongated body having a generally conical end and a plurality of longitudinally extending peripherally spaced grooves, a first electrode supported from said conical end, a first member disposed in surrounding relation to said body adjacent said conical end, an annular electrode supported on said first member in spaced relationship from said first electrode and forming a spark gap therewith, said first member including a generally conical inner wall disposed in spaced relation from said conical end of said body and forming therewith a conical passage extending between said grooves and said spark gap, means supported on said first member for engaging said annular electrode and urging said annular electrode into engagement with said first member, a mounting sleeve member in engagement with said body and including an aperture opening into said grooves for ingress of air so that air passes through said grooves and said conical passage for discharge through said spark gap, and wick means for supplying fuel to said spark gap.

5. A spark ignition device comprising, in combination, a generally cylindrical body having an end portion and a grooved portion including a plurality of axially extending, circumferentially spaced grooves each extending away from said end portion and terminating intermediate the

ends of said body, a first electrode projecting from said end portion, means cooperating with said grooves to define restricted air passages from the termination of said grooves through said grooves to a point adjacent said first electrode and including a hollow member having a generally cylindrical interior engaging said body at said grooved portion and extending from a point adjacent said first electrode in a direction away from said first electrode over said grooves and terminating intermediate said body end portion and said groove termination, a second electrode supported on said first member at said point adjacent said first electrode and disposed in spaced relation from said first electrode so that said first and second electrodes define a spark gap through which air is discharged directly by said restricted air passages, and wick means for supplying fuel to the spark gap.

6. A spark ignition device comprising, in combination, a generally elongated body having an end portion and a grooved portion including a plurality of longitudinally extending, peripherally spaced grooves each extending away from said end portion, a first electrode projecting from said end portion, means extending from a point adjacent said first electrode in a direction away from said first electrode over said grooves and terminating in spaced relation from the termination of said grooves to define restricted air passages from said groove terminations and through said grooves to a point adjacent said first electrode, a second electrode supported on said means at said point adjacent said first electrode and in spaced relation from said first electrode so that said first and second electrodes define a spark gap through which air is discharged directly by said restricted air passages, and wick means for supplying fuel to the spark gap.

7. The spark ignition of claim 6 wherein said wick means engages one of said electrodes and said one electrode is made of silicon carbide to function as an extension of said wick means in supplying fuel to said spark gap.

8. A spark ignition device for use in a pot-type oil burner comprising, in combination, an elongated body having a generally conical end and a plurality of longitudinally extending peripherally spaced grooves, a first electrode supported from said conical end, means disposed in surrounding relation to said body adjacent said conical end, an annular electrode supported on said means in spaced relationship from said first electrode and forming a spark gap therewith, said means defining a generally conical wall in spaced relation from said conical end of said body and forming therewith a conical passage extending between said grooves and said spark gap, a mounting sleeve member engaging and fitting over said body and including an aperture opening into said grooves for ingress of air so that air passes through said grooves and said conical passage for discharge through said spark gap, and wick means for supplying fuel to said spark gap.

9. A spark ignition device for use in a pot-type oil burner comprising, in combination, an elongated body having an end portion and at least one groove extending away from said end portion, a first electrode supported from said end portion, means disposed in surrounding relationship with said body adjacent said end, an annular electrode supported on said first member in spaced surrounding relationship from said first electrode and forming a spark gap therewith, said means defining a wall disposed in spaced relation from said end portion of said body and forming therewith a generally annular passage extending between said groove and said spark gap, wick means extending from a point operatively adjacent said spark for supplying fuel to said spark gap, and a sleeve member engaging and fitting over said body and including an aperture opening into said groove for ingress of air so that air passes through said groove and said passage and is discharged through said spark gap.

10. The combination of claim 6 wherein said second electrode is generally annular and is arranged in spaced surrounding relationship with said first electrode to define

5

a generally annular spark gap through which air from said restricted air passages is discharged.

References Cited by the Examiner

UNITED STATES PATENTS

1,765,633	6/30	Stevenson	317—88
2,194,081	3/40	Bock	158—28
2,395,614	2/46	Csepely	158—28
2,431,456	11/47	Bock	158—28

5

2,493,662
2,526,169
2,645,082
2,646,486
2,693,082
2,701,324
2,741,716
3,071,182

6

1/50	Fitzpatrick	317—88
10/50	Steeg	158—28
7/53	Sarto	158—28
7/53	Udale	200—166
11/54	Arthur	158—28
2/55	Peroutky et al.	158—28
4/56	Arthur et al.	317—83 X
1/63	Delano	158—28

RICHARD M. WOOD, Primary Examiner.