



- (51) **International Patent Classification:**
B65D 41/04 (2006.01) *B65D 1/02* (2006.01)
- (21) **International Application Number:**
PCT/US2014/023370
- (22) **International Filing Date:**
11 March 2014 (11.03.2014)
- (25) **Filing Language:** English
- (26) **Publication Language:** English
- (30) **Priority Data:**
13/834,431 15 March 2013 (15.03.2013) US
- (71) **Applicant: AMCOR LIMITED** [AU/AU]; 109 Burwood Road, Hawthorn, Victoria 3122 (AU).
- (72) **Inventors; and**
- (71) **Applicants (for US only):** **BATES, Peter** [US/US]; 4807 Cottonwood Lane, Chelsea, Michigan 48118 (US). **WILSON, Bradley** [US/US]; 8811 Schellenberger Road, Manchester, Michigan 48158 (US). **STEIH, Richard** [US/US]; 7641 Napoleon Road, Jackson, Michigan 49201 (US). **MAST, Luke A.** [US/US]; 11999 Swan View Drive, Brooklyn, Michigan 49230 (US).
- (74) **Agents: ERJAVAC, Stanley M.** et al.; Harness, Dickey & Pierce, P.l.c., P.O. Box 828, Bloomfield Hills, Michigan 48303 (US).
- (81) **Designated States (unless otherwise indicated, for every kind of national protection available):** AE, AG, AL, AM,

AO, AT, AU, AZ, BA, BB, BG, BH, BN, BR, BW, BY, BZ, CA, CH, CL, CN, CO, CR, CU, CZ, DE, DK, DM, DO, DZ, EC, EE, EG, ES, FI, GB, GD, GE, GH, GM, GT, HN, HR, HU, ID, IL, IN, IR, IS, JP, KE, KG, KN, KP, KR, KZ, LA, LC, LK, LR, LS, LT, LU, LY, MA, MD, ME, MG, MK, MN, MW, MX, MY, MZ, NA, NG, NI, NO, NZ, OM, PA, PE, PG, PH, PL, PT, QA, RO, RS, RU, RW, SA, SC, SD, SE, SG, SK, SL, SM, ST, SV, SY, TH, TJ, TM, TN, TR, TT, TZ, UA, UG, US, UZ, VC, VN, ZA, ZM, ZW.

- (84) **Designated States (unless otherwise indicated, for every kind of regional protection available):** ARIPO (BW, GH, GM, KE, LR, LS, MW, MZ, NA, RW, SD, SL, SZ, TZ, UG, ZM, ZW), Eurasian (AM, AZ, BY, KG, KZ, RU, TJ, TM), European (AL, AT, BE, BG, CH, CY, CZ, DE, DK, EE, ES, FI, FR, GB, GR, HR, HU, IE, IS, IT, LT, LU, LV, MC, MK, MT, NL, NO, PL, PT, RO, RS, SE, SI, SK, SM, TR), OAPI (BF, BJ, CF, CG, CL, CM, GA, GN, GQ, GW, KM, ML, MR, NE, SN, TD, TG).

Declarations under Rule 4.17:

- as to applicant's entitlement to apply for and be granted a patent (Rule 4.17(ii))
- as to the applicant's entitlement to claim the priority of the earlier application (Rule 4.17(iii))

Published:

- with international search report (Art. 21(3))

(54) **Title:** CONTAINER FINISH FOR METAL LUG CLOSURE

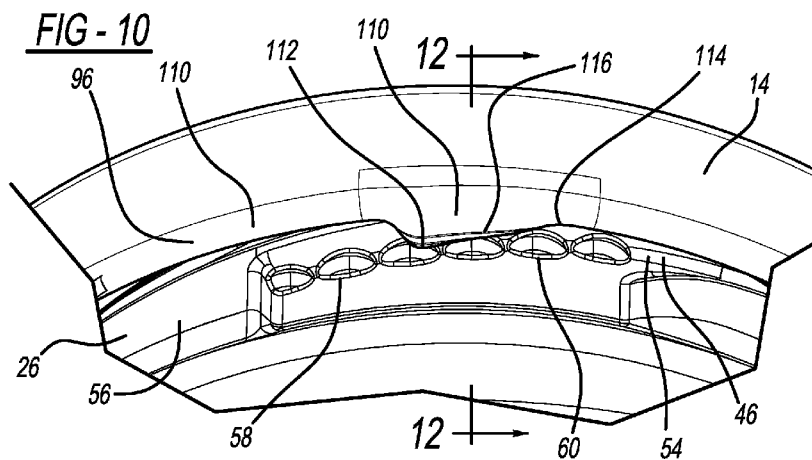

(57) **Abstract:** A container assembly including a container and a closure. The container includes a polymeric body and a polymeric finish. The polymeric finish includes a plurality of threads. The closure includes a plurality of metallic lugs configured to cooperate with the plurality of threads to couple the closure to the polymeric finish.



CONTAINER FINISH FOR METAL LUG CLOSURE

FIELD

[0001] The present disclosure relates to a container, and more specifically to a polymeric container with a metal lug closure.

BACKGROUND

[0002] This section provides background information related to the present disclosure, which is not necessarily prior art.

[0003] As a result of environmental and other concerns, plastic containers (more specifically polyester containers, such as polyethylene terephthalate (PET) containers for example) are now being used more than ever to package various commodities previously supplied in glass containers. Manufacturers and fillers, as well as consumers, have recognized that PET containers are lightweight, inexpensive, recyclable, and manufacturable in large quantities.

[0004] Blow-molded plastic containers have become commonplace in packaging numerous commodities. PET is a crystallizable polymer, meaning that it is available in an amorphous form or a semi-crystalline form. The ability of a PET container to maintain its material integrity relates to the percentage of the PET container in crystalline form, also known as the "crystallinity" of the PET container. The following equation defines the percentage of crystallinity as a volume fraction:

$$\% \text{ Crystallinity} = \left(\frac{\rho - \rho_a}{\rho_c - \rho_a} \right) \times 100$$

where ρ is the density of the PET material, ρ_a is the density of pure amorphous PET material (1.333 g/cc), and ρ_c is the density of pure crystalline material (1.455 g/cc). Once a container has been blown, a commodity may be filled into the container.

[0005] Various food products such as salsa, fruit and vegetable juices, nectars, etc. are often stored in glass containers, or in polymeric containers with a metal or polymeric closure, in order to increase their shelf life. To reduce costs and enhance the seal of the closure, for example, a cold-fill, hot-

fill or hot-fillable PET, warm-fill, or retort container suitable for pasteurization in the range of 50°F-250°F that can couple with a metal closure would be desirable.

5

SUMMARY

[0006] This section provides a general summary of the disclosure, and is not a comprehensive disclosure of its full scope or all of its features.

[0007] The present teachings provide for a 50°F-250°F filled container assembly including a container and a closure. The container includes a polymeric body and a polymeric finish. The polymeric finish includes a plurality of threads. The closure includes a plurality of metallic lugs configured to cooperate with the plurality of threads to couple the closure to the polymeric finish.

[0008] The present teachings further provide for a container including polymeric body and a polymeric finish. The polymeric finish includes a plurality of threads. A lug lock is associated with each one of the plurality of threads. A metallic closure includes metallic lugs configured to cooperate with the plurality of threads to couple the metallic closure to the polymeric finish.

[0009] The present teachings also provide for a container assembly including a container and a closure. The container includes a polymeric body and a polymeric finish. The polymeric finish includes a plurality of threads and a strengthening member associated with each one of the plurality of threads that extends from an exterior surface of the finish to provide the polymeric finish with an increased thickness. The closure includes a plurality of metallic lugs configured to cooperate with the plurality of threads to couple the metallic closure to the polymeric finish to provide an air-tight seal between the metallic closure and the polymeric finish. Each one of the plurality of metallic lugs includes a leading end and a trailing end, the leading end extends further towards a center of the closure than the trailing end.

[0010] Further areas of applicability will become apparent from the description provided herein. The description and specific examples in this summary are intended for purposes of illustration only and are not intended to limit the scope of the present disclosure.

DRAWINGS

[0011] The drawings described herein are for illustrative purposes only of selected embodiments and not all possible implementations, and are not intended to limit the scope of the present disclosure.

5 **[0012]** Figure 1 is a perspective view of a container assembly according to the present teachings including a container and a closure;

[0013] Figure 2 is a side view of a finish of the container of Figure 1;

10 **[0014]** Figure 3 is a cross-sectional view taken along line 3-3 of Figure 2;

[0015] Figure 4 is a side view of another container finish according to the present teachings;

[0016] Figure 5 is a cross-sectional view taken along line 5-5 of Figure 4;

15 **[0017]** Figure 6 is a perspective view of the closure of Figure 1;

[0018] Figure 7 is a plan view of an undersurface of the closure of Figure 1;

[0019] Figure 8 is a cross-sectional view taken along line 8-8 of Figure 7;

20 **[0020]** Figure 9 is a view of an inner sidewall surface of the closure taken in the direction of line 9-9 of Figure 7;

[0021] Figure 10 illustrates cooperation between the closure and the finish of Figure 1;

25 **[0022]** Figure 11 is a cross-sectional view that illustrates cooperation between the closure and the finish of Figure 1; and

[0023] Figure 12 is a cross-sectional view taken along line 12-12 of Figure 10.

[0024] Corresponding reference numerals indicate corresponding parts throughout the several views of the drawings.

30

DETAILED DESCRIPTION

[0025] Example embodiments will now be described more fully with reference to the accompanying drawings.

[0026] With initial reference to Figure 1, a container assembly according to the present teachings is illustrated at reference numeral 10. The container assembly 10 generally includes a container 12 and a closure 14, which is configured to couple with the container 12 as described herein. The container
5 12 can be made of any suitable material, such as a suitable polymer including polypropylene (PP), polyethylene terephthalate (PET), high-density polyethylene (HDPE), low-density polyethylene (LDPE), polyethylene naphthalate (PEN), a PET/PEN blend or copolymer, and various multilayer structures.

[0027] The container 12 can have any suitable size and shape and
10 can be configured to store any suitable liquid or solid therein, including any suitable food or condiment, such as salsa or sauce. The container 12 can be a hot-fill or hot-fillable container configured to receive hot-filled contents and suitable for pasteurization. The container 12 can be any suitable cold-fill, hot-fill, warm-fill or retort container suitable for pasteurization. The fill temperature
15 range can be from 50°F-250°F, such as at about 205°F for hot-fill.

[0028] Any suitable manufacturing method for the container 10 can be used, such as, for example, extrusion blow molding, injection blow molding, or one step injection stretch blow molding. The container 10 can have a finish
20 26 formed by injection molding, or a finish 26 formed in the blow mold and then trimmed (blow-trim). The finish 26 can be formed in any suitable manner, such as to have a crystalized finish in the range of about 25% to about 35%. Those having ordinary skill in the art will readily know and understand plastic container manufacturing method alternatives.

[0029] The closure 14 can be made of any suitable metallic
25 material, such as steel, tin, or aluminum. Because the closure 14 is made of metal, numerous advantages are realized. The metal closure 14 provides the container finish 26 with a 5-10% reduction in weight.

[0030] The container 12 generally includes a base 16 and a
30 sidewall 18 extending from the base 16. At an end of the sidewall 18 opposite to the base 16 is a shoulder 20 of the container 12. The shoulder 20 includes a rim 22, which can have an outer diameter greater than an outer diameter of the sidewall 18. Extending from the shoulder 20 is a neck 24, and extending from the neck 24 is the finish 26.

[0031] The sidewall 18 defines a first recess 28, which extends about an outer diameter of the sidewall 18. The first recess 28 is proximate to the rim 22. The sidewall 18 further defines a second recess 30 proximate to the base 16, and third and fourth recesses 32 and 34 between the first recess 28 and the second recess 30. The second, third and fourth recesses 30, 32 and 34 are generally circular and extend about the outer diameter of the sidewall 18.

[0032] A rib 36 can be included with the neck 24 between the shoulder 20 and the flange 42 to isolate the finish 26 from undesirable squeezing of the container 12 at the sidewall 18. The rib 36 can flex and absorb forces applied to the container 12, such as when the container 12 is squeezed, to prevent the finish 26 from being distorted and assuming, for example, an oval shape. The rib 36 can act as an active hinge to absorb movement in both the horizontal and vertical planes, such as by collapsing and/or expanding. The rib 36 can have any suitable shape or configuration to absorb movement in the horizontal and vertical planes. For example, the rib 36 can have a general V-shape as illustrated, a U-shape, a semi-circular shape, a half-round shape, a shape resembling a rectangular notch, or any suitable irregular shape. The shoulder 20 can slope away from the rib 36 at any suitable angle, such as at an angle of about 30° ($\pm 10^{\circ}$) relative to a horizontal line extending from the rib 36, as illustrated in Figure 2 at angle X_1 .

[0033] With continued reference to Figure 1 and additional reference to Figures 2 and 3, the finish 26 includes an upper lip 40 and a flange 42. The upper lip 40 is generally circular and defines an opening of the finish 26 and of the container 12 generally. The flange 42 is proximate to the neck 24, and thus the upper lip 40 and the flange 42 are at opposite ends of the finish 26. The flange 42 strengthens the finish 26 to help prevent undesirable ovalization of the finish 26. The flange 42 also prevents material from being blown into the rib 36 and the neck 24 during manufacture. The flange 42 also provides additional support during transfer, filling and capping of the container 12.

[0034] The finish 26 includes an exterior surface 44. A plurality of threads 46 extend about, and outward from, the exterior surface 44. Each thread 46 includes a first end or leading end 48 and a second end or trailing end 50. The leading end 48 is closer to the upper lip 40 than to the flange 42. The

trailing end 50 is closer to the flange 42 than the upper lip 40, or is generally equally distant between the upper lip 40 and the flange 42. Each thread 46 is thus generally angled and slopes downward toward the flange 42 from the leading end 48 to the trailing end 50. Each thread 46 further includes an upper surface 52 facing the upper lip 40 and an undersurface 54 generally facing the flange 42.

[0035] Any suitable number of threads 46 can be included at the finish 26. The number of threads 46 included will typically correspond to the number of lugs 110 (described herein) included with the closure 14. As illustrated, the finish 26 includes five threads 46, however, any suitable number of threads 46 can be included. The number of lugs 110 included with the closure 14 can depend on the size of the finish 26. For example, a 58mm finish 26 can include three or four lugs 110; a 63mm finish 26 can include four to six lugs 110; a 70mm finish 26 can include five to seven lugs 110; and an 82mm finish 26 can include five to nine lugs 110.

[0036] The finish 26 can further include a plurality of strengthening members 56. The strengthening members 56 are generally portions of the finish 26 that are thicker than surrounding portions of the finish 26. The strengthening members 56 extend or protrude outward from the exterior surface 44 to provide the finish 26 with a greater diameter at the strengthening members 56 than at areas of the finish 26 without the strengthening members 56. Any suitable number of strengthening members 56 can be included, and the strengthening members 56 can be provided at any suitable location about the finish 26. For example and as illustrated, a strengthening member 56 can be associated with each thread 46, such as at the trailing end 50 of each thread 46. The strengthening members 56 can be located at areas of the finish 26 where neighboring threads 46 overlap one another, such that the leading end 48 of one thread 46 overlaps a trailing end 50 of a neighboring thread 46. The strengthening members 56 can also act as thread stops to prevent over-tightening of the closure 14. More specifically, lugs 110 of the closure 14, which are described further herein, will contact the strengthening members 56 as the closure 14 is screwed onto the threads 46, and the lugs 110 will be stopped by the strengthening members 56 from moving further along the threads 46, thereby

preventing the closure 14 from being screwed tighter onto the threads 46 and the finish 26.

[0037] The strengthening members 56 can extend between the threads 46 and the flange 42, as illustrated in Figure 2 for example. The strengthening members 56 help prevent the finish 26 from being deformed, such as when the container 12 is squeezed. For example, the strengthening members 56 can help maintain the circular shape of the finish 26, and prevent the finish 26 from assuming an oval shape, such as when the container 12 is squeezed, which may break a seal between the closure 14 and the finish 26.

[0038] The finish 26 can further include a plurality of lug locks 58 to facilitate retention of the closure 14 to the finish 26. The lug locks 58 can be provided at any suitable location on the finish 26, such as at the undersurface 54 of each thread 46 as illustrated. The lug locks 58 can have any suitable configuration to retain a lug 110 of the closure 14 thereon, such as a plurality of ribs 60 extending along the undersurface 54 of each thread 46 between the leading and trailing ends 48 and 50 thereof. The ribs 60 provide a roughened surface that will help retain the lugs between two neighboring ribs 60 prevent the lugs 110 from sliding off of the threads 46.

[0039] With additional reference to Figures 4 and 5, the threads 46 can be configured as threads or grooves 46'. Threads 46' do not extend outward from the exterior surface 44 of the finish 26 as illustrated in Figures 1-3 with respect to threads 46. Instead, the threads 46' are defined by grooves 70 formed within the exterior surface 44 of the finish 26. Features of the threads 46' that are similar or identical to features of the threads 46 are referenced in the figures with the same reference numbers but with the prime (') symbol. Because the threads 46' are defined by the grooves 70, the exterior surface 44 acts as a strengthening member, and thus the strengthening members 56 described above need not be included. At the upper surfaces 52' of the threads 46', the finish 26 includes a reduced diameter portion 72, which has an outer diameter smaller than the exterior surface 44. The reduced diameter portion 72 can be considered part of the exterior surface 44.

[0040] With reference to Figures 6 and 7, the closure 14 of the container assembly 10 will now be described. The closure 14 includes a base

80, which includes an upper surface 82 and an undersurface 84. The base 80 is generally circular with an axis A extending through a center thereof. The center axis A extends through a flexible region 86 of the base 80, which can provide a seal indicator. The base 80 can include a seal member 88 proximate to the
5 sidewall 90. The seal member 88 can be generally circular, and can extend about the center axis A of the base 80. The seal member 88 mates with the upper lip 40 of the finish 26 as described herein to seal the closure 14 to the finish 26.

[0041] Extending from an outer diameter of the base 80 at the
10 undersurface 84 is a sidewall 90. The sidewall 90 includes an outer surface 92 and an inner surface 94, which is opposite to the outer surface 92. The sidewall 90 includes a rim 96 at an end of the sidewall 90 opposite to the base 80. The rim 96 is generally circular and extends about the center axis A of the base 80.

[0042] With continued reference to Figures 6 and 7, and additional
15 reference to Figure 8, the rim 96 includes an inner surface 98, an outer surface 100, and a side surface 102. The outer surface 100 is opposite to the inner surface 98. The rim 96 can be formed in any suitable manner, such as by a portion of the sidewall 90 that is curved or rolled inward towards the inner surface 98 of the sidewall 90.

[0043] The rim 96 includes a plurality of lugs 110. The lugs 110
20 can be evenly spaced apart along the rim 96, or arranged at any other suitable interval. Any suitable number of lugs 110 can be included, such as only five lugs 110, less than five lugs 110, or more than five lugs 110, such as six, seven, eight, or more lugs 110. Providing five or more lugs 110 results in numerous
25 advantages, such as distribution of forces exerted upon the finish 26 as a result of the container being squeezed, which can prevent the shape of the finish 26 from being distorted.

[0044] Each lug 110 includes a first end or leading end 112 and a
30 second end or trailing end 114. Extending between the leading end 112 and the trailing end 114 is an intermediate portion 116. Each lug 110 extends further from the sidewall 90 towards the center axis A at the leading end 112 than at the trailing end 114. Each lug 110 is angled and/or curved between the leading and trailing ends 112 and 114 corresponding to an angle and/or curve at which the

threads 46 extend about the finish 26 so that the lugs 110 will generally continuously mate with the threads 46 along substantially their entire length.

[0045] To couple the closure 14 to the finish 26, the lugs 110 are positioned at the threads 46 and the closure 14 is rotated such that the lugs 110 slide along the undersurface 54 of each thread 46. The lugs 110 are arranged such that they contact the undersurface 54 of each thread 46 along substantially the entire length of the lugs 110 between the leading end 112 and the trailing end 114, as illustrated in Figures 10 and 11. The lugs 110 are configured to cooperate with the threads 46' in a similar manner, because the threads 46' can be dimensioned proportionate to the threads 46 or be provided with the same dimensions as the threads 46.

[0046] The lugs 110 can be formed in any suitable manner to arrange portions of the side surface 102 of the rim 96 closer to the center axis A at the lugs 110, as compared to portions of the side surface 102 between the lugs 110. For example, any device suitable for pulling or generally moving the rim 96 towards the axial center A so that the leading end 112 of the lugs 110 extends further towards the center axis A than the trailing end 114 may be used.

[0047] Cooperation between the closure 14 and the finish 26 will now be described in further detail. To secure the closure 14 to the finish 26, the closure 14 is arranged such that the sidewall 90 extends about the exterior surface 44 of the finish 26 with the inner surface 94 of the sidewall 90 facing the exterior surface 44 of the finish 26. Each lug 110 is arranged at a different one of the threads 46 such that the leading end 112 of each lug 110 abuts the undersurface 54 of each leading end 48 of the threads 46. The closure 14 is then rotated to slide the lugs 110 along the undersurface 54 of the threads 46 and move the lugs 110 towards the trailing ends 50 of the threads 46. As the lugs 110 slide along the undersurface 54 of the threads 46, the lugs 110 will also slide against and over the ribs 60. When the leading end 112 is between two ribs 60, interaction between the leading end 112 and the ribs 60 on either side thereof will help prevent the lug 110 from sliding off the threads 46 due to increased interference, thus loosening the coupling of the closure 14 to the finish 26.

[0048] As the closure 14 is rotated and the lugs 110 move along the undersurface 54 of the threads 46, the base 80 of the closure 14 moves toward the upper lip 40 of the finish 26. The seal member 88 at the undersurface 84 of the base 80 contacts the upper lip 40 of the finish 26 to provide an airtight seal between the closure 14 and the finish 26. The closure 14 can be rotated until the seal 88 cannot be further depressed against the lip 40, or until the lugs 110 contact the strengthening members 56 at the trailing end 50 of the threads 46 such that the lugs 110 are generally centered on each thread 46, such as relative to the length of the upper surface 52 of each thread 46. The lugs 110 are provided with an increased length to enhance cooperation between the lugs 110 and the threads 46, and to more easily center the lugs 110 on the threads 46. For example a standard lug with an approximate length of 0.55" can be increased by about 30% to a new length of about 0.7". With respect to the configuration of threads 46' of Figure 4, the closure 14 can be tightened until the lugs 110 reach the end of the groove 70 associated with the threads 46' (Figure 4).

[0049] As illustrated in Figures 11 and 12 for example, each lug 110 contacts the thread 46 associated therewith at least at a first contact area 120, and contacts either the exterior surface 44 of the finish 26 (Figure 11) or the ribs 60 (Figure 12) at least at a second contact area 122. At the first contact area 120, contact occurs between the portion of the lugs 110 defined by the inner surface 98 of the rim 96 and the undersurface 54 of the threads 46. At the second contact area 122, there is contact between the portions of the lugs 110 defined by the side surface 102 of the rim 96 and the exterior surface 44 of the finish 26 (Figure 11) or the ribs 60 (Figure 12). A gap 124 may be defined between the first contact area 120 and the second contact area 122. The lugs 110 are angled and shaped to provide substantially continuous contact between the lugs 110 and the threads 46 to enhance fixation of the closure 14 to the finish 26. In some applications, one or more of the threads 46, such as thread 46' as illustrated in Figure 12, may extend to a distance suitable to contact the inner surface 94 of the closure 14.

[0050] The present teachings allow the height of the finish 26 to be reduced, such as between the threads 46 and the upper lip 40, and between the

threads 46 and the flange 42, thereby reducing the amount of material required for the finish 26, which conserves costs and reduces the overall weight of the container 12.

[0051] The foregoing description of the embodiments has been
5 provided for purposes of illustration and description. It is not intended to be
exhaustive or to limit the disclosure. Individual elements or features of a
particular embodiment are generally not limited to that particular embodiment,
but, where applicable, are interchangeable and can be used in a selected
embodiment, even if not specifically shown or described. The same may also be
10 varied in many ways. Such variations are not to be regarded as a departure from
the disclosure, and all such modifications are intended to be included within the
scope of the disclosure.

CLAIMS

What is claimed is:

- 5 1. A container assembly comprising:
a container including a polymeric body and a polymeric finish, the
polymeric finish including a plurality of threads; and
a closure including a plurality of metallic lugs configured to
cooperate with the plurality of threads to couple the closure to the polymeric
finish.
10
2. The container assembly of Claim 1, wherein the polymeric body
and polymeric finish include polyethylene terephthalate (PET).
- 15 3. The container assembly of Claim 1, wherein the polymeric finish is
one of a blow-trim or an injection thread finish.
- 20 4. The container assembly of Claim 1, wherein when the closure is
coupled to the container, each one of the plurality of metallic lugs is configured to
simultaneously contact one of the threads and an external surface of the finish.
- 25 5. The container assembly of Claim 1, wherein the polymeric finish
includes a plurality of strengthening members that extend from an exterior
surface of the finish and provide the finish with an increased thickness, one of
the plurality of strengthening members is associated with each one of the
plurality of threads, the strengthening members provide a stop for the metallic
lugs to prevent the metallic lugs from moving along the threads past the
strengthening members and center the metallic lugs along the threads with
respect to an upper surface of the threads.
- 30 6. The container assembly of Claim 5, a trailing end of each one of
the plurality of threads has one of the plurality of strengthening members integral
therewith.

7. The container assembly of Claim 1, further comprising a plurality of protruding lug locks at each one of the plurality of threads, wherein when the closure is coupled to the container, each one of the plurality of metallic lugs is configured to simultaneously contact one of the threads and at least one of the
5 lug locks.

8. The container assembly of Claim 7, wherein the plurality of lug locks are at an under surface of each one of the plurality of threads, and wherein each lug lock includes a plurality of ribs.
10

9. The container assembly of Claim 1, where the closure includes only five metallic lugs evenly spaced apart about the closure.

10. The container assembly of Claim 1, wherein the metallic lugs are
15 portions of a sidewall of the closure extending inward towards a center of the closure.

11. The container assembly of Claim 1, wherein each one of the plurality of metallic lugs includes a leading end and a trailing end, the leading
20 end extends further towards the center of the closure than the trailing end.

12. The container assembly of Claim 1, wherein each one of the plurality of metallic lugs extends at an angle between the leading end and the trailing end that generally matches an angle at which the plurality of threads
25 extend along the polymeric finish such that each lug is in contact with the thread associated therewith substantially along an entire length of each lug when the lugs are coupled to the threads.

13. The container assembly of Claim 1, wherein each one of the
30 plurality of metallic lugs is configured to simultaneously contact both of the plurality of threads and ribs of a lug lock.

14. The container assembly of Claim 1, wherein the polymeric finish is a blow-trim finish with a crystallinity of from about 25% to about 35%.

5 15. The container assembly of Claim 1, wherein the container includes a shoulder extending from a rib of a neck of the container at an angle of from about 20° to about 40°.

10 16. The container assembly of Claim 1, wherein the container includes a shoulder extending from a rib of a neck of the container at an angle of about 30°.

17. A container assembly comprising:
a container including a polymeric body and a polymeric finish, the polymeric finish including a plurality of threads;
15 a lug lock associated with each one of the plurality of threads; and
a metallic closure including at least five metallic lugs configured to cooperate with the plurality of threads to couple the metallic closure to the polymeric finish.

20 18. The container of Claim 17, wherein the lug lock includes a plurality of ribs at an undersurface of each one of the plurality of threads; and wherein when the metallic closure is coupled to the container, each one of the metallic lugs is configured to simultaneously contact one of the threads and at least one of the lug locks.

25 19. The container of Claim 17, wherein the polymeric finish is one of a blow-trim or an injection thread finish.

30 20. The container of Claim 17, wherein the polymeric finish includes a plurality of strengthening members that extend from an exterior surface of the finish, one of the plurality of strengthening members is integral with a trailing end of each one of the plurality of threads, the strengthening members provide a stop for the metallic lugs to prevent the metallic lugs from moving along the threads

past the strengthening members and center the metallic lugs along the threads with respect to an upper surface of the threads.

21. A container assembly comprising:

5 a container including a polymeric body and a polymeric finish, the polymeric finish including a plurality of threads and a strengthening member associated with each one of the plurality of threads that extends from an exterior surface of the polymeric finish to provide the polymeric finish with an increased thickness; and

10 a closure including a plurality of metallic lugs configured to cooperate with the plurality of threads to couple the metallic closure to the polymeric finish to provide an air-tight seal between the metallic closure and the polymeric finish, each one of the plurality of metallic lugs includes a leading end and a trailing end, the leading end extends further towards a center of the
15 closure than the trailing end.

22. The container assembly of Claim 21, further comprising an isolation rib between a flange of the polymeric finish and a shoulder of the
20 container assembly.

23. The container assembly of Claim 21, further comprising a plurality of lug retention ribs at an undersurface of each one of the plurality of threads, wherein the polymeric finish is one of a blow-trim or an injection thread finish.

25 24. The container assembly of Claim 21, wherein the container includes a shoulder extending from a rib of a neck of the container at an angle of from about 20° to about 40°.

30 25. The container assembly of Claim 21, wherein the container includes a shoulder extending from a rib of a neck of the container at an angle of about 30°.

26. The container assembly of Claim 21, wherein an inner surface of the closure is configured to contact at least one of the plurality of threads when the closure is coupled to the container.

5 27. The container assembly of Claim 21, wherein at least one of the plurality of threads extends a distance from the polymeric finish sufficient to contact an inner surface of the closure when the closure is coupled to the threads.

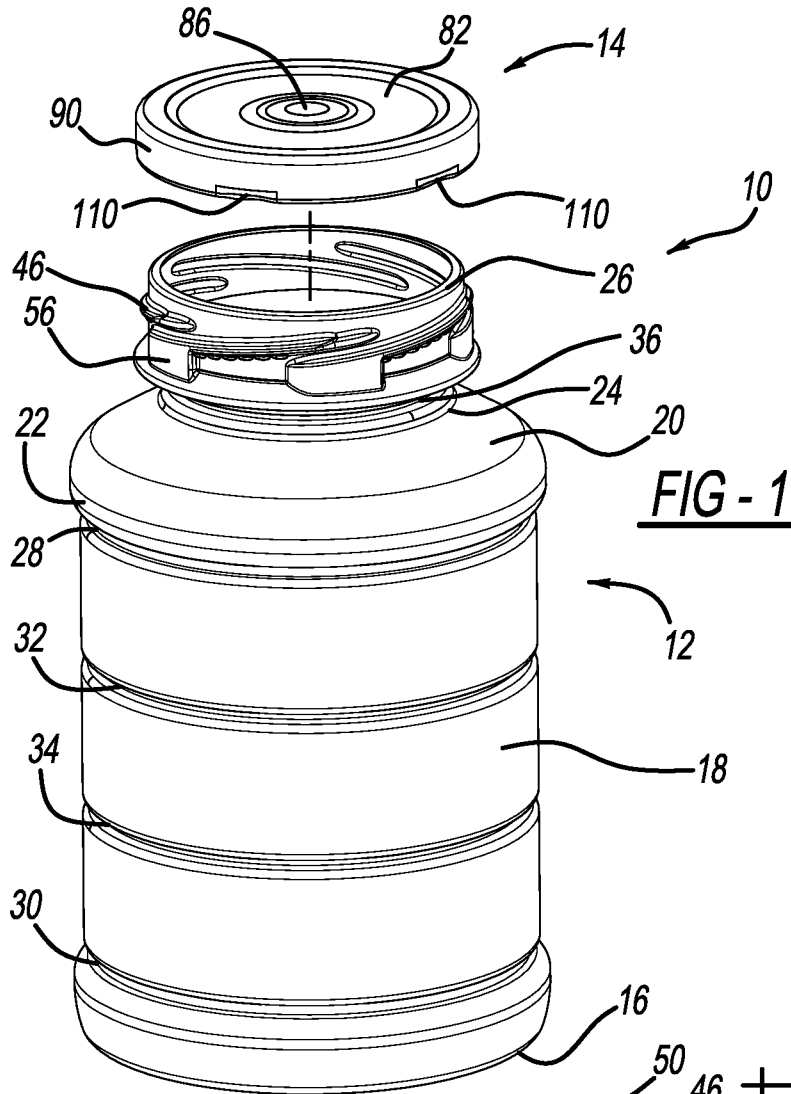

FIG - 1

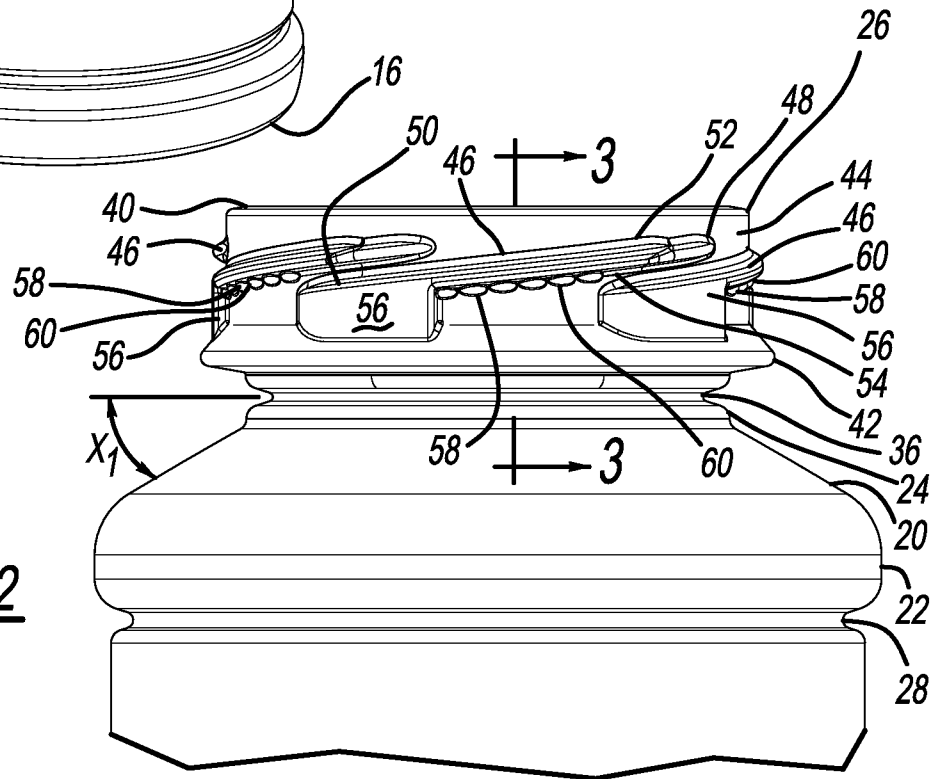

FIG - 2

FIG - 3

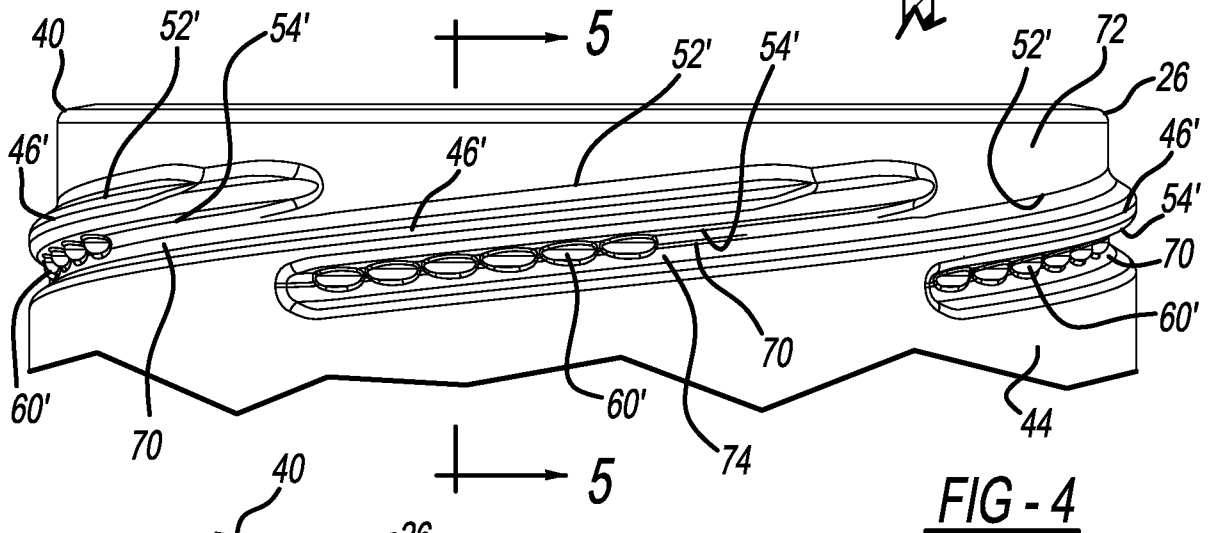
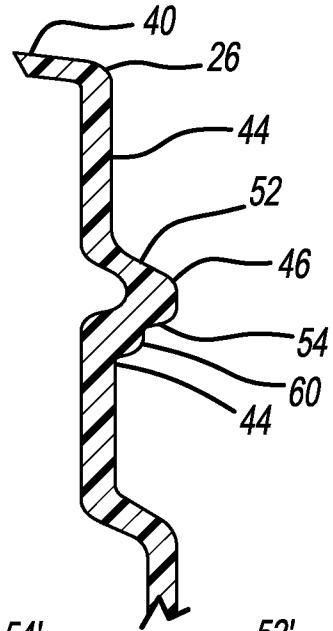
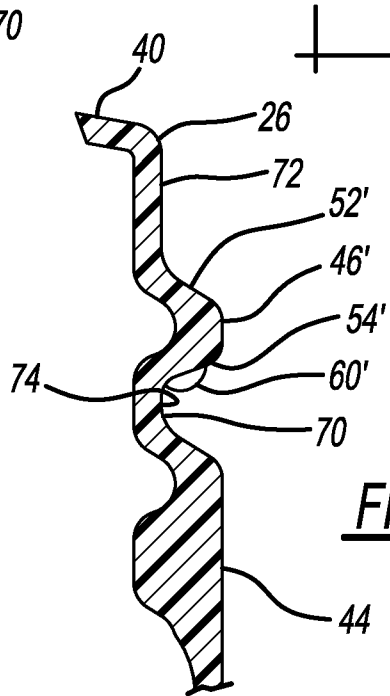
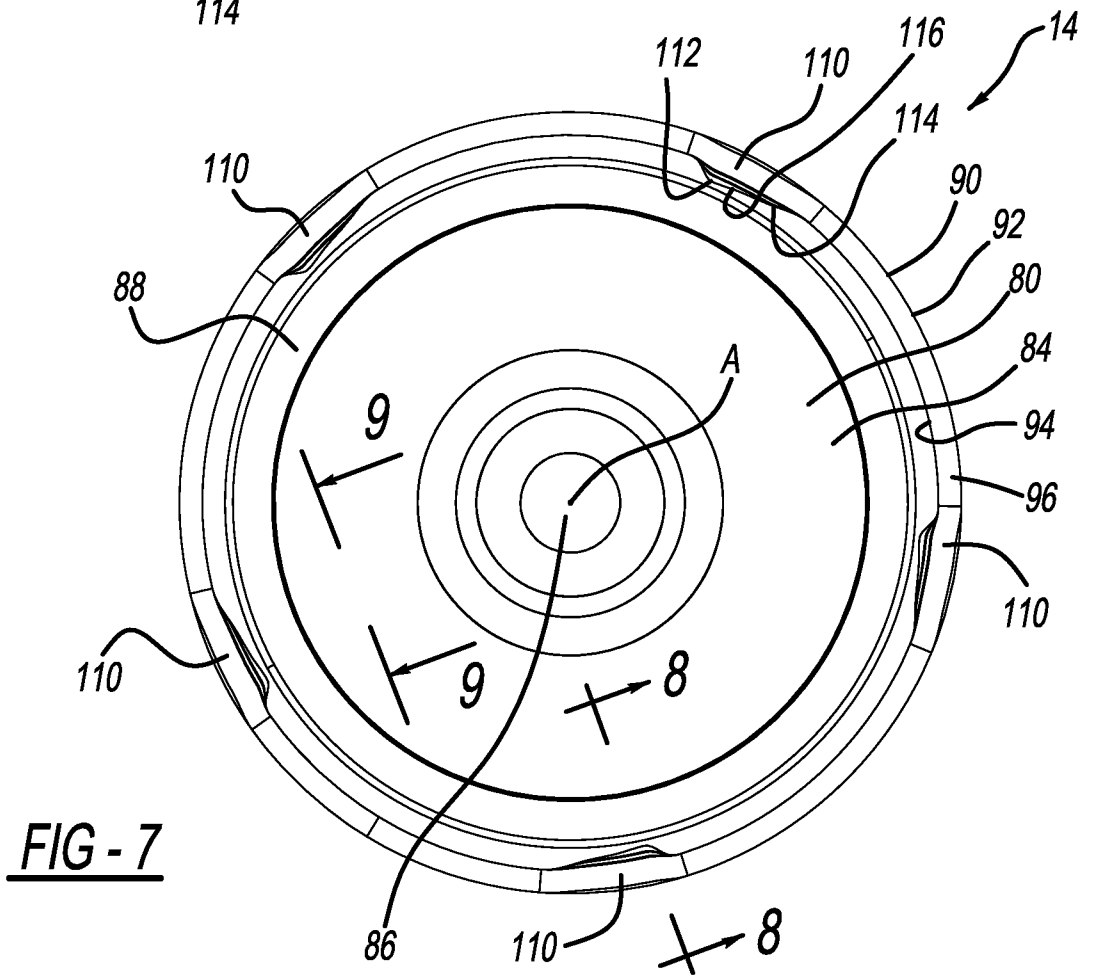
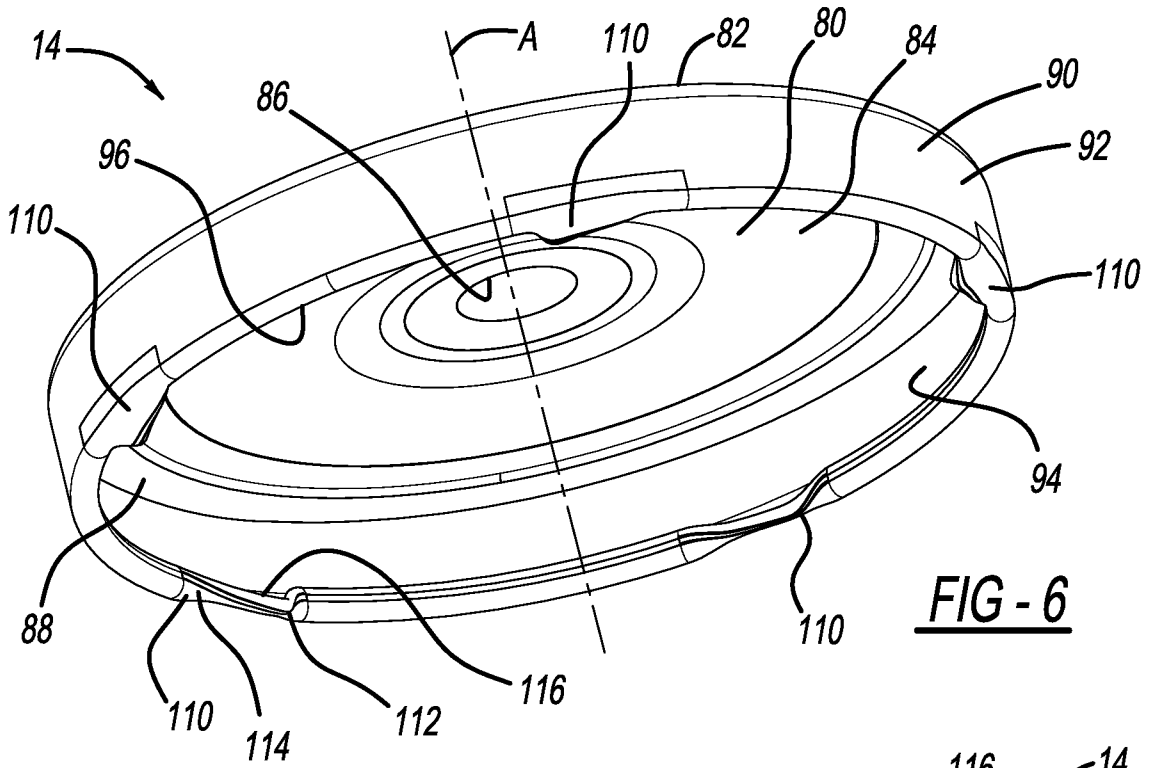
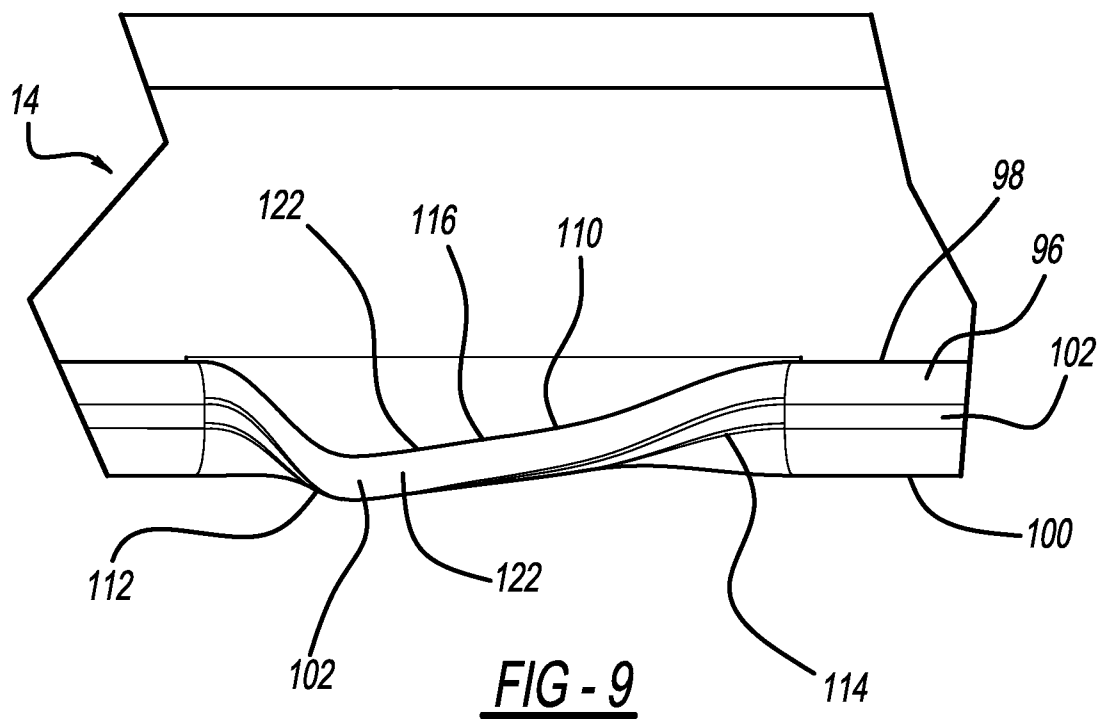
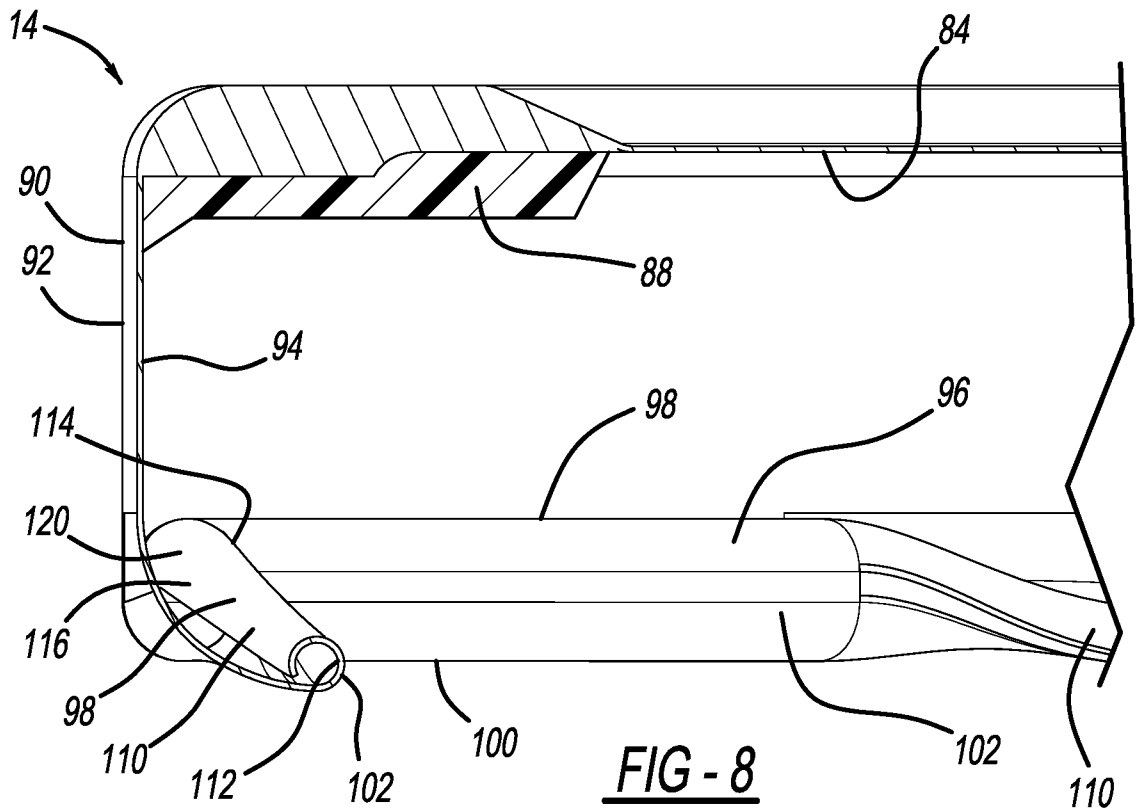

FIG - 4

FIG - 5







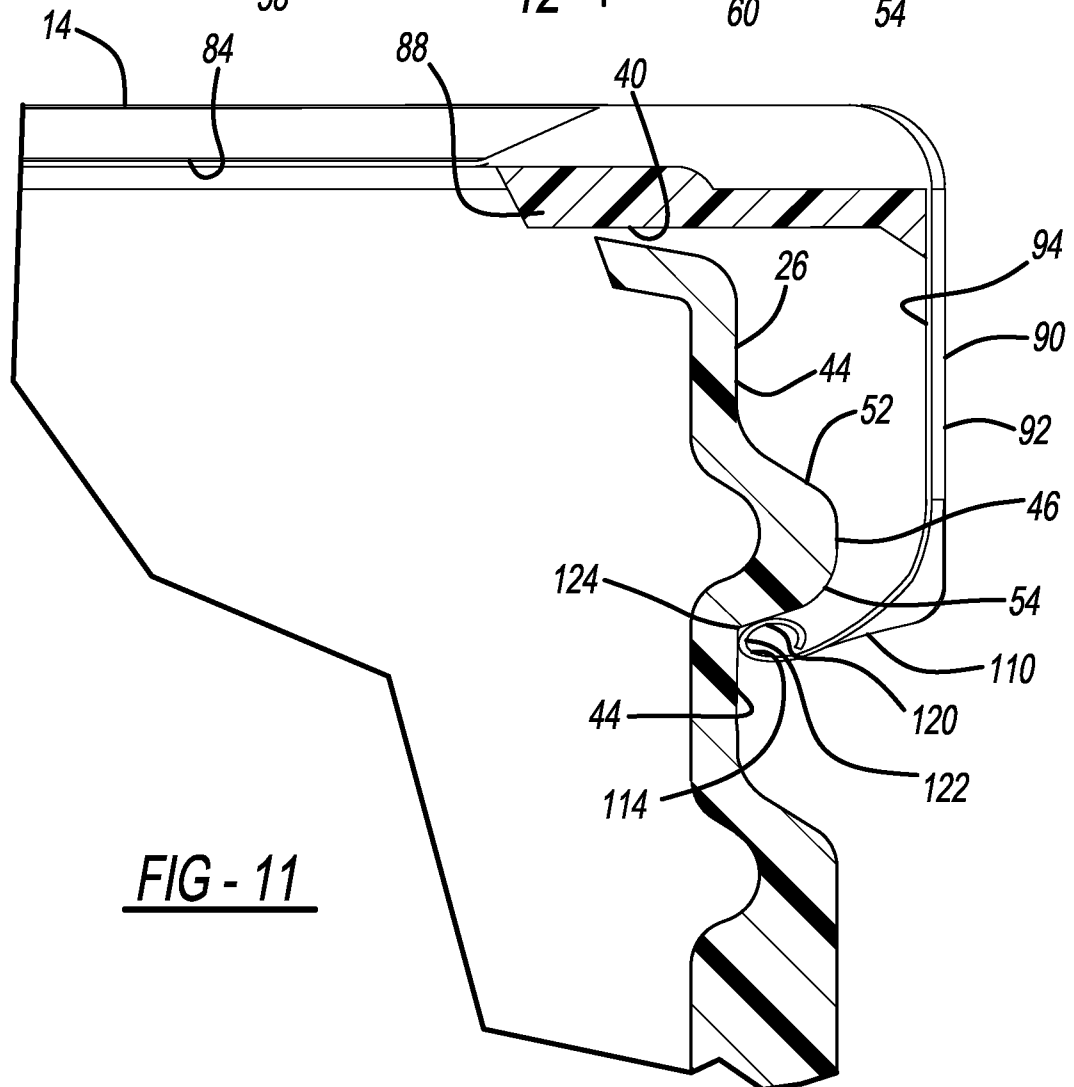
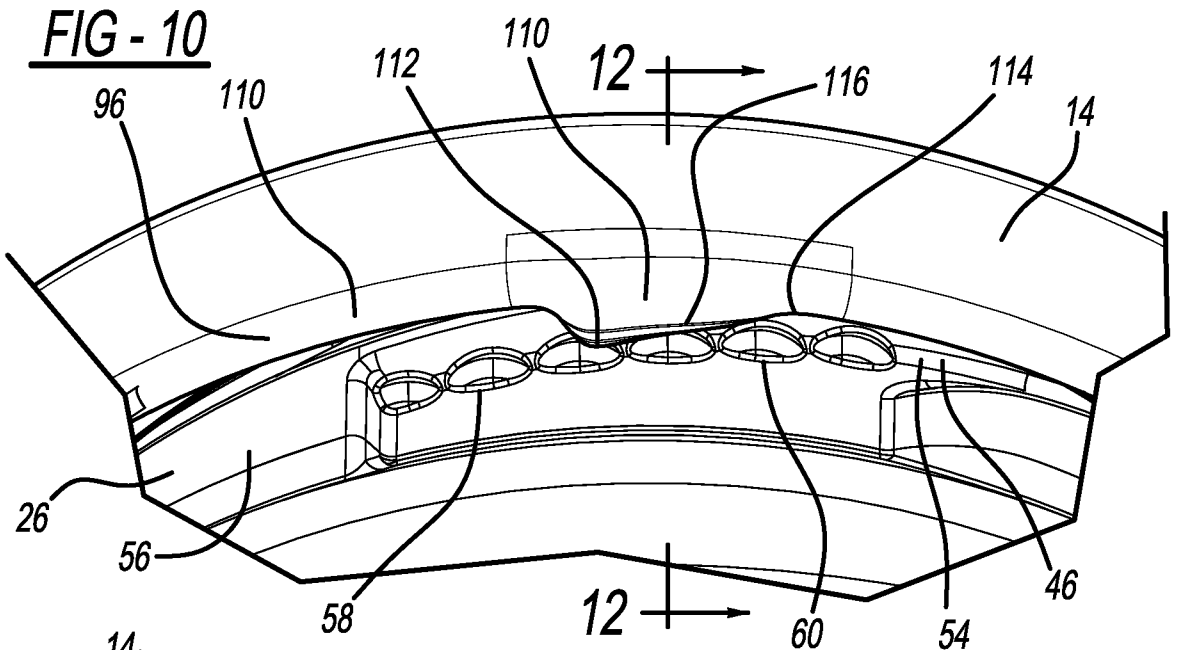

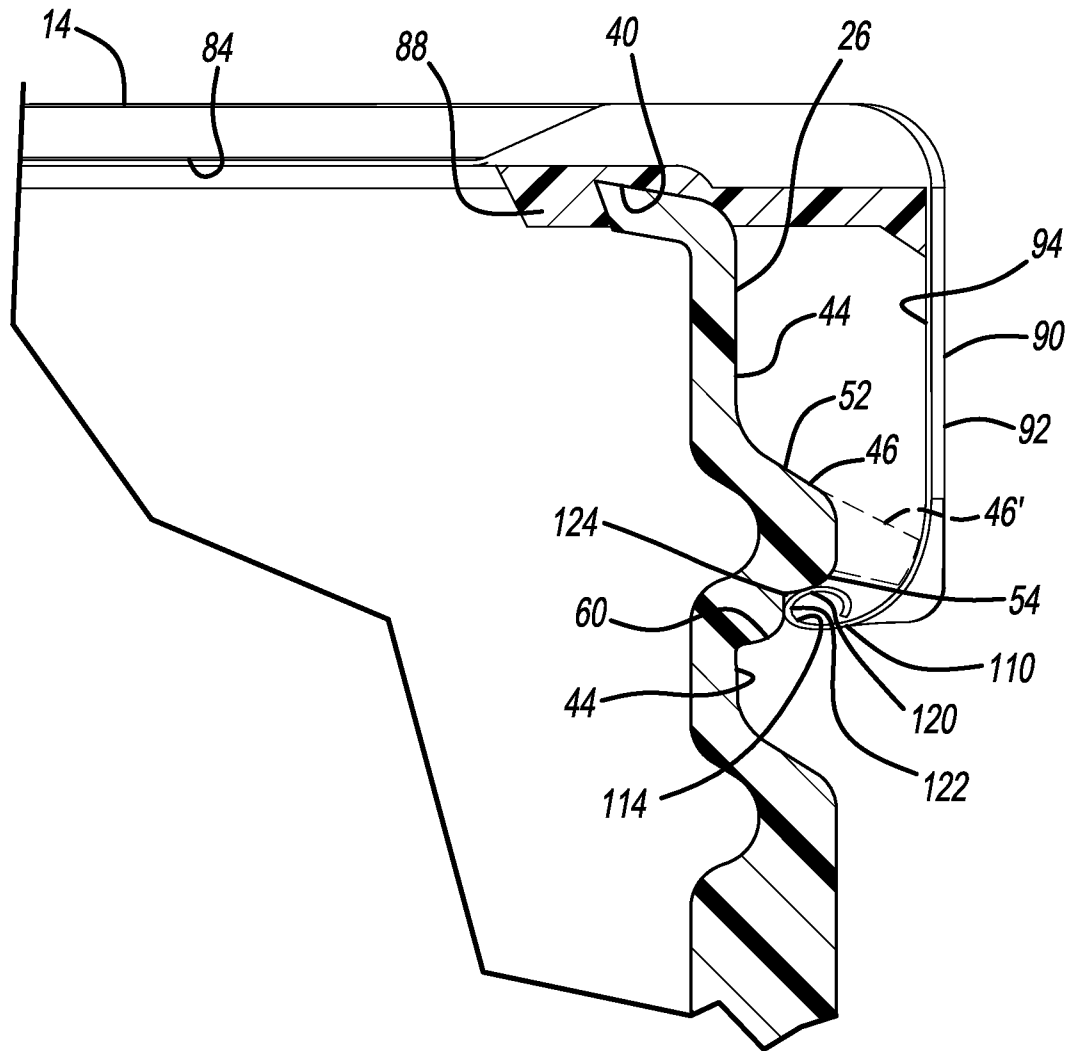

FIG - 12

A. CLASSIFICATION OF SUBJECT MATTER**B65D 41/04(2006.01)i, B65D 1/02(2006.01)i**

According to International Patent Classification (IPC) or to both national classification and IPC

B. FIELDS SEARCHED

Minimum documentation searched (classification system followed by classification symbols)

B65D 41/04; B01F 15/00; B65D 41/06; B29D 2200; B29C 3902; B65D 41/36; B65D 51/16; B65D 43/12; B65D 1/02

Documentation searched other than minimum documentation to the extent that such documents are included in the fields searched

Korean utility models and applications for utility models

Japanese utility models and applications for utility models

Electronic data base consulted during the international search (name of data base and, where practicable, search terms used)

eKOMPASS(KIPO internal) & Keywords:container, closure, thread, lug, lock, and finish

C. DOCUMENTS CONSIDERED TO BE RELEVANT

Category*	Citation of document, with indication, where appropriate, of the relevant passages	Relevant to claim No.
Y	US 2005-0128870 A1 (GARCIA, THIERRY) 16 June 2005 See paragraphs [0028]-[0032],[0035],[0041]-[0042] and figure 1.	1-5,9-10,14
A		6-8,11-13,15-27
Y	US 2005-0242055 A1 (OH, JACK S.) 3 November 2005 See paragraphs [0054],[0075],[0091]-[0092] and figure 18.	1-5,9-10,14
Y	US 6227391 B1 (KING, ROGER MILNER) 8 May 2001 See column 8, lines 28-31 and figure 4.	5
Y	US 6841117 B1 (SMITH et al.) 11 January 2005 See column 1, lines 62-63, column 4, lines 26-32, and figure 1.	14
A	US 2007-0045320 A1 (BIESECKER et al.) 1 March 2007 See paragraphs [0036]-[0037] and figure 8.	1-27

 Further documents are listed in the continuation of Box C. See patent family annex.

* Special categories of cited documents:

"A" document defining the general state of the art which is not considered to be of particular relevance

"E" earlier application or patent but published on or after the international filing date

"L" document which may throw doubts on priority claim(s) or which is cited to establish the publication date of another citation or other special reason (as specified)

"O" document referring to an oral disclosure, use, exhibition or other means

"P" document published prior to the international filing date but later than the priority date claimed

"T" later document published after the international filing date or priority date and not in conflict with the application but cited to understand the principle or theory underlying the invention

"X" document of particular relevance; the claimed invention cannot be considered novel or cannot be considered to involve an inventive step when the document is taken alone

"Y" document of particular relevance; the claimed invention cannot be considered to involve an inventive step when the document is combined with one or more other such documents, such combination being obvious to a person skilled in the art

"&" document member of the same patent family

Date of the actual completion of the international search

23 June 2014 (23.06.2014)

Date of mailing of the international search report

24 June 2014 (24.06.2014)

Name and mailing address of the ISA/KR

International Application Division
Korean Intellectual Property Office
189 Cheongsu-ro, Seo-gu, Daejeon Metropolitan City, 302-701,
Republic of Korea

Facsimile No. +82-42-472-7140

Authorized officer

CHOI, Hyun Goo

Telephone No. +82-42-481-8288

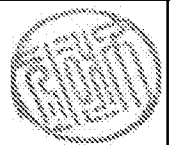

INTERNATIONAL SEARCH REPORT

Information on patent family members

International application No.

PCT/US2014/023370

Patent document cited in search report	Publication date	Patent family member(s)	Publication date
US 2005-0128870 A1	16/06/2005	AU 2003-222931 A1 EP 1476365 A1 FR 2836204 A1 FR 2836204 B1 WO 03-070589 A1	09/09/2003 17/11/2004 22/08/2003 09/04/2004 28/08/2003
US 2005-0242055 A1	03/11/2005	US 7331479 B2 US 7673763 B1	19/02/2008 09/03/2010
US 6227391 B1	08/05/2001	AT 214023 T AU 1998-93604 A1 AU 1998-93604 B2 BR 9812759 A CA 2305445 A1 CA 2305445 C CN 1103726 C CN 1280543 A CN 1280543 C0 DE 69804123 D1 DK 1021352 T3 EP 1021352 A1 EP 1021352 B1 ES 2173622 T3 GB 2330133 A GB 2330133 B GB 9721568 D0 HK 1027078 A1 JP 2001-519299 A PT 1021352 E PT 1021352 T RU 2213683 C2 WO 99-19228 A1	15/03/2002 03/05/1999 15/11/2001 29/08/2000 22/04/1999 05/12/2006 26/03/2003 17/01/2001 17/01/2001 11/04/2002 29/04/2002 26/07/2000 06/03/2002 16/10/2002 14/04/1999 07/11/2001 10/12/1997 26/07/2002 23/10/2001 28/06/2002 28/06/2002 10/10/2003 22/04/1999
US 6841117 B1	11/01/2005	US 6228317 B1 US 6555191 B1	08/05/2001 29/04/2003
US 2007-0045320 A1	01/03/2007	None	