

(19) World Intellectual Property
Organization
International Bureau



(43) International Publication Date
1 September 2005 (01.09.2005)

PCT

(10) International Publication Number
WO 2005/079681 A1

- (51) International Patent Classification⁷: **A61B 17/32**, 17/22, 17/00
- (21) International Application Number: PCT/GB2005/000553
- (22) International Filing Date: 15 February 2005 (15.02.2005)
- (25) Filing Language: English
- (26) Publication Language: English
- (30) Priority Data:
0403512.7 17 February 2004 (17.02.2004) GB
- (71) Applicant (for all designated States except US): **ES-CHMANN HOLDINGS LIMITED** [GB/GB]; Peter Road, Lancing, West Sussex BN15 8TJ (GB).
- (72) Inventor; and
- (75) Inventor/Applicant (for US only): **GONON, Bertrand** [FR/FR]; 25, route Neuve, F-69370 Ternay (FR).
- (74) Agent: **PEEL, James, Peter**; Barker Brettell, 10-12 Priests Bridge, London SW15 5JE (GB).
- (81) Designated States (unless otherwise indicated, for every kind of national protection available): AE, AG, AL, AM, AT, AU, AZ, BA, BB, BG, BR, BW, BY, BZ, CA, CH, CN, CO, CR, CU, CZ, DE, DK, DM, DZ, EC, EE, EG, ES, FI, GB, GD, GE, GH, GM, HR, HU, ID, IL, IN, IS, JP, KE, KG, KP, KR, KZ, LC, LK, LR, LS, LT, LU, LV, MA, MD, MG, MK, MN, MW, MX, MZ, NA, NI, NO, NZ, OM, PG, PH, PL, PT, RO, RU, SC, SD, SE, SG, SK, SL, SY, TJ, TM, TN, TR, TT, TZ, UA, UG, US, UZ, VC, VN, YU, ZA, ZM, ZW.
- (84) Designated States (unless otherwise indicated, for every kind of regional protection available): ARIPO (BW, GH, GM, KE, LS, MW, MZ, NA, SD, SL, SZ, TZ, UG, ZM, ZW), Eurasian (AM, AZ, BY, KG, KZ, MD, RU, TJ, TM), European (AT, BE, BG, CH, CY, CZ, DE, DK, EE, ES, FI, FR, GB, GR, HU, IE, IS, IT, LT, LU, MC, NL, PL, PT, RO, SE, SI, SK, TR), OAPI (BF, BJ, CF, CG, CI, CM, GA, GN, GQ, GW, ML, MR, NE, SN, TD, TG).
- Published:**
— with international search report
- For two-letter codes and other abbreviations, refer to the "Guidance Notes on Codes and Abbreviations" appearing at the beginning of each regular issue of the PCT Gazette.*

(54) Title: NOZZLE FOR USE IN GENERATING A PRESSURE JET OF LIQUID

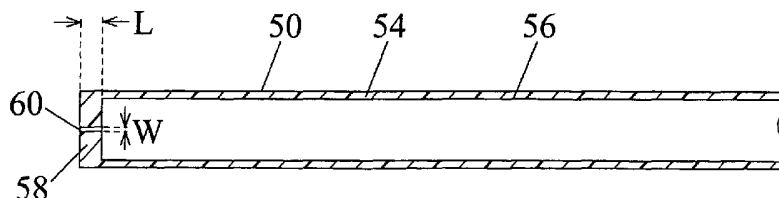

(57) Abstract: A nozzle for use in generating a pressure jet of liquid wherein the nozzle has a proximal end for connection to a source of pressurised liquid and a distal end at which the pressure jet is generated, characterised in that the nozzle comprises a hollow tube having an axial lumen wherein the lumen has a restriction at the distal end in which an orifice is formed wherein the orifice has a width and an axial length, the width of the orifice being less than that of the lumen, and wherein the hollow tube and the restriction are integrally moulded from a plastic material.

WO 2005/079681 A1

NOZZLE FOR USE IN GENERATING A PRESSURE JET OF LIQUID

The present invention relates to a nozzle for use in the generation of a high-pressure liquid jet and to a surgical dissection instrument using a high-pressure liquid jet, comprising a handpiece provided with such a nozzle.

There are numerous known surgical dissection instruments using a high-pressure liquid jet, also known in the art as a lancet. Some of these instruments are relatively complex, and so are quite costly, which means that it is not commercially acceptable for them to be disposable so that are used only once. However, the sterilisation requirements which are imposed on this type of reusable instrument, and the problems posed when reusing it, particularly as regards the risks of contagion, make it virtually obligatory to use it once only.

To solve this problem, the applicant has previously proposed, in EP-A-0840626 and its equivalent US-A-6066150, a surgical dissection instrument using a high-pressure liquid jet having a handpiece which was disposable, yet reliably fulfilled the functions of the handpiece, namely to control the supply and stop the supply of high-pressure liquid, to lock the liquid supply control in the stop position, and to provide a suction function for evacuating fluid and body matter away from the dissection site in the patient's body. The surgical dissection instrument was specially configured as a disposable device, so that it could be used only once in an economically acceptable manner.

The handpiece disclosed in EP-A-0840626 is fitted with a nozzle for generating the jet of high-pressure liquid. As shown in Figure 1, in this known construction the nozzle is a rigid cylindrical metal tube 1 having a narrow bore 2 extending therealong and provided at its distal end with a

sapphire body (or die) 3 having an orifice 4 therein of approximately 0.1mm diameter. The sapphire body 3 is mounted in a preformed setting 5 in the end of the tube 1, and then the end of the tube 1 is deformed to secure the sapphire body 3 in the setting 5. A high pressure jet is emitted from the orifice 4 when pressurized liquid is fed down the narrow bore. The proximal end 6 of the nozzle is securely fitted to an end of a conduit in the handpiece through which the liquid is fed, so that the nozzle is not separated from the handpiece under the action of the fluid pressure during operation. The proximal end 6 is threaded and is fitted to a plastic conduit in the handpiece. The sapphire body 3 is secured within the end of the metal tube 1, so that the sapphire body 3 is also not separated from the nozzle during operation under the action of the fluid pressure. Either eventuality would obviously be very dangerous for the patient, and also the surgical team. Accordingly, the nozzle is permanently fitted to the handpiece, for disposal together with the handpiece after a single use.

A sapphire body has been used in the art because of the need to ensure the safety and integrity of the surgical dissection instrument. The sapphire crystal permits an orifice of precisely controlled diameter to be accurately provided, which resists the very high liquid pressures and is highly resistant to any abrasion in use. The sapphire crystal can readily be securely bonded to a metal nozzle, so as to ensure that the nozzle can safely be subjected to high liquid pressures. However, the use of a sapphire body adds expense and complexity to the manufacture of what is a disposable item. If it is not completely ensured that the sapphire body is permanently and securely bonded into the nozzle, the safety of the device is compromised. The correct and secure disposition of the sapphire body into the setting in the metal tube is problematic and expensive. The metal tube also provides high resistance to high liquid pressures, but can be difficult and expensive to manufacture, and can be difficult to fit to the plastic conduit.

In a later development of the nozzle disclosed in EP-A-0840626, it has also been proposed in the art to use, instead of a sapphire crystal, a metal body which is securely bonded into the end of the nozzle. The metal
5 body has lower cost than the sapphire body. The metal body is a cylindrical plug having an orifice therethrough which can similarly be securely fitted to the metal nozzle so as to ensure safety of the surgical dissection instrument. The metal body is laser welded to the tube. Such a construction is used because it is believed by those in the art to be of
10 primary importance to ensure that the orifice is accurately formed (as it can be in the metal plug) and most importantly that the metal plug is securely bonded into the nozzle bore. However, as for the use of a sapphire body, the use of a metal body inserted into the nozzle and laser welded thereto to provide the orifice adds expense and complexity to the
15 manufacture of what is a disposable item. Again, if it is not completely ensured that the metal plug is permanently and securely bonded into the nozzle, the safety of the device is compromised. It can be difficult to fit the metal tube to the plastic conduit of the handpiece.

20 In addition, the surgical dissection instrument disclosed in EP-A-0840626 requires the rod of the nozzle to be rigid. This reduces the versatility of the surgical dissection instrument.

Other known surgical dissection instruments are disclosed in, for
25 example, US-A-6508823, US-A-6423027, US-A-6423028, and US-A-63222533.

The present invention aims in one aspect to provide a nozzle for
30 generating a pressure jet of liquid and a surgical dissection instrument comprising such a nozzle which ameliorates the problems of the known instruments discussed above.

The present invention aims in another aspect to provide a method of producing a nozzle for a surgical dissection instrument using a high-pressure liquid jet which ameliorates the problems of the known instruments discussed above.

According to the present invention there is provided a nozzle for use in generating a pressure jet of liquid wherein the nozzle has a proximal end for connection to a source of pressurised liquid and a distal end at which the pressure jet is generated, characterised in that the nozzle comprises a hollow tube having an axial lumen wherein the lumen has a restriction at the distal end in which an orifice is formed wherein the orifice has a width and an axial length, the width of the orifice being less than that of the lumen, and wherein the hollow tube and the restriction being integrally moulded from a plastic material.

The orifice preferably has an axis which is substantially parallel with the axis of the lumen. The axial length of the orifice of the nozzle is preferably such that the pressure jet of liquid generated by the nozzle is a surgical pressure jet of liquid. A surgical pressure jet of liquid is a pressure jet of liquid which is particularly suitable for use in surgery. It is preferably a well defined or coherent pressure jet having a length of from 5 to 7 cm (preferably about 6 cm) from the distal end of the nozzle before the pressure jet becomes substantially less well defined or coherent or it becomes a spray.

The nozzle preferably has an additional lumen which is preferably arranged such that the axes of the two lumen are substantially parallel.

According to the invention there is provided a surgical dissection instrument for generating a pressure jet of liquid, the instrument

comprising a handpiece, the handpiece being provided with an inlet conduit for receiving a supply of liquid to form a pressure jet and a nozzle according to the invention wherein the nozzle is in fluid communication with the inlet conduit and extends from the handpiece.

5

The instrument according to the invention preferably has a mechanism for controlling the pressure jet of liquid

The plastic material is preferably a plastics material having mechanical strength, purity, chemical resistance, ease of processing (including mouldability) and sterilization resistance. The plastic material is more preferably a thermoplastic polymeric material, especially a thermoplastic polycondensate. Examples of suitable plastic materials include a polyimide, polycarbonate, polyetheretherketone, polyaryletherketone, polyphenylene oxide, polysulfone and/or a polyphenylene sulphide. Most preferably the plastic material is a polyaryletherketone resin

According to the invention there is also provided a method of manufacturing a nozzle for a surgical dissection instrument for generating a pressure jet of liquid, the method comprising the steps of:

extruding a plastic material to provide a hollow tube having an axial lumen;

moulding an end of the extruded hollow tube to form an integral restriction at the end; and

forming an axially directed orifice which extends through the restriction to the lumen, the width of the orifice being less than that of the lumen.

The method of the invention preferably further comprises the step of cutting the tube to a selected length.

The present invention will now be disclosed in more detail with reference to the description of a preferred form of embodiment given by way of an unrestricted example and illustrated by the attached drawings, in which:

5 **Figure 1** shows an axial sectional view of a nozzle of a known surgical dissection instrument;

Figure 2 shows an axial sectional view of a first embodiment of a hand-operated surgical dissection instrument according to the
10 present invention,

Figure 3 shows an enlarged axial sectional view of the distal end of a first embodiment of a nozzle according to the invention;

15 **Figure 4** shows an axial sectional view of a second embodiment of a hand-operated surgical dissection instrument according to the present invention;

Figure 5 shows an enlarged axial sectional view of the distal end
20 of a second embodiment of a nozzle according to the invention;

Figure 6 shows an enlarged axial sectional view of the distal end of a third embodiment of a nozzle according to the invention;

25 **Figure 7** shows an enlarged transverse sectional view of a nozzle according to the second and third embodiments of the invention taken in the directions A-A' and B-B' shown in Figures 5 and 6, respectively; and

Figure 8 shows an enlarged projection of the distal end of a nozzle according to the second embodiment of the invention as shown in **Figure 5**.

5 With reference to Figures 2 and 3, an embodiment of a surgical dissection instrument according to the invention comprises a handpiece 10, a first flexible tube 13 for connection, in use, to a source (not shown) for supplying a high-pressure physiological salt solution and a second flexible tube 14 for connection, in use, to a suction device (not shown). The first
10 flexible tube 13 is typically reinforced by a reinforcement made of braided synthetic wires, so as to be able to withstand the high pressure of the liquid, which may reach 70 bar.

The handpiece 10 is of the disposable type, made entirely from injection-
15 moulded thermoplastic synthetic material. It primarily comprises an ergonomic body 15 of generally elongated shape, with a substantially circular cross-section, this body extending from a distal end 16 to a proximal end 19, both ends 16, 19 being substantially located on the same axis. The proximal end 19 incorporates an opening through which the
20 tubes 13 and 14 enter the body 15.

The handpiece 10 furthermore comprises a control lever 17, including (as described below) means for pinching the flexible tube 13, and a device 18 for locking the control lever in the closed position in which the tube 13 is
25 sealed and the jet of high-pressure liquid stopped.

The ergonomic body 15 is made up of two substantially identical moulded half shells. The two half shells are hollow on the inside to allow the tubes 13 and 14 to pass inside the body of the handpiece from the proximal end
30 19 to the distal end 16 along a substantially straight path.

The control lever 17 has an outer surface shaped to receive the user's fingers or palm. It is located in a central upper area of the ergonomic body 15 and articulated on a pivot 21 engaged in opposed openings (not shown) in the half shells of the ergonomic body 15 in an area close to the distal end 16. The pivot 21 is in fact comprised of two symmetrical elements each of which is an inwardly directed lug 23, both lugs 23 being arranged spaced from and parallel to one another. The spaced lugs 23 provide a passage (not shown) for the high-pressure physiological salt solution supply tube 13.

10

In an area extending proximal of the passage there is a movable squeezing projection 25 secured to the control lever 17, the movable squeezing projection 25 being positioned facing a fixed squeezing projection 26 secured to the body 15 of the handpiece and designed to cooperate with the latter to squash the tube 13, when the user presses the control lever 17, and instantaneously stop the flow of high-pressure liquid. More precisely, the squeezing projections 25, 26 define between them a space for the tube 13 to pass and they are arranged perpendicular to the tube 13. The movable squeezing projection 25 is designed to move in relation to the fixed squeezing projection 26 so as to reduce said space until it is cancelled thus ensuring that said tube 13 is fully squashed in a direction which is substantially perpendicular to the tube 13. The free end of the control lever 17 defines with the pivot 21 a lever arm D1 and the movable squeezing projection 25 defines with said pivot 21 a lever arm D2 much smaller than D1. The ratio of the lever arms is preferably from 4 to 6. In the embodiment illustrated, the ratio of the lever arms D1, D2 is approximately 5. As a result, the operating force to be applied on the control lever 17 is divided by five. This original construction makes it possible to compress the tube 13 to a greater or lesser extent, even with a very high pressure, by operating the lever with your fingers easily, flexibly and without a large effort being required.

The locking means 18 are primarily comprised of a flexible tongue 27 secured to the ergonomic body 15 of the handpiece 10 and located in a substantially perpendicular plane to the free end of the control lever 17.

5 The tongue 27 bears a catch pin 28 close to its upper end which is fitted with a pusher 29. The catch pin 28 is designed to cooperate with a grip 30 secured to the control lever 17. When the user presses the control lever 17 hard enough, this causes the flow of high-pressure physiological salt solution to stop by pinching the flexible tube 13. In order to release the

10 lever 17, the user acts on the pusher 29, using his thumb, which has the effect of releasing the grip 30 from cooperation with the pin 28. The flexibility of the flexible tube 13 and the pressure of the physiological salt solution conveyed by this tube urge the control lever 17 back to its initial position in which the tube 13 is fully open.

15

The foregoing features of the handpiece 10 of the illustrated first embodiment of a hand-operated surgical dissection instrument of the present invention are substantially disclosed in EP-A-0840626 and its equivalent US-A-6066150.

20

The handpiece 110 of the illustrated second embodiment of a hand-operated surgical dissection instrument of the present invention is a simplified version of the handpiece 10 of the first embodiment. Like features of the two embodiments are identified by like identification

25 numerals. The handpiece 110 of the second embodiment of the invention is suitable for use with a source (not shown) of high pressure physiological salt solution which has means (not shown) for controlling the supply of the salt solution to the handpiece 110, e.g. a foot operated switch. Thus the control lever 17 and associated parts are superfluous in

30 the second embodiment of the handpiece 110 and have been omitted.

In accordance with the present invention, an elongate nozzle 50 of plastic material is securely fitted to the first tube 13. The distal end 31 of first tube 13 and the proximal end 51 of the nozzle 50 are respectively securely fitted to a respective side of an annular collar 52 of plastic material, for example by push fitting the respective ends 31, 51 of the tube 13 and the nozzle 50 into respective annular ends of the collar 52 and then bonding the assembly with adhesive or by thermal bonding.

The nozzle 50 comprises a cylindrical tube 54 defining an axially directed central bore or lumen 56 extending therealong and having at its distal end an integral restriction 58. The restriction 58 is moulded from the plastic material of the tube 54 of the nozzle 50 so as to form a unitary and integral structure, without any connection or interface between the restriction 58 and the tube 54. An axially directed central orifice 60 extends through the restriction 58. The restriction 58 typically has an axial length (L) of from 0.1, preferably from 0.3mm to 2mm, preferably to 1 mm, more preferably to 0.5mm typically approximately 0.8 mm or about 0.4mm, with the orifice 60 having the same axial length. Thus the orifice is an elongated orifice. The diameter of the bore 56, and therefore the diameter of the proximal face of the restriction 58 subjected to liquid pressure in the bore 56 and the internal diameter of the tube 54, is typically from 1.5 to 2.5 mm, more typically approximately 1.7 mm. The internal diameter (W) of the orifice 60 is typically from 0.05 to 0.4 mm, more typically approximately 0.2 mm (e.g. about 0.22mm). The ratio of the axial length L to the internal diameter W is from 1:1, preferably from 1.2:1, more preferably from 1.3:1 to 5:1, preferably to 4.5:1, more preferably to 4:1. Preferably the ratio of L to W is about 1.5:1 or about 3.7:1. This structure of the restriction 56 is sufficient to withstand typical liquid pressures in the nozzle 50 of up to 70 bar without failure or deformation of the restriction 58.

The external diameter of the tube 54 is typically from 2 to 4 mm, more typically approximately 2.3 mm, thereby giving a typical wall thickness of from 0.5 to 2 mm, more typically approximately 0.6 mm. Such a wall thickness, together with the properties of the plastic material employed
5 for the nozzle 50, results in the nozzle being sufficiently flexible that the nozzle 50 can readily be selectively disposed in a curved orientation under manual lateral pressure applied by the surgeon's hand. The nozzle 50 is sufficiently elastic for the nozzle 50 to return to a straight axially aligned configuration when the lateral pressure is removed. This results
10 in a more versatile instrument than the known device which employs a rigid metal nozzle.

The nozzle 50 is typically composed of a thermoplastic polymeric material, especially a thermoplastic polycondensate such as a polyimide,
15 polycarbonate, polyetheretherketone, polyaryletherketone, polyphenylene oxide, polysulfone and/or polyphenylene sulphide. Most preferably it is composed of a polyaryletherketone resin, which exhibits mechanical strength, purity, chemical resistance, ease of processing and sterilization resistance. This material can provide the flexibility, elasticity and
20 resistance to high pressure liquid as discussed above.

The nozzle 50 is a one-piece construction made by the following process so as to form in the tube 54 an integral restriction 58 having the orifice
25 60 therethrough.

In the embodiment, the nozzle 50 is produced in two steps, step 1 being continuous extrusion of the plastic material through an extrusion die defining the outer diameter of the nozzle 50 and having a central mandrel defining the inner diameter of the nozzle 50, and step 2 being
30 thermoforming of the end with a tip-forming machine using specific tooling for the external shape, the thermoforming also forming the orifice

60 by use of a correspondingly shaped and dimensioned pin of the tooling. The orifice may however be formed after the thermoforming step. Most preferably, the plastic material extrusion is extruded as a continuous length, and is cut into individual nozzle length pieces, the
5 cutting being before or after the thermoforming step.

This manufacturing process provides the advantage over the known nozzles described hereinabove that it is not necessary to form two pieces (tube and sapphire needle or tube and metal plug) and then bond them
10 together. A one piece construction is not only easier and less expensive to manufacture, but also it may have greater integrity than a two piece construction, because the internal fluid pressure cannot (as potentially for the known two piece constructions using sapphire/metal plug) cause the restriction part containing the orifice to break away and constitute a
15 highly dangerous projectile under the high liquid pressures typically employed. A plastic tube of indeterminate length can be extruded, the required length can be severed off, and then the restriction can be integrally formed in the tube so that the nozzle has the required length. This readily provides nozzles of infinitely varying length. It is not
20 necessary to form metal tubes having only a single length or a set of tubes having predetermined lengths.

Also, by using a plastic tube for the nozzle, this can readily be securely affixed to the plastic tube or collar in the handpiece for delivering the
25 liquid to the nozzle. A plastic-plastic bond can be achieved by adhesive or thermal bonding. This obviates the need for a threaded coupling between the metal tube and the plastic tube or collar. Again, this avoids the previous need for predetermined nozzle lengths, and the cost of forming a thread. The coupling between the plastic tubes can be more reliably
30 achieved than by using a threaded connection. This enhances the quality control of the instrument.

A manifold 70 is bonded in a fluid-tight manner to the distal end 16 of the ergonomic body 15. The manifold 70 surrounds the proximal portion 72 of the nozzle 50, the remainder of the nozzle 50 extending distally away from the manifold 70. The manifold 70 comprises a relatively large diameter proximal portion 74 attached to the distal end 16 and a relatively small diameter distal portion 76, defining an internal cylindrical surface 78. The manifold 70 defines an internal chamber 80 which is in fluid communication with the second flexible tube 14 which, in use, is connected to a source of suction.

An aspirator tube 82 of plastic material is fitted to the distal portion 76 of the manifold 70, by a proximal end 84 of the aspirator tube 82 being push fitted into the distal portion 76 so that the external surface 83 of the aspirator tube 82 mates with the internal cylindrical surface 78. An external annular stop ring 85 on the external surface 83 controls the depth that the aspirator tube 82 is push-fitted into the manifold 70. The aspirator tube 82 is cylindrical and surrounds the nozzle 50, with the nozzle 50 being substantially axially centrally located in the aspirator tube 82. The distal end 86 of the aspirator tube 82 is located a small distance, about 1 to 2 mm or less, distally of the distal end of the nozzle 50. Therefore the nozzle 50 is totally enclosed within the aspirator tube 82. The distal end 86 of the aspirator tube 82 is provided with at least one vent hole 88 extending through the wall thickness thereof. In the illustrated embodiment there are two diametrically opposed circular vent holes 88, each of a diameter of about 1 to 1.5 mm. The at least one vent hole 88 is provided to obviate the aspirator tube 82 from inadvertently attaching itself to the patient's body under the negative pressure applied to the aspirator tube 82.

The aspirator tube 82 is typically composed of polyvinylchloride and typically has a wall thickness of from 0.25 to 1.0 mm so as to be flexible together with the nozzle 50, with typically the inner diameter being from 3.5 to 5 mm and the outer diameter being from 4 to 6 mm. The aspirator
5 tube 82 is preferably transparent so that a user can readily check that it has not become inadvertently blocked in use.

In a preferred embodiment, the nozzle and aspirator tube can be manufactured as an integral unit, constituting a double lumen, with an
10 inner lumen and a, preferably coaxial, outer lumen. The nozzle and aspirator tube may be coextruded. The nozzle for the liquid jet constitutes the inner lumen and the aspirator tube constitutes the outer lumen. The outer lumen may be adapted to inject a drug; to cause articulation of the inner lumen and/or the outer lumen; to contain an
15 electrode of an electrosurgery unit; to guide a laser beam therealong from a laser; and/or to guide an argon beam, or any of these in combination.

A second embodiment of a nozzle 150 according to the present invention is shown in Figure 5. Nozzle 150 is provided in the form of a cylindrical
20 tube 154 having two substantially parallel lumen or bores 156,157 separated by a web 162. A cross-sectional view of the nozzle 150 taken along line A-A' is shown in Figure 7. Lumen 157 terminates at the distal end of the nozzle 150 with an orifice 164. Lumen 156 terminates at the distal end of the nozzle 150 with an integral restriction 158 having an
25 axially directed central orifice 160 extending through it. An enlarged projection of the distal end of the nozzle 150 is shown in Figure 8. This Figure shows orifice 164 of lumen 157 and orifice 160 of lumen 156. The length of the integral restriction 158 and the width of the orifice 160 are substantially the same as the integral restriction 58 and orifice 60 for
30 the first embodiment of the nozzle according to the invention. Lumen

157 is useful for the injection of a fluid, e.g. a medicament or for containing an electrode of an electrosurgery unit.

A third embodiment of a nozzle 250 according to the present invention is shown in Figure 6. Nozzle 250 is provided in the form of a cylindrical tube 254 having two substantially parallel lumen or bores 256,257 separated by a web 262. A cross-sectional view of the nozzle 250 taken along line B-B' is shown in Figure 7. Lumen 257 terminates at the distal end of the nozzle 250 with an integral restriction 258 such that the distal end of lumen 257 is closed. Lumen 256 terminates at the distal end of the nozzle 250 with an integral restriction 258 having an axially directed central orifice 260 extending through it. The length of the integral restriction 258 and the width of the orifice 260 are substantially the same as the integral restriction 58 and orifice 60 for the first embodiment of the nozzle according to the invention. Lumen 257 is useful for containing a stiffening element (not shown) such as a wire, particularly a metal wire. This is useful because it enables that the nozzle according to the third embodiment of the invention to be used in laparoscopic (or "key hole") surgery. In laparoscopic surgery, movement of the nozzle inside a patient's body is controlled from outside the patient's body. For this to work, the nozzle must not be flexible. Therefore, the stiffening element in lumen 257 is useful because it can provide sufficient stiffness for the nozzle to be used in this way.

25 The present invention is not restricted to the forms of embodiment described, but can undergo various alterations and be presented in various aspects derived from the forms described in an obvious manner for a person skilled in the art. For example, although the illustrated embodiment of the surgical dissection instrument for generating a pressure jet of liquid includes a handpiece incorporating a mechanical clamp for opening and closing the tube for supplying the liquid to form

the jet, other handpiece constructions may be used, for example using a pneumatic control for the liquid to form the jet. Other types of handpiece suitable for use in the surgical dissection instrument of the invention are known to those skilled in the art and are encompassed within the scope of

5 the present invention.

CLAIMS

1. A nozzle for use in generating a pressure jet of liquid wherein the nozzle has a proximal end for connection to a source of pressurised liquid
5 and a distal end at which the pressure jet is generated, characterised in that the nozzle comprises a hollow tube having an axial lumen wherein the lumen has a restriction at the distal end in which an orifice is formed wherein the orifice has a width and an axial length, the width of the orifice being less than that of the lumen, and wherein the hollow tube and
10 the restriction being integrally moulded from a plastic material.
2. A nozzle as defined in Claim 1 wherein the axial length of the orifice is such that the pressure jet of liquid generated by the nozzle is a surgical pressure jet of liquid.
15
3. A nozzle as defined in Claim 1 or Claim 2 wherein the ratio of the axial length of the orifice to its width is 1:1 to 5:1.
4. A nozzle as defined in any one of the preceding Claims wherein the
20 nozzle has an additional lumen which is preferably arranged such that the axes of the two lumen are substantially parallel.
5. A nozzle as defined in Claim 4 wherein the additional lumen is closed at its distal end.
25
6. A nozzle as defined in Claim 4 or Claim 5 wherein the additional lumen contains a stiffening element, which is preferably a wire, especially a metal wire.
- 30 7. A nozzle as defined in any one of Claims 1 to 5, wherein the nozzle is sufficiently flexible that the nozzle can be selectively disposed

in a curved orientation under manual lateral pressure applied by a surgeon's hand during dissection on a patient.

8. A nozzle as defined in Claim 7 which is sufficiently elastic for the nozzle to return to a straight axially aligned configuration when the lateral pressure is removed.

9. A nozzle as defined in any one of the preceding Claims which is composed of a thermoplastic polymeric material, preferably a thermoplastic polycondensate, especially a polyaryletherketone resin.

10. A nozzle substantially as hereinbefore described or as depicted in Figures 3 and 5 to 8.

11. A surgical dissection instrument for generating a pressure jet of liquid, the instrument comprising a handpiece, the handpiece being provided with an inlet conduit for receiving a supply of liquid to form a pressure jet and a nozzle as defined in any one of the preceding Claims wherein the nozzle is in fluid communication with the inlet conduit and extends from the handpiece.

12. An instrument as defined in Claim 11, which has a mechanism for controlling the pressure jet of liquid

13. An instrument as defined in Claim 11 or Claim 12, wherein the handpiece further comprises an annular collar of plastic material which connects the nozzle to the inlet conduit, the respective ends of the hollow tube and the inlet conduit being push fitted into respective annular ends of the collar and the push-fitted assembly being bonded with adhesive or by thermal bonding.

14. An instrument as defined in any one of Claims 11 to 13, wherein the handpiece further comprises a manifold at a distal end thereof, the manifold surrounding a proximal portion of the nozzle and defining an internal chamber which is in fluid communication with a suction tube
5 which extends through the handpiece and, in use, is connected to a source of suction.

15. An instrument as defined in Claim 14, wherein the handpiece further comprises an aspirator tube of plastic material fitted to a distal
10 portion of the manifold, the aspirator tube being cylindrical and surrounding the nozzle.

16. An instrument as defined in Claim 15, wherein the aspirator tube has a wall thickness such that it is sufficiently flexible that the aspirator
15 tube can be selectively disposed in a curved orientation under manual lateral pressure applied by a surgeon's hand during dissection on a patient.

17. An instrument as defined in Claim 15 or Claim 16, wherein a
20 proximal end of the aspirator tube is push fitted into the distal portion of the manifold.

18. An instrument substantially as hereinbefore described or as depicted in Figure 2 or Figure 4.

25

19. A method of manufacturing a nozzle for a surgical dissection instrument for generating a pressure jet of liquid, the method comprising the steps of:

extruding a plastic material to provide a hollow tube having an
30 axial lumen;

moulding an end of the extruded hollow tube to form an integral restriction at the end; and

forming an axially directed orifice which extends through the restriction to the lumen, the width of the orifice being less than that of
5 the lumen.

20. A method as defined in Claim 19, further comprising the step of cutting the tube to a selected length.

10 21. A method as defined in Claim 19 or Claim 20, wherein the nozzle is sufficiently flexible that the nozzle can be selectively disposed in a curved orientation under manual lateral pressure applied by a surgeon's hand during dissection on a patient.

15 22. A method as defined in Claim 21, wherein the nozzle is sufficiently elastic for the nozzle to return to a straight axially aligned configuration when the lateral pressure is removed.

20 23. A method as defined in any one of Claims 19 to 22, wherein the plastic material is a thermoplastic polymeric material, preferably a thermoplastic polycondensate, especially a polyaryletherketone resin.

FIG. 1(PRIOR ART)

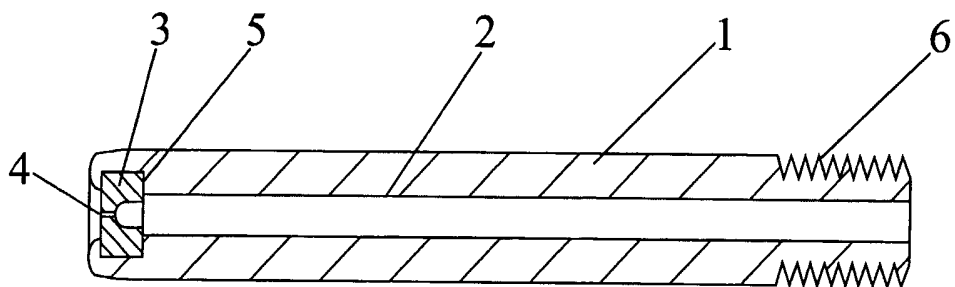

FIG. 3

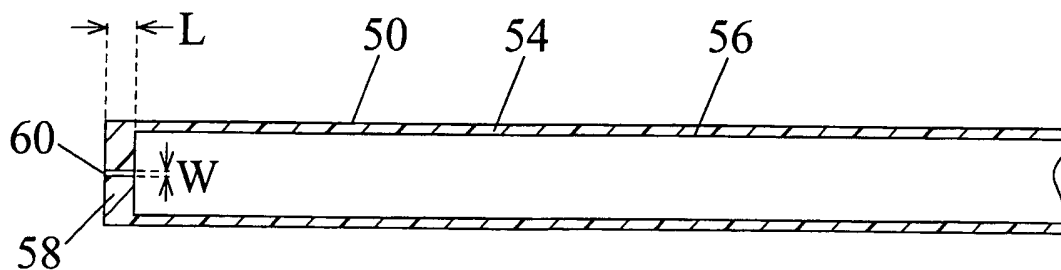
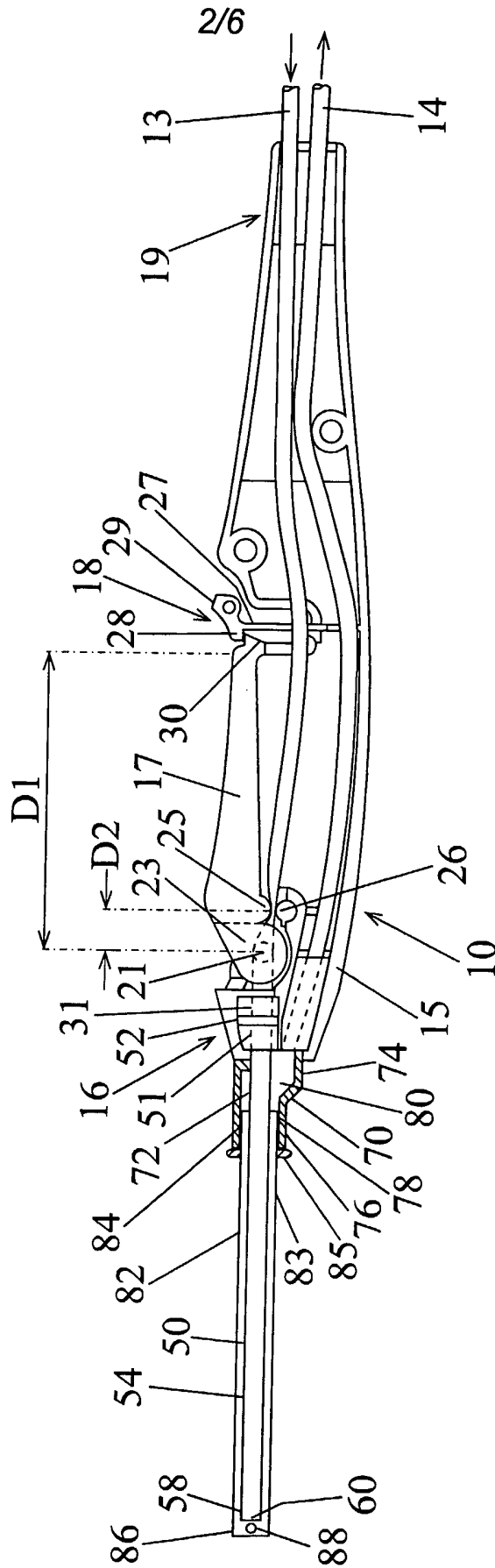

FIG. 2



3/6

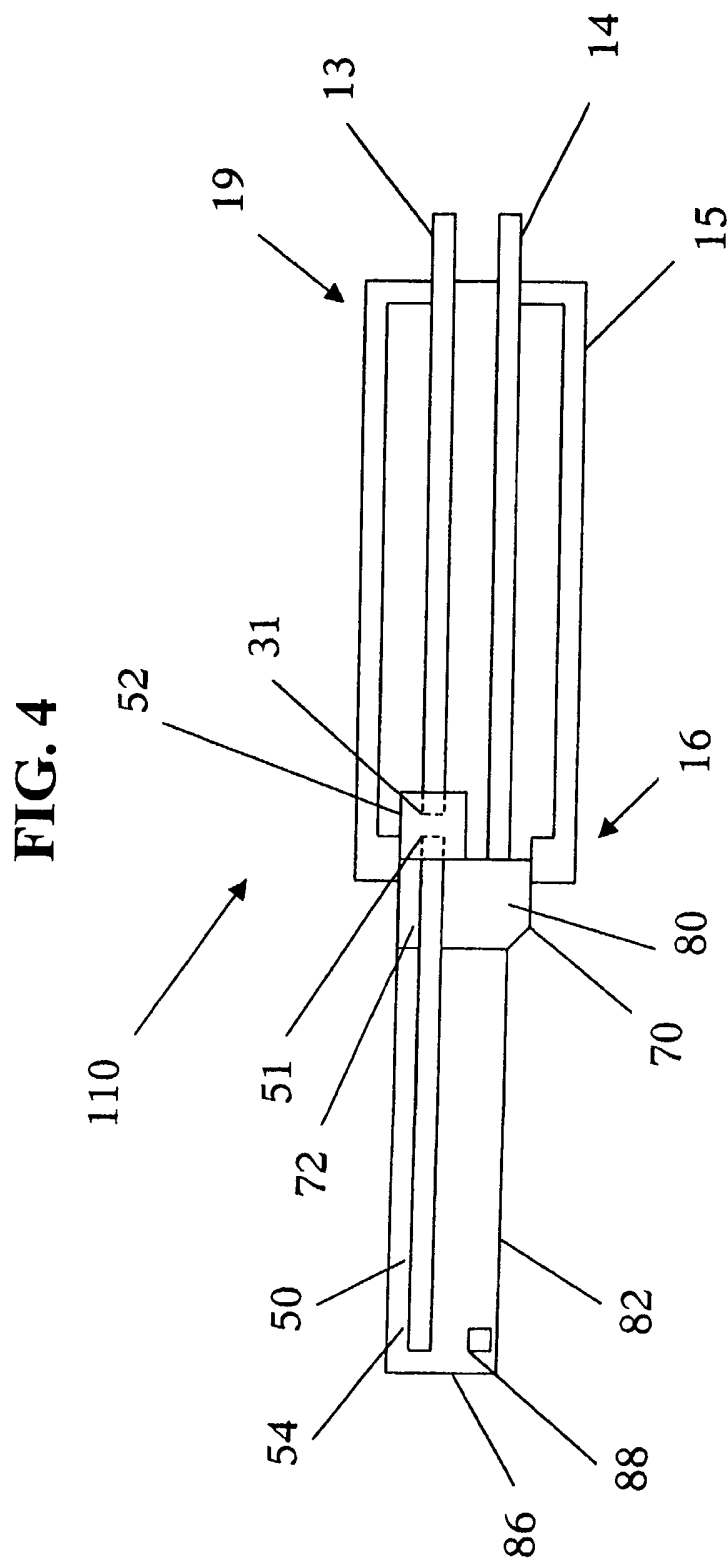

FIG. 5

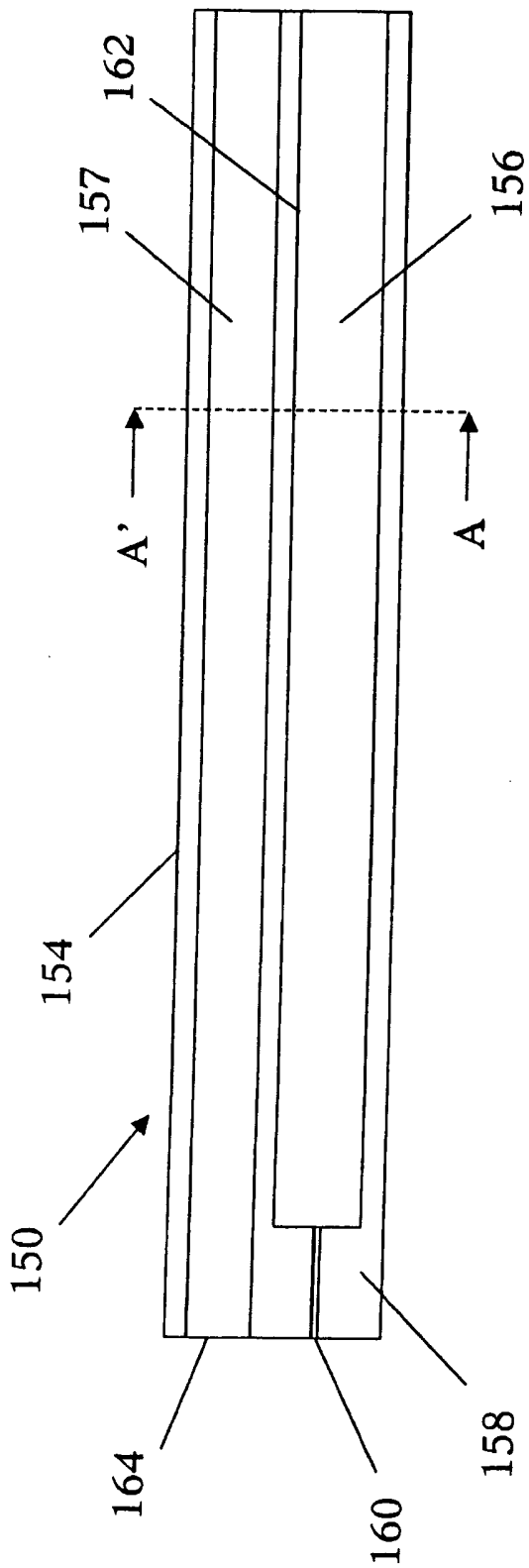

FIG. 6

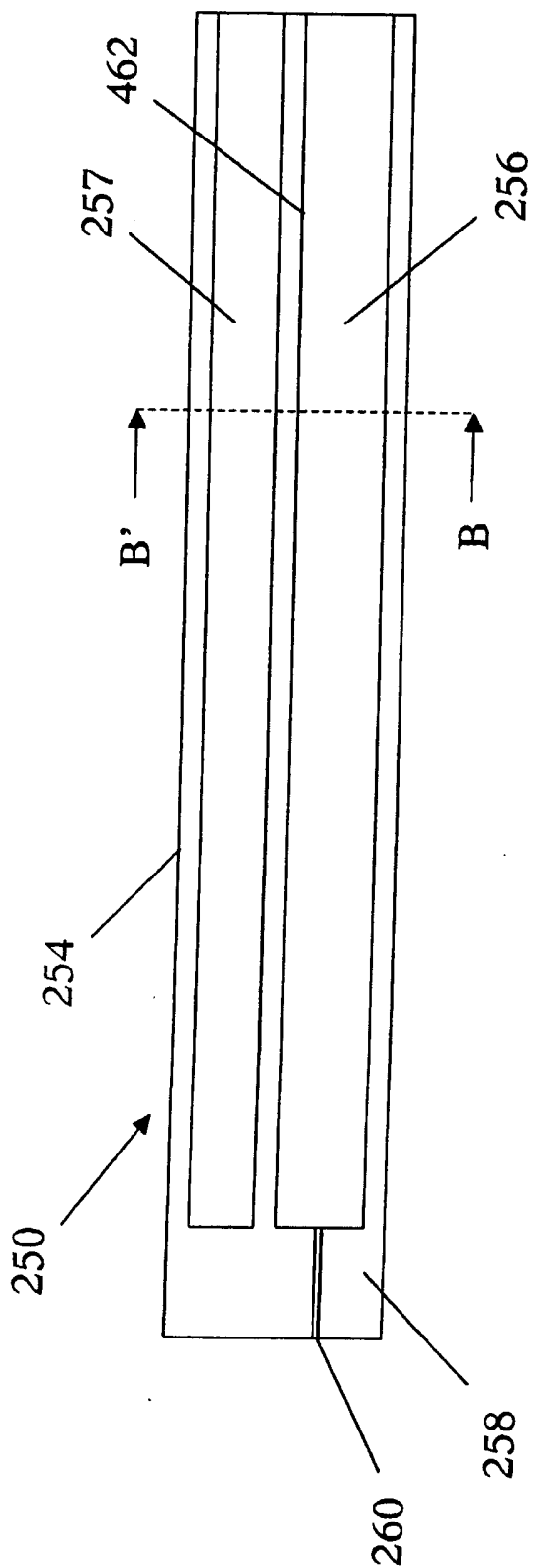

FIG. 7

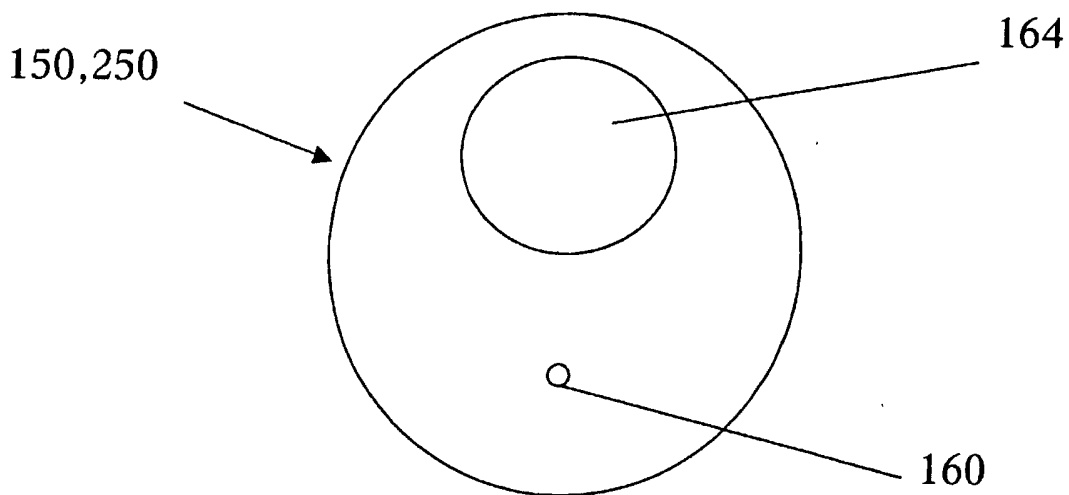
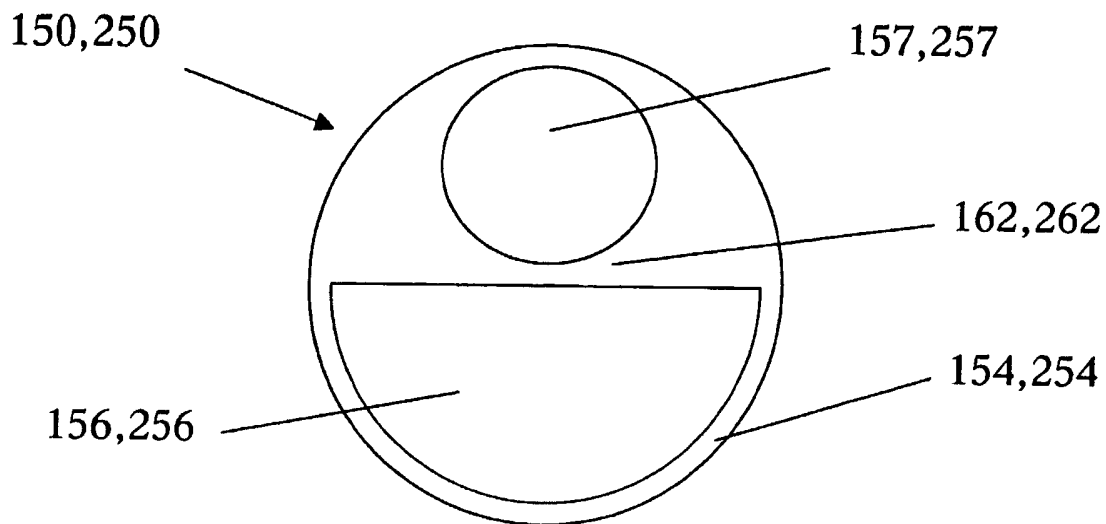

FIG. 8

INTERNATIONAL SEARCH REPORT

PCT/GB2005/000553

A. CLASSIFICATION OF SUBJECT MATTER		
IPC 7 A61B17/32 A61B17/22 A61B17/00		
According to International Patent Classification (IPC) or to both national classification and IPC		
B. FIELDS SEARCHED		
Minimum documentation searched (classification system followed by classification symbols)		
IPC 7 A61B A61M		
Documentation searched other than minimum documentation to the extent that such documents are included in the fields searched		
Electronic data base consulted during the international search (name of data base and, where practical, search terms used)		
EPO-Internal		
C. DOCUMENTS CONSIDERED TO BE RELEVANT		
Category °	Citation of document, with indication, where appropriate, of the relevant passages	Relevant to claim No.
X	US 4 898 574 A (UCHIYAMA ET AL) 6 February 1990 (1990-02-06) column 5, line 38 - column 7, line 16	1-13, 18-23
Y	figures 13,15	14-17
X	DE 34 21 390 A1 (SCHUBERT, WERNER, DR. MED; SCHUBERT, WERNER, DR. MED., 4330 MUELHEIM, DE) 12 December 1985 (1985-12-12) claims 1-3	1-13, 18-23
Y	figure 1	14-17
X	DE 199 04 640 A1 (WITTENSTEIN GMBH & CO. KG) 10 August 2000 (2000-08-10) column 1, line 40 - column 3, line 18 figures 1,3,4	1-3
	----- -/-- -----	
<input checked="" type="checkbox"/> Further documents are listed in the continuation of box C. <input checked="" type="checkbox"/> Patent family members are listed in annex.		
° Special categories of cited documents :		
A document defining the general state of the art which is not considered to be of particular relevance *E* earlier document but published on or after the international filing date *L* document which may throw doubts on priority claim(s) or which is cited to establish the publication date of another citation or other special reason (as specified) *O* document referring to an oral disclosure, use, exhibition or other means *P* document published prior to the international filing date but later than the priority date claimed		*T* later document published after the international filing date or priority date and not in conflict with the application but cited to understand the principle or theory underlying the invention *X* document of particular relevance; the claimed invention cannot be considered novel or cannot be considered to involve an inventive step when the document is taken alone *Y* document of particular relevance; the claimed invention cannot be considered to involve an inventive step when the document is combined with one or more other such documents, such combination being obvious to a person skilled in the art. *&* document member of the same patent family
Date of the actual completion of the international search		Date of mailing of the international search report
13 May 2005		24/05/2005
Name and mailing address of the ISA European Patent Office, P.B. 5818 Patentlaan 2 NL - 2280 HV Rijswijk Tel. (+31-70) 340-2040, Tx. 31 651 epo nl, Fax: (+31-70) 340-3016		Authorized officer Compos, F

INTERNATIONAL SEARCH REPORT

PCT/GB2005/000553

C.(Continuation) DOCUMENTS CONSIDERED TO BE RELEVANT		
Category °	Citation of document, with indication, where appropriate, of the relevant passages	Relevant to claim No.
X	DE 195 06 002 A1 (SCHALLER, GUENTER, 79110 FREIBURG, DE) 22 August 1996 (1996-08-22) the whole document -----	1-3
Y	US 6 423 027 B1 (GONON BERTRAND) 23 July 2002 (2002-07-23) column 4, line 56 - column 5, line 23 figures 3,4 -----	14-17
A	US 6 110 164 A (VIDLUND ET AL) 29 August 2000 (2000-08-29) column 3, line 3 - column 4, line 40 figures 2-6 -----	5,6
A	US 2003/125660 A1 (MOUTAFIS TIMOTHY E ET AL) 3 July 2003 (2003-07-03) page 13, paragraph 103 - page 14, paragraph 104 figures 7A,7B -----	11,13

INTERNATIONAL SEARCH REPORT

PCT/GB2005/000553

Patent document cited in search report		Publication date	Patent family member(s)	Publication date
US 4898574	A	06-02-1990	JP 62261346 A	13-11-1987
			JP 62261347 A	13-11-1987
			JP 62261352 A	13-11-1987
			DE 3715418 A1	12-11-1987

DE 3421390	A1	12-12-1985	NONE	

DE 19904640	A1	10-08-2000	WO 0045719 A2	10-08-2000
			EP 1148828 A2	31-10-2001

DE 19506002	A1	22-08-1996	NONE	

US 6423027	B1	23-07-2002	DE 19912844 A1	28-09-2000
			AU 3438100 A	09-10-2000
			AU 3438200 A	09-10-2000
			EP 1164946 A1	02-01-2002
			EP 1164947 A1	02-01-2002
			WO 0056232 A1	28-09-2000
			WO 0056233 A1	28-09-2000
			JP 2002538929 T	19-11-2002
			JP 2002538930 T	19-11-2002

US 6110164	A	29-08-2000	AU 9218198 A	28-06-1999
			WO 9929360 A1	17-06-1999

US 2003125660	A1	03-07-2003	AU 2002364122 A1	10-06-2003
			CA 2495911 A1	05-06-2003
			EP 1485032 A1	15-12-2004
			WO 03045259 A1	05-06-2003
