



(19) **United States**

(12) **Patent Application Publication**
Prelewitz et al.

(10) **Pub. No.: US 2006/0043302 A1**

(43) **Pub. Date: Mar. 2, 2006**

(54) **DIGITAL IMAGING ASSEMBLY & METHODS THEREOF**

(60) Provisional application No. 60/518,918, filed on Nov. 10, 2003.

Publication Classification

(76) Inventors: **David F. Prelewitz**, Rochester, NY (US); **Robert W. Gray**, Rochester, NY (US); **Rolf Gerchberg**, Long Meadow, MA (US); **Michael L. Weiner**, Webster, NY (US)

(51) **Int. Cl.**
G01J 5/02 (2006.01)
(52) **U.S. Cl.** **250/341.1**

(57) **ABSTRACT**

A coherent radiation imaging system that produces digital images with a reduced amount of speckle. Radiation from a long coherence length source is used to form an image of a sample. The output coherent wave is temporally divided into a plurality of wavelets. The spatial phase of each wavelet is then modulated a known and different amount. Each phase modulated wavelet illuminates the sample and is perturbed by its interaction with the sample. A spatial phase map of each perturbed wavelet is then created and converted to a sample image with an image reconstruction program. The plurality of sample images thus formed is statistically averaged to form a final averaged image. The high frequency speckle that is not optically resolvable tends to average to zero with continual statistical averaging, leaving only the optically resolvable lower frequency phase information.

Correspondence Address:
BUCHANAN INGERSOLL PC
(INCLUDING BURNS, DOANE, SWECKER & MATHIS)
POST OFFICE BOX 1404
ALEXANDRIA, VA 22313-1404 (US)

(21) Appl. No.: **11/205,147**

(22) Filed: **Aug. 17, 2005**

Related U.S. Application Data

(63) Continuation-in-part of application No. 10/983,053, filed on Nov. 5, 2004.

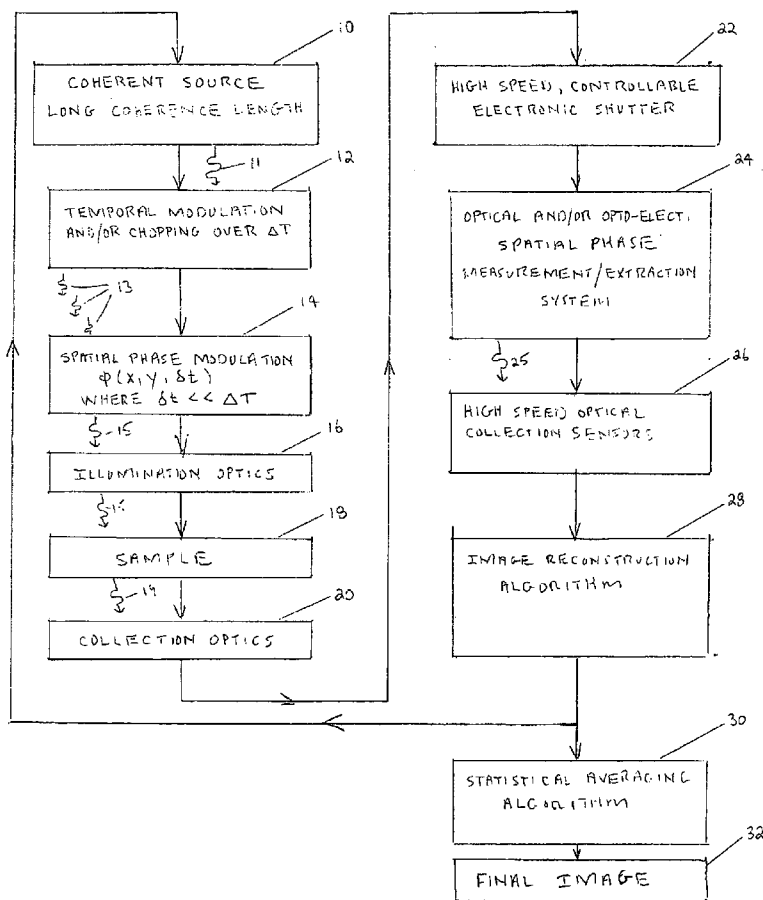
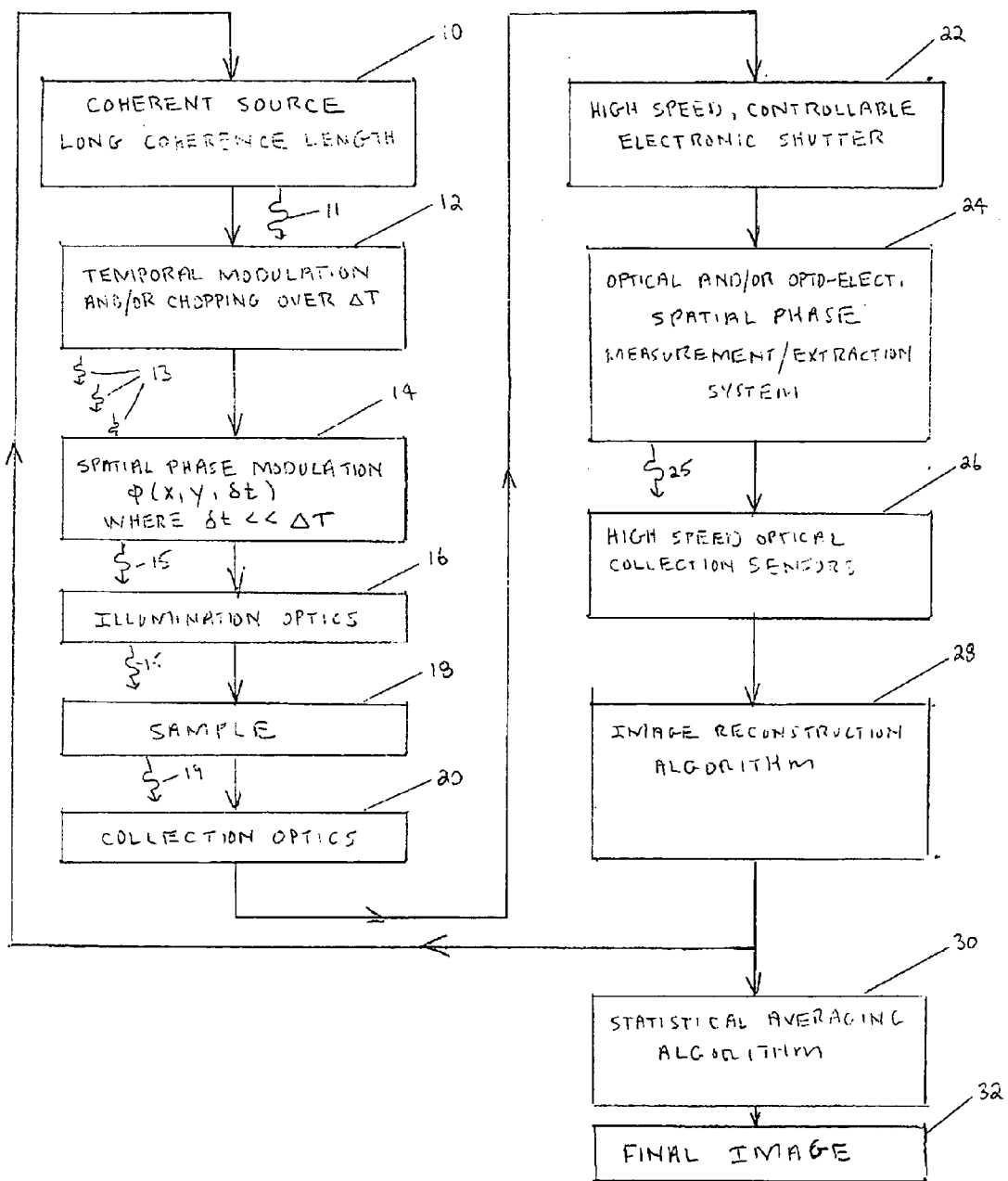

Fig. 1



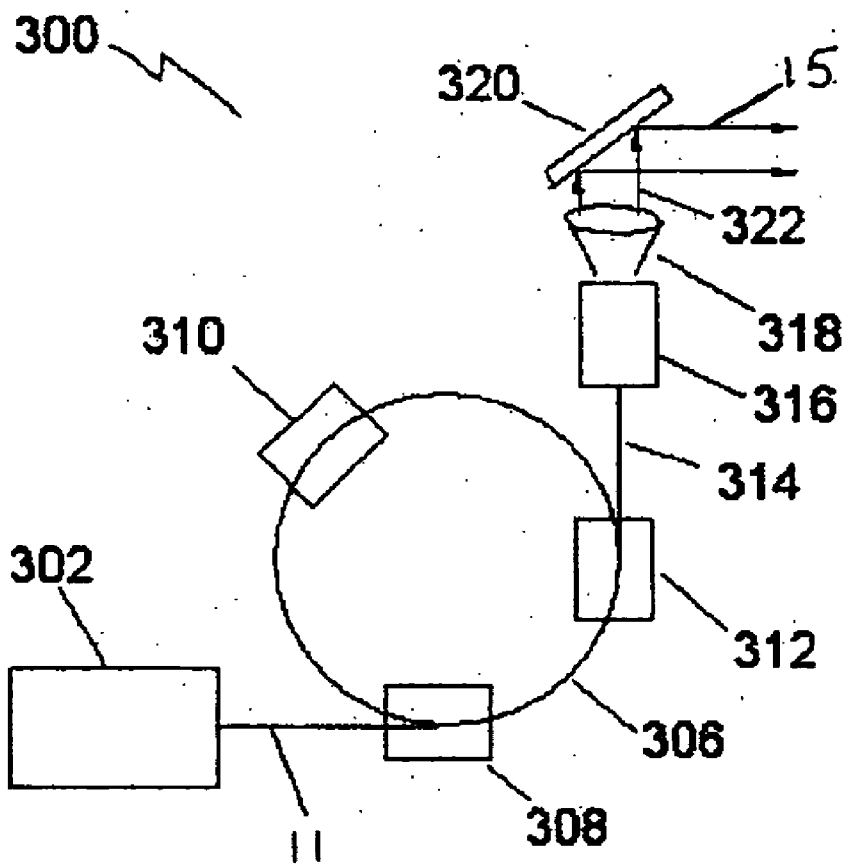
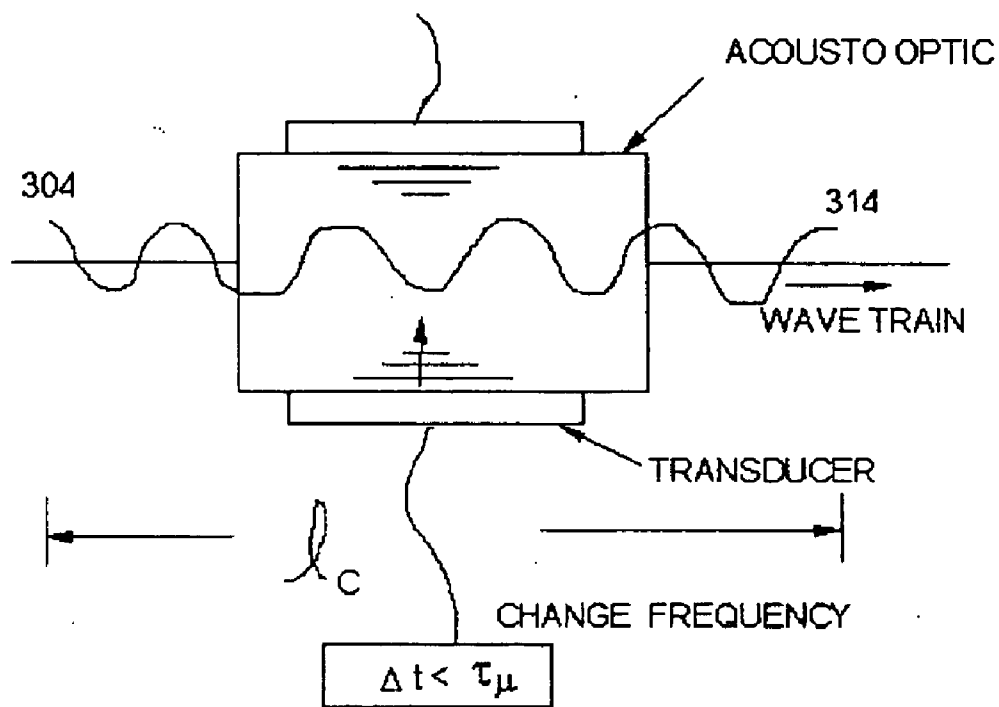

Figure 2A



ENCODE DIFFRACTIVE
MARKERS TO BREAK UP
TEMPORAL COHERENCE IN
A CONTROLLED AND UNDERSTOOD WAY

Figure 2B

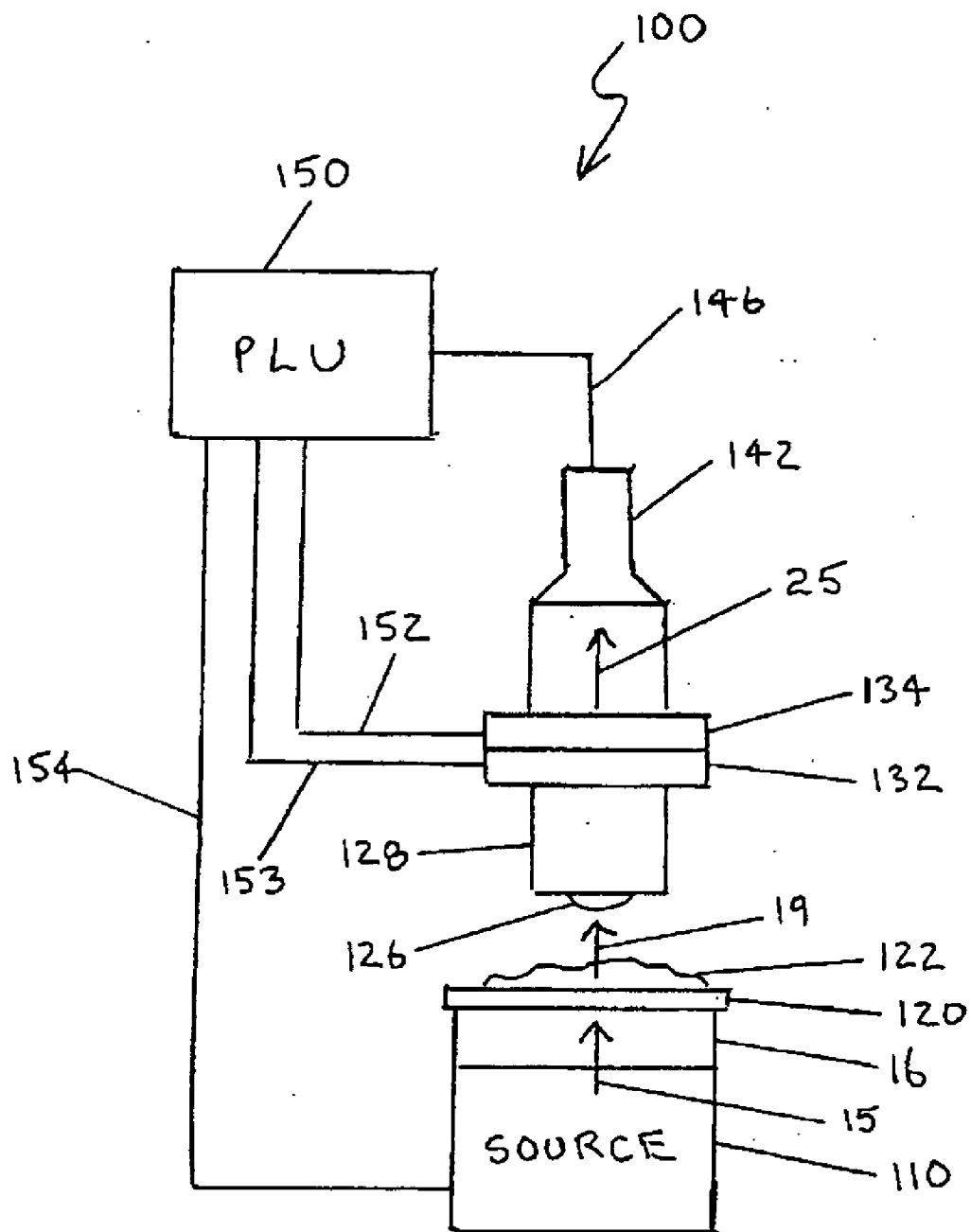

Fig. 3

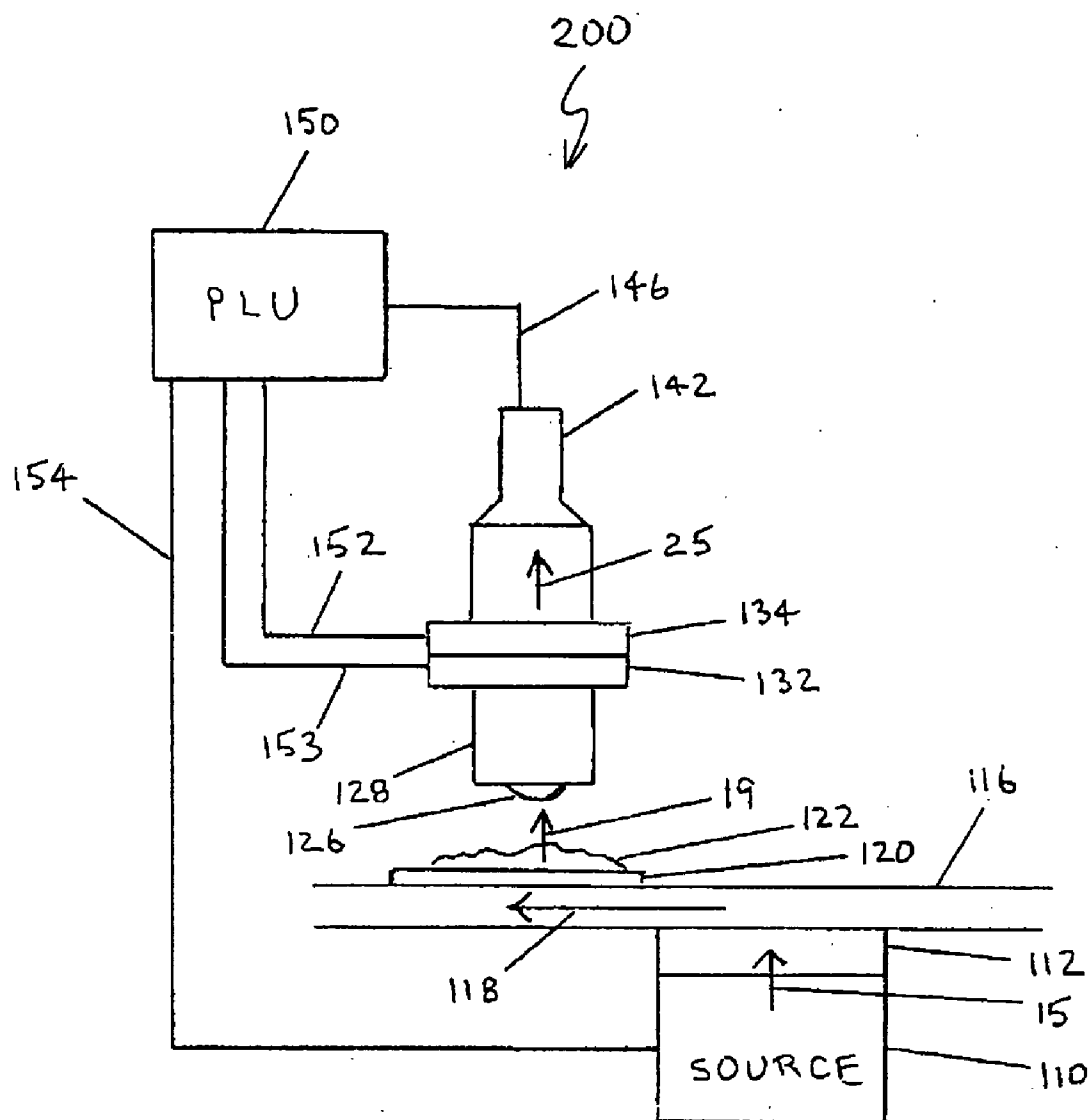

Fig. 4A

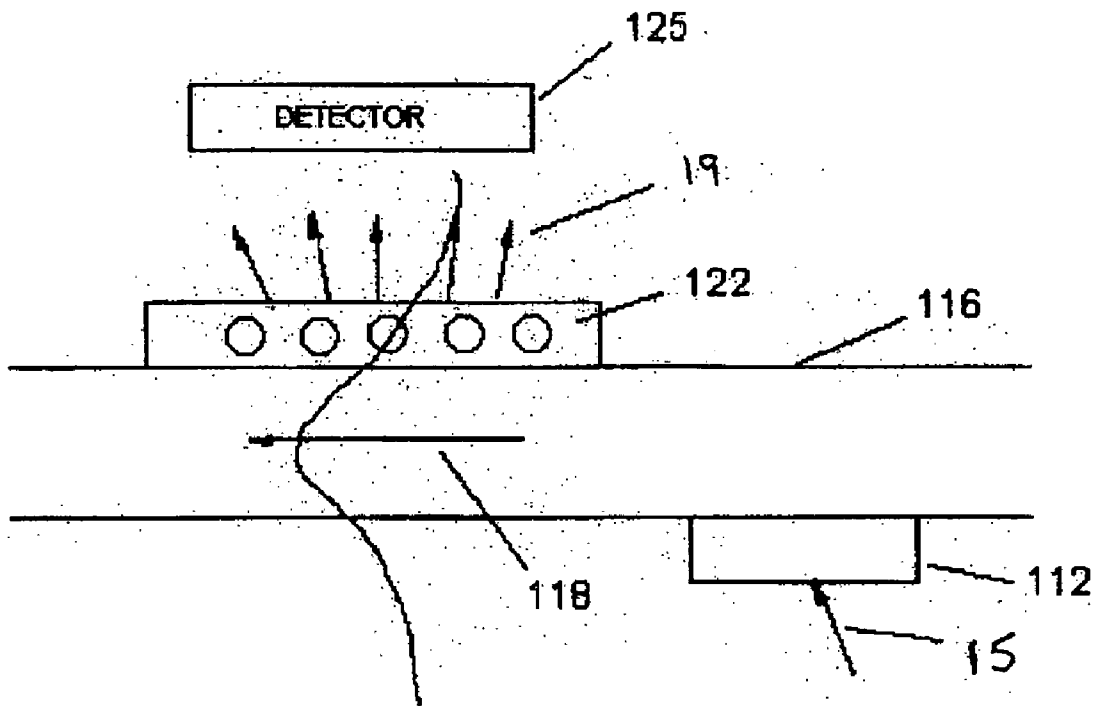
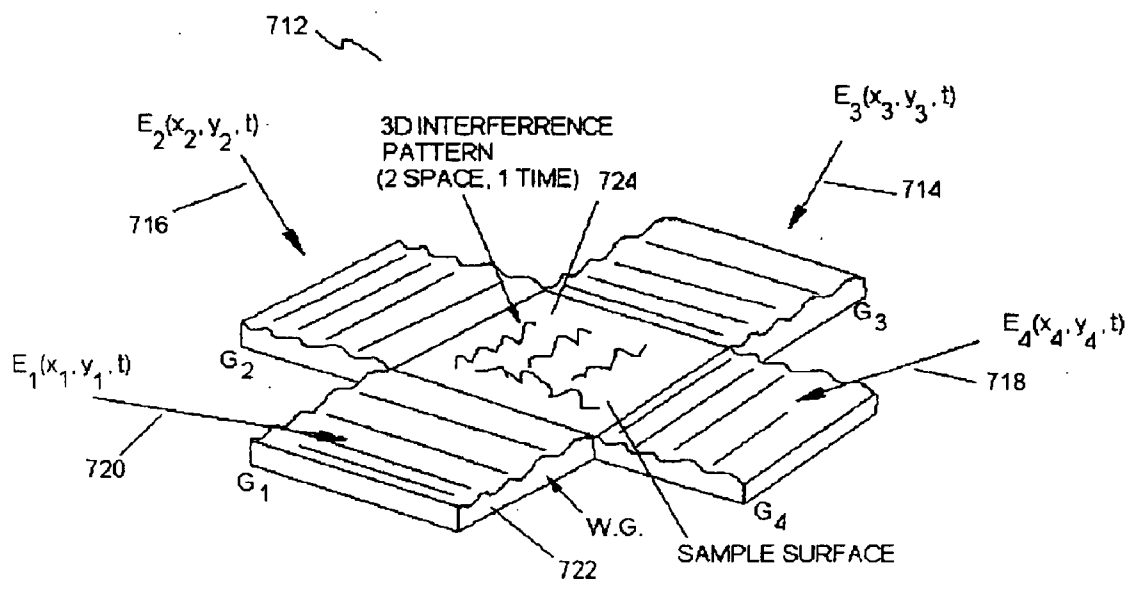

Figure 4B



W.G. = WAVEGUIDE
 E = ELECTRIC FIELD
 G = GRATING COUPLER

Figure 4C

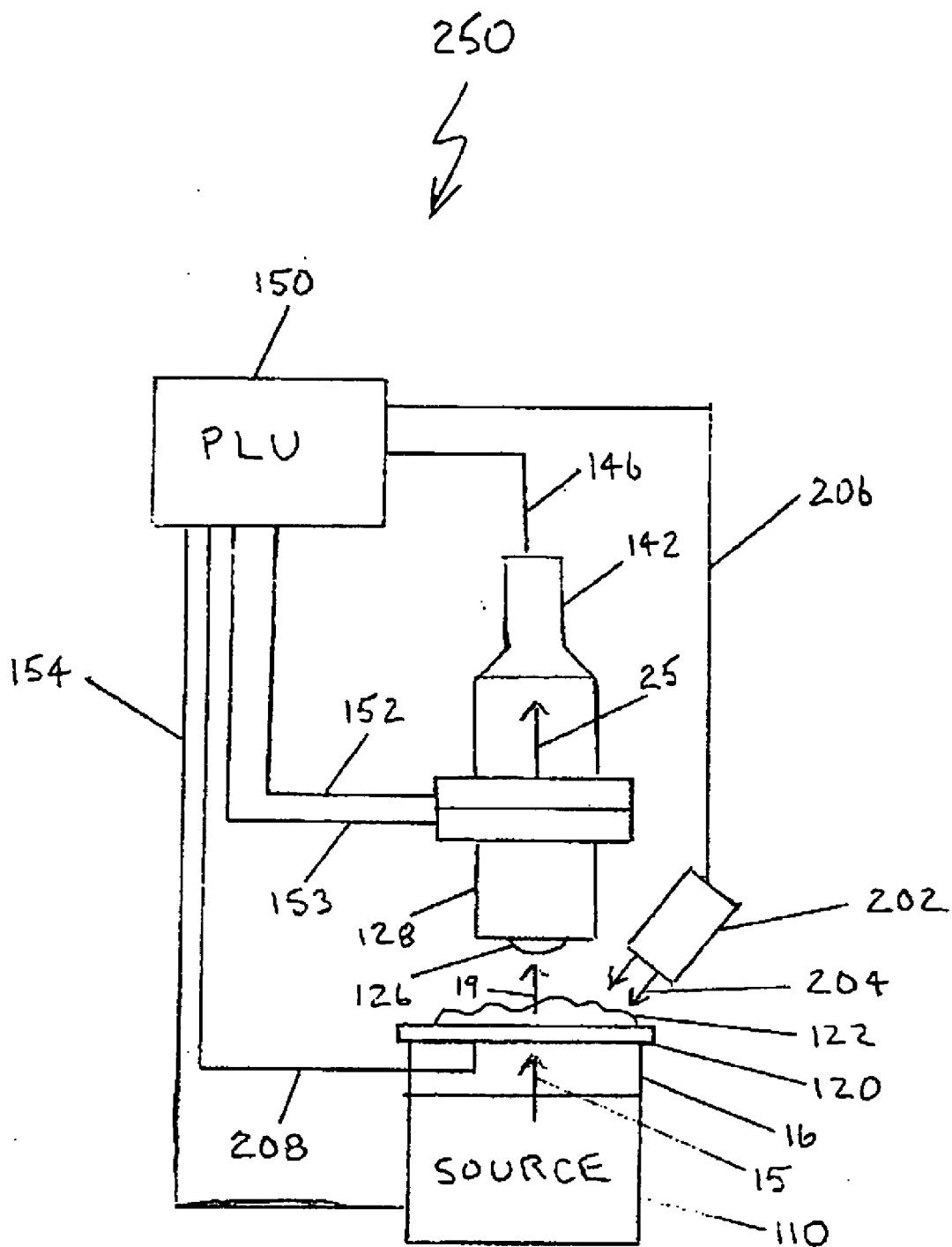

Fig. 5

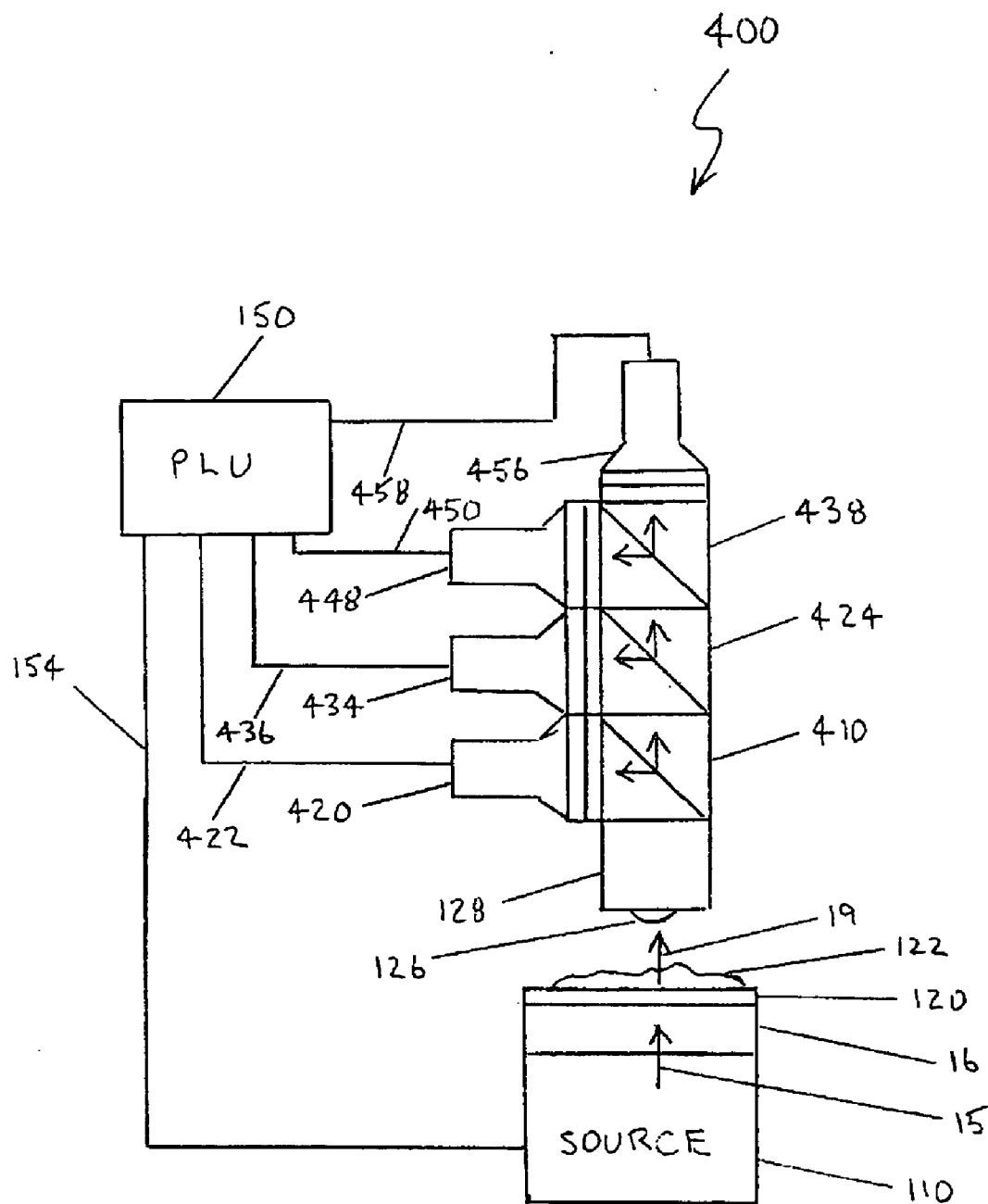

Fig. 6

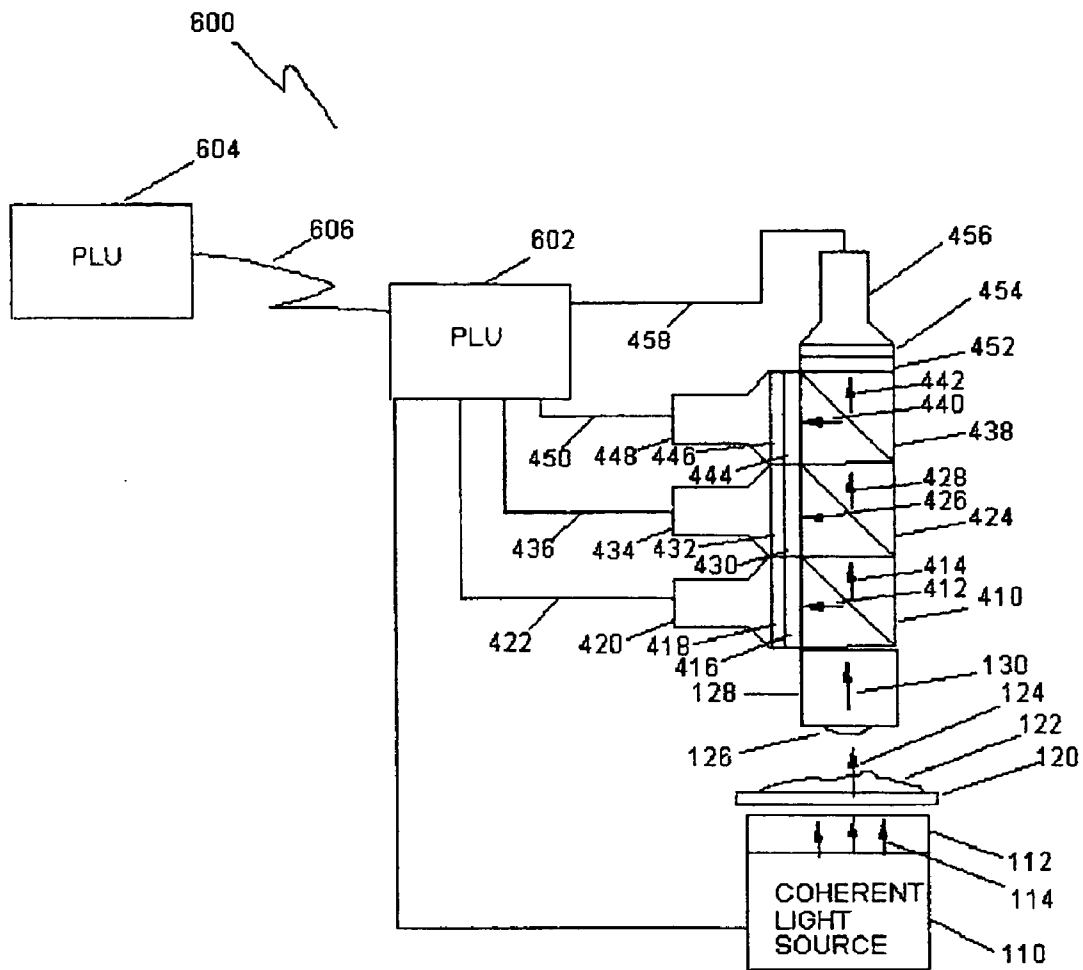
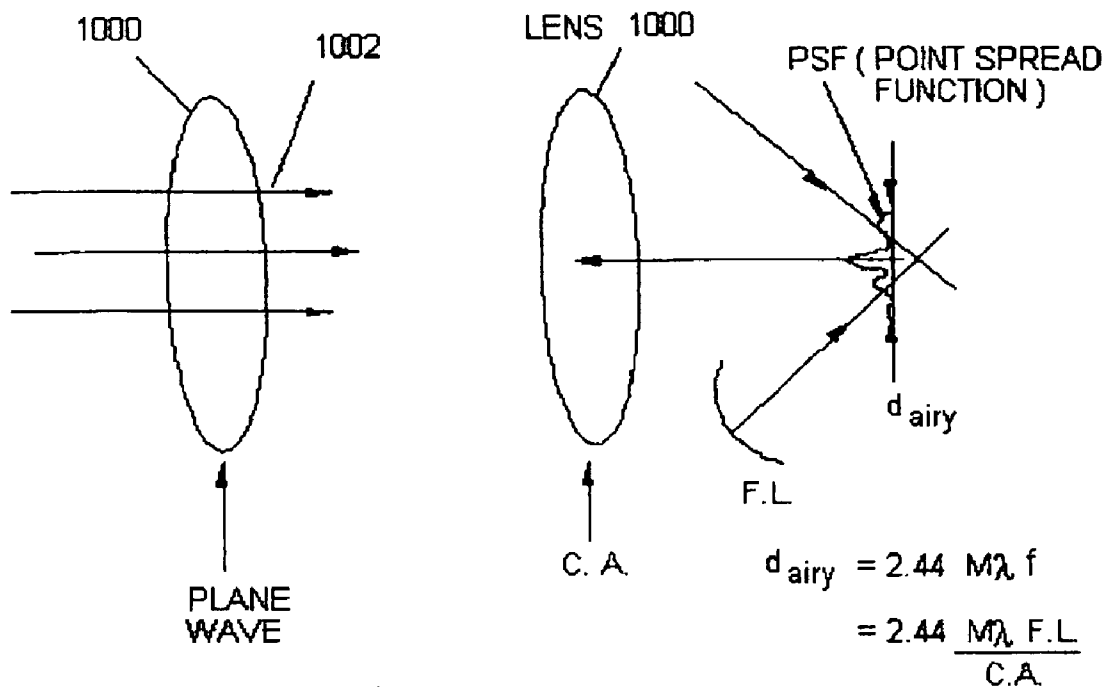

Figure 7



d_{airy} = Airy DISK DIAMETER

M = OPTICAL MAGNIFICATION

λ = WAVE LENGTH

C.A. = APEATURE DIAMETER OF THE IMAGING SYSTEM

F.L. = FOCAL LENGTH OF IMAGING SYSTEM

PSF = POINT PSREAD FUNCTION OF THE IMAGING SYSTEM

Figure 8

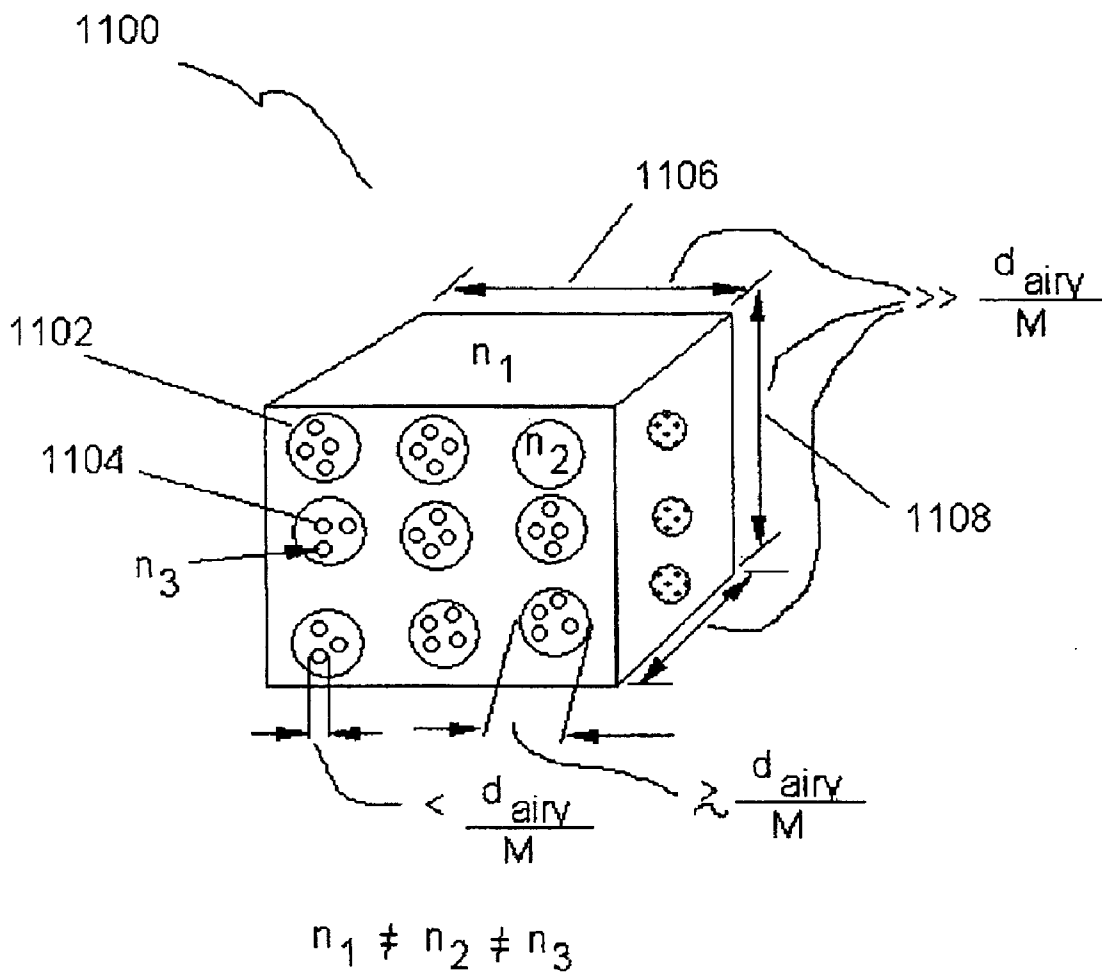
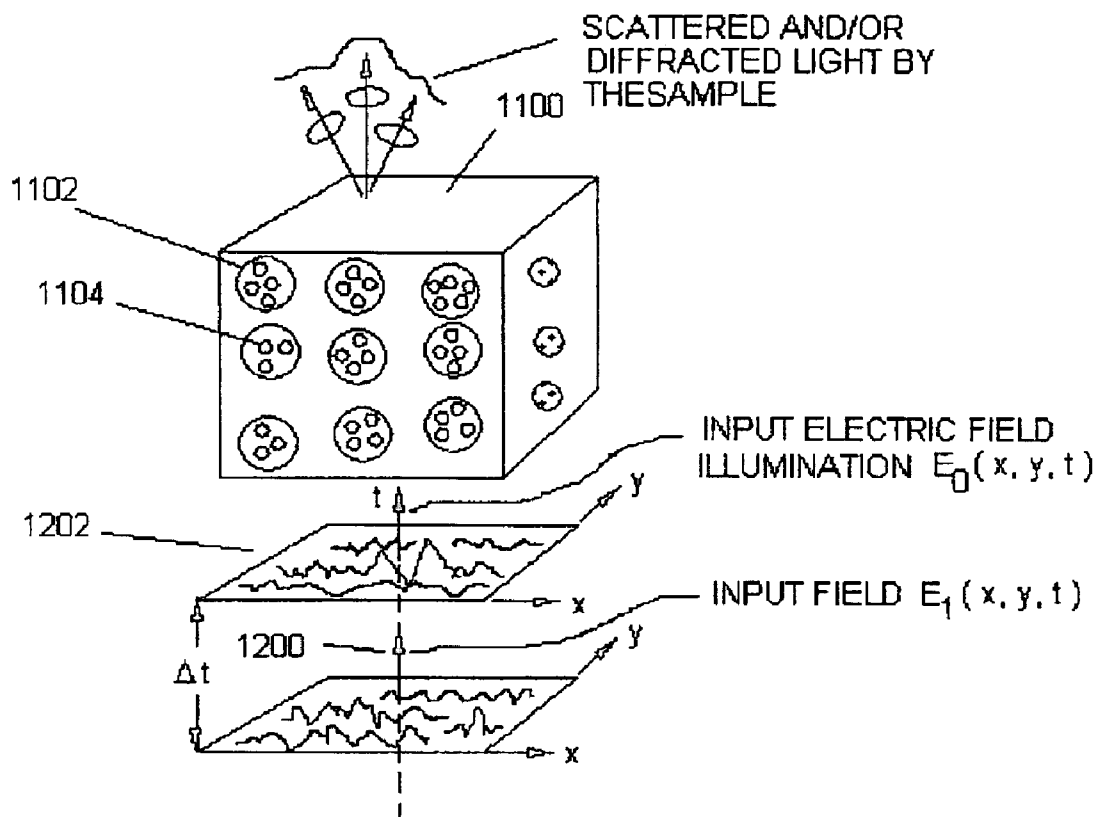

Figure 9



" Δt " must be large enough to acquire the optical phase of the scattered and/or diffracted light at the detector for each $E_n(x, y, t_n)$.

" $\Delta E_n(\Delta x_i, \Delta y_j, t_n)$ " must be less than d_{airy}/M

" $\Delta E_n(\Delta x_i, \Delta y_j, t_n)$ ", for all i and j within an object region

" d_{airy}/M " must have different coherent volumes.

Figure 10

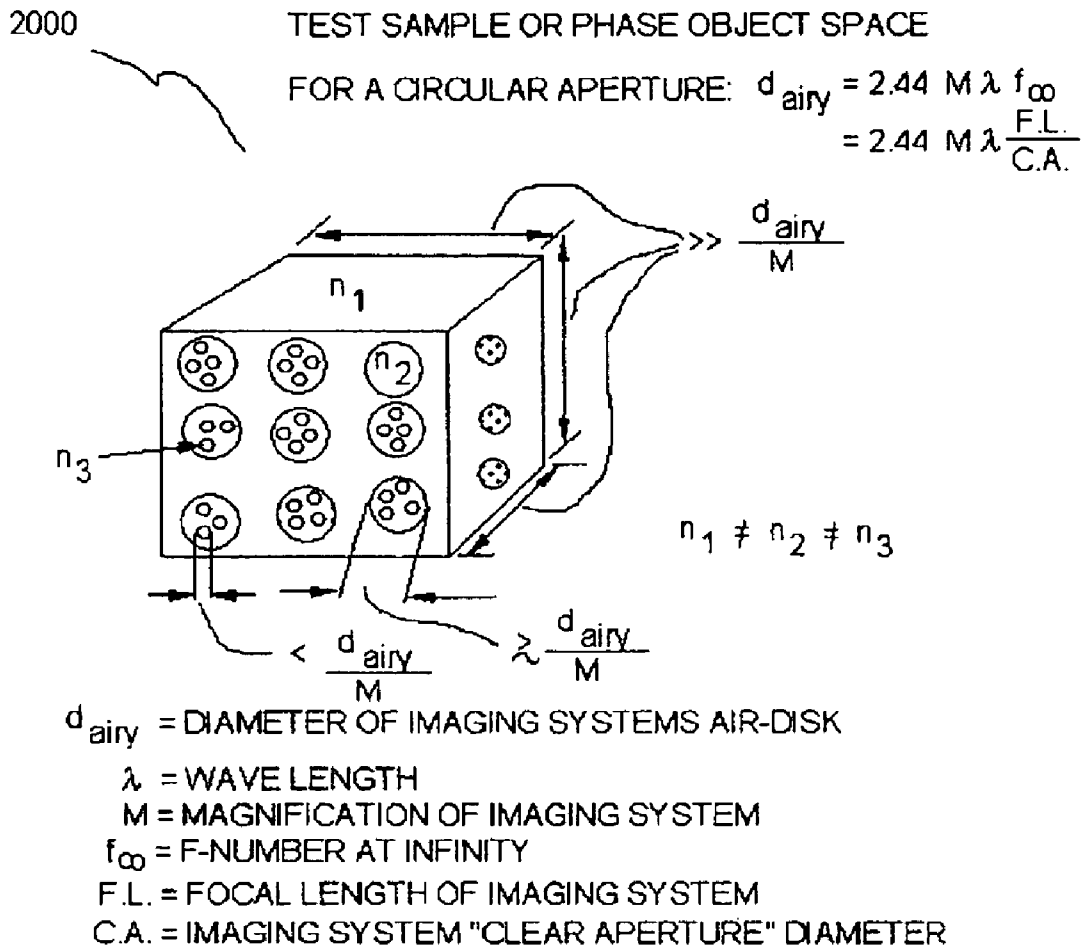

Figure 11

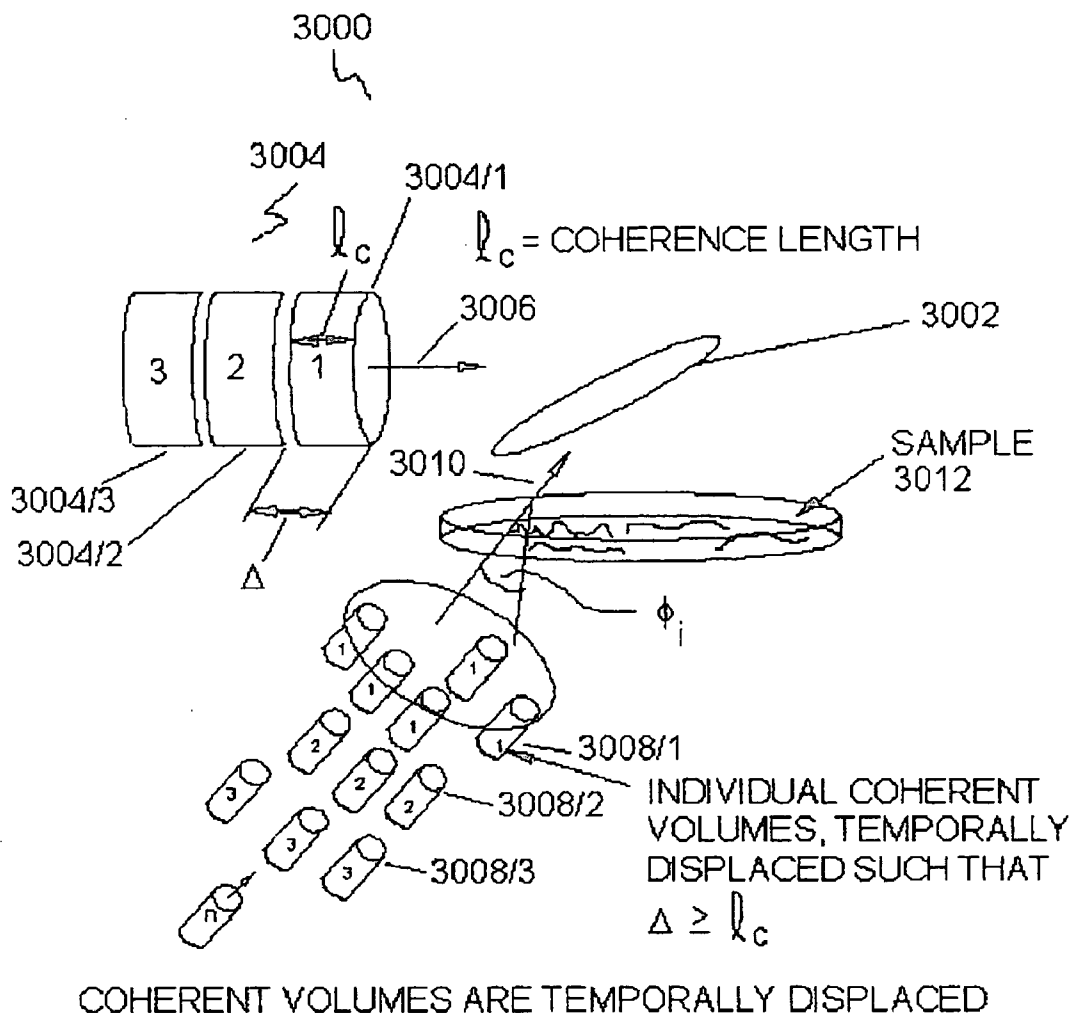

Figure 12

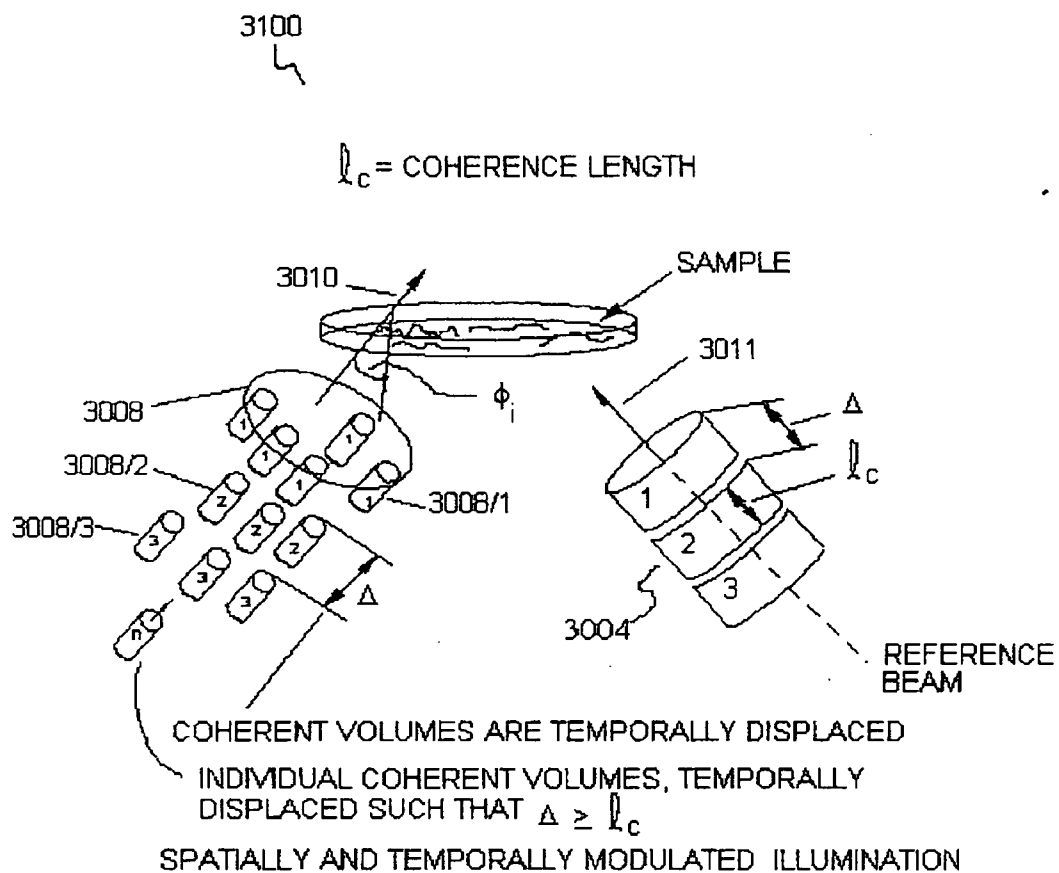
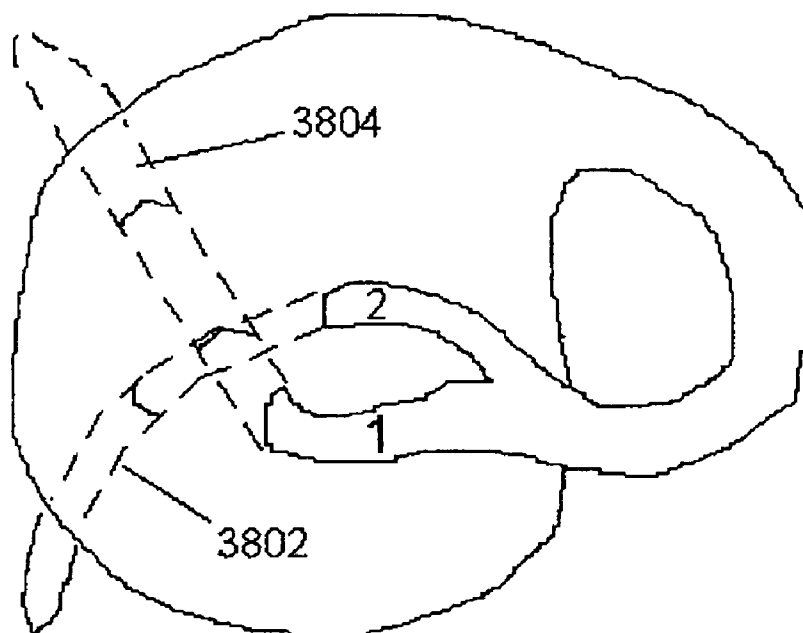

Figure 13

3800



OTHER COHERENT
VOLUME VARIATIONS



$n \geq 1$ COHERENT THREADS MAY
BE ADDED

Figure 14

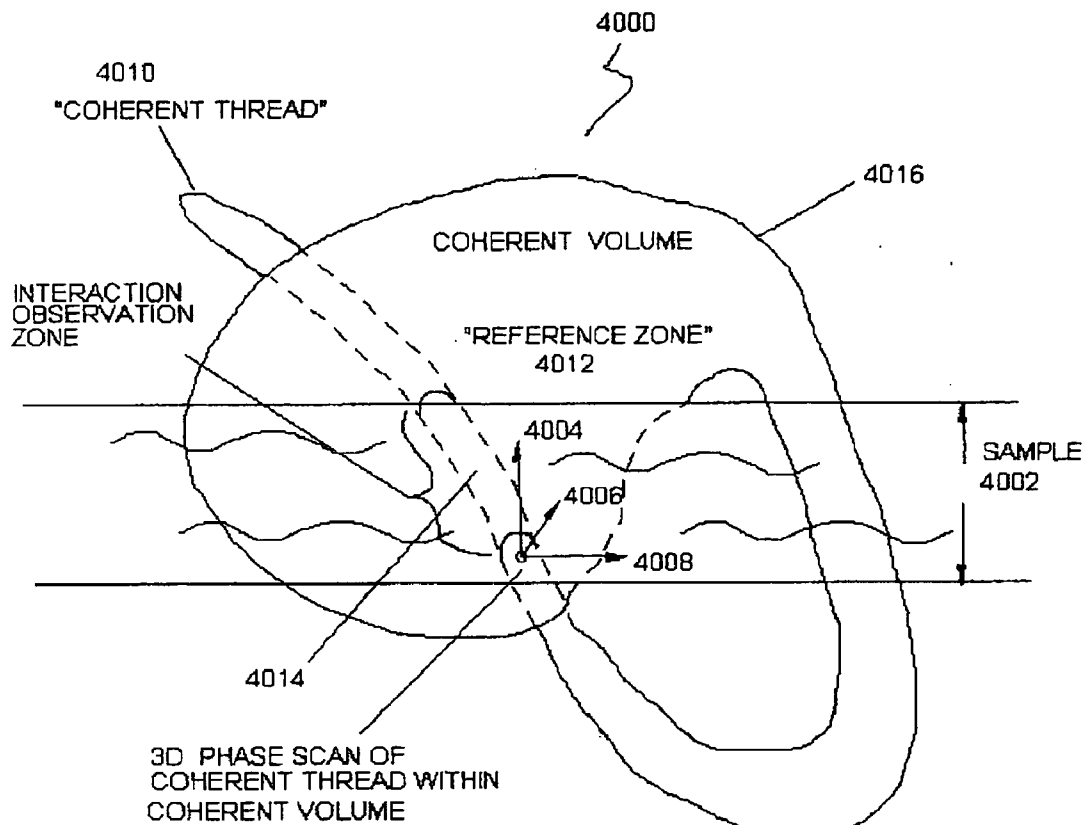

Figure 15

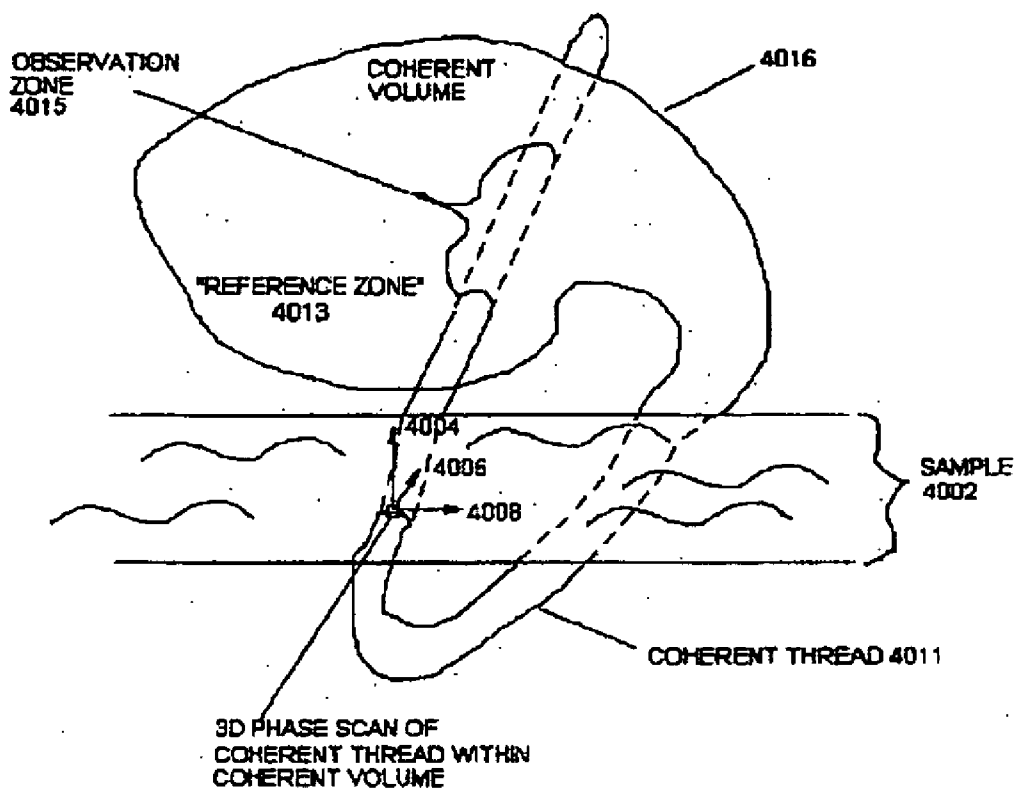

Figure 16

DIGITAL IMAGING ASSEMBLY & METHODS THEREOF

[0001] This application is a continuation-in-part of U.S. Non-Provisional application Ser. No. 10/983,053 filed Nov. 5, 2004, and claims the benefit of U.S. Provisional Application No. 60/518,918 filed Nov. 10, 2003, both herein incorporated by reference.

FIELD OF THE INVENTION

[0002] This invention relates in general to imaging systems, and more particularly to a coherent radiation imaging system that produces digital images with a reduced amount of speckle.

BACKGROUND OF THE INVENTION

[0003] In the field of imaging science, microscope designs have stayed fairly constant over time. A modern optical microscope has the same basic parts microscopes have had since their initial creation. A typical optical microscope includes the basic parts of a light source, a high power optical objective, a microscope body, and an eyepiece. The eyepiece is now commonly replaced with a focusing lens and photographic camera, or an electronic camera with an electronic area sensor. The electronic camera has been a major advancement insofar as the human eye and sketchpad needed for recording the images of the early microscopes have been replaced with electronic cameras and computer aided imaging analysis, which greatly enhance the users ability to analyze the magnified images.

[0004] Additional advancements have also taken place as to the light source, and particular with respect to the modern illuminator. Lasers, in conjunction with fluorescence markers, have significantly improved biologic microscopic imaging, for instance. Some of the most advanced systems involve some form of fluorescent spectroscopic imaging where laser energy is used as a narrow-band optical pump. A laser scanning confocal microscope is one such device.

[0005] For a modern microscope to be considered as performing well, high magnification, high contrast, and good resolution are generally needed. To attain these goals concurrently, a microscopic objective generally needs to have a large numerical-aperture (NA). This fact contributes to a basic limitation in most optical microscopes. Generally, providing a large NA is done at the expense of reducing the operational focus range or depth-of-focus (DOF).

[0006] Visualizing a lens as an interferometer can help put the effect of a large NA into perspective. Essentially, large NA optical systems capture highly diffracted object-generated photons with a lot of spatial information. Diffraction is fundamentally a quantum uncertainty process where the more a photon becomes localized by an object particle the more its position becomes uncertain. Capturing and understanding more of a photon's diffracted information better defines the object that caused the photon to diffract in the first place. Additionally, the more a photon is localized by a particle, and consequently diffracted, the less coherent it becomes with its neighbor photons that are not so highly localized or diffracted.

[0007] Given that contrast is a function of coherence, in large NA systems out-of-focus image features will tend to blur because over a given optical statistical average, there is

a higher ratio of collected incoherent to collected coherent photons. In essence, as a system steps more out-of-focus the statistical average of coherent photons is increasingly overwhelmed by incoherent photons, which leads to a fall off in contrast. Put another way, as NA becomes larger, contrast and associated image quality degrade more with focus error. The out-of-focus blurriness in a large NA optical system is greater than an optical system with the same magnification but with a smaller NA.

[0008] In short, high magnification large NA microscopes tend to have a very small DOF. Given that microbiologic materials exist and function in three-dimensional (3D) space, using large NA microscopes can prove less than satisfactory. As a result, much has been invested recently, in both effort and money, to better image biological materials in 3D.

[0009] Part of the problem is fundamental to what a geometrical optical system does with broadband light (i.e., white light). Glass optics work well by combining a few glass types, with simple spherical surface geometries for example, and can create a relatively high quality imaging system that instantaneously and statistically integrates trillions upon trillions of diffracted photons of many different energies, and doing so substantially in-phase to within a small fraction of a wavelength in many instances. For intensity based imaging (which most imaging is), this process of statistical averaging works well. However, if one is interested in capturing the true phase of the photons that enter the imaging system, this method can be totally unsatisfactory.

[0010] Phase is a key but under utilized property of light. Knowing the relative phase distribution (spatially and temporally) of coherently diffracted photons can provide direct knowledge of an object's existence in four-dimensional space (three spatial dimensions and one time dimension), for instance.

[0011] Currently, one of the best high magnification, commercial microscopic systems is a high-speed laser scanning, near-IR (NIR) 2-photon absorption confocal microscope, with a fast z-scanning (DOF scanning) platform or objective. This system uses 2-photon absorption fluorescent imaging to reduce background noise. This system tends to be very expensive, currently costing more than \$100,000 per unit for example. Other microscope technologies (research grade) are exploring the use of ultra-wideband-light and near-field imaging to greatly enhance resolution. More sophisticated models can currently sell for up to \$1,000,000 per unit for example.

[0012] Of these types of systems, none preserve the phase information of the light that is used in the imaging process. Traditionally, one needs sufficient time to measure the phase information, which is generally considered as requiring the use of long coherence illumination sources like a highly stabilized mode-locked laser. Here, the laser is used for direct illumination, unlike fluorescent imaging where a laser excites a secondary incoherent light source. With a long coherence illumination source, interferometric and holographic imaging are theoretically possible. However, such illumination will often result in poor image quality. Lasers, though great at enabling the determination of the phase information, can produce very poor image quality because

of specular noise (typically referred to as speckle), as illustrated by the problems identified in several patents cited below.

[0013] As is known to those skilled in the art, speckle is a phenomenon in which the scattering of light from a highly coherent source (such as a laser) by a rough surface or inhomogeneous medium generates a random intensity distribution of light that gives the surface or medium a granular appearance. Reference may be had, e.g., to page 1989 of the McGraw-Hill Dictionary of Scientific and Technical Terms, Sixth Edition (McGraw-Hill Book Company, New York, N.Y., 2003). Reference also may be had, e.g., to U.S. Pat. No. 6,587,194, the entire disclosure of which is hereby incorporated by reference into this specification.

[0014] As disclosed in U.S. Pat. No. 6,587,194 a comprehensive description of speckle phenomena can be found in T. S. McKechnie, Speckle Reduction, in Topics in Applied Physics, Laser Speckle and Related Phenomena, 123 (J. C. Dainty ed., 2d ed., 1984) (hereinafter McKechnie). As discussed in the McKechnie article, speckle reduction may be achieved through reduction in the temporal coherence or the spatial coherence of the laser light. There have been various other attempts over the years to reduce or eliminate speckle. Another article, B. Dingel et al., "Speckle reduction with virtual incoherent laser illumination using a modified fiber array," *Optik* 94, at 132 (1993) (hereinafter Dingel), mentions several methods for reducing speckle on a time integration basis, as well as based on statistical ensemble integration.

[0015] By way of further illustration, the speckle phenomenon is described at page 356 of Joseph W. Goodman's "Statistical Optics" (John Wiley & Sons, New York, N.Y., 1985), wherein it is disclosed that: "Methods for suppressing the effects of speckle in coherent imaging have been studied, but no general solution that eliminates speckle while maintaining perfect coherence and preserving image detail down to the diffraction limit of the imaging system has been found." The present invention reduces or effectively eliminates the effects of speckle while substantially preserving image detail.

[0016] The amount of speckle in an image may be measured in accordance with the equation set forth at page 355 of the aforementioned Goodman text (see equation 7.5-14), i.e.,

$$\zeta(v_u, v_v) = \langle I_i \rangle^2 \left[\delta(v_u, v_v) + (\bar{\lambda} \cdot z_2)^2 \int_{-\infty}^{\infty} \int_{-\infty}^{\infty} \left| \hat{P}(x - \bar{\lambda} \cdot z_2 v_u, y - \bar{\lambda} \cdot z_2 v_v) \right|^2 dx \cdot dy \right]$$

Reference also may be had, e.g., to U.S. Pat. No. 5,763,789.

[0017] Devices or systems for measuring phase are known. Reference may be had, e.g., to U.S. Pat. Nos. 5,541,608; 5,225,668; 4,012,689; 5,037,202; 5,789,829; 6,630,833; 3,764,897, and the like. The entire disclosure of each of these United States patents is hereby incorporated by reference into this specification.

[0018] As is known to those skilled in the art, there are many companies who perform analytical services that may

be utilized in making some or all of the measurements described in this specification. Thus, for example Wavefront Sciences Company of 14810 Central Avenue, S.E., Albuquerque, N. Mex. provides services including "simultaneous measurement of intensity and phase."

[0019] Alternatively, or additionally analytical devices that are commercially available such as, e.g., the "New View 200" interferometer available from the Zygo corporation of Middlefield, Conn.

[0020] Speckle exists in incoherent imaging as well, but over the statistical block of time that an image is formed, specular artifacts are effectively averaged away. This happens very quickly, on the order of femto-seconds. However, with statistical elimination of speckle, phase information is lost as well in these incoherent imaging systems.

[0021] What the present inventors have realized is the desirability of a system providing time to measure the point-to-point imaged optical phase, before the phase information is lost, while in the process, providing sufficient statistical information, whereby speckle is no longer an issue.

[0022] U.S. Pat. No. 5,361,131 of Tekemori et al. discloses and claims: "An optical displacement measuring apparatus for optically measuring a displacement amount of an object, comprising: image forming means for forming at least a first image indicative of a position of an object at a first time instant and a second image indicative of a position of the object at a second time instant; first modulating means for receiving at least the first and second images and for modulating coherent light in accordance with the first and second images, a relative position between the first image and the second image representing a displacement amount of the object achieved between the first time instant and the second time instant; first Fourier transform means for subjecting the coherent light modulated by said first modulating means to Fourier transformation to thereby form a first Fourier image; second modulating means for receiving the first Fourier image and for modulating coherent light in accordance with the first Fourier image; second Fourier transform means for subjecting the coherent light modulated by said second modulating means to Fourier transformation to thereby form a second Fourier image; detecting means for detecting a position of the second Fourier image which is indicative of the displacement amount of the object attained between the first and second time instants, said detecting means including a position sensitive light detector for receiving the second Fourier image and for directly detecting the position of the second Fourier image; and time interval adjusting means for adjusting a time interval defined between the first and second time instants, said time interval adjusting means adjusting the value of the time interval so as to cause the second Fourier image to be received by the position sensitive light detector."

[0023] The Tekemori et al. patent does not disclose its device as being capable of eliminating specular noise in an image. The present invention can provide a digital image with a reduced amount of speckle.

SUMMARY OF THE INVENTION

[0024] The method of embodiments of the present invention involves a process of controlled statistical processing,

where speckle noise can be effectively eliminated while preserving object phase. In summary, a process is employed where dynamic phase information is encoded onto the illuminating coherent beam, and measured, before input coherence is lost. Given the current availability of very stable and long coherence length lasers (with line widths on the order of 1 kHz), high-speed imaging, and high-speed phase processing; the realization of phase-controlled statistics is possible using embodiments of the present invention.

[0025] In the method of embodiments of the present invention radiation from a long coherence length source is used to form an image of a sample. The output coherent wave is temporally divided into a plurality of wavelets within one coherence length. The spatial phase of each wavelet is then modulated with a spatial phase modulator. The spatial phase of each wavelet is modulated a different and known amount. Each phase modulated wavelet illuminates the sample and is perturbed by its interaction with the sample. A spatial phase mapping of each perturbed wavelet is then measured and the resulting data is converted to an image of the sample by a computer programmed with an image reconstruction algorithm. The plurality of images thus formed is statistically averaged to form a final image. The high frequency speckle, which is not optically resolvable, tends to average to zero with continual statistical averaging, leaving only the optically resolvable lower frequency phase information.

[0026] One microscope embodiment of this invention complete phase and amplitude information is preserved, allowing one to observe objects in three-dimensional space, and to recreate and scale imaged samples using computer readable digital holograms.

[0027] In another embodiment, the present invention allows one to achieve phase contrast edge enhancement. In one aspect of this embodiment, one utilizes object slices of a biological structure that are mostly suspended in an aqueous environment. In this aspect, light tends to go through (in transmission), occasionally being scattered and diffracted, with little absorption. This essentially describes a phase object. This is one of the reasons fluorescent dye markers are so popular with these objects in that they absorb a lot of light and, thus, render them easier to see. Phase contrast, on the other hand, uses small shifts in relative optical phase (which is on the order of a fraction of a wavelength) to see features of the object. This results in a much more sensitive and less imposing way to see things compared to absorptive imaging, which requires a foreign contrast agent to be applied; the foreign contrast agent often does harm to the biological sample.

[0028] In another embodiment, non-destructive cellular interaction (in vivo) is achieved; thus, no fluorescent dyes or markers are required. Secondary organic or inorganic marking components, added to enhance imaging, can and do interfere or change certain biological processes, and in a worse-case scenario, kills the biological sample under investigation via optical bleaching, for instance.

[0029] In another embodiment, the present invention allows one to achieve high-speed imaging for observing biological processes in real time; thus, e.g., one may observe cellular, dynamic processes, in digital form, to enable automated analytics.

[0030] In another embodiment, the present invention allows one to obtain less than 0.1 micron imaging resolution

(less than the Raleigh defined resolution limit) using low energy photons (such as, e.g., photons in the visible range between 700 and 400 nanometers). One microscope in accordance with an embodiment of the present invention includes a resolution system that obtains a resolution down to 50 nanometers.

[0031] This microscope utilizes the phase of the light which is determined opto-electronically, in discrete coherent steps. After a coherent step, the optical statistics are changed in a highly controlled and pre-determined fashion and the phase is determined again. This is done repeatedly until one has attained enough information to remove speckle. By controlling the optical statistics in time, one can build up a quality image without the limitations of other optical microscopes.

[0032] Today, there are limitations to what can be done with optical microscopic imaging; these limitations are created, at least in part, due to the material limitations of glass optics. Producing large NA objectives is very difficult, and industry is now pushing the limits of glass technology. With the approach disclosed herein, individual optical systems can be brought together, and in-phase. This is made possible by combining optics, electronics, and computing in new ways as disclosed herein.

[0033] Microscopes disclosed in this text will allow direct and in situ visuals of three-dimensional interacting proteins and internal cellular dynamics in their natural state. Additionally, this technology can be extended to other medical imaging devices as well, such as endoscopes.

[0034] This invention enables new detailed imaging of live cells and will provide new insights into how both healthy and diseased cells function, and how cellular signaling and transduction works.

[0035] Currently, it is not possible to optically observe a living cell, while in its natural state, and observe the 4-dimensional (space and time) dynamic biological processes that the cell performs. Many processes, such as DNA activity, are assumed or inferred with static observational fragments and simulated models. For instance, DNA analysis using X-ray crystallography requires first killing the cell. PCR and other activities require removing the DNA from the cell and adding chemicals to it.

[0036] The limitations of current optical microscopes as described above are not present in the herein disclosed microscope.

BRIEF DESCRIPTION OF THE DRAWINGS

[0037] The invention will be described by reference to the following drawings, in which like numerals refer to like or similar elements, and in which:

[0038] **FIG. 1** is a flow diagram of an exemplary embodiment of a method in accordance with the invention;

[0039] **FIG. 2A** is a schematic component diagram of a coherent light source system in accordance with embodiments of the invention;

[0040] **FIG. 2B** is a schematic diagram of an acousto-optic phase modulator in accordance with embodiments of the invention;

[0041] FIG. 3 is a schematic component diagram of a microscope in accordance with embodiments of the invention;

[0042] FIG. 4A is a schematic component diagram of a microscope with indirect illumination of the sample in accordance with embodiments of the invention;

[0043] FIG. 4B is a schematic diagram further illustrating the indirect sample illumination;

[0044] FIG. 4C is a schematic diagram of a multiple diffraction grating coupler;

[0045] FIG. 5 is a schematic component diagram of a microscope with a sample stimulator in accordance with embodiments of the invention;

[0046] FIG. 6 is a schematic component diagram of a microscope with multiple digital cameras in accordance with embodiments of the invention;

[0047] FIG. 7 is a schematic component diagram of a microscope connected to a communications network in accordance with embodiments of the invention;

[0048] FIG. 8 is a block diagram of a lens in a detection system for use in an optical microscope in accordance with embodiments of the present invention;

[0049] FIG. 9 is a perspective diagram of a sample with resolvable subcellular units and non-resolvable subcellular units;

[0050] FIG. 10 is a perspective diagram of an interaction of an electrical field with a sample;

[0051] FIG. 11 is a perspective diagram of a test sample for testing embodiments of the present invention;

[0052] FIG. 12 is a perspective diagram of coherent light from a coherent light source passing through a sample with a reference beam traveling in a first direction;

[0053] FIG. 13 is a perspective diagram of coherent light from a coherent light source passing through a sample with a reference beam traveling in a second direction;

[0054] FIG. 14 is a diagram of a scan of a three-dimensional sample using multiple coherent threads with a reference zone in the sample;

[0055] FIG. 15 is a diagram of a scan of a three-dimensional sample in three axes; and

[0056] FIG. 16 is a diagram of a scan of a three-dimensional sample using multiple coherent threads with a reference zone outside the sample.

DETAILED DESCRIPTION OF EXEMPLARY EMBODIMENTS OF THE INVENTION

[0057] The present invention will now be described with reference to exemplary embodiments to which it is not limited. Variations and modifications will occur to skilled artisans which are encompassed within the present invention as defined in the claims appended hereto.

[0058] FIG. 1 is a block diagram illustrating an exemplary method in accordance with the present invention. A source of coherent radiation **10** provides the coherent wave **11** of radiation to be used to image the sample **18**. As used in this specification, the term “coherent radiation” means electro-

magnetic radiation of the same, or almost the same, wavelength, and with definite phase relationships between different points in the field. See, e.g., page 423 of the “McGraw-Hill Dictionary of Scientific and Technical Terms,” Sixth Edition (New York, N.Y., 2003). Reference may also be had, e.g., to U.S. Pat. Nos. 6,272,095, 6,094,300, 6,055,044, 6,002,499, 5,963,626, 5,754,511, and the like. The entire disclosure of each of these United States patents is hereby incorporated by reference into this specification.

[0059] The processes embodied in the present invention are not limited to a specific wavelength range of the coherent radiation. At one time the word “light” referred only to the visible spectrum, roughly from 400 nm to 700 nm, but advances in both short-wave and long-wave sensor and optical materials have altered this convention to be much more inclusive. The words “optics” and “light” will be used extensively in this specification but should not be inferred to imply a specific wavelength range. Recently electromagnetic radiation (i.e., light) in the range of 30 to 1000 μm has shown promise for useful applications.

[0060] As is known to those skilled in the art, there are two measures of coherence: temporal coherence, and spatial coherence. As is disclosed at page 157 of Joseph W. Goodman’s “Statistical Optics” (John Wiley & Sons, New York, N.Y., 1985), “. . . it is . . . worth briefly mentioning the distinction between two types of coherence, temporal coherence and spatial coherence. When considering temporal coherence, we are concerned with the ability of a light beam to interfere with a delayed (but not spatially shifted) portion of itself. We refer to such portioning of a light beam as amplitude splitting. On the other hand, when considering spatial coherence we are concerned with the ability of a light beam to interfere with a spatially shifted (but not delayed) portion of itself. We refer to this type of portioning of light as wavefront splitting.

[0061] Many United States patents discuss these types of coherence. For a discussion of temporal interference, reference may be had, e.g., to U.S. Pat. No. 5,469,261 (measurement of lens characteristics), U.S. Pat. No. 4,936,665 (high-resolution imagery systems and methods), U.S. Pat. No. 4,869,593 (interferometric surface profiler), U.S. Pat. No. 4,831,629 (incoherent, optically coupled laser arrays), U.S. Pat. No. 6,577,429 (laser projection display system), and the like. The disclosure of each of these United States patents is hereby incorporated by reference into this specification.

[0062] If a wave is combined with a delayed copy of itself, the duration of the delay over which it produces visible interference is known as the “coherence time”, Δt . From this, a corresponding “coherence length” can be calculated as $\Delta l = c\Delta t$, where c is the speed of the wave. See, e.g., page 423 of the “McGraw-Hill Dictionary of Scientific and Technical Terms,” Sixth Edition (New York, N.Y., 2003).

[0063] In order for this coherent speckle mitigation process to work, a highly coherent light is required. Just how much illumination coherence that is required will (primarily) depend on the phase measuring camera frame rate, assuming that capturing a frame will be slower than all other temporal processes. As an example, assume that at least 20 controlled statistical averages are performed over the coherence time. Given a laser with a 1 kHz line-width, the coherence time is: $\tau_c = (1 \cdot \text{kHz})^{-1} = 1 \cdot \text{ms}$, which gives a coherence length of:

$\lambda_c = c \tau_c = 300$ km. Hence, the camera needs a minimum capture frame rate of: $FR = 20/\tau_c = 20,000$ fps. Such cameras are currently available by various companies.

[0064] For a discussion of spatial coherence, reference may be had, e.g., to U.S. Pat. No. 5,923,425 (grazing incidence interferometry), U.S. Pat. No. 5,534,970 (scanning exposure device), U.S. Pat. Nos. 4,420,218, 4,936,665, 4,732,483 (interferometric surface profiler), U.S. Pat. No. 4,396,289, and the like. The entire disclosure of each of these United States patents is hereby incorporated by reference into this specification.

[0065] Many coherent light sources are described in the United States patent literature. Reference may be had, e.g., to U.S. Pat. Nos. 5,321,718, 5,309,907, 6,424,449, 5,978,109, 5,596,409, 4,142,773, 6,480,272, 4,921,352, and the like. The disclosure of each of these United States patents is hereby incorporated by reference into this specification.

[0066] As is well known to those skilled in the art, coherent light sources are readily commercially available. Thus, and referring to the 1999 Melles Griot catalog (published by Melles Griot Inc.) for instance, one may use a "Stabilized Helium Neon Laser Systems for Research" assembly that is discussed on page 44.11 of such catalog. In one embodiment, the coherent source **10** in **FIG. 1** is a laser light source that is capable of operating in a single longitudinal mode, and in a single transverse mode.

[0067] Referring again to **FIG. 1**, in an exemplary method of the present invention, in the step represented by block **12**, the radiation from source **10** is temporally divided into a plurality of wavelets **13** within one coherence time Δt , each wavelet occupying a sequential time interval δt which is a fraction of the coherence time Δt . In the step represented by block **14**, the spatial phase of each wavelet **13** is modulated a different and known amount by a spatial phase modulator.

[0068] **FIG. 2A** is a schematic component illustration of one physical embodiment for implementing blocks **10-14** of **FIG. 1**. A laser **302** is used as the coherent radiation source. Laser **302** is such that it has a sufficiently large coherence volume such that the phase can be determined for a minimum resolvable object element as defined by the optical elements of the device. The laser-generated light **11** is fed into a delay line **306** by the input component **308**. The input component **308** is an electronically controlled fiber optical coupler. The delay line **306** is long optical fiber line (race-track), where coherence, phase, and polarization information are preserved. Reference may be had, e.g., to the website on the World Wide Web at ozoptics.com for a description of some of these components. The delay line **306** comprises an optical pump **310** to compensate for optical losses. Such optical pumps are well known to those skilled in the arts.

[0069] Referring again to **FIG. 2A**, the bleed off electronically controlled coupling component **312** channels a portion of the light from the delay line **306** directly into a collimation lens **318**, or optionally into a wavelength up-converter **316** and then to the lens **318**, via optical line **314**. A wavelength up-converter **316** usually is a nonlinear crystal, well known to those skilled in the art, whereby the wavelength can be reduced.

[0070] The light leaving the collimation lens **318** is either reflected or transmitted through a spatial phase modulator **320**, which can accurately adjust the phase by $X \cdot \lambda (\Delta x, \Delta y)$,

where $X \geq 0$, as compared to a reference. In one embodiment of the present invention the spatial phase modulator is a rotatable planar reflector which imparts different phase tilts to the illumination beam before interaction with the sample. In general, other forms of wavefront encoding are possible, not just phase-tilts. However, given the Fourier mathematical analogy that all waveforms may be synthetically and uniquely generated by an infinite series of tilted, and phase shifted, plane waves of various amplitudes, the proposed processes are quite general. In a broader sense, the process being described here is precisely this, as long as all the phase encoded elements are applied within the spatial and temporal coherence volume of the coherent illuminator. Phase encoded illumination can be used to extend the depth of focus imaging given that various waveforms can be synthesized with the above phase process, throughout the object volume. Imaged depth-of-field displaced phase objects are not invariant with different phase illuminations; hence, object depth information can be uniquely computed.

[0071] The spatial phase modulator **320** could alternatively be a device such as a mechanical (MEMS) device, an electro-optical (liquid crystal, acousto-optical, etc.) device, or combination device. **FIG. 2B** is a schematic illustration of an acousto-optic embodiment of a phase modulator. In the embodiment depicted in **FIG. 2A** the light leaving spatial phase modulator **320** is designated by numeral **15** as it is the same as phase modulated wavelet **15** in **FIG. 1**.

[0072] Referring again to **FIG. 1**, illumination optics **16** illuminate sample **18** with the phase modulated wavelet **15**. The illumination optics **16** can be a grating, prism, lens, or some other pre-determined optical phase input device, such that the phase information encoded by spatial modulator **320** and delay line (components **308**, **310**, **306**, and **312**) is maintained. Phase modulated wavelet **15** interacts with sample **18** and is thereby transformed into perturbed wavelet **19**. The perturbed wavelet is then directed by collection optics **20** through high speed shutter **22** to the spatial phase measurement system **24** which extracts the perturbed phase information from perturbed wavelet **19** to produce phase reconstructed wavelet **25** by opening the shutter once for each wavelet. Reconstructed wavelet **25** is detected by high speed optical sensors **26** which produce a spatial phase mapping of the reconstructed wavelet **25**. An image reconstruction program **28** then converts the spatial phase mapping from sensors **26** into an image of the sample **18** once per wavelet. At this point the image formed from a single wavelet still contains high frequency specular noise (speckle). To reduce the speckle the plurality of images from all of the wavelets are added and averaged by statistical averaging program **30** to produce the final image **32**. This is done, for instance, by summing the value of each pixel from each wavelet image and dividing the result by the number of wavelet images. The high frequency speckle which is not optically resolvable tends to average to zero with continual statistical averaging, leaving only the optically resolvable lower frequency phase information, thereby producing a final averaged image with significantly reduced speckle.

[0073] **FIG. 3** is a schematic diagram of the components of a microscope **100** to carry out the exemplary method of the present invention described above. In **FIG. 3** source **110** represents the components, illustrated as blocks **10-14** in **FIG. 1**, which produce phase modulated wavelets **15**. Source **110** is connected to a programmable logic unit (PLU)

150 via communication line **154**, although other communication systems and methods can be used.

[0074] In one embodiment, PLU **150** is, e.g., a programmable computer with multiple communication ports, display unit(s), data storage devices (e.g. RAM, ROM, or other memory storage devices), input device (e.g. a keyboard, a mouse, or other input devices), and the like. Nearly any computing device capable of carrying out the appropriate processing, whether analog or digital could be used.

[0075] As used in this specification, the term “communication line” refers to any number of systems and methods for enabling the conveyance of information between two or more components. Such systems and methods include, but are not limited to, fiber optical cable, conductive wire and wireless links and the like, together with the necessary transducers at each component for sending and receiving the information.

[0076] Phase modulated wavelet **15** is directed to sample holder **120** via illumination optics **16** where it is scattered and/or diffracted by features of the sample to become perturbed wavelet **19**. Perturbed wavelet passes through a lens **126** and objective **128**. In the embodiment depicted, the objective **128** is connected to a high-speed shutter **132**. The high-speed shutter **132** is connected to the PLU **150** via communication line **153**. A controlled phase unit **134** is connected to the high-speed shutter **132**. Controlled phase unit **134**, which is connected to and controlled by PLU **150** via communication line **152**, corresponds to spatial phase measurement system **24** in FIG. 1, whereby it extracts the phase information from perturbed wavelet **19** to produce reconstructed wavelet **25**.

[0077] Controlled phase unit **134**, controlled by PLU **150**, may be used, for example, to effectuate the process described in U.S. Pat. No. 6,545,790; the entire disclosure of this United States patent is hereby incorporated by reference into this specification. This patent describes and claims: “A method for recovering information from a wave front corresponding to a substantially monochromatic coherent radiation, comprising: (a) irradiating a specimen of material with the substantially monochromatic coherent radiation, the specimen being positioned in a first plane; (b) filtering radiation modulated by the specimen according to N predetermined filtering patterns corresponding to one or more filters, wherein said one or more filters are positioned substantially in the first plane; (c) for each of the N filtering patterns, capturing spatial intensity values for the filtered modulated radiation at a second plane to produce N corresponding intensity distributions, wherein the second plane is a conjugate diffraction plane with respect to the first plane; (d) processing the N intensity distributions captured in the second plane to provide an estimate of the wave front at the first plane, the step of processing comprising correcting the effect of the corresponding filtering patterns; (e) filtering the provided wave front estimate using the N different filtering patterns to obtain N filtered estimates; (f) processing the filtered estimates to produce N estimated intensity distributions at the second plane; and (g) repeating steps (d), (e) and (f) until an error measure associated with the captured and the estimated intensity distributions in the second plane reaches a predetermined threshold.”

[0078] The controlled phase unit **134**, controlled by PLU **150**, may alternatively be used to effectuate the process of

U.S. Pat. No. 6,369,932, the entire disclosure of which is hereby incorporated by reference into this specification. This patent describes and claims: “1. A method for recovering phase information of a wave front of a substantially monochromatic coherent waveform comprising: (a) providing a lens having an associated back focal plane (BFP) and image plane (IP); (b) passing the wave front through the lens and through a phase filter disposed at the BFP of the lens, the phase filter imparting known phase shifts to the wave front; (c) recording spatial intensity values for the wave front at the IP; (d) repeating steps (b) and (c) N-1 times for different values of the imparted phase shifts to obtain N intensity images of the wave front at the IP; (e) associating phase values for each of the N intensity images of the wave front to form N synthetic wave front images; (f) processing the N synthetic wave front images to obtain a single estimate of the wave front at the BFP; (g) generating modified N synthetic wave front images based on the recorded spatial intensity values for each image, on the estimate of the wave front at the BFP and on the corresponding phase shifts; and (h) repeating the process in steps (f) and (g) until an error measure associated with the N synthetic wave front images reaches a predetermined value.”

[0079] One may use any of the spatial modulators known to those skilled in the art for the controlled phase unit **134** or variations thereof. Reference may be had, e.g., to U.S. Pat. Nos. 6,624,756; 6,567,163; 6,563,167; 6,552,777; 6,538,800; 6,538,791; 6,430,328, and the like. The entire disclosure of each of these United States patents is hereby incorporated by reference into this specification. The phase measurement processes disclosed in the Gershberg U.S. Pat. Nos. 6,365,932 and 6,545,790 are just two examples of implementing the spatial phase measurement block **24** in FIG. 1. Other processes, e.g. Mickelson interferometry, will be apparent to those skilled in the art.

[0080] Referring again to FIG. 3, digital camera **142** is connected to controlled phase unit **134**. Digital camera **142**, which is connected to PLU **150** via communication line **146**, captures reconstructed wavelet **25** and produces a phase mapping of reconstructed wavelet **25**. PLU **150** is additionally programmed with an image reconstruction program that converts the wavelet **25** phase mapping, captured by digital camera **142**, into an image of sample **122**, such as disclosed in the Gershberg patents mentioned in the preceding paragraph. PLU **150** is additionally programmed to form such images of sample **122** for the plurality of wavelets created by source **110** within the coherence length of laser **302**. PLU **150** is additionally programmed to add and statistically average the plurality of images from all of the wavelets to produce a final image of sample **122**. Basically the speckle is caused by objects in the image space that cannot be resolved because of the practical limitations of the optical system e.g., those related to the S number and wavelength of the imaging light, the f-number and the NA. While these objects cannot be resolved in a given optical system, they create random signals on the imaging devices in the form of speckle. When this random noise is averaged over time, however, it tends to average toward zero, and by employing embodiments of the present invention the adverse effects of speckle are greatly mitigated. The high frequency speckle in the individual wavelet images, which is not optically resolvable, tends to average to zero with continual statistical averaging, leaving only the optically resolvable lower frequency phase information, thereby producing a final aver-

aged image with significantly reduced speckle. The final image is, e.g. a 2 dimensional image, a 3 dimensional image, a hologram, and/or the like.

[0081] Additionally, PLU 150 comprises devices for storing both the raw data received from the digital cameras 142 and 144 as well as devices for storing the reconstructed images. In one embodiment, PLU 150 comprises devices for transmitting the data and images to other storage devices and media, computers, computer and/or communication networks, and the like.

[0082] Digital camera 142 is, e.g. Andor's iXon87 Electron Multiplying CCD camera, or other high-speed digital camera. In one embodiment, the digital camera 142 has sufficient resolution that sampling is $\leq 25\%$ of the center lobe of the Point Spread Function (PFS) of the optical system. The camera speed should be $\geq TC$ (coherence tie) defined within the source-sample interaction region. The camera sensitivity, for a given sensor quantum efficiency and optical field amplitude, should be $> S/N$ (signal-to-noise ratio) of the entire imaging chain. The imaging chain includes: light capture \rightarrow statistical optical noise \rightarrow Sensor \rightarrow statistical sensor noise \rightarrow Digital conversion \rightarrow statistical electronic noise \rightarrow Algorithmic processing.

[0083] FIG. 4A is a schematic diagram of the components of a microscope 200 that is an alternate embodiment of microscope 100 in FIG. 3. Referring to FIG. 4A, the wavelet 15 from source 110 passes through a grating coupler 112 used to couple in the coherent wavelet 15 into an optical waveguide 116. As will be apparent, the function of the grating coupler 112 is to transport light into the sample 122. Other coupling devices, such as a prism (not shown), also may be used.

[0084] In the embodiment depicted in FIG. 4A, the wavelet 15 contacts diffraction grating 112 that couples the light so that some of it passes through the waveguide 116, and some of it passes down the length of the waveguide in a waveguide mode. A schematic depiction of this function is illustrated in FIG. 4B. As will be apparent from FIG. 4B, depending upon the sample and its properties, one can choose waveguide illumination devices that will be sufficient to illuminate the sample but will minimize light pollution.

[0085] As will be apparent from the accompanying Figures, and the discussion thereof, the waveguide illumination devices are chosen such that the phase information of the illuminating light is not changed in an undetermined way, thus producing data that cannot be analyzed. To that end the signal to noise ratio of the light detected by detector 125 (see FIG. 4B) is greater than about 1 and, in one embodiment, greater than about 2.

[0086] Referring again to FIG. 4A, the grating coupler 112 is a conventional grating coupler that is commercially available. Thus, by way of illustration and not limitation, one may use one or more of the grating couplers described in U.S. Pat. Nos. 5,218,584, 5,153,860, 5,070,488, 4,868,803, 5,363,226, 5,481,516, and the like. The entire disclosure of each of these United States patents is hereby incorporated by reference into this specification.

[0087] One embodiment of another grating coupler 712 is illustrated in FIG. 4C. Referring to FIG. 4C, it will be seen that coherent light rays 714, 716, 718, and 720 impact

diffraction gratings G3, G2, G4, and G1, respectively. Some of the light diffracted by these gratings passes through waveguide 722. The light waves coherently interact in the sample region 724 to form a controllable interference pattern; in this pattern, two dimensions in space, and time, are controlled. As will be apparent, other devices or systems producing the desired output may be used. Thus, e.g., one may use a waveguide 116 with one or more coupling regions.

[0088] Referring again to FIGS. 4A and 4B, the waveguide 116 is a planar waveguide that has good transmission characteristics for the illumination wavelength of interest. One may use, e.g., one or more of the planar waveguides described in the prior art such as, e.g., those planar waveguides described in the claims of U.S. Pat. Nos. 6,432,292, 6,215,928, 6,160,824, 5,485,277, 6,546,163, 5,365,243, and 4,961,618. The entire disclosure of each of these United States patents is hereby incorporated by reference into this specification.

[0089] In one embodiment, the waveguide 116 is made from an amorphous material (such as, e.g., glass) and/or crystalline material.

[0090] Referring again to FIGS. 4A and 4B, the coupled-in-coherent light 118 travels through the waveguide 116 to the sample holder 120 where it is scattered and/or diffracted by features of the sample to become perturbed wavelet 19.

[0091] The use a waveguide to direct the illuminating radiation onto the sample as in FIGS. 4A and 4B instead of directly as in FIG. 3 is a form of highly structured dark-field illumination or a kind of near-field-imaging. Evanescent waves, which are spatially connected to interfering modes within the waveguide cavity, extend beyond the waveguides surface and into a object sample that lays upon it. The object of interest will interact with these evanescent fields and side scatter the light energy into the microscope. In this way, interfering waves with features in a dense waveguide that are $< \lambda/2$ can resolve more object details that using a more direct illumination approach.

[0092] FIG. 5 is a component schematic of another embodiment of an optical microscope 250. In addition to the components described in the embodiment depicted in FIG. 3, and the accompanying descriptive text, optical microscope 250 comprises a sample-stimulating unit 202. Sample stimulating unit 202 emits stimulating signals 204 that strike the sample 122 in part or in whole. Stimulating signals 204 are, e.g. laser and/or other light waves, sound waves, electric fields, magnetic fields, a liquid stimulant, a gaseous stimulant, ion beams, electron beams and/or other sample stimulating devices. In another embodiment (not shown) sample stimulating devices may be included as part of sample holder 120 and may include one or more nano-probes, e.g. nano-tubes and the like which are used for simulation of the sample through mechanical contact with the sample 122. In another embodiment sample stimulation unit 202 further comprises sensing devices or systems for sensing physiological and/or other properties of the sample, e.g. temperature, surface membrane tension, gases given off by the sample 122, electromagnetic (including light) signals given off by the sample 122, the sample's shape, and the like. Observations of what happens in a living system can be made given a certain stimulus. Given the observed system is alive, adding a little controlled stimulus is effective for experimentation.

[0093] Referring again to FIG. 5, it will be seen that sample stimulation unit 202 is optionally connected to PLU 150 via communication line 206. In one embodiment, sample stimulation unit 202 is controlled by programmable algorithms in the PLU 150. In another embodiment sample stimulation unit 202 is controlled by programmable algorithms in the PLU 150, which are in part or in whole based on a timed sequence. In another embodiment, PLU 150 receives sensed data from the sample stimulation unit 202. In yet another embodiment, PLU 150 adjusts the stimulation of the sample 122 based on algorithms that sample the sensed data. In another embodiment, PLU 150 adjusts the stimulation of the sample 122 based on algorithms which sample the sensed data and which samples or otherwise interrogates a database. In yet another embodiment, the PLU 150 enables an operator (not shown) of the microscope 200 to adjust the sample stimulation unit's 202 parameters and functionality in real time.

[0094] In another embodiment, not shown in a figure, a sealed enclosure that encloses sample 122 in FIG. 3, 4A, or 5 is provided. In another embodiment, other components, in part or in whole, of the microscope are enclosed. In one embodiment the enclosure encloses all paths of the light through the microscope that would otherwise be open to normal atmospheric air. In another embodiment, the enclosure is used to hold a gas. In another embodiment, the enclosure is connected to vacuum pumps and is used to maintain a partial vacuum.

[0095] FIG. 6 is a component illustration of an optical microscope 400 with multiple digital cameras 420, 434, 448, 456, connected respectively to PLU 150 via communication lines 422, 436, 450, 458. Wavelet 19 is split and directed into each camera by beam splitters 410, 424, 438. The use of multiple digital cameras permits faster parallel processing of the perturbed wavelet phase information. This arrangement can also be used to algorithmically extract the imaged optical phase information of the sample via phase diversity, phase encoding, or other phase processes that are post-sample-light-interactive.

[0096] FIG. 7 is a component illustration of an optical microscope 600 with a bi-directional network communication system 606 to a remote computer system 604. In one embodiment, the PLU 602 transmits the raw image data to the remote computer system 604 that runs image construction software (not shown but see the Gerchberg and other image construction patents referenced above) to construct final images. Remote computer system 604 transmits the final images to the local PLU system 602 to be displayed to the local microscope operator. In one embodiment, remote computer system 604 stores both the raw image data collected and the constructed images in data storage media. In another embodiment, the remote computer system 604 comprises additional modeling software that receives the constructed images and produces a 3D Computer Aided Design or other computer model of the imaged sample. The remote computer system 604 transmits the 3D computer model to the local microscope PLU system 602 which can have additional software to display the received 3D computer model to the local microscope operator.

[0097] In another embodiment, not shown, a microscope like that of FIG. 3, 4A, 5, 6, or 7 has a robotic sample loader. In this embodiment, there is no local microscope operator. In

one embodiment the sample loader is controlled by a program in the PLU 602. In another embodiment the sample loader is controlled remotely by a computer program interface on the remote computer system 604 and a remote operator that issues commands through the computer program interface.

[0098] FIG. 8 et seq. schematically illustrates one of the problems that is capable of being solved by the presently disclosed process and apparatus.

[0099] An Airy disc is the central peak (including everything interior to the first zero or dark ring) of the focal diffraction pattern of a uniformly irradiated, aberration-free circular optical element or system. Reference may be had, e.g., to U.S. Pat. Nos. 6,385,157, 5,612,818, 5,457,533, 5,392,271, 4,975,237, and the like. The entire disclosure of these United States patents is hereby incorporated by reference into this specification. FIG. 8 illustrates a lens 1000 through which plane waves 1002 are transmitted. It is preferred that the lens 1000 be diffraction limited, thereby producing an Airy disc. This idealized situation is illustrated in FIG. 8. In general, the point spread function of the imaging system is equal to or larger than the diameter of the Airy disc. The diameter of the Airy disc is given in FIG. 8, by reference the equation presented therein.

[0100] In the remainder of the discussion in this section of the specification, reference will be made to the idealized Airy disc situation. It is to be understood, however, that any comments made with regard to such Airy disc are equally pertinent to the point spread function.

[0101] FIG. 9 is a schematic illustration of a cell 1100 that is comprised of resolvable subcellular units 1102 and non-resolvable subcellular features 1104.

[0102] The diameter of the Airy disc, " d_{airy} ," divided by M (the optical magnification of the imaging system), yields a volume reference factor. Each of dimensions 1106 and 1108 is substantially larger than this volume reference factor of at least 2 and, preferably, at least 3.

[0103] The diameter of the subcellular units 1102 generally is at least twice as big as the volume reference factor. In one embodiment, the refractive index of the units 1102 differs from the refractive index of the units 1104, and the refractive index of the entire cell also preferably differs from the refractive indices units 1102 and 1104.

[0104] FIG. 10 is a schematic illustration of the interaction of an input electrical field with the phase volume as one example of a stimulus. The input electric field 1200 interacts over a period of time (see delta t) with an object 1202. The "delta t" must be large enough for the imaging system to acquire the optical phase of the scattered and/or diffracted light from a detector for each of the functions $E_n(x, y, t_n)$. The other requirements for the preferred system are discussed in FIG. 10 and include: " $\Delta E_n(\Delta x_j, \Delta y_j, t_n)$ " must be less than $d_{\text{airy}/M}$, " $\Delta E_n(\Delta x_j, \Delta y_j, t_n)$ " for all I and j within an object region, " $d_{\text{airy}/m}$ " must have different coherent volumes. These requirements define how it is preferred to spatially and temporally modulate the input electric field E_n

[0105] FIG. 11 is a schematic illustration a test assembly that allows one of ordinary skill in the art to determine whether he has practiced applicant's process appropriately.

Referring to FIG. 11, applicant's process produces an image that meets the criteria specified in such Figure.

[0106] FIG. 12 is a schematic of a process 3000 that utilizes a beam splitter 3002 working in reverse as a beam combiner. A coherent beam of light 3004 (a reference bundle of light) is comprised of coherent volumes 3004/1, 3004/2, 3004/3, etc. The light beam 3004 is preferably traveling in the direction of arrow 3006.

[0107] Simultaneously, coherent beam of light 3008 travels in the direction of arrow 3010 through the sample 3012. The coherent volumes 3008/1 interact with coherent volumes 3004/1, the coherent volumes 3008/2 interact with the volumes 3004/2, and the coherent volumes 3008/3 interact with the coherent volumes 3004/3. Through the use of a half mirror beam combiner 3002, which combines the coherent volumes. These interactions are interferometric, and they furnish information about the phase of the light that has interacted with the sample.

[0108] FIG. 13 illustrates a "shearing-interferometric" process 3100 that is similar to the process depicted in FIG. 12 but in which the reference bundle of light 3004 is passed in the direction of arrow 3011 (see FIG. 13) rather than in the direction of arrow 3006 (see FIG. 12). As will be apparent, either or both of the processes of FIGS. 12 and/or 13 may be used with any the devices depicted in FIGS. 1-7 by the inclusion of a reference coherent beam.

[0109] FIG. 14 is a schematic of a process 3800 for scanning a three-dimensional sample not shown in three axes using multiple coherent threads 3802 and 3804.

[0110] FIG. 15 is a schematic illustration of a process 4000 for scanning a three-dimensional sample 4002 in three axes, axis 4004, axis 4006, and axis 4008. Different measurements are made at different points of time in different axes.

[0111] In the embodiment depicted, the coherent thread 4010 is caused to move in the x, y, and z axes within a reference zone 4012; the interferometric information thus produced exists in perturbed interaction zone 4014. As will be apparent, the coherent thread 4010 is part of a larger coherent volume 4016 that, in the embodiment depicted, has an irregular three-dimensional shape. As will also be apparent, more than one such coherent thread may be used.

[0112] In one embodiment, the means for delivering the light bundles 3004 (the reference bundle) is an optical fiber with a distal end whose core diameter is less than about 1 micron and, more preferably, less than about 0.5 microns. In this embodiment, such distal end may be used to scan cell volume either outside of cell walls or inside the cell walls. The distal end of such fiber preferably is comprised of means to penetrate the cell membrane. The optical fiber preferably is made from biocompatible glass.

[0113] FIG. 16 depicts a process similar to that depicted in FIG. 15 with the exception that the reference zone 4012 is outside of the sample 4002, the reference zone 4013 differs from the reference zone 4012, and the coherent thread 4011 differs from the coherent thread 4010. The resultant observation zone 4015 differs from observation zone 4014.

[0114] As can be seen, embodiments of the present invention permit biological functions to be observed in situ without being significantly disturbed by the observation.

This will lead to discovery of new biological functions and effect, determinations of the efficacy of drugs and the like, determine the course of disease and thereby ways to prevent, treat and/or cure disease. This enabling technology can lead to new products that result from and are logical extensions of the observations made possible from inventive aspects of the present invention. These therapeutic methods and compounds will be developed through observations enabled by embodiments of the present invention.

[0115] The present invention has been described by way of exemplary embodiments to which it is not limited. The present invention includes variations and modifications which will occur to the skilled artisan.

What is claimed is:

1. A method of imaging a sample, the method comprising:

- (a) temporally dividing a long coherent light wave into a plurality of coherent wavelets;
- (b) spatially modulating the phase of each coherent wavelet a known different amount, thereby producing a plurality of modulated wavelets;
- (c) interacting each of said plurality of modulated wavelet, with the sample, thereby producing a plurality of perturbed wavelets;
- (d) creating a spatial phase map of each perturbed wavelet;
- (e) constructing a sample image from each perturbed wavelet spatial phase map; and
- (f) statistically averaging all of the sample images to produce a final averaged image of the sample.

2. The method as set forth in claim 1 wherein the plurality of coherent wavelets is created from within one coherence length or less of the coherent wave.

3. The method as set forth in claim 2 wherein the coherent wave is electromagnetic radiation from a laser.

4. The method as set forth in claim 3 wherein the coherent wave is temporally divided into a plurality of coherent wavelets by feeding the coherent wave into a fiber-optic delay line and bleeding off each coherent wavelet with an electronically controlled coupling component.

5. The method as set forth in claim 4 wherein the fiber-optic delay line further comprises an optical pump to compensate for optical losses.

6. The method as set forth in claim 3 wherein the laser operates in a single longitudinal mode.

7. The method as set forth in claim 3 wherein the laser operates in a single transverse mode.

8. The method as set forth in claim 2 wherein the coherent wave is electromagnetic radiation with a wavelength in the range of about 30 to 1000 microns.

9. The method as set forth in claim 2 wherein the spatial modulating of each coherent wavelet is accomplished with a rotatable planar reflector, each known different amount of spatial modulation of each coherent wavelet being produced by rotating the planar reflector a different angular amount.

10. The method as set forth in claim 2 wherein the spatial modulating of each coherent wavelet is accomplished with a liquid crystal device.

11. The method as set forth in claim 2 wherein the spatial modulating of each coherent wavelet is accomplished with an acousto-optic device.

12. The method as set forth in claim 2 wherein the spatial modulating of each coherent wavelet is accomplished with a micro-electro-mechanical device.

13. The method as set forth in claim 2 wherein each modulated wavelet is directed to the sample by an optical lens.

14. The method as set forth in claim 2 wherein each modulated wavelet is directed to the sample by a waveguide.

15. The method as set forth in claim 14 wherein each modulated wavelet is coupled into the waveguide by a grating coupler.

16. The method as set forth in claim 15 wherein the grating coupler further comprises a plurality of diffraction gratings.

17. The method as set forth in claim 16 wherein each modulated wavelet is transmitted through the sample.

18. The method as set forth in claim 16 wherein each modulated wavelet is reflected from the sample.

19. The method as set forth in claim 2 wherein each sample image is constructed from each perturbed wavelet spatial phase map by a computational device programmed with an image construction program, the computational device is connected to one or more detector systems which create the perturbed wavelet spatial phase map.

20. The method as set forth in claim 19 wherein each of the one or more detector systems comprise a digital camera connected to a spatial phase measuring system.

21. The method as set forth in claim 2 further comprising the step of stimulating the sample with an external stimulus before the interacting step (c).

22. The method as set forth in claim 21 wherein the external stimulus is chosen from the group consisting of electromagnetic radiation, sound waves, electric fields, magnetic fields, a chemical stimulant, ion beams, electron beams, and combinations thereof.

23. The method as set forth in claim 2 further comprising the step of stimulating the sample with an external stimulus simultaneous with the interacting step (c).

24. The method as set forth in claim 23 wherein the external stimulus is chosen from the group consisting of electromagnetic radiation, sound waves, electric fields, magnetic fields, a chemical stimulant, ion beams, electron beams, and combinations thereof.

25. A system for forming an image of a sample comprising:

- a source that emits a coherent wave of radiation;
- a temporal modulation system positioned to collect the coherent wave, the temporal modulation system temporally divides the coherent wave into a plurality of coherent wavelets;
- a spatial modulation system positioned to collect each coherent wavelet, the spatial modulation system spatially modulates the phase of each coherent wavelet a known different amount thereby producing a plurality of modulated wavelets;
- a radiation transmission system positioned to direct each modulated wavelet to the sample thereby creating a plurality of perturbed wavelets as a result of each modulated wavelet interacting with the sample;
- a detection system positioned to detect each perturbed wavelet, the detection system creates a spatial phase map of each perturbed wavelet;

a computational system connected to the detection system, the computational system constructs a plurality of sample images based on the spatial phase map of each perturbed wavelet and statistically averages the plurality of sample images to produce a final averaged image of the sample.

26. The system set forth in claim 25 wherein the temporal modulation system temporally divides the coherent wave into a plurality of coherent wavelets within one coherence length or less of the coherent wave of radiation.

27. The system set forth in claim 26 wherein the source comprises a laser.

28. The system set forth in claim 27 wherein the temporal modulation system comprises a fiber-optic delay line connected to an electronically controlled bleed-off coupling component.

29. The system set forth in claim 28 wherein the fiber-optic line further comprises an optical pump to compensate for optical losses.

30. The system set forth in claim 27 wherein the laser operates in a single longitudinal mode.

31. The system set forth in claim 27 wherein the laser operates in a single transverse mode.

32. The system set forth in claim 26 wherein the coherent wave of radiation has a wavelength in the range of about 30 to 1000 microns.

33. The system set forth in claim 26 wherein the spatial modulation system comprises a planar rotatable reflector, each known different amount of spatial modulation is produced by different angles of rotation of the reflector.

34. The system set forth in claim 26 wherein the spatial modulation system comprises a liquid crystal device.

35. The system set forth in claim 26 wherein the spatial modulation system comprises an acousto-optic device.

36. The system set forth in claim 26 wherein the radiation transmission system comprises an optical lens.

37. The system set forth in claim 26 wherein the radiation transmission system comprises a waveguide.

38. The system set forth in claim 37 wherein the radiation transmission system further comprises a grating coupler, the grating coupler couples the modulated wavelets into the waveguide.

39. The system set forth in claim 38 wherein the grating coupler further comprises a plurality of diffraction gratings.

40. The system set forth in claim 39 wherein each modulated wavelet is transmitted through the sample.

41. The system set forth in claim 39 wherein each modulated wavelet is reflected from the sample.

42. The system set forth in claim 26 wherein the detection system comprises one or more digital cameras connected to a spatial phase measuring system.

43. The system set forth in claim 26 further comprising a sample stimulation system, the sample stimulation system stimulates the sample with an external stimulus before each modulated wavelet interacts with the sample.

44. The system set forth in claim 43 wherein the external stimulus is chosen from the group consisting of electromagnetic radiation, sound waves, electric fields, magnetic fields, a chemical stimulant, ion beams, electron beams, and combinations thereof.

45. The system set forth in claim 26 further comprising a sample stimulation system, the sample stimulation system stimulates the sample with an external stimulus simultaneous with each modulated wavelet interacting with the sample.

46. The system as set forth in claim 45 wherein the external stimulus is chosen from the group consisting of electromagnetic radiation, sound waves, electric fields, mag-

netic fields, a chemical stimulant, ion beams, electron beams, and combinations thereof.

47. A therapeutic method developed through observations made with the system of claim 25.

48. A therapeutic compound developed through observations made with the system of claim 25.

* * * * *