



US 20070177827A1

(19) **United States**

(12) **Patent Application Publication**

Tilman

(10) **Pub. No.: US 2007/0177827 A1**

(43) **Pub. Date: Aug. 2, 2007**

(54) **SLIDER END STOP FOR A RECLOSABLE BAG AND METHODS**

Publication Classification

(75) Inventor: **Paul A. Tilman**, Sherwood, WI (US)

(51) **Int. Cl.**
B65D 33/16 (2006.01)
A44B 19/16 (2006.01)

Correspondence Address:
MERCHANT & GOULD PC
P.O. BOX 2903
MINNEAPOLIS, MN 55402-0903

(52) **U.S. Cl.** **383/64; 24/399; 24/400**

(73) Assignee: **Reynolds Consumer Products, Inc.**

(57) **ABSTRACT**

(21) Appl. No.: **11/654,235**

(22) Filed: **Jan. 16, 2007**

A zipper profile arrangement for use in opening and closing a package. The zipper profile arrangement including a reclosable zipper profile having first and second zipper ends. End stops are located that the first and second zipper ends of the reclosable zipper profile. The ends stops include a volume of glue disposed between first and second zipper profiles of the reclosable zipper profile. The end stops prevent a slider of the zipper profile arrangement from separating from the reclosable zipper profile.

Related U.S. Application Data

(60) Provisional application No. 60/763,742, filed on Jan. 30, 2006.

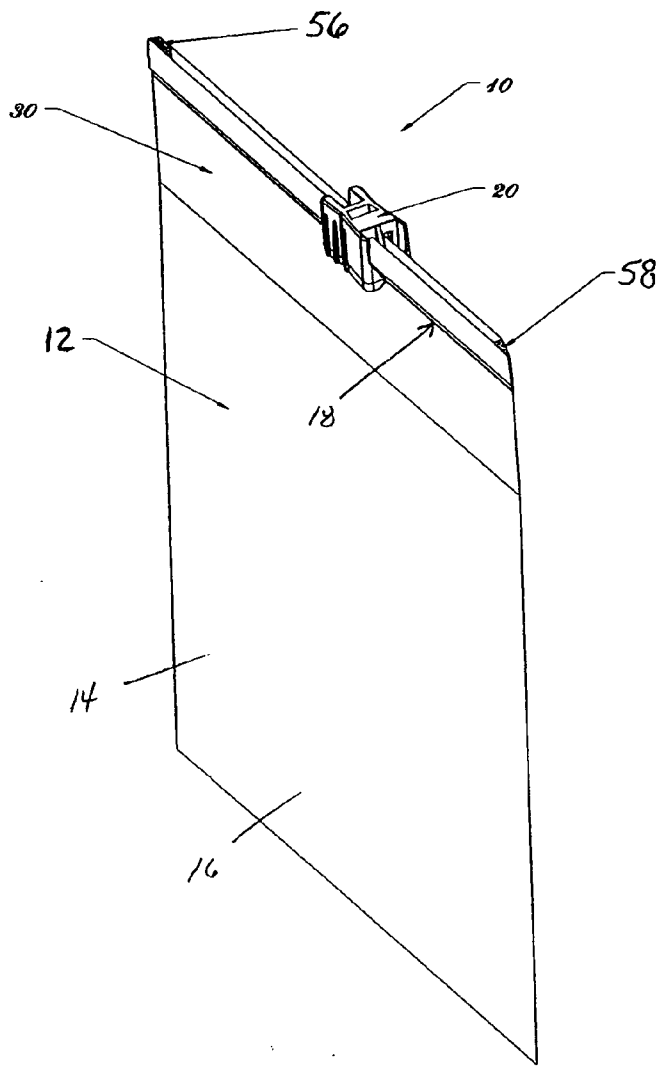

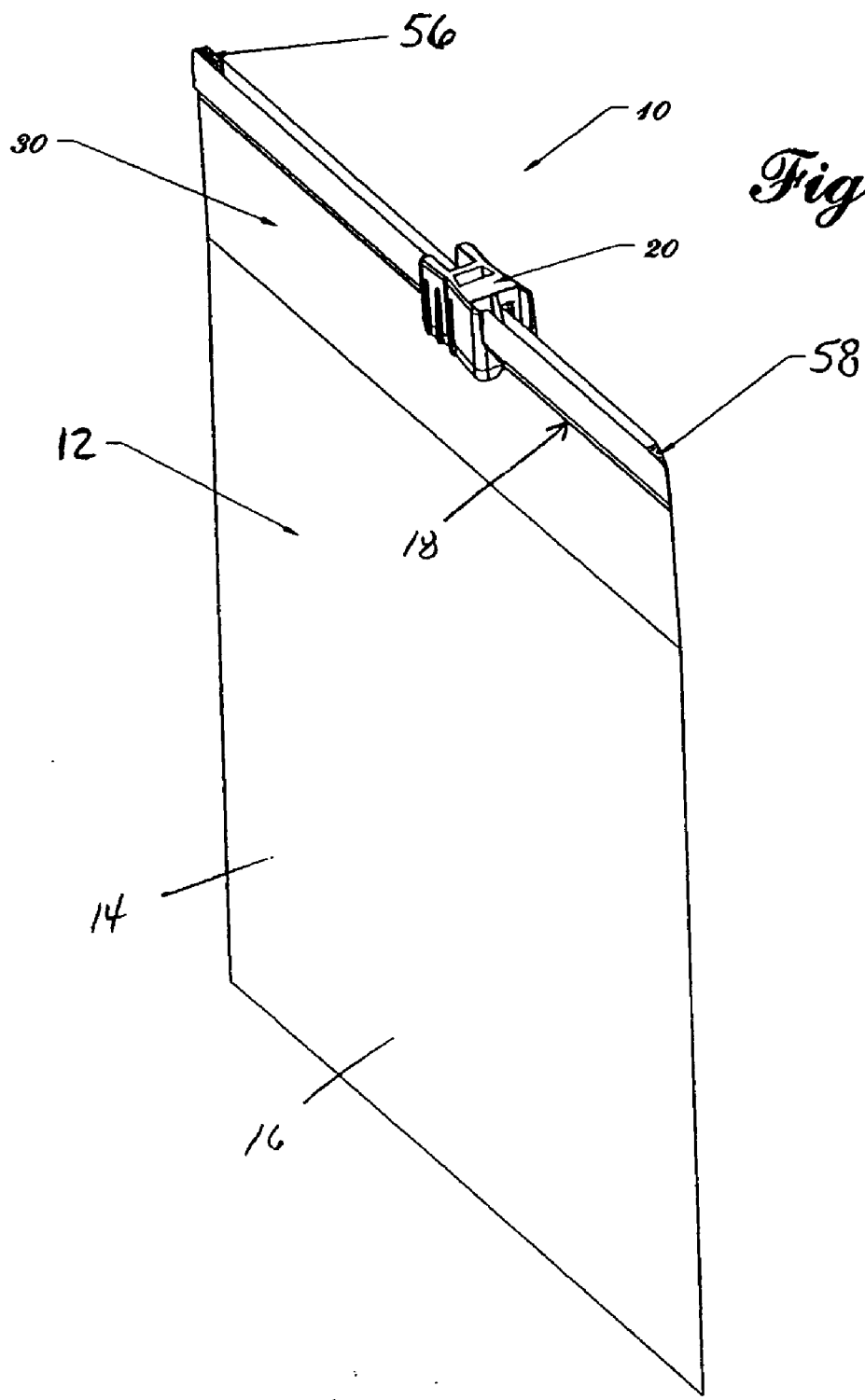

Figure 1

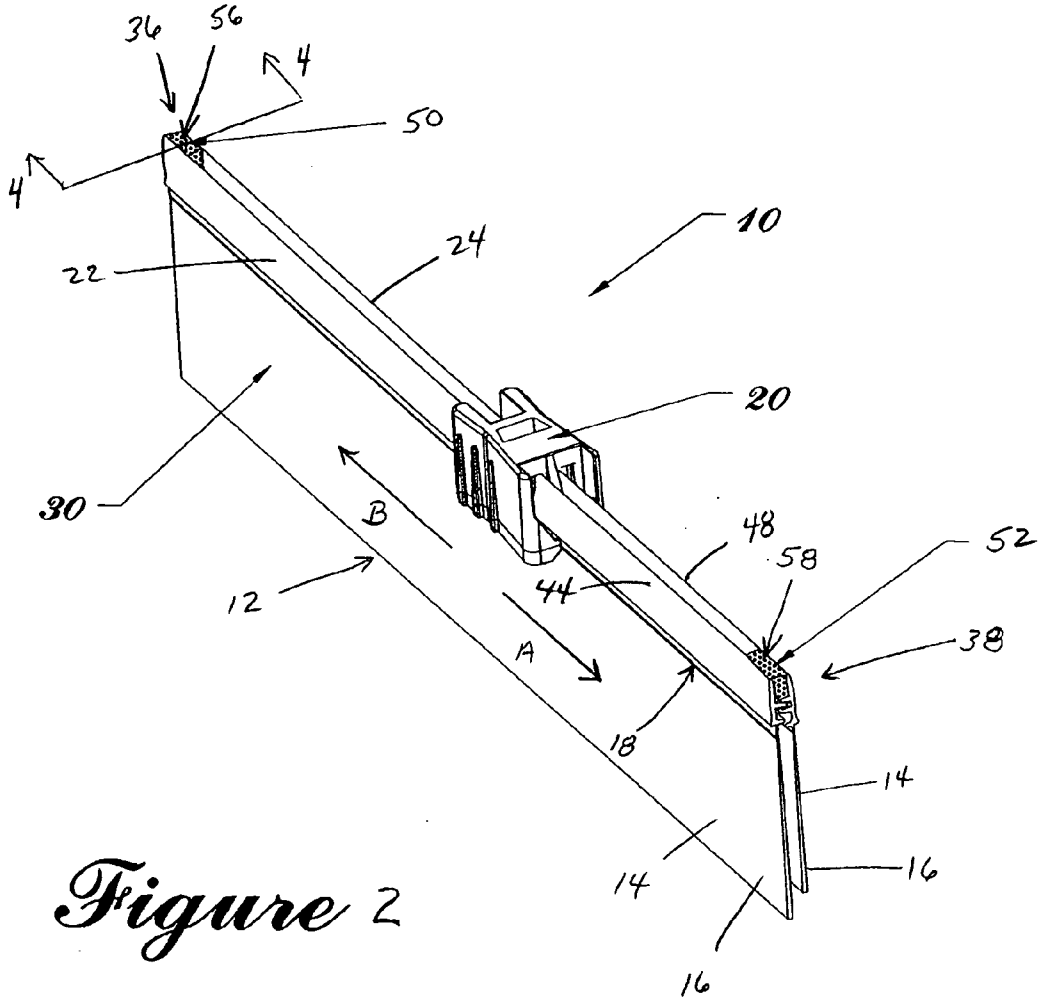

Figure 2

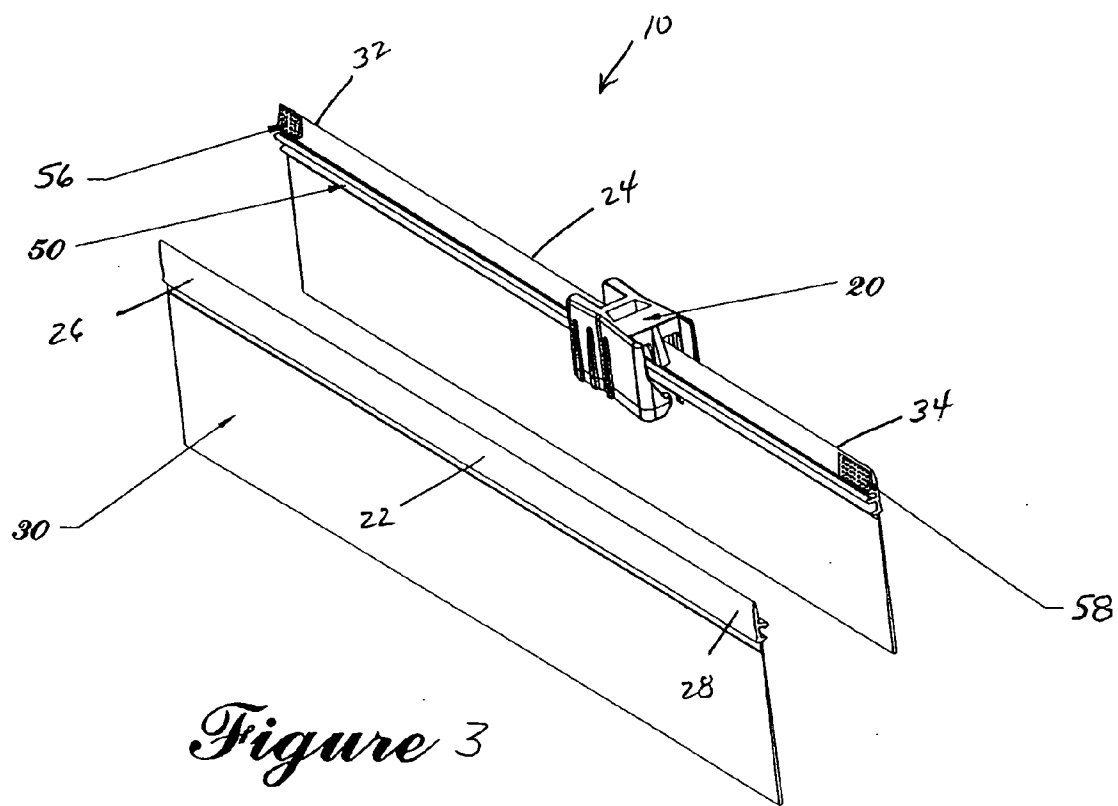

Figure 3

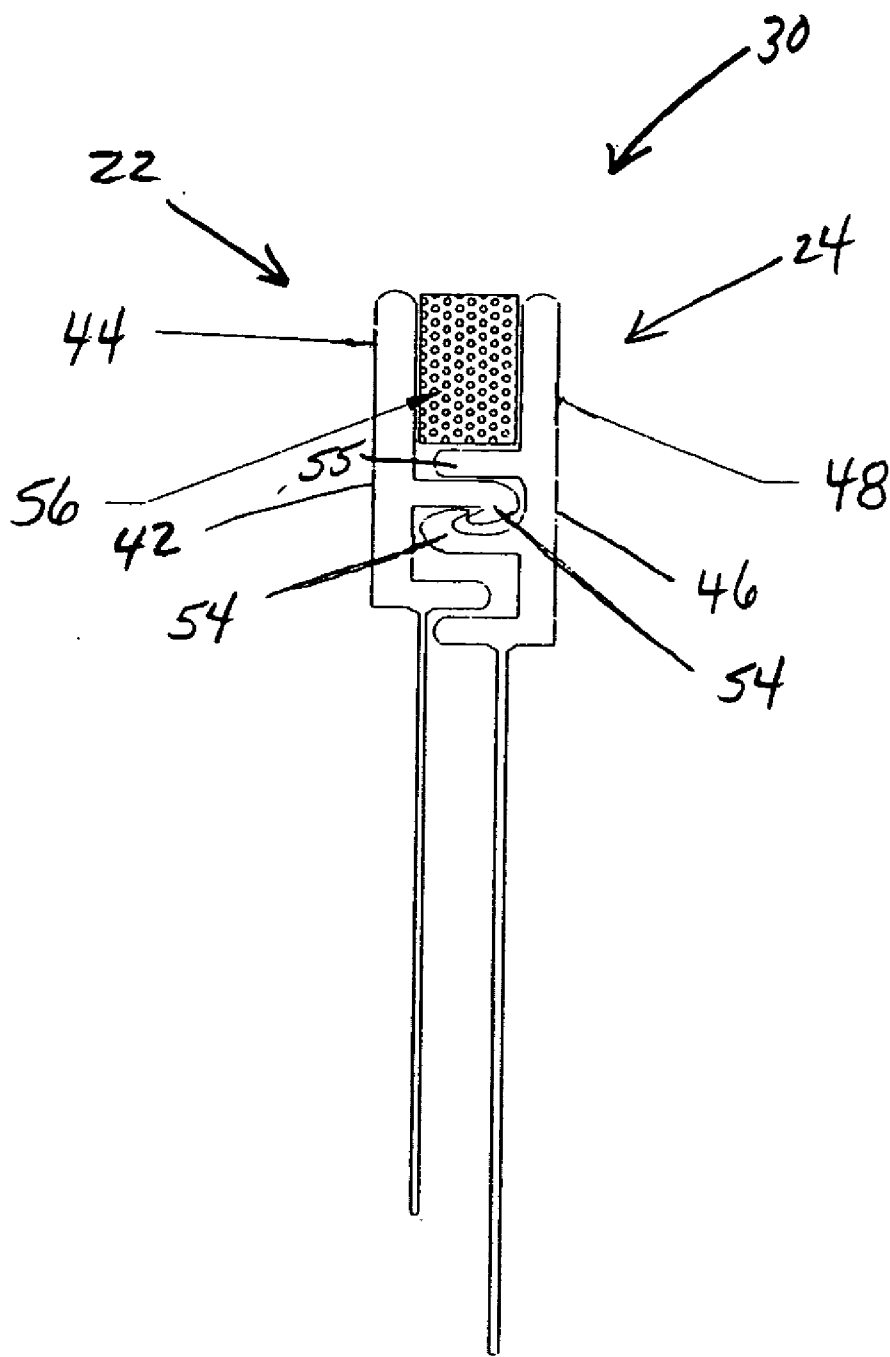

Figure 4

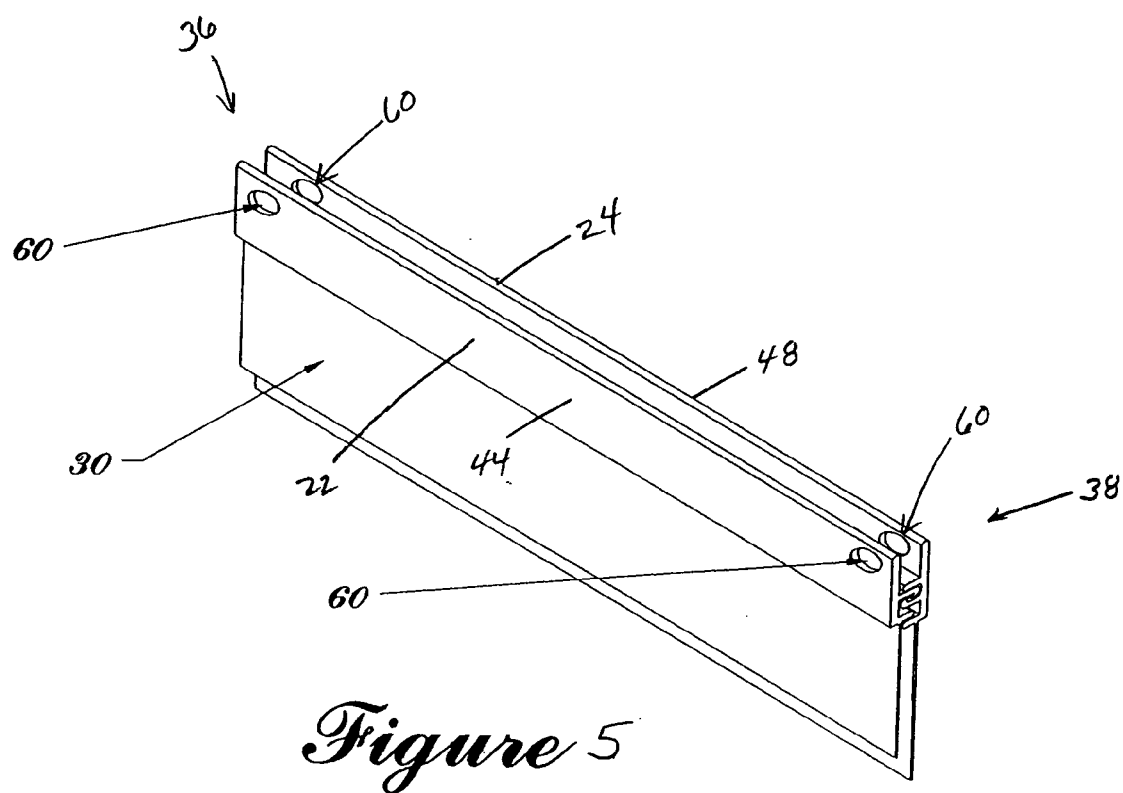

Figure 5

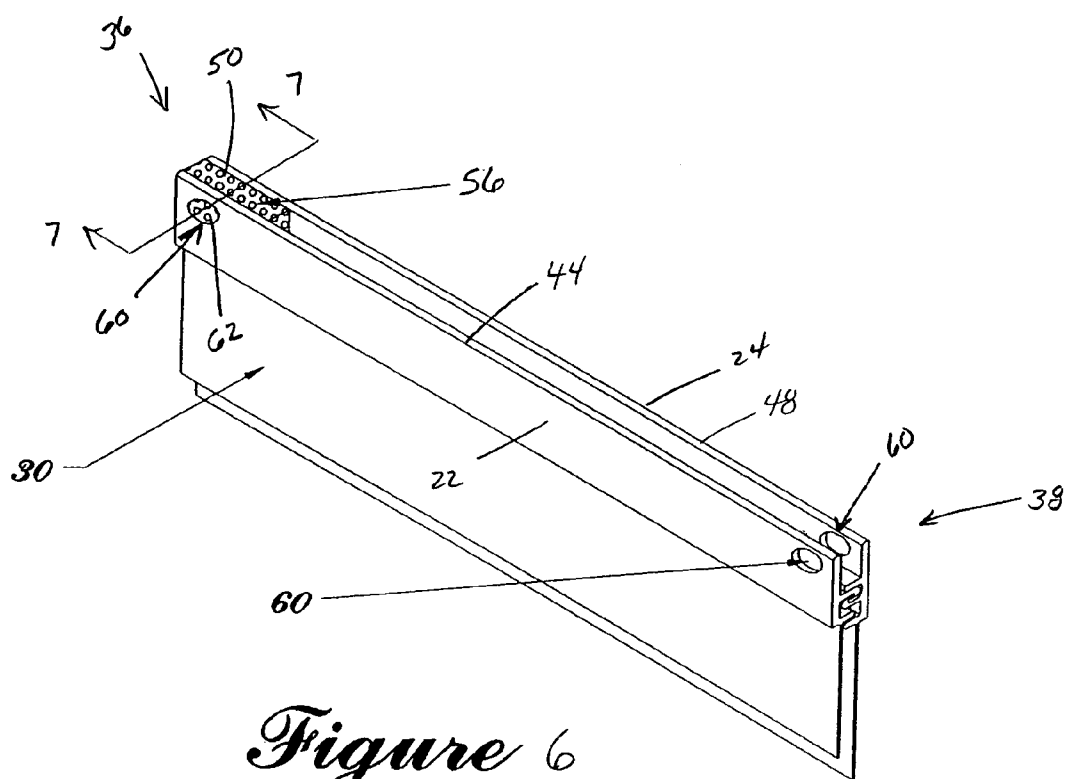

Figure 6

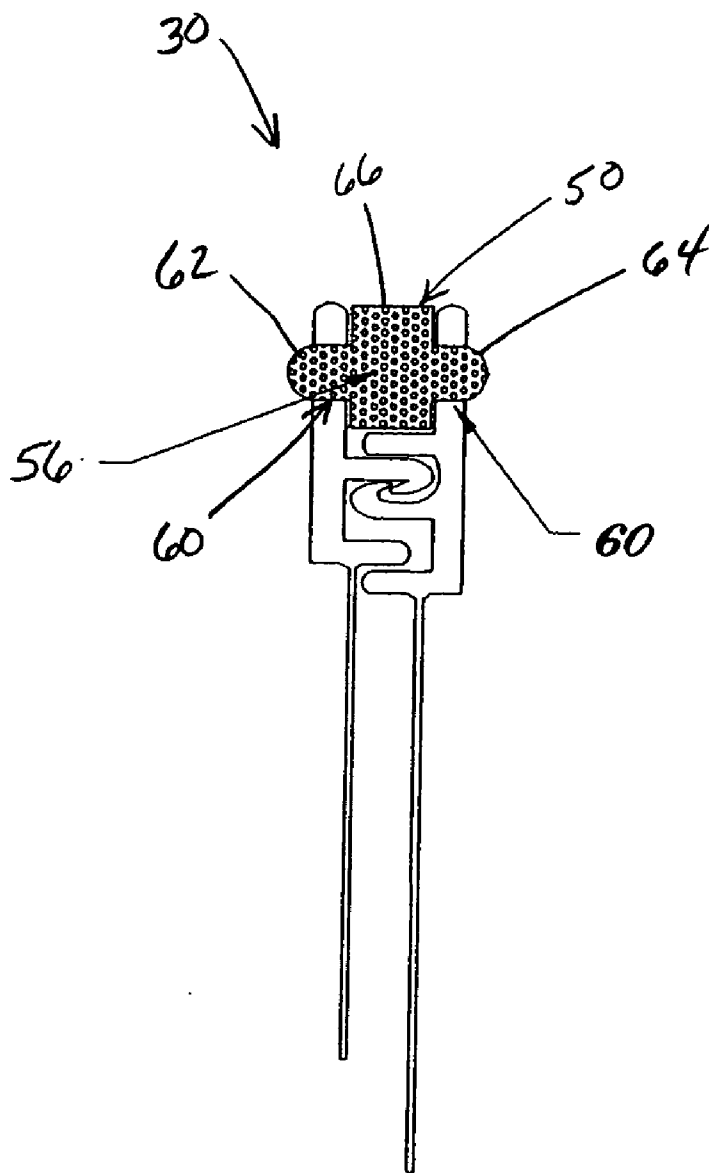
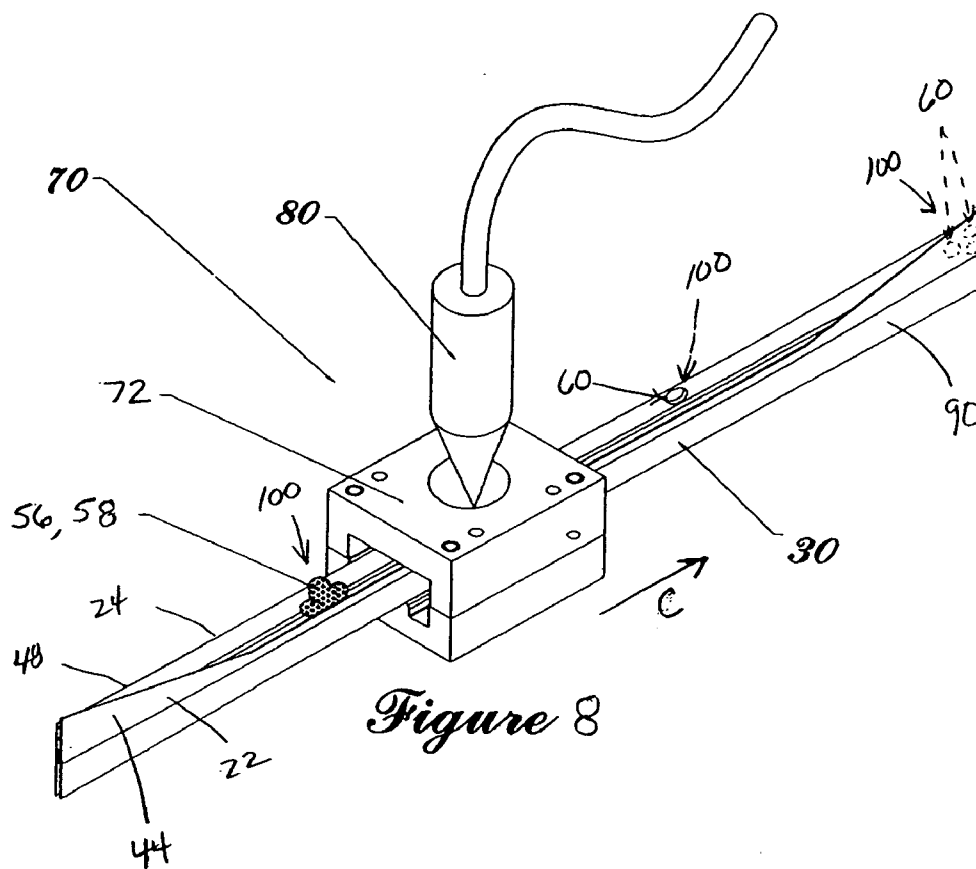

Figure 7



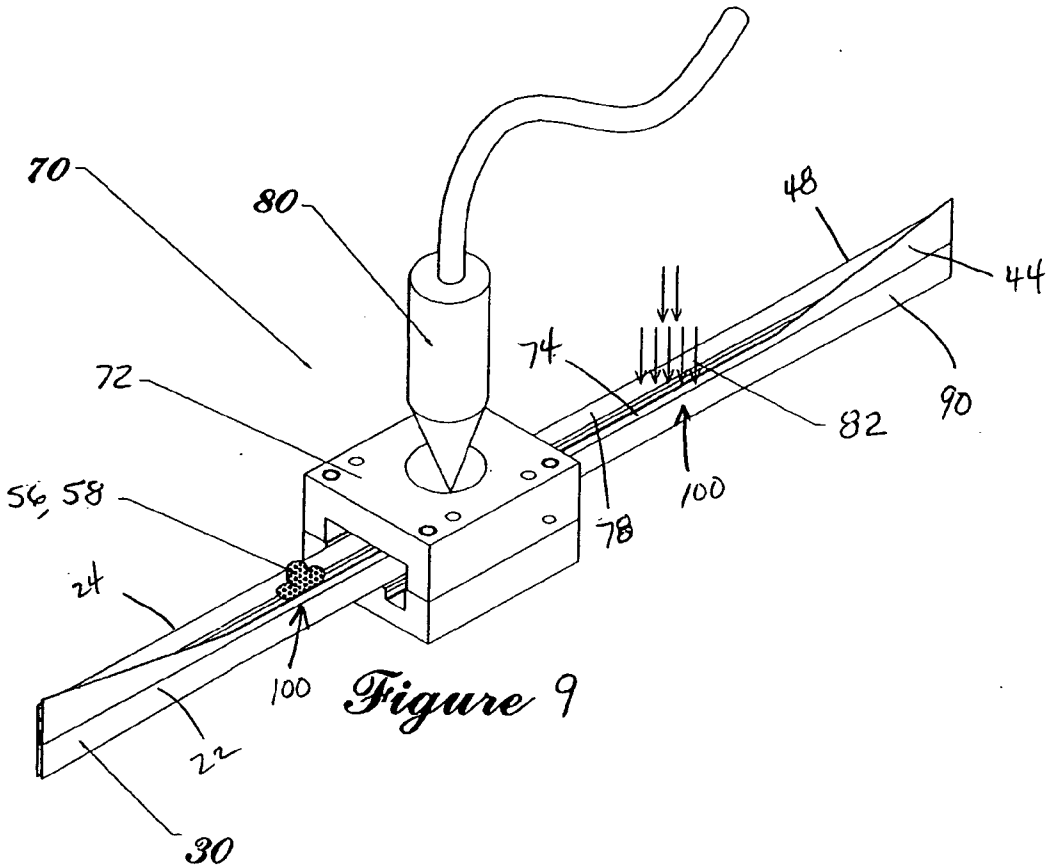

FIG. 10

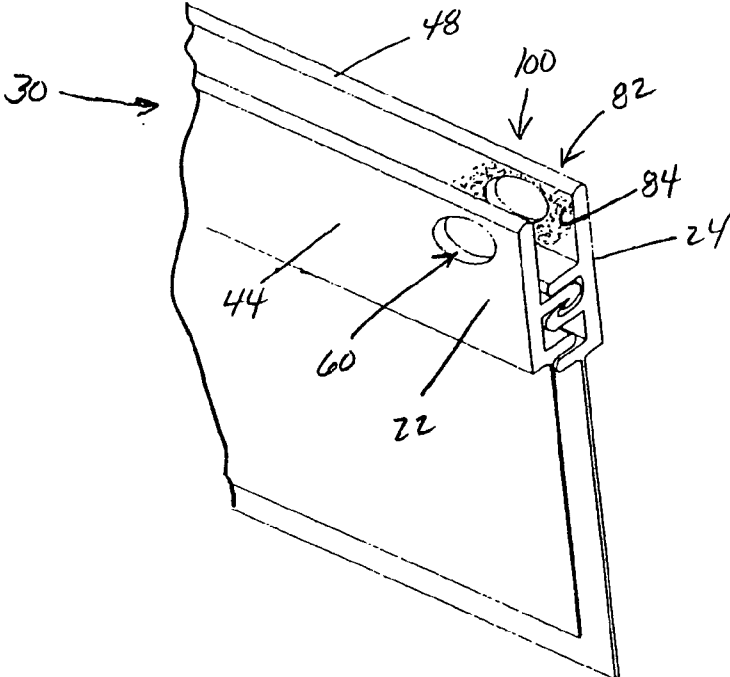
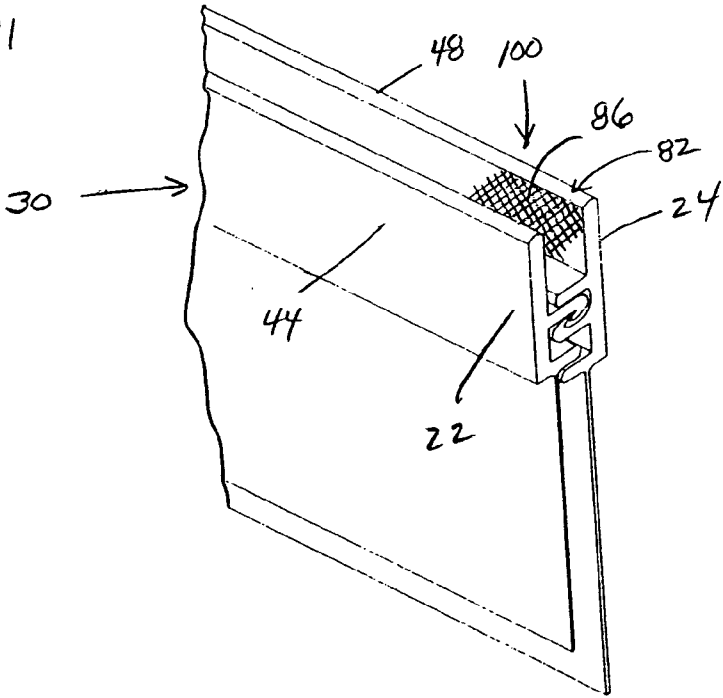

FIG. 11



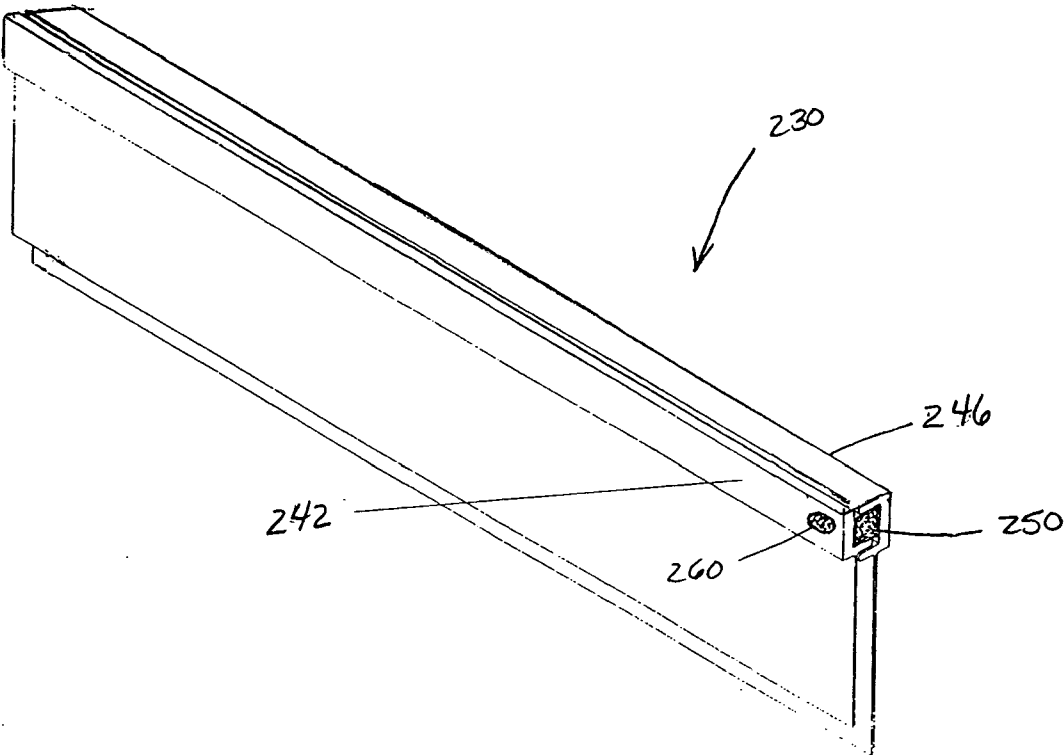
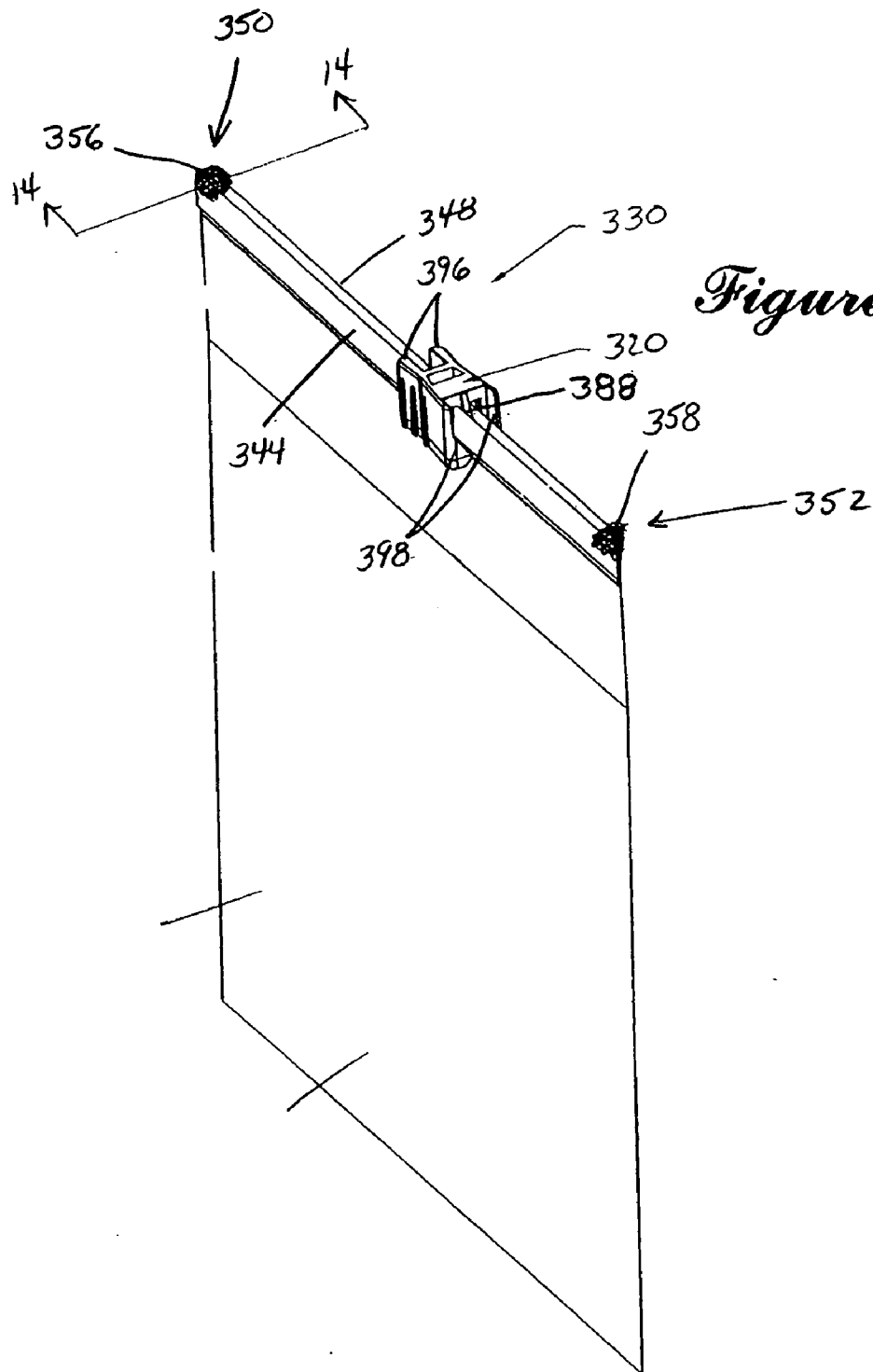

Figure 12



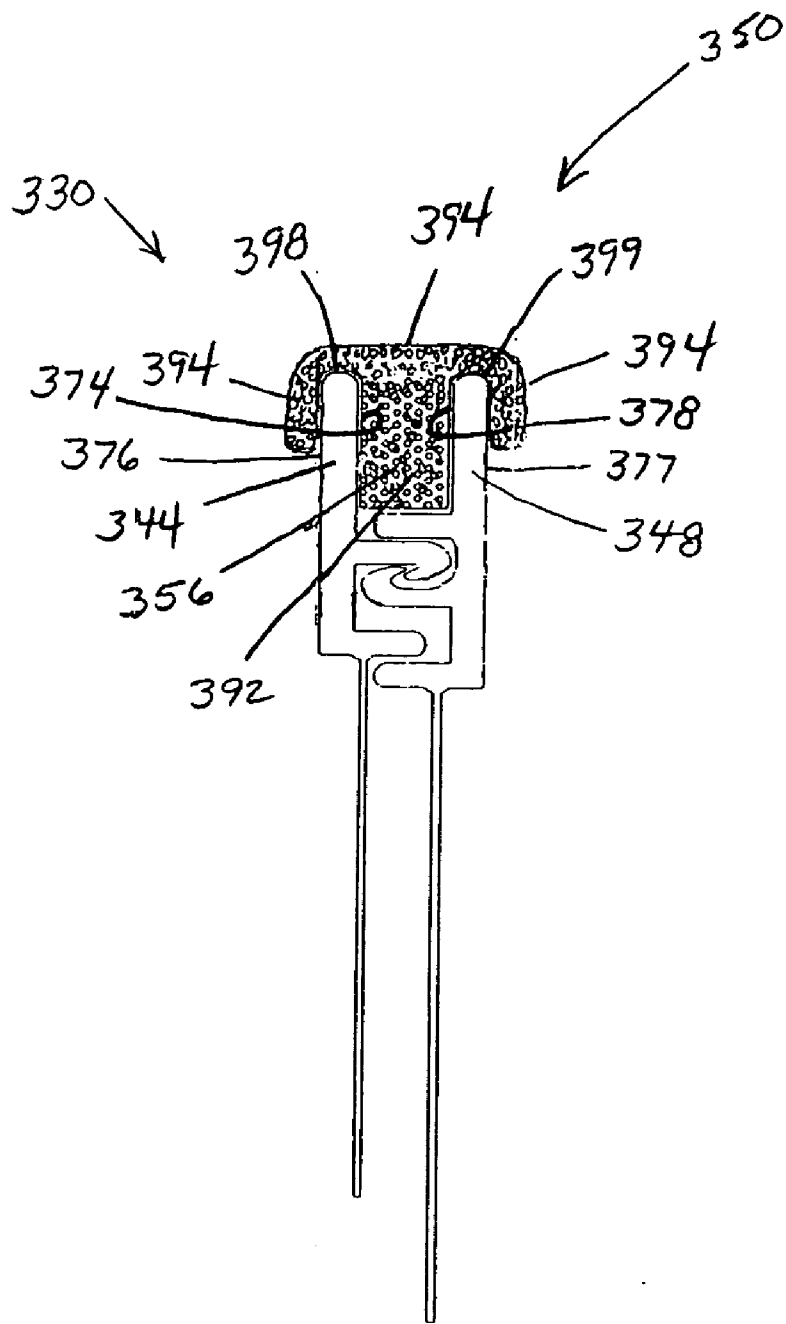

Figure 14

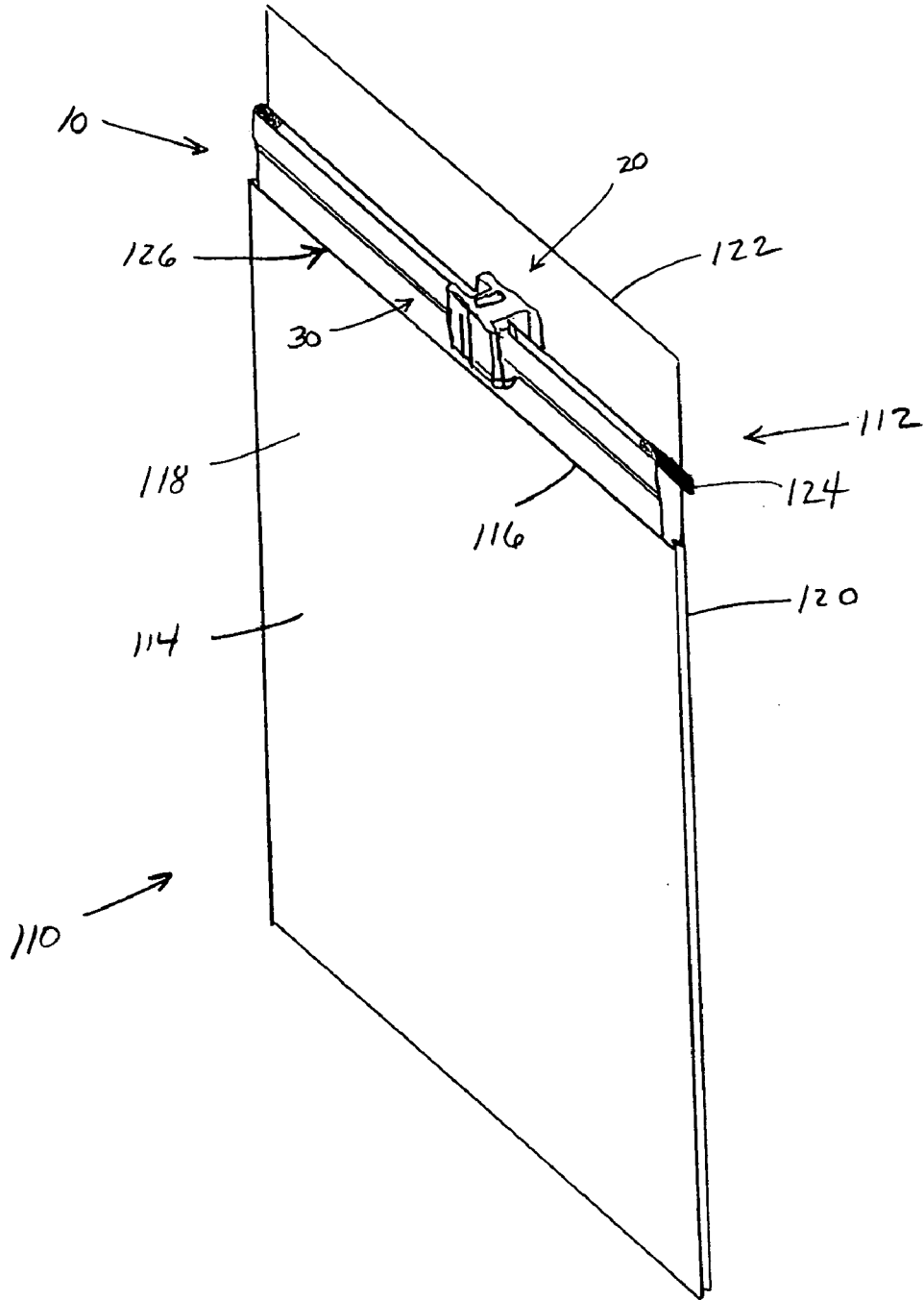
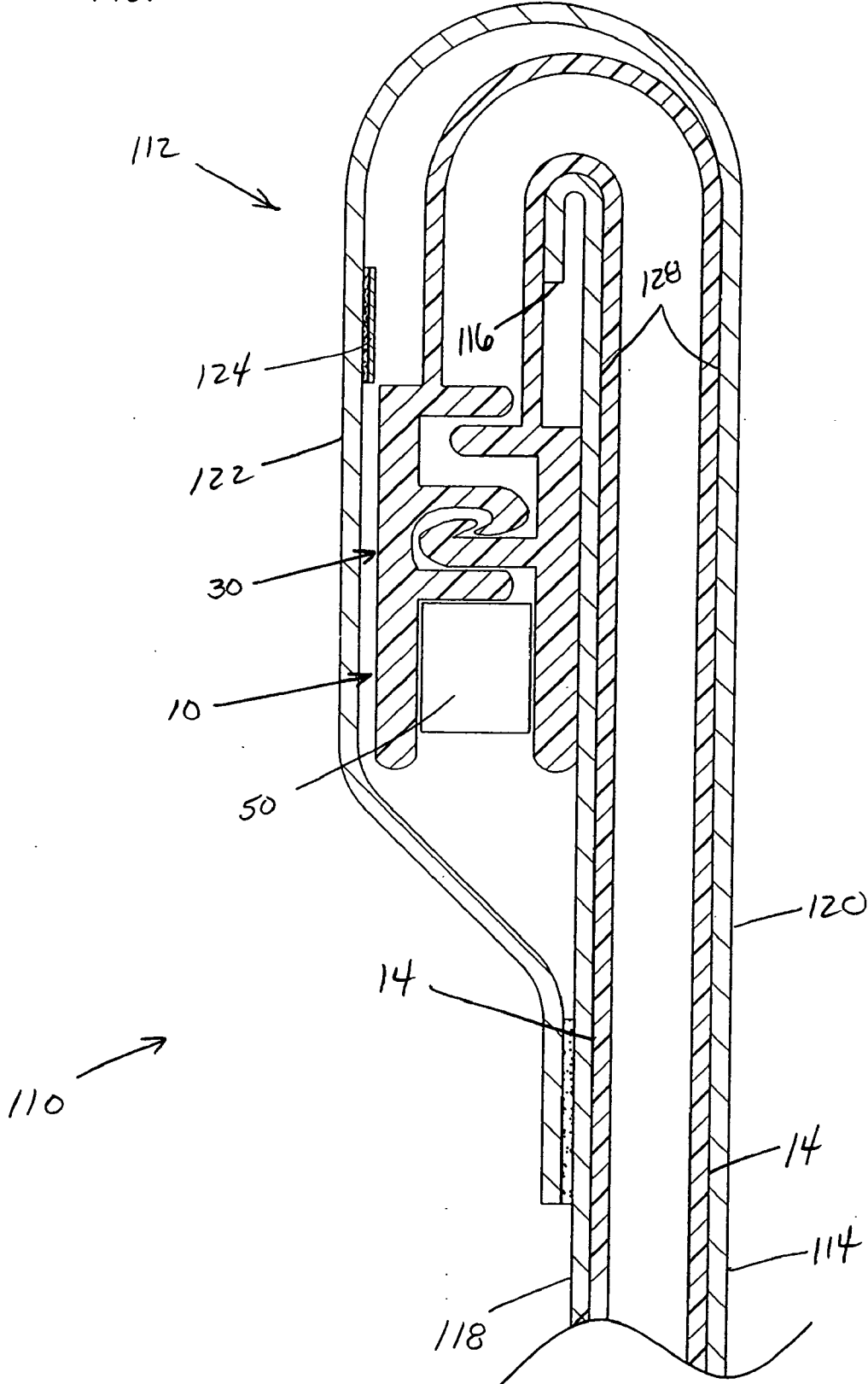

FIGURE 15

FIG. 16



SLIDER END STOP FOR A RECLOSABLE BAG AND METHODS

TECHNICAL FIELD

[0001] The present disclosure relates to a closure arrangement for a reclosable package. More particularly, the invention relates to closure arrangement having a slider end stop.

BACKGROUND

[0002] Reclosable packages and bags are used in many different applications. Reclosable bags, for example, often have zipper arrangements for sealing products within the bags. The zipper arrangements typically include a zipper profile having male and female profiles that interlock when pressed together along the length of the zipper. A slider can be used to press the male and female profiles together to close the bags. In such arrangements, the slider is also used to unlock the male and female profiles to open the bags.

[0003] Conventional zipper arrangements utilized a number of end stop configurations to prevent the slider from separating from or coming off the end of the zipper profile. Some end stop configurations are formed by heating a portion of the zipper profile, or by using ultrasonic technology to form the end stop. Other end stop configurations include applying glue to an outer surface of the zipper profile or attaching a strap to the zipper profile. Yet, with each of these end stop configurations, the slider still has a tendency to come off the end of the zipper profile.

[0004] Consequently, a need exists for an improved end stop that prevents a slider from coming off the end of a zipper profile.

SUMMARY

[0005] One aspect of the present disclosure relates to a zipper profile arrangement including a reclosable zipper profile, a slider for opening and closing the reclosable zipper profile, and end stops located at opposite ends of the reclosable zipper profile. The end stops include glue or adhesive disposed between either members or ears of the reclosable zipper profile. The end stops prevent the slider from separating from the reclosable zipper profile.

[0006] Another aspect of the present disclosure relates to a paper bag having a zipper profile arrangement including a plastic zipper profile and a plastic slider for opening and closing the zipper profile. The bag includes a flap portion that encloses the zipper profile arrangement.

[0007] A variety of examples of desirable product features or methods are set forth in part in the description that follows, and in part will be apparent from the description, or may be learned by practicing various aspects of the disclosure. The aspects of the disclosure may relate to individual features as well as combinations of features. It is to be understood that both the foregoing general description and the following detailed description are explanatory only, and are not restrictive of the claimed invention.

BRIEF DESCRIPTION OF THE DRAWINGS

[0008] FIG. 1 is a perspective view of a package having a reclosable zipper arrangement, in accordance with the principles of the present disclosure;

[0009] FIG. 2 is a perspective view of the reclosable zipper arrangement of FIG. 1, showing one embodiment of a zipper profile and a slider;

[0010] FIG. 3 is a partially exploded view of the reclosable zipper arrangement of FIG. 2;

[0011] FIG. 4 is a cross-sectional view of the zipper profile of FIG. 2, taken along line 4-4;

[0012] FIG. 5 is a perspective view of another embodiment of a zipper profile that can be used in the reclosable zipper arrangement of FIG. 1;

[0013] FIG. 6 is a perspective view of the zipper profile of FIG. 5, shown with an end stop, in accordance with the principles of the present disclosure;

[0014] FIG. 7 is a cross-sectional view of the zipper profile of FIG. 6, taken along line 7-7;

[0015] FIG. 8 is a perspective view of the zipper profile of FIG. 6, illustrating one method of manufacture;

[0016] FIG. 9 is a perspective view of the zipper profile of FIG. 2, illustrating another method of manufacture;

[0017] FIG. 10 is a partial perspective view of the zipper profile of FIG. 6, showing one type of a manufacture treatment;

[0018] FIG. 11 is a partial perspective view of the zipper profile of FIG. 2, showing another type of a manufacture treatment;

[0019] FIG. 12 is a perspective view of another embodiment of a zipper profile, shown with an end stop, in accordance with the principles of the present disclosure;

[0020] FIG. 13 is a perspective view of the package having a zipper profile as illustrated in FIGS. 1-4, showing another embodiment of a end stop, in accordance with the principles disclosed;

[0021] FIG. 14 is a cross-sectional view of the zipper profile and end stop of FIG. 13, taken along line 14-14;

[0022] FIG. 15 is a perspective view of a bag including a reclosable zipper arrangement, in accordance with the principles of the present disclosure; and

[0023] FIG. 16 is a cross-sectional view of the bag of FIG. 15, shown with the reclosable zipper arrangement enclosed by a flap portion of the bag.

DETAILED DESCRIPTION

[0024] Reference will now be made in detail to various features of the present disclosure that are illustrated in the accompanying drawings. Wherever possible, the same reference numbers will be used throughout the drawings to refer to the same or like parts.

[0025] FIGS. 1-9 illustrate embodiments of reclosable zipper arrangements 10 having features that are examples of how inventive aspects in accordance with the principles of the present disclosure may be practiced. Preferred features are adapted for preventing separation of the various components of the zipper arrangement 10 to provide a consumer with a reliable reclosable arrangement that accommodates extended and repeated use a bag, for example.

[0026] Referring now to FIG. 1, one embodiment of a zipper profile arrangement 10 is illustrated. The zipper profile arrangement 10 is provided on a package 12. The zipper profile arrangement 10 can be selectively opened to access an interior of the package 12, and selectively closed to seal the package. In the illustrated embodiment, the package 12 is made of a package film 14, such as a flexible package film, having a surrounding wall 16 that defines the interior. A mouth 18 provides access to the interior of the package. The zipper profile arrangement 10 is oriented along the mouth 18 of the package 12 to provide selective opening and closing of the mouth.

[0027] Referring now to FIG. 2, the zipper profile arrangement 10 includes a reclosable zipper profile 30. The reclosable zipper profile 30 includes a first zipper profile 22 and a second zipper profile 24 that opposes the first zipper profile. The zipper profile arrangement 10 also includes a slider 20. In the illustrated embodiment, the first zipper profile 22, the second zipper profile 24, and the slider 20 are made of plastic, preferably a thermoplastic.

[0028] The slider 20 is mounted on the first and second zipper profiles 22, 24, and is constructed to selectively mate and un-mate the first and second zipper profiles 22, 24 in response to moving or sliding the slider 20 along the zipper profile 30. For example, the slider 20 can move along the zipper profile in a first direction (represented by arrow A) to mate the zipper profiles and close the package 12. The slider 20 can also move along the zipper profile 30 in an opposite second direction (represented by arrow B) to un-mate the zipper profiles and open the package 12.

[0029] Referring now to FIG. 3, the first zipper profile 22 of the reclosable zipper profile 30 has a first end 26 and an opposite second end 28. The second zipper profile 24 also has a first end 32 and an opposite second end 34. The first end 26 of the first zipper profile 22 and the first end 32 second zipper profile 24 oppose one another to define a first zipper end 36 (FIG. 2) of the reclosable zipper profile 30. The second end 28 of the first zipper profile 22 and the second end 34 of the second zipper profile 24 oppose one another to define a second zipper end 38 (FIG. 2) of the reclosable zipper profile 30.

[0030] Referring now to FIG. 4, the first zipper profile 22 includes a first profile member 42 and a first ear 44 extending from the first profile member 42. The first profile member 42 and the first ear 44 extend along the length of the first zipper profile 22. The second zipper profile 24 includes a second profile member 46 and a second ear 48 extending from the second profile member 46. The second profile member 46 and the second ear 48 extend along the length of the second zipper profile 24.

[0031] Each of the first and second profile members 42, 46 of the first and second zipper profiles 22, 24 includes an interlocking element 54. The interlocking elements 54 engage one another (as shown) to seal the package 12 when the zipper profile 30 is closed. The slider 20 (FIG. 2) is configured and arranged to engage and interlock the elements 54. The slider 20 also disengages the elements 54 when the zipper profile 30 is opened. Many different embodiments of the zipper profiles 22, 24 are useable. In the particular ones shown, the interlocking elements 54 have J-shaped cross-sections. The second zipper profile 24 also includes a post 55 that helps the interlocking elements 54 maintain a mated or interlocked orientation.

[0032] Referring back to FIG. 2, the zipper profile arrangement 10 of the present disclosure also includes first and second end stops 50, 52. In the embodiment shown, the first end stop 50 is located at the first zipper end 36 of the reclosable zipper profile 30. In the embodiment shown, the second end stop 52 is located at the second zipper end 38 of the reclosable zipper profile 30. The end stops 50, 52 are constructed and arranged to limit motion of the slider 20 so that the slider does not separate from the zipper profile 30. While the end stops 50, 52 in this embodiment are shown at the ends 36, 38 of the zipper profile 30, it should be understood that in other embodiments, the end stops 50, 52

can be at any point along the zipper profile 30, depending on where it is desired to limit motion of the slider 20.

[0033] In the illustrated embodiment, the end stops 50, 52 are made from first and second volumes of glue or adhesive 56, 58. The volumes of adhesive 56, 58 are disposed at the each of the zipper ends 36, 38 between the first and second ears 44, 48 of the first and second opposing zipper profiles 22, 24. In an alternative embodiment, such as shown in FIG. 12, end stops 250 (only one shown) can be made from volumes of adhesive disposed between first and second profile members 242, 246, instead of between first and second ears. That is, the end stops can be provided on a reclosable zipper profile 230 without ears, in accordance with the principles disclosed.

[0034] Referring now to FIG. 5, apertures or holes 60 may be formed in each of the first and second ears 44, 48 of the first and second zipper profiles 22, 24. In one method of manufacture, the apertures 60 are punched into the ears 44, 48 by a punch press, for example. In the illustrated embodiment, the apertures 60 are located in each of the ears 44, 48 adjacent to each of the first and second ends 36, 38 of the reclosable zipper profile 30. Referring to FIG. 12, apertures 260 may similarly be formed in the profile members 242, 246.

[0035] In the reclosable zipper profile embodiments of FIG. 5 and 12, the end stops (e.g. 50) each include first and second adhesive portions 62, 64 (FIG. 7) located within the apertures 60. The first and second adhesive portions 62, 64 are connected by a primary portion 66 of the volume of adhesive (e.g. 56). The first and second adhesive portions 62, 64 located within the apertures 60, and the primary portion 66 of the volume of adhesive 56, connect the first ear 44 of the first zipper profile 22 to the second ear 48 of the second zipper profile 24 at the zipper ends 36, 38. The construction of this end stop embodiment functions somewhat like a rivet to provide enhanced structural integrity of the zipper profile arrangement 10 in certain applications where extra structural strength is required.

[0036] In an alternative embodiment, the first and second ears 44, 48 of the first and second zipper profiles 22, 24 (or the profile members 242, 246 of FIG. 12) can include a plurality of apertures or holes 60 (shown in dashed line in FIG. 8) to form end stops as previously described. The apertures of the illustrated embodiments can include circular holes, or other shaped holes that aid in enhancing the bond between the adhesive and the zipper profile 30, or that aid in enhancing the structural integrity of the zipper profile arrangement 10, for example.

[0037] Referring now to FIGS. 13 and 14, another embodiment of a first end stop 350 and a second end stop 352 is illustrated. Similar to the embodiment of FIG. 4, the end stops 350, 352 are made up of a volume of glue 356, 358 deposited between first and second ears 344, 348 of a reclosable zipper profile 330, as opposed to between first and second profile members 342, 346. Each of the volumes of glue or adhesive 356, 358 in this embodiment, however, is of an amount such that the volume overflows the first and second ears 344, 348 of the zipper profile 330.

[0038] By providing volumes of glue 356, 358 that overflow the ears 344, 348, the end stops (e.g. 350 in FIG. 14) have a first inner stop portion 392 and a second outer stop portion 394. The first inner stop portion 392 is the volume of adhesive disposed between the first and second ears 344, 348 of the zipper profile 330. The second outer stop portion

394 is the overflow of adhesive that flows or extends over, and is located above, a top edge **398, 399** (FIG. 14) of the respective first and second ears **344, 348**. In other words, the first inner stop portion **392** of the end stop is the portion disposed adjacent to opposing inner surfaces **374, 378** of the first and second ears **344, 348**; while the second outer stop portion **394** of the end stop is the portion disposed adjacent to outer surfaces **376, 378** of the first and second ears **344, 348**.

[0039] The illustrated end stops of FIGS. 13 and 14 prevent a slider **320** from sliding off the zipper profile **330** in two ways. In the first way, similar to the previous embodiments, the inner stop portion **392** contacts a plow **388** (FIG. 13) of the zipper **320** to prevent the zipper from sliding of the end of the zipper profile **330**. In another way, the outer stop portion **294** of the end stops **350, 352** contacts respective end portions or shoulders **396, 398** of the zipper **320** (FIG. 13) to prevent the zipper from sliding of the end of the zipper profile **330**.

[0040] Referring now to FIG. 8, one method of manufacturing the disclosed end stop embodiments of the zipper profile arrangement **10** is illustrated. During manufacture, a continuous length or web **90** of reclosable zipper profile is provided, which is subsequently cut to a number of desired lengths.

[0041] The method of manufacturing includes opening the zipper profile (e.g. **30**) with a spreader system **70** that moves along the web **90** in a direction (shown by arrow C). The illustrated spreader system **70** includes a profile block **72** that spreads apart the first and second ears **44, 48** of the first and second zipper profiles **22, 24**. As the spreader system **70** move along the web **90**, the volumes of adhesive **56, 58** are applied or deposited between the spread ears **44, 48** of the zipper profile **30** at predefined locations **100**. The adhesive can be applied by use of a nozzle **80**, for example. Once the volume of adhesive is applied, the ears **44, 48** of the zipper profile **30** are released and re-closed to contact the adhesive. Releasing and re-closing the ears **44, 48** squeezes the volume of adhesive so that the adhesive spreads within the space provided between the ears. In arrangements having apertures, the volume of adhesive is squeezed to flow into and/or through the apertures **60**. The adhesive is then permitted to cure and bond to the ears **44, 48** and to the apertures **60** formed in the ears. The cured volumes of adhesive define the end stops **50, 52**.

[0042] Referring now to FIG. 9, another method of manufacturing the end stops includes treating or applying a treatment **82** to opposing inner surfaces **74, 78** of the first and second ears **44, 48**. The treatment of the inner surfaces **74, 78** can be performed only at the predefined locations **100**, or along the entire length of the web **90**. As shown in FIG. 10, one treatment **82** that can be used involves roughening or pitting **84** the inner surfaces **74, 78** of the zipper profile **30**. Roughening or pitting **84** the inner surfaces increases the surface area to which the adhesive can bond; thereby enhancing the strength of the bond between the zipper profile **30** and the adhesive **56, 58**. In one method, the roughening or pitting **84** can be created by a Corona Treater machine, for example.

[0043] In yet another method, the opposing inner surfaces **74, 78** of the first and second ears **44, 48** are knurled or roughened **86**, as shown in FIG. 11. Knurling the inner

surfaces also increases the surface area to which the adhesive can bond; thereby enhancing the strength of the bond between the zipper profile **30** and the adhesive **56, 58**. As can be understood, enhancing the bond by pitting or knurling the inner surfaces **72, 74** can be applied to a zipper profile **30** with or with holes **60** formed in the ears **44, 48** (see FIGS. 10 and 11).

[0044] And, in still another embodiment, the volumes of adhesive **56, 58** applied between the ears can include adhesive with reinforcing fibers. The reinforcing fibers function to increase the structural integrity and cohesive strength of the adhesive. The reinforcing fibers can include, carbon fiber chains, for example.

[0045] As can be understood, each of the methods of manufacture previously described can be similarly applied to the manufacture of each of the embodiments disclosed herein.

[0046] Referring back to FIG. 2, in use, the slider **20** moves along the zipper profile in either of the first direction A to close the package **12**, or the second opposite direction B to open the package **12**. When either opening or closing the package, the slider **20** moves or slides along the zipper profile **30** until the slider **20** abuts or contacts one of the end stops **50, 52**. The end stops **50, 52** of the zipper profile arrangement **10** are constructed to reliably prevent separation the slider **20** from the reclosable zipper profile **30** to ensure repeated functional use of the package.

[0047] The disclosed zipper profile arrangement **10** can be used on a variety of packaging configurations, and used for sealing packages containing a variety of materials or goods. In one preferred embodiment, the disclosed zipper profile arrangement **10** is used on the packaging of bulk dry goods, such as pet food, for example. Referring to FIG. 15, one example bag **110** having a closure arrangement **112** that incorporates the disclosed zipper profile arrangement **10** is shown. The bag **110** includes an outer package material **114** that defines an opening or mouth **126**. In the illustrated embodiment, the outer package material **114** includes a paper material. The outer paper package material can include multiple plies of papers, or be of a single ply of paper material, depending upon the product or goods contained within the bag **110**.

[0048] The outer package material **114** and the zipper profile arrangement **10** are joined by gluing or adhering the package film **14** of the package **12** shown in FIG. 1 to an inside **128** (FIG. 16) of the outer package material **114**. In some embodiments, only a portion of the package film **14** is provided and adhered to the outer package material **114**; in other embodiments, the entire surrounding wall **16** (FIG. 1) of the package film **14** can be adhered to the outer package material **114**. In one embodiment, the package film **14** includes an inner polyethylene layer or film, for example. The inner polyethylene layer can be used in bags containing products for which it is desirable to retain moisture within the bag **110** or prevent moisture from entering the bag.

[0049] The package film **14** or portion of package film of the package **12** is secured to the inside **128** (FIG. 16) of the outer package material **114** along and adjacent to a top edge **116** of the outer package material **114**. In particular, the package film **14** is secured to the outer package material **114** such that the zipper profile arrangement **10** is located at the mouth **126** of the outer package material **114**.

[0050] The outer package material **114** includes a first side **118** and a second side **120**. As shown in FIG. 15, in the

illustrated embodiment, the zipper profile arrangement 10 extends above the top edge 116 of the outer package material 114 at the first side 118 of the outer package material. At the second opposite side 120 of the outer package material 114, a flap portion 122 extends above the zipper profile arrangement 10. The flap portion 122 is used to enclose the zipper profile arrangement 10 so that the zipper profile arrangement 10 is not inadvertently opened prior to use.

[0051] In particular, as shown in FIG. 16, the flap portion 122 and the reclosable zipper profile 30 of the zipper profile arrangement 10 fold over so that the flap portion 122 covers the folded, reclosable zipper profile 30. The extended flap portion 122 of the second side 120 of the outer package material 114 is secured to the first side 118 of the outer package material 114 in the folded orientation. In the illustrated embodiment, a release ribbon or strip 124 (see also FIG. 15) is provided adjacent to the reclosable zipper profile 30. The release ribbon 124 is glued or adhered to the inside 128 of the flap portion 122 of the bag 110 adjacent to the reclosable zipper profile 30. When the release ribbon 124 is pulled, the ribbon cuts through the flap portion 122 to provide access to the zipper 20 of the reclosable zipper profile 30.

[0052] To manufacture the bag 110 shown in FIGS. 15 and 16, a continuous length or web 90 (FIG. 8) of reclosable zipper profile is provided. Each of the slider 20 and the end stops (e.g. 52, FIG. 16) is attached and applied to the reclosable zipper profile 30, as previously described. The web 90 of reclosable zipper profile is then cut into discrete zipper profile elements (e.g. 30) having a length. The element is glued or adhered to the inside 128 of the outer package material 114. The zipper profile element (e.g. 30) and the flap portion 122 are folded in a U-shaped configuration; and the flap portion 122 is glued or adhered to the outer package material 114.

[0053] The above described paper bag 110 and closure arrangement 112 is easier and more convenient to use in comparison to conventional closure arrangements used on paper bags. Typical paper bag closure arrangements include string sewn closures and metal zippers. Conventional paper bags having string sewn closures are often difficult to initially open and do not permit reclosure. The disclosed arrangement 10 provides an easy to use and reclosable closure arrangement that eliminates the problems associated with string sewn closures.

[0054] The disclosed paper bag 110 is also more convenient to use and reliable than conventional paper bags having metal zippers. Metal zippers have teeth that interlock and engage one another to close or seal a bag. The teeth of the metal zipper of such bags often become clogged or fouled with the bulk product contained within the bag, rendering the metal zipper inoperable. The zipper profile arrangement 10 of the present disclosure provides a toothless zipper profile arrangement, that is, an arrangement that does not have interlocking or engaging teeth. The toothless zipper profiles of the disclosed arrangement 10 provide an easy to use, reliable reclosing closure arrangement that eliminates the problems associated with metal zipper closures.

[0055] The above specification provides a complete description of the invention. Since many embodiments of the invention can be made without departing from the spirit and scope of the invention, certain aspects of the invention reside in the claims hereinafter appended.

What is claimed is:

- 1. A zipper profile arrangement comprising:
 - (a) a first zipper profile including a first profile member and a first ear extending from the first profile member, the first ear including a roughened surface;
 - (b) a second zipper profile opposing the first zipper profile; the second zipper profile including a second profile member and a second ear extending from the second profile member, the second ear including a roughened surface opposing the first ear roughened surface;
 - (c) a slider member mounted on the first and second zipper profile; the slider member constructed and arranged to selectively mate and unmate the first zipper profile and second zipper profile responsive to motion of the slider member along the first and second zipper profiles; and
 - (d) a first end stop limiting motion of the slider member; the first end stop comprising adhesive between the first ear roughened surface and the second ear roughened surface.
- 2. A zipper profile arrangement according to claim 1 wherein:
 - (a) the first zipper profile has a first zipper profile first end and an opposite first zipper profile second end;
 - (b) the second zipper profile has a second zipper profile first end and a second zipper profile second end;
 - (i) the first zipper profile first end and the second zipper profile first end opposing each other to form a zipper first end;
 - (ii) the first zipper profile second end and the second zipper profile second end opposing each other to form a zipper second end; and
 - (c) the first end stop is on at least one of the zipper first end and zipper second end.
- 3. A zipper profile arrangement according to claim 2 further comprising:
 - (a) a second end stop limiting motion of the slider member; the second end stop comprising adhesive between the first ear and the second ear.
- 4. A zipper profile arrangement according to claim 3 wherein:
 - (a) the first end stop is on the zipper first end and the second end stop is on the zipper second end.
- 5. A zipper profile arrangement according to claim 1 wherein:
 - (a) the first ear includes at least one aperture;
 - (b) the second ear includes at least one aperture opposing the at least one aperture in the first ear; and
 - (c) the first end stop includes adhesive in the at least one aperture in the first ear and the at least one aperture in the second ear and connecting the first ear to the second ear.
- 6. A zipper profile arrangement according to claim 4 wherein:
 - (a) the first end stop includes at least one aperture in the first ear and second ear at the zipper first end with adhesive therein and connecting the first ear to the second ear at the zipper first end; and
 - (b) the second end stop includes at least one aperture in the first ear and second ear at the zipper second end with adhesive therein and connecting the first ear to the second ear at the zipper second end.

7. A zipper profile arrangement according to claim 1 wherein:

- (a) the first ear includes a plurality of apertures;
- (b) the second ear includes a plurality of apertures opposing the plurality of apertures in the first ear; and
- (c) the first end stop includes adhesive in the plurality of apertures in the first ear and the plurality of apertures in the second ear and connecting the first ear to the second ear.

8. A zipper profile arrangement according to claim 4 wherein:

- (a) the first end stop includes a plurality of apertures in the first ear and second ear at the zipper first end with adhesive therein and connecting the first ear to the second ear at the zipper first end; and
- (b) the second end stop includes a plurality of apertures in the first ear and second ear at the zipper second end with adhesive therein and connecting the first ear to the second ear at the zipper second end.

9. A zipper profile arrangement according to claim 1 wherein:

- (a) each of the first ear roughened surface and the second ear roughened surface is a knurled surface.

10. A zipper profile arrangement according to claim 1 wherein:

- (a) each of the first ear roughened surface and the second ear roughened surface is a pitted surface.

11. A zipper profile arrangement according to claim 4 wherein:

- (a) the first and second ears include roughened surfaces at each of the zipper first end and the zipper second end;
- (b) the first end stop includes adhesive between the roughened surfaces at the zipper first end; and
- (c) the second end stop includes adhesive between the roughened surfaces at the zipper second end.

12. A zipper profile arrangement according to claim 11 wherein:

- (a) the first end stop connects the first ear to the second ear at the zipper first end; and
- (b) the second end stop connects the first ear to the second ear at the zipper second end.

13. A package comprising:

- (a) a package film having a surrounding wall defining an interior and a mouth providing access to the interior;
- (b) a zipper oriented along the mouth to provide selective opening and closing of the mouth; the zipper including:
 - (i) a first zipper profile including a first profile member and a first ear extending from the first profile member;
 - (ii) a second zipper profile opposing the first zipper profile; the second zipper profile including a second profile member and a second ear extending from the second profile member;
 - (iii) a slider member mounted on the first and second zipper profile; the slider member constructed and arranged to selectively mate and unmate the first zipper profile and second zipper profile responsive to motion of the slider member along the first and second zipper profiles; and
 - (iv) a first end stop limiting motion of the slider member; the first end stop including a roughened surface in the first ear and the second ear at the zipper

first end with adhesive therebetween, the first end stop connecting the first ear to the second ear at the zipper first end.

14. A package according to claim 13 wherein:

- (a) the first zipper profile has a first zipper profile first end and an opposite first zipper profile second end;
- (b) the second zipper profile has a second zipper profile first end and a second zipper profile second end;
 - (i) the first zipper profile first end and the second zipper profile second end opposing each other to form a zipper first end;
 - (ii) the first zipper profile second end and the second zipper profile second end opposing each other to form a zipper second end;
- (c) the package further comprises a second end stop limiting motion of the slider member; the second end stop including a roughened surface in the first ear and the second ear at the zipper second end with adhesive therebetween, the second end stop connecting the first ear to the second ear at the zipper second end.

15. A package according to claim 14 wherein:

- (a) the first end stop includes at least one aperture in the first ear and second ear at the zipper first end with adhesive therein and connecting the first ear to the second ear at the zipper first end; and
- (b) the second end stop includes at least one aperture in the first ear and second ear at the zipper second end with adhesive therein and connecting the first ear to the second ear at the zipper second end.

16. A method of making a zipper profile arrangement; the method comprising:

- (a) providing a first zipper profile including a first profile member and a first ear extending from the first profile member;
- (b) providing a second zipper profile opposing the first zipper profile; the second zipper profile including a second profile member and a second ear extending from the second profile member;
- (c) mounting a slider member on the first and second zipper profile to selectively mate and unmate the first zipper profile and second zipper profile by moving the slider member along the first and second zipper profiles;
- (d) roughening a region in the first ear, and roughening a region in the second ear opposing the region of the first ear that is roughened; and
- (e) providing adhesive between the region of the roughened first ear and the region of the roughened second ear to create a first end stop limiting motion of the slider member.

17. A method according to claim 16 further comprising:

- (a) punching at least one hole in the first ear;
- (b) punching at least one hole in the second ear to opposing the at least one hole in the first ear; and
 - (i) the step of providing adhesive includes squeezing adhesive through the at least one hole in the first ear and the at least one hole in the second ear and to connect the first ear and second ear to each other.

18. A method according to claim 16 wherein:

- (a) the step of roughening includes treating inner surfaces of the first ear and the second ear with a corona treater to pit the inner surfaces and enhance the bond between the adhesive and the first and second ears.

19. A method according to claim 16 wherein:
- the step of roughening includes knurling the inner surfaces of the first ear and the second ear to enhance the bond between the adhesive and the first and second ears.
20. A method of using a zipper arrangement; the method comprising:
- moving a slider member along a zipper until the slider member abuts an end stop; the end stop including an adhesive that secures together opposing portions of the zipper, the opposing portions of the zipper including roughened surfaces.
21. A zipper profile arrangement comprising:
- a first zipper profile having a first interlocking element;
 - a second zipper profile opposing the first zipper profile; the second zipper profile including a second interlocking element;
 - a slider member mounted on the first and second zipper profile; the slider member constructed and arranged to selectively mate and unmate the first and second interlocking elements of the first and second zipper profiles in response to motion of the slider member along the first and second zipper profiles; and
 - a first end stop limiting motion of the slider member; the first end stop comprising a fiber reinforced adhesive disposed between the first zipper profile and the second zipper profile.
22. A zipper profile arrangement according to claim 21 wherein:
- each of the first and second zipper profiles defines an aperture, the aperture being located adjacent to the first end stop; and
 - portions of the first end stop extend through each of the apertures defined in each of the first and second zipper profiles.
23. A zipper profile arrangement according to claim 21 wherein:
- the first and second zipper profiles each include a profile member and an ear extending from the profile member, the first end stop being disposed between the ears of the first and second zipper profiles.
24. A zipper profile arrangement according to claim 21 wherein:
- the first and second zipper profiles each include a profile member, the interlocking elements of the first and second zipper profiles extending from the profile members, the first end stop being disposed between the profile members of the first and second zipper profiles.
25. A zipper profile arrangement comprising:
- a first zipper profile including a first profile member and a first ear extending from the first profile member;
 - a second zipper profile opposing the first zipper profile; the second zipper profile including a second profile member and a second ear extending from the second profile member;
 - a slider member mounted on the first and second zipper profile; the slider member constructed and arranged to selectively mate and unmate the first and second zipper profiles in response to motion of the slider member along the first and second zipper profiles; and
 - a first end stop limiting motion of the slider member; the first end stop including an inner stop portion and an outer stop portion, the inner stop portion being disposed only between the first and second ears of the first and second zipper profiles, the outer stop portion being disposed adjacent outer surfaces of the first and second ears of the first and second zipper profiles.
26. A zipper profile arrangement according to claim 25 wherein:
- the slider member includes a plow located between first and second shoulders, the first end stop arranged such that the plow contacts the inner stop portion and the shoulders contact the outer stop portion of the end stop to limit motion of the slider member.
27. A zipper profile arrangement according to claim 25 wherein:
- the inner stop portion is a volume of adhesive; and
 - the outer stop portion is an overflow of adhesive, the overflow of adhesive extending over a top edge of each of the first and second ears of the first and second zipper profiles.
28. A paper bag, comprising:
- a zipper profile arrangement including:
 - a first plastic zipper profile having a first interlocking element;
 - a second plastic zipper profile opposing the first zipper profile; the second zipper profile including a second interlocking element;
 - a plastic slider member mounted on the first and second zipper profile; the slider member constructed and arranged to selectively mate and unmate the first and second interlocking elements of the first and second zipper profiles in response to motion of the slider member along the first and second zipper profiles; and
 - an outer paper package material, the outer paper package material having an opening, the zipper profile arrangement being located at the opening of the outer paper package material, the outer paper package material further including:
 - a flap portion located adjacent to the opening, the flap portion being folded over the zipper profile arrangement to enclose a majority of the zipper profile arrangement.
29. A paper bag according to claim 28 further including:
- a first end stop limiting motion of the slider member; the first end stop comprising adhesive disposed between the first zipper profile and the second zipper profile.
30. A paper bag according to claim 28 wherein:
- the outer paper package material comprises multiple plies of paper.
31. A paper bag according to claim 30 further including:
- an inner polyethylene layer surrounded by the outer paper package material.
32. A paper bag, comprising:
- a toothless zipper profile arrangement including:
 - a first zipper profile including a first profile member and a first ear extending from the first profile member;
 - a second zipper profile opposing the first zipper profile; the second zipper profile including a second profile member and a second ear extending from the second profile member;

- (iii) a slider member mounted on the first and second zipper profile; the slider member constructed and arranged to selectively mate and unmate the first and second zipper profiles in response to motion of the slider member along the first and second zipper profiles; and
 - (iv) a first end stop limiting motion of the slider member; the first end stop comprising adhesive disposed between the first and second ears of the first zipper profile and the second zipper profile;
 - (b) an outer paper package material, the outer paper package material having an opening, the zipper profile arrangement being located at the opening of the outer paper package material.
- 33.** A paper bag according to claim **32** further including:
(a) a bag flap extending from the outer paper package material, the bag flap being located adjacent to the opening, the bag flap being folded over the zipper profile arrangement to enclose a majority of the zipper profile arrangement.
- 34.** A paper bag according to claim **32** wherein:
(a) the outer paper package material comprises multiple plies of paper.
- 35.** A paper bag according to claim **34** further including:
(a) an inner polyethylene layer surrounded by the outer paper package material.

* * * * *