

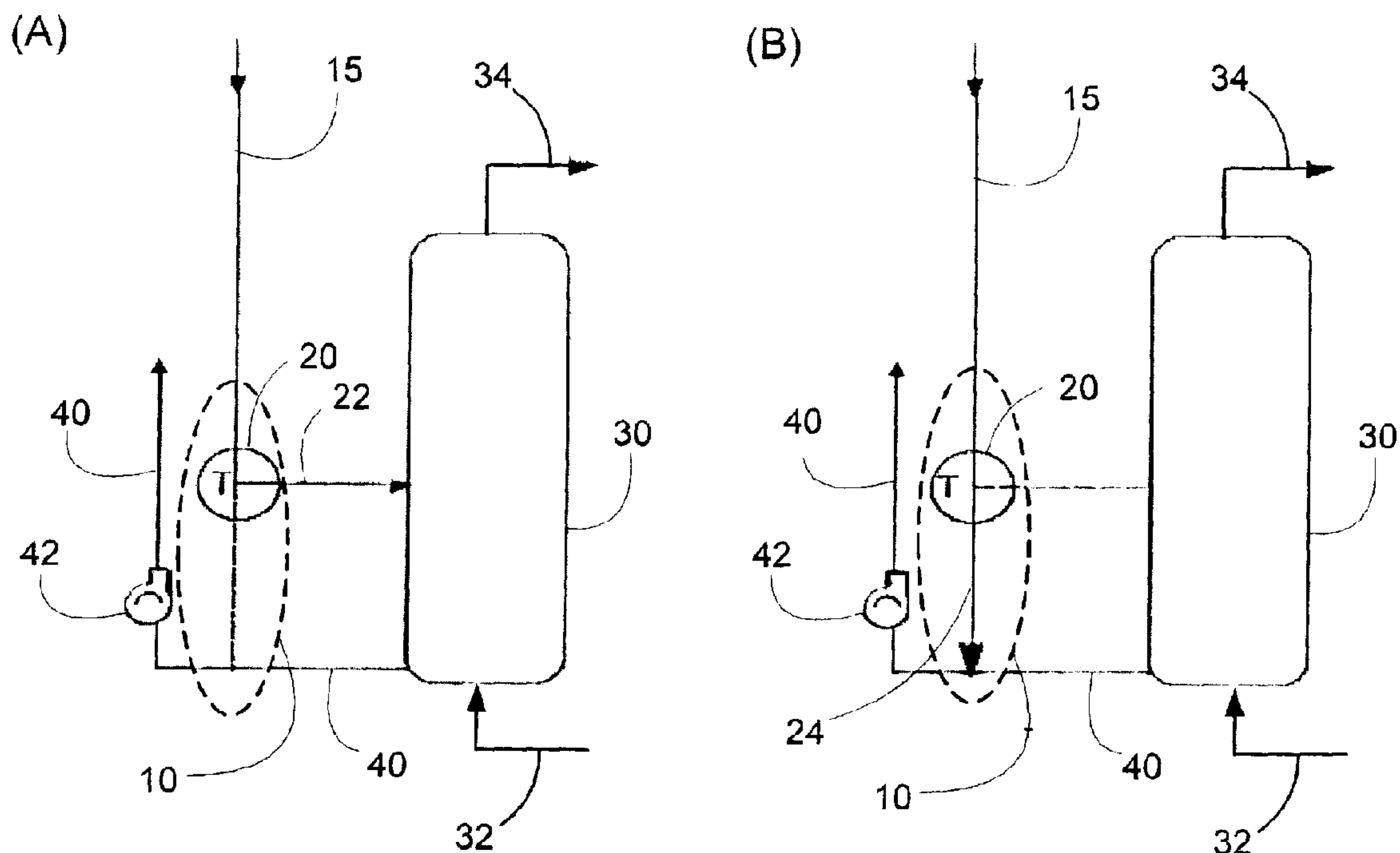

(86) Date de dépôt PCT/PCT Filing Date: 2012/02/08
 (87) Date publication PCT/PCT Publication Date: 2012/08/16
 (45) Date de délivrance/Issue Date: 2014/01/14
 (85) Entrée phase nationale/National Entry: 2013/07/10
 (86) N° demande PCT/PCT Application No.: CA 2012/000132
 (87) N° publication PCT/PCT Publication No.: 2012/106813
 (30) Priorité/Priority: 2011/02/08 (US61/440,811)

(51) Cl.Int./Int.Cl. *F24J 2/40* (2006.01)
 (72) Inventeur/Inventor:
 JACKMAN, TOM, CA
 (73) Propriétaire/Owner:
 TRATHOM CORPORATION, CA
 (74) Agent: GOWLING LAFLEUR HENDERSON LLP

(54) Titre : SYSTEME DE CAPTAGE D'ENERGIE SOLAIRE THERMIQUE A PROTECTION CONTRE LA SURCHAUFFE ET DERIVATION DE TEMPERATURE FROIDE
 (54) Title: SOLAR THERMAL ENERGY CAPTURE SYSTEM WITH OVERHEATING PROTECTION AND COLD TEMPERATURE BYPASS



(57) Abrégé/Abstract:

A thermoregulation apparatus for a solar thermal energy capture system comprising a piping infrastructure in fluid communication with a fluid storage tank and one or more solar thermal energy collectors. The thermoregulation apparatus comprises: (i) a thermostatically actuated valve interposed the piping infrastructure downstream from the one or more solar energy collectors and upstream from the fluid storage tank, and (ii) piping for interconnecting the thermostatically actuated valve with the piping infrastructure, and the fluid storage tank. The thermostatically actuated valve can be configured for diverting the flow of working fluid away from the fluid storage tank when the temperature of the working fluid is below a selected set point for actuating the valve, and for diverting the flow of working fluid to the fluid storage tank when the temperature of the working fluid is about or greater than the selected set point.



(12) INTERNATIONAL APPLICATION PUBLISHED UNDER THE PATENT COOPERATION TREATY (PCT)

(19) World Intellectual Property
Organization
International Bureau(10) International Publication Number
WO 2012/106813 A1(43) International Publication Date
16 August 2012 (16.08.2012)(51) International Patent Classification:
F24J 2/40 (2006.01)

(21) International Application Number:

PCT/CA2012/000132

(22) International Filing Date:

8 February 2012 (08.02.2012)

(25) Filing Language:

English

(26) Publication Language:

English

(30) Priority Data:

61/440,811 8 February 2011 (08.02.2011) US

(71) Applicant (for all designated States except US):
TRATHOM CORPORATION [CA/CA]; 12316 Lake
Moraine Rise SE, Calgary, Alberta T2J 2Z2 (CA).

(72) Inventor; and

(75) Inventor/Applicant (for US only): **JACKMAN, Tom**
[CA/CA]; 1301 - 16th Avenue, Calgary, Alberta T2M 0L4
(CA).(74) Agents: **POLONENKO, Daniel R.** et al.; Gowling Lafleur
Henderson LLP, P.O. Box 30, Suite 2300, 550 Burrard
Street, Vancouver, British Columbia V6C 1 B5 (CA).(81) Designated States (unless otherwise indicated, for every
kind of national protection available): AE, AG, AL, AM,
AO, AT, AU, AZ, BA, BB, BG, BH, BR, BW, BY, BZ,
CA, CH, CL, CN, CO, CR, CU, CZ, DE, DK, DM, DO,
DZ, EC, EE, EG, ES, FI, GB, GD, GE, GH, GM, GT, HN,
HR, HU, ID, IL, IN, IS, JP, KE, KG, KM, KN, KP, KR,
KZ, LA, LC, LK, LR, LS, LT, LU, LY, MA, MD, ME,
MG, MK, MN, MW, MX, MY, MZ, NA, NG, NI, NO, NZ,
OM, PE, PG, PH, PL, PT, QA, RO, RS, RU, RW, SC, SD,
SE, SG, SK, SL, SM, ST, SV, SY, TH, TJ, TM, TN, TR,
TT, TZ, UA, UG, US, UZ, VC, VN, ZA, ZM, ZW.(84) Designated States (unless otherwise indicated, for every
kind of regional protection available): ARIPO (BW, GH,
GM, KE, LR, LS, MW, MZ, NA, RW, SD, SL, SZ, TZ,
UG, ZM, ZW), Eurasian (AM, AZ, BY, KG, KZ, MD, RU,
TJ, TM), European (AL, AT, BE, BG, CH, CY, CZ, DE,
DK, EE, ES, FI, FR, GB, GR, HR, HU, IE, IS, IT, LT, LU,
LV, MC, MK, MT, NL, NO, PL, PT, RO, RS, SE, SI, SK,
SM, TR), OAPI (BF, BJ, CF, CG, CI, CM, GA, GN, GQ,
GW, ML, MR, NE, SN, TD, TG).**Published:**

— with international search report (Art. 21(3))

(54) Title: SOLAR THERMAL ENERGY CAPTURE SYSTEM WITH OVERHEATING PROTECTION AND COLD TEMPERATURE BYPASS

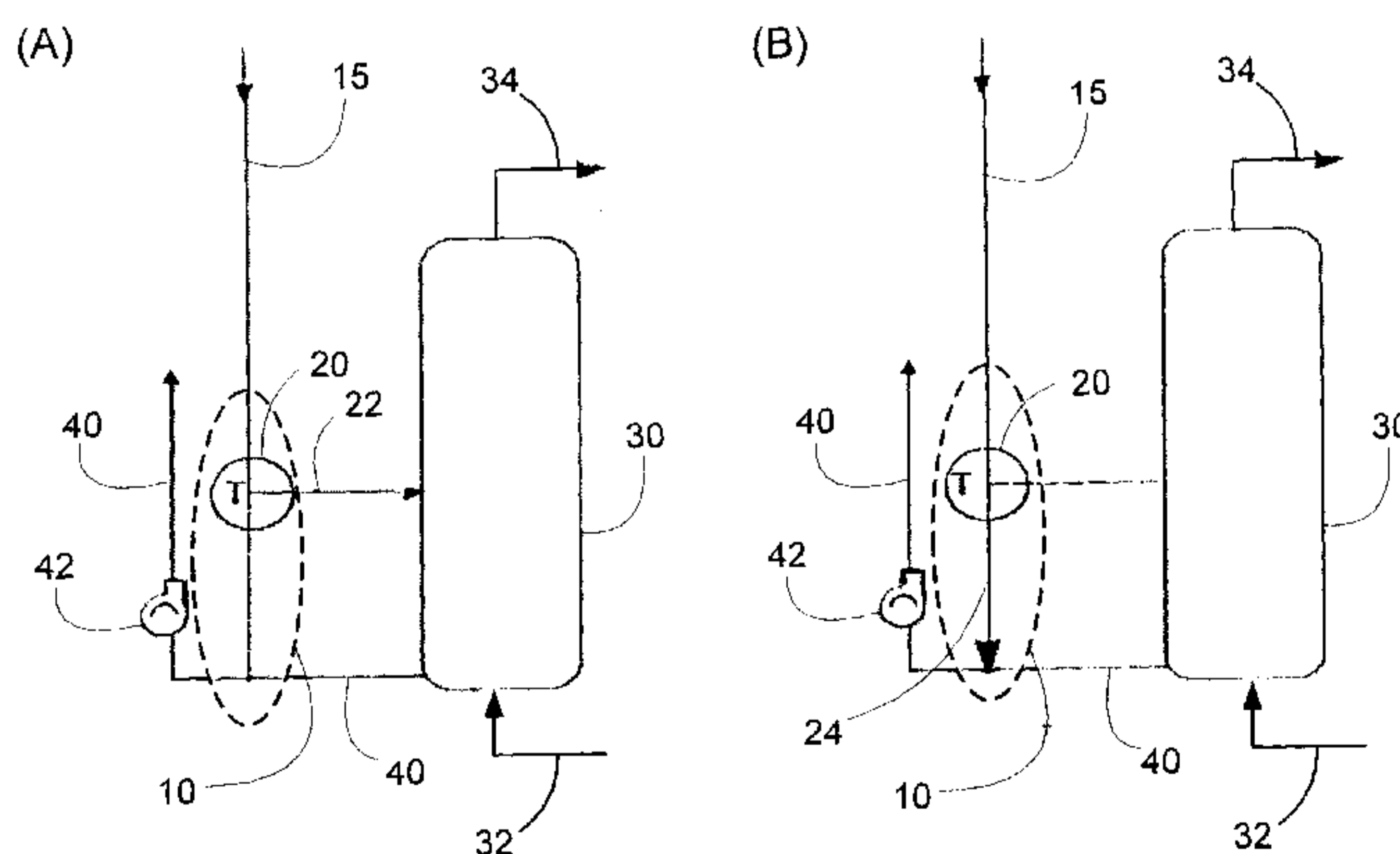

Fig. 1

(57) Abstract: A thermoregulation apparatus for a solar thermal energy capture system comprising a piping infrastructure in fluid communication with a fluid storage tank and one or more solar thermal energy collectors. The thermoregulation apparatus comprises: (i) a thermostatically actuated valve interposed the piping infrastructure downstream from the one or more solar energy collectors and upstream from the fluid storage tank, and (ii) piping for interconnecting the thermostatically actuated valve with the piping infrastructure, and the fluid storage tank. The thermostatically actuated valve can be configured for diverting the flow of working fluid away from the fluid storage tank when the temperature of the working fluid is below a selected set point for actuating the valve, and for diverting the flow of working fluid to the fluid storage tank when the temperature of the working fluid is about or greater than the selected set point.

- 1 -

TITLE: SOLAR THERMAL ENERGY CAPTURE SYSTEM WITH
OVERHEATING PROTECTION AND COLD TEMPERATURE BYPASS

FIELD:

The present disclosure relates to systems and apparatus for solar thermal energy
capture and more particularly, to systems and apparatus for controlling flow of fluids through
solar thermal energy capture and/or heat exchange systems.

BACKGROUND:

The use of solar radiation for heating fluids, such as water, has been known for many
years. Modern solar heating systems incorporated into buildings typically include one or
more solar energy collector panels suitable for absorbing energy from the sun wherein the
solar energy is converted into thermal energy transferred to fluids circulating therethrough
and which subsequently circulate throughout the buildings for heating purposes or for
storage.

Solar energy collector panels are generally installed on the roofs of buildings. A small
residential home will typically require a solar system having at least about three or four
square metres of solar energy collection surface area to supplement domestic water heating.
A home that also uses solar energy for space heating or other heating applications will
typically require ten to twenty square meters of collection surface area whereas an industrial
or commercial facility may need thirty square metres or more depending on the solar heating
application.

Solar collector panels are usually mounted flat on roofs to be the least obtrusive to the
overall appearance of the building. Such configurations do not maximize the amounts of solar
energy that may be captured by the collectors. In more northern regions, the solar energy
collectors should be tilted up towards the southern horizon, and in more southern regions,
they should be tilted up towards the northern horizon. Tilting solar collector panels increases
the capture of solar energy in winter months, but this can cause wind load problems,
especially with flat-plate collectors. Evacuated-tube collectors are not as prone to wind
loading due to spacing provided between the tubes. Tilting of the solar energy collector

- 2 -

panels, however, results in prominent views of the solar energy collectors which may be undesirable. One solution has been to mount the solar energy collectors on a south-facing wall (in northern hemispheres). Such installations are possible during new building construction, but may be difficult or impossible for retrofitting existing buildings. Other solutions for mitigating the visual prominence of solar collector panels are achieved by architecturally integrating the collector area into the building structure. Examples of architecturally integrated solar collectors include window shutters, balcony railings, awnings, 5
5
6
7
8
9
10
11
12
13
14
15
16
17
18
19
20
21
22
23
24
25
26
27
28
29
30
31
32
33
34
35
36
37
38
39
40
41
42
43
44
45
46
47
48
49
50
51
52
53
54
55
56
57
58
59
60
61
62
63
64
65
66
67
68
69
70
71
72
73
74
75
76
77
78
79
80
81
82
83
84
85
86
87
88
89
90
91
92
93
94
95
96
97
98
99
100
101
102
103
104
105
106
107
108
109
110
111
112
113
114
115
116
117
118
119
120
121
122
123
124
125
126
127
128
129
130
131
132
133
134
135
136
137
138
139
140
141
142
143
144
145
146
147
148
149
150
151
152
153
154
155
156
157
158
159
160
161
162
163
164
165
166
167
168
169
170
171
172
173
174
175
176
177
178
179
180
181
182
183
184
185
186
187
188
189
190
191
192
193
194
195
196
197
198
199
200
201
202
203
204
205
206
207
208
209
210
211
212
213
214
215
216
217
218
219
220
221
222
223
224
225
226
227
228
229
230
231
232
233
234
235
236
237
238
239
240
241
242
243
244
245
246
247
248
249
250
251
252
253
254
255
256
257
258
259
260
261
262
263
264
265
266
267
268
269
270
271
272
273
274
275
276
277
278
279
280
281
282
283
284
285
286
287
288
289
290
291
292
293
294
295
296
297
298
299
300
301
302
303
304
305
306
307
308
309
310
311
312
313
314
315
316
317
318
319
320
321
322
323
324
325
326
327
328
329
330
331
332
333
334
335
336
337
338
339
340
341
342
343
344
345
346
347
348
349
350
351
352
353
354
355
356
357
358
359
360
361
362
363
364
365
366
367
368
369
370
371
372
373
374
375
376
377
378
379
380
381
382
383
384
385
386
387
388
389
390
391
392
393
394
395
396
397
398
399
400
401
402
403
404
405
406
407
408
409
410
411
412
413
414
415
416
417
418
419
420
421
422
423
424
425
426
427
428
429
430
431
432
433
434
435
436
437
438
439
440
441
442
443
444
445
446
447
448
449
450
451
452
453
454
455
456
457
458
459
460
461
462
463
464
465
466
467
468
469
470
471
472
473
474
475
476
477
478
479
480
481
482
483
484
485
486
487
488
489
490
491
492
493
494
495
496
497
498
499
500
501
502
503
504
505
506
507
508
509
510
511
512
513
514
515
516
517
518
519
520
521
522
523
524
525
526
527
528
529
530
531
532
533
534
535
536
537
538
539
540
541
542
543
544
545
546
547
548
549
550
551
552
553
554
555
556
557
558
559
560
561
562
563
564
565
566
567
568
569
570
571
572
573
574
575
576
577
578
579
580
581
582
583
584
585
586
587
588
589
590
591
592
593
594
595
596
597
598
599
600
601
602
603
604
605
606
607
608
609
610
611
612
613
614
615
616
617
618
619
620
621
622
623
624
625
626
627
628
629
630
631
632
633
634
635
636
637
638
639
640
641
642
643
644
645
646
647
648
649
650
651
652
653
654
655
656
657
658
659
660
661
662
663
664
665
666
667
668
669
670
671
672
673
674
675
676
677
678
679
680
681
682
683
684
685
686
687
688
689
690
691
692
693
694
695
696
697
698
699
700
701
702
703
704
705
706
707
708
709
710
711
712
713
714
715
716
717
718
719
720
721
722
723
724
725
726
727
728
729
730
731
732
733
734
735
736
737
738
739
740
741
742
743
744
745
746
747
748
749
750
751
752
753
754
755
756
757
758
759
760
761
762
763
764
765
766
767
768
769
770
771
772
773
774
775
776
777
778
779
780
781
782
783
784
785
786
787
788
789
790
791
792
793
794
795
796
797
798
799
800
801
802
803
804
805
806
807
808
809
810
811
812
813
814
815
816
817
818
819
820
821
822
823
824
825
826
827
828
829
830
831
832
833
834
835
836
837
838
839
840
841
842
843
844
845
846
847
848
849
850
851
852
853
854
855
856
857
858
859
860
861
862
863
864
865
866
867
868
869
870
871
872
873
874
875
876
877
878
879
880
881
882
883
884
885
886
887
888
889
890
891
892
893
894
895
896
897
898
899
900
901
902
903
904
905
906
907
908
909
910
911
912
913
914
915
916
917
918
919
920
921
922
923
924
925
926
927
928
929
930
931
932
933
934
935
936
937
938
939
940
941
942
943
944
945
946
947
948
949
950
951
952
953
954
955
956
957
958
959
960
961
962
963
964
965
966
967
968
969
970
971
972
973
974
975
976
977
978
979
980
981
982
983
984
985
986
987
988
989
990
991
992
993
994
995
996
997
998
999
1000
1001
1002
1003
1004
1005
1006
1007
1008
1009
1010
1011
1012
1013
1014
1015
1016
1017
1018
1019
1020
1021
1022
1023
1024
1025
1026
1027
1028
1029
1030
1031
1032
1033
1034
1035
1036
1037
1038
1039
1040
1041
1042
1043
1044
1045
1046
1047
1048
1049
1050
1051
1052
1053
1054
1055
1056
1057
1058
1059
1060
1061
1062
1063
1064
1065
1066
1067
1068
1069
1070
1071
1072
1073
1074
1075
1076
1077
1078
1079
1080
1081
1082
1083
1084
1085
1086
1087
1088
1089
1090
1091
1092
1093
1094
1095
1096
1097
1098
1099
1100
1101
1102
1103
1104
1105
1106
1107
1108
1109
1110
1111
1112
1113
1114
1115
1116
1117
1118
1119
1120
1121
1122
1123
1124
1125
1126
1127
1128
1129
1130
1131
1132
1133
1134
1135
1136
1137
1138
1139
1140
1141
1142
1143
1144
1145
1146
1147
1148
1149
1150
1151
1152
1153
1154
1155
1156
1157
1158
1159
1160
1161
1162
1163
1164
1165
1166
1167
1168
1169
1170
1171
1172
1173
1174
1175
1176
1177
1178
1179
1180
1181
1182
1183
1184
1185
1186
1187
1188
1189
1190
1191
1192
1193
1194
1195
1196
1197
1198
1199
1200
1201
1202
1203
1204
1205
1206
1207
1208
1209
1210
1211
1212
1213
1214
1215
1216
1217
1218
1219
1220
1221
1222
1223
1224
1225
1226
1227
1228
1229
1230
1231
1232
1233
1234
1235
1236
1237
1238
1239
1240
1241
1242
1243
1244
1245
1246
1247
1248
1249
1250
1251
1252
1253
1254
1255
1256
1257
1258
1259
1260
1261
1262
1263
1264
1265
1266
1267
1268
1269
1270
1271
1272
1273
1274
1275
1276
1277
1278
1279
1280
1281
1282
1283
1284
1285
1286
1287
1288
1289
1290
1291
1292
1293
1294
1295
1296
1297
1298
1299
1300
1301
1302
1303
1304
1305
1306
1307
1308
1309
1310
1311
1312
1313
1314
1315
1316
1317
1318
1319
1320
1321
1322
1323
1324
1325
1326
1327
1328
1329
1330
1331
1332
1333
1334
1335
1336
1337
1338
1339
1340
1341
1342
1343
1344
1345
1346
1347
1348
1349
1350
1351
1352
1353
1354
1355
1356
1357
1358
1359
1360
1361
1362
1363
1364
1365
1366
1367
1368
1369
1370
1371
1372
1373
1374
1375
1376
1377
1378
1379
1380
1381
1382
1383
1384
1385
1386
1387
1388
1389
1390
1391
1392
1393
1394
1395
1396
1397
1398
1399
1400
1401
1402
1403
1404
1405
1406
1407
1408
1409
1410
1411
1412
1413
1414
1415
1416
1417
1418
1419
1420
1421
1422
1423
1424
1425
1426
1427
1428
1429
1430
1431
1432
1433
1434
1435
1436
1437
1438
1439
1440
1441
1442
1443
1444
1445
1446
1447
1448
1449
1450
1451
1452
1453
1454
1455
1456
1457
1458
1459
1460
1461
1462
1463
1464
1465
1466
1467
1468
1469
1470
1471
1472
1473
1474
1475
1476
1477
1478
1479
1480
1481
1482
1483
1484
1485
1486
1487
1488
1489
1490
1491
1492
1493
1494
1495
1496
1497
1498
1499
1500
1501
1502
1503
1504
1505
1506
1507
1508
1509
1510
1511
1512
1513
1514
1515
1516
1517
1518
1519
1520
1521
1522
1523
1524
1525
1526
1527
1528
1529
1530
1531
1532
1533
1534
1535
1536
1537
1538
1539
1540
1541
1542
1543
1544
1545
1546
1547
1548
1549
1550
1551
1552
1553
1554
1555
1556
1557
1558
1559
1560
1561
1562
1563
1564
1565
1566
1567
1568
1569
1570
1571
1572
1573
1574
1575
1576
1577
1578
1579
1580
1581
1582
1583
1584
1585
1586
1587
1588
1589
1590
1591
1592
1593
1594
1595
1596
1597
1598
1599
1600
1601
1602
1603
1604
1605
1606
1607
1608
1609
1610
1611
1612
1613
1614
1615
1616
1617
1618
1619
1620
1621
1622
1623
1624
1625
1626
1627
1628
1629
1630
1631
1632
1633
1634
1635
1636
1637
1638
1639
1640
1641
1642
1643
1644
1645
1646
1647
1648
1649
1650
1651
1652
1653
1654
1655
1656
1657
1658
1659
1660
1661
1662
1663
1664
1665
1666
1667
1668
1669
1670
1671
1672
1673
1674
1675
1676
1677
1678
1679
1680
1681
1682
1683
1684
1685
1686
1687
1688
1689
1690
1691
1692
1693
1694
1695
1696
1697
1698
1699
1700
1701
1702
1703
1704
1705
1706
1707
1708
1709
1710
1711
1712
1713
1714
1715
1716
1717
1718
1719
1720
1721
1722
1723
1724
1725
1726
1727
1728
1729
1730
1731
1732
1733
1734
1735
1736
1737
1738
1739
1740
1741
1742
1743
1744
1745
1746
1747
1748
1749
1750
1751
1752
1753
1754
1755
1756
1757
1758
1759
1760
1761
1762
1763
1764
1765
1766
1767
1768
1769
1770
1771
1772
1773
1774
1775
1776
1777
1778
1779
1780
1781
1782
1783
1784
1785
1786
1787
1788
1789
1790
1791
1792
1793
1794
1795
1796
1797
1798
1799
1800
1801
1802
1803
1804
1805
1806
1807
1808
1809
1810
1811
1812
1813
1814
1815
1816
1817
1818
1819
1820
1821
1822
1823
1824
1825
1826
1827
1828
1829
1830
1831
1832
1833
1834
1835
1836
1837
1838
1839
1840
1841
1842
1843
1844
1845
1846
1847
1848
1849
1850
1851
1852
1853
1854
1855
1856
1857
1858
1859
1860
1861
1862
1863
1864
1865
1866
1867
1868
1869
1870
1871
1872
1873
1874
1875
1876
1877
1878
1879
1880
1881
1882
1883
1884
1885
1886
1887
1888
1889
1890
1891
1892
1893
1894
1895
1896
1897
1898
1899
1900
1901
1902
1903
1904
1905
1906
1907
1908
1909
1910
1911
1912
1913
1914
1915
1916
1917
1918
1919
1920
1921
1922
1923
1924
1925
1926
1927
1928
1929
1930
1931
1932
1933
1934
1935
1936
1937
1938
1939
1940
1941
1942
1943
1944
1945
1946
1947
1948
1949
1950
1951
1952
1953
1954
1955
1956
1957
1958
1959
1960
1961
1962
1963
1964
1965
1966
1967
1968
1969
1970
1971
1972
1973
1974
1975
1976
1977
1978
1979
1980
1981
1982
1983
1984
1985
1986
1987
1988
1989
1990
1991
1992
1993
1994
1995
1996
1997
1998
1999
2000
2001
2002
2003
2004
2005
2006
2007
2008
2009
2010
2011
2012
2013
2014
2015
2016
2017
2018
2019
2020
2021
2022
2023
2024
2025
2026
2027
2028
2029
2030
2031
2032
2033
2034
2035
2036
2037
2038
2039
2040
2041
2042
2043
2044
2045
2046
2047
2048
2049
2050
2051
2052
2053
2054
2055
2056
2057
2058
2059
2060
2061
2062
2063
2064
2065
2066
2067
2068
2069
2070
2071
2072
2073
2074
2075
2076
2077
2078
2079
2080
2081
2082
2083
2084
2085
2086
2087
2088
2089
2090
2091
2092
2093
2094
2095
2096
2097
2098
2099
2100
2101
2102
2103
2104
2105
2106
2107
2108
2109
2110
2111
2112
2113
2114
2115
2116
2117
2118
2119
2120
2121
2122
2123
2124
2125
2126
2127
2128
2129
2130
2131
2132
2133
2134
2135
2136
2137
2138
2139
2140
2141
2142
2143
2144
2145
2146
2147
2148
2149
2150
2151
2152
2153
2154
2155
2156
2157
2158
2159
2160
2161
2162
2163
2164
2165
2166
2167
2168
2169
2170
2171
2172
2173
2174
2175
2176
2177
2178
2179
2180
2181
2182
2183
2184
2185
2186
2187
2188
2189
2190
2191
2192
2193
2194
2195
2196
2197
2198
219

- 3 -

connected to the water tank by a piping infrastructure. Working fluids used in the indirect systems typically are provided with antifreeze agents.

The above classification of solar water heaters also applies to solar heaters used in other heating applications such as pool heating, space heating, process heating or any other application where heating a fluid is desired. In all cases a fluid heated by solar energy collector panels is used directly or indirectly to provide heat energy.

Conventional solar heating systems are usually configured to enable stoppage of the circulation of the potable water or working fluid through the piping infrastructure connected to the solar energy collector panels, the water storage tanks and the heat exchange units during periods of low or no solar irradiation in order to avoid the loss of thermal energy that has been previously captured by the solar collector panels and reduce unnecessary pump operation costs. Some systems use a “drain-back” approach to drain the working fluid into a holding tank during shutdown periods. Non-“drain-back” systems require the addition of sufficient anti-freeze agent to ensure working fluids do not freeze and cause physical damage to the piping and/or the solar energy collector panels. Regardless of the shutdown strategy used, the working fluids cool significantly during idle periods and have to be re-heated once the system starts operating. This results in inefficient operation during the first few minutes or hours of operation of the solar thermal energy capture systems depending on how low the ambient temperatures become and the quantity of working fluid in the solar heating system. It is a particular problem in cold climates where overnight temperature drop significantly below freezing.

Solar thermal energy capture systems must also be configured to prevent damage that may be caused by excessive heat build-up during periods of high solar energy. Control methods are necessary to mitigate damage from high-temperature fluid flowing through either or both of the working fluid side and the load side of the heat exchange units and piping infrastructure. Additionally, as a fail-safe precaution, allowances must be made for relief of pressure that may accumulate through excessive heat on the working fluid side caused by extended intense solar radiation. Strategies used for controlling overheating in conventional solar thermal energy capture systems include among others: (i) “heat dumps” which are a remote heat application where unwanted heat is dumped such as under an outdoor patio; (ii) draining back and shutting down the system and permitting the solar collectors to stagnate; (iii) manually setting the system controller to a “vacation” setting

- 4 -

when the primary application is not required, as is the case when a homeowner with a solar water heater goes on vacation, which activates a control sequence to avoid over heating such as by circulating the working fluid through the collectors over night to increase heat losses; or (iv) deliberately under-sizing the system such that the system's peak output provides 90% of the minimum anticipated heat load, which means that other energy providers exemplified by gas utilities and electric utilities, must be relied upon as supplemental heating sources.

Consequently, conventional systems configurations for solar thermal energy capture have become fairly complex. Some systems are designed to have multiple fluid circuits wherein one circuit is dedicated for dissipation of excess heat energy. Other strategies employ complex piping infrastructures with separate heat dissipater circuits for cooling overheated working fluid exiting the solar energy collector panels. With such systems, all of the working fluid is heated by the solar panels and then cooled after egress resulting in system inefficiencies.

Most conventional solar thermal energy capture systems incorporate electronic control systems for activating or de-activating the fluid circulation pumps and valves to enable control over and manipulation of fluid flow throughout the system, filling or imposing drain-backs, directing working fluid through solar collector panels and heat exchange units, or for activating over-heating mitigation mechanisms. These control and operating systems require electrical energy usually supplied by an electric utility company. Electrical power interruptions will result in loss of control over the solar thermal energy capture system that could result in physical damage to the system, and in collateral damage to the building in the event that the piping infrastructure fails. One solution to ensure electrical power supply has been to use battery backups. In some systems, solar photovoltaic (PV) systems are available to supply the necessary electrical energy either directly to the solar heating system and controller, or indirectly, such as battery packs and the like. However, battery systems have a relatively short life expectancy. Moreover, failure to test and replace the battery can lead to the same type of damage as seen with loss of electrical power. Furthermore, the electronic control methods are prone to component failures, particularly within the twenty- to thirty-year life expectancy of solar collector systems.

- 5 -

SUMMARY:

The exemplary embodiments of the present invention relate to solar fluid heat exchange systems.

One embodiment of the present invention relates to a thermoregulation apparatus of a direct solar fluid heat exchange system. The heat exchange system comprises a piping infrastructure that is in fluid communication with: (a) one or more solar energy collectors; (b) a fluid storage tank; and (c) a thermostatic valve. The working fluid circulates through the piping infrastructure to be heated by the solar energy collectors, which harness solar energy from the sun. The working fluid thereafter circulates to the fluid storage tank. The thermoregulation apparatus comprises a thermostatic valve and operates to regulate the flow of the working fluid. The thermostatic valve is configured to divert the flow of the working fluid away from the fluid storage tank and back to the solar energy collectors for heating if the temperature of the working fluid is below a preset minimum temperature.

In the case of an indirect solar fluid heat exchange system, the system comprises a piping infrastructure that is in fluid communication with: (a) one or more solar energy collectors; (b) a fluid heat exchanger; and (c) a thermostatic valve. The working fluid circulates through the piping infrastructure to be heated by the solar energy collectors and thereafter circulates to the fluid heat exchanger. The thermoregulation apparatus comprises a thermostatic valve and operates to regulate the flow of the working fluid. The thermostatic valve is configured to divert the flow of the working fluid away from the fluid heat exchanger and back to the solar energy collectors for heating if the temperature of the working fluid is below a preset minimum temperature.

Another embodiment of the present invention relates to a solar fluid heat exchange system comprising both a minimum-temperature thermoregulation apparatus and a maximum-temperature thermoregulation device managing the flow of working fluid through the solar fluid heat exchange system. In the indirect solar heating system, the heat exchange system comprises: a piping infrastructure in fluid communication with one or more solar energy collectors, a fluid heat exchanger, a heat dissipater, and two control valves. The high temperature control valve is positioned downstream of the solar energy collectors and the heat dissipater. This control valve substantially continuously monitors the temperature,

- 6 -

pressure or other condition of the system that can be indicative of overheating while the system is in operation. If the control valve senses overheating, at least a portion of the working fluid is mixed with cooler fluid that has traversed the parallel heat dissipater in order to decrease the temperature of the working fluid and avoid overheating the system. When the

5 temperature (or pressure or other condition) of the working fluid returns to the normal operating range, the mixing stops and all the working fluid traverses directly from the solar energy collectors to the fluid heat exchanger. The low temperature valve is positioned downstream of the solar energy collectors and upstream of the fluid heat exchanger. This control valve is configured to divert cold working fluid away from the normal flow into the

10 fluid heat exchanger and instead back to the solar energy collectors for continued heating, in order to increase the efficiency of the heating exchange system. When the working fluid is heated to the low temperature valve's setpoint the normal flow into the storage tank is resumed. The heat exchange system further comprises a solar-powered pump for pumping the working fluid through the piping infrastructure during a period of solar energy collection.

15 When the above embodiment of the invention is applied to a direct solar heating system the fluid heat exchanger is replaced by a fluid storage tank or reservoir.

The one or more solar energy collectors may be evacuated-tube heat pipe collectors, flat-plate solar energy collectors, or any other type of solar thermal collector or panel for absorbing solar energy from the sun.

20 The one or more solar energy collectors are sized for maximum solar energy absorption, not under-sized to avoid overheating.

The solar-powered pump is preferably powered by a photovoltaic panel such that the system is independent from an electric utility grid and any other external energy provider.

25 The one or more solar energy collectors may function as balusters of a solar balustrade or other railing system or protective railing. Such an aspect of the present invention provides a solar heating system that functions as both a protective railing or guard and a solar energy collector.

According to one aspect, the heat exchange system may further comprise an expansion tank to accommodate increases in the volume of the working fluid.

- 7 -

According to another aspect, a pressure relief valve may be incorporated in the heat exchange system to release working fluid from the piping infrastructure in the event of a failure of the control valve, the solar pump or a vapor lock within the system

5 According to another aspect, the piping infrastructure of the heat exchange system may further comprise fill and drain valves to facilitate loading of the piping infrastructure with the working fluid and to allow access to the working fluid to test the conditions of the working fluid.

This summary does not necessarily describe all features of the invention. Other aspects, features and advantages of the invention will be apparent to those of ordinary skill in
10 the art upon review of the following description of specific embodiments of the invention.

BRIEF DESCRIPTION OF THE DRAWINGS:

Figs. 1(A) and 1(B) are schematic diagrams of an exemplary embodiment of the present invention operating to thermostatically control the flow of working fluid from a solar energy collector panel to a heat exchange unit (Fig. 1(A)), or to bypass the heat exchange unit
15 (Fig. 1(B));

Fig. 2 is a schematic diagram of an exemplary solar thermal energy capture system comprising an exemplary thermoregulation apparatus of the present invention;

Fig. 3 is a schematic diagram of the solar thermal energy capture system from Fig. 2, additionally comprising a heat dissipater;

20 Fig. 4 is a schematic diagram of the solar thermal energy capture system from Fig. 3, showing the heat exchange unit physically separated from hot water storage tank;

Fig. 5 is a chart showing the temperature changes in working fluid flowing into a solar energy collector panel (dark grey squares), working fluid flowing out of the solar energy collector panel (black diamonds), and the working fluid at the inlet to a water storage tank
25 (light grey triangles), and the rate of flow of the working fluid in the solar energy thermal energy capture system (solid black line) at an ambient temperature of -12° C (10 am reading); and

- 8 -

Fig. 6 is a chart showing the temperature changes in working fluid flowing into a solar energy collector panel (dark grey squares), working fluid flowing out of the solar energy collector panel (black diamonds), and the working fluid at the inlet to a water storage tank (light grey triangles), and the rate of flow of the working fluid in the solar energy thermal energy capture system (solid black line) at an ambient starting temperature of +12° C (10 am reading).

DETAILED DESCRIPTION:

The exemplary embodiments of the present invention relate to apparatus and systems for thermostatic regulation of the circulation of working fluids throughout solar thermal energy capture systems. The thermoregulation apparatus and systems are suitable for integration into systems designs for new installations of solar thermal energy capture systems.

One exemplary embodiment relates to an apparatus that comprises a thermostatically actuated valve with: (a) ingressing piping interconnected to a piping infrastructure communicating with an egressing flow of working fluid from one or more solar energy collector panels, and (b) a first egressing piping interconnected with a piping infrastructure communicating with one side of a heat exchange unit receiving a flow of potable water or alternatively, a non-potable fluid supply exemplified by water containing anti-freeze solutions, oils and the like, from its other side, and (c) a second egressing piping interconnected with piping infrastructure communicating with the ingressing inlets of the one or more solar energy collector panels. When the temperature of the working fluid is about or higher than its selected temperature set point, the thermostatically actuated valve diverts the flow of working fluid egressing from the solar energy collector panels to the piping infrastructure communicating with the heat exchange unit. When the temperature of the working fluid is lower than about its selected temperature set point, the thermostatically actuated valve diverts the flow of working fluid egressing from the solar energy collector panels to the piping infrastructure communicating with the ingressing inlets of the one or more solar energy collector panels. It is suitable to select a thermostatically actuated valve that may optionally (a) completely divert the flow of working fluid into piping ingressing into the heat exchange unit, (b) completely divert the flow of working fluid into the piping infrastructure communicating with the ingress inlets of the solar energy collector panels, or

- 9 -

(c) divert some of the working fluid flow into piping ingressing into the heat exchange unit and divert the rest of the working fluid flow into the piping infrastructure communicating with the ingress inlets of the solar energy collector panels. The apparatus can be integrated into new systems designs for solar thermal energy capture systems for new installations.

5 Alternatively the apparatus may comprise a thermostatically actuated valve provided with an ingressing piping component and a pair of egressing piping components suitable for retrofitting into an operational solar thermal energy capture system. It is optional to provide the apparatus components in kits for installation into new systems or for retrofitting into previously installed systems.

10 Fig 1(A) is a schematic diagram showing the apparatus 10 of the present invention interposed an exemplary solar energy collection system. Line 15 egressing working fluid from a solar energy collector panel (not shown) ingresses thermostatically controlled valve 20. The thermostatically controlled valve 20 diverts the flow of working fluid into line 22 ingressing a heat exchange unit 30 that receives inflowing potable water through line 32. Heat is transferred from the working fluid in line 22 to the potable water flowing through line 15 32. Heated potable water egresses the heat exchange unit 30 via line 34, while the cooled working fluid egresses from the heat exchange unit 30 through line 40 returning to the solar energy collector panel (not shown). Pump 42 is interposed line 40 to maintain circulation of the working fluid through the solar thermal energy capture system. When the working fluid 20 ingressing the thermostatically controlled valve 20 is below the set point, the thermostatically controlled valve 20 diverts the flow of the working fluid into line 24 that interconnects line 40 returning to the solar energy collector panel (Fig. 1 (B)). It is to be noted that in the exemplary system illustrated in Figs. 1(A) and 1(B), the heat-exchange unit 30 comprises: (i) a tank for storing the heated potable water or alternatively the heated non-potable fluid 25 supply, and (ii) a heat-exchange unit mounted inside the tank. A suitable thermostatically controlled valve is exemplified by the Therm-Omega-Tech model M/D temperature control valve designed for 3-way diverting of fluid flows (Therm-Omega-Tech Inc, Warminster, PA, USA). The M/D valve will divert or switch the flow of fluid to either of the two egressing ports depending on the working fluid temperature.

30 The control valves in the solar fluid heat exchange system may be thermo-static valves that respond to the temperature of the working fluid. These thermo-static valves require no electrical energy to operate and therefore, with the inclusion of a photo-voltaic

- 10 -

powered pumping system, the solar fluid heat exchange system can be 'off-grid' meaning independent of externally-supplied electrical energy. The control valves can also be electrically operated valves common in industry and residential heating systems. These valves require temperature sensors in critical areas and with signaling provided from a pre-programmed processor, direct fluid flows based on temperature readings detected by the temperature sensors. The processor in these cases can optionally use relative temperatures instead of absolute temperatures as in the case of thermo-static valves, to direct the flow of the working fluid. For example, the low temperature control valve can divert the working fluid back to the solar collector until the working fluid is higher than the temperature of the storage tank.

Another exemplary embodiment relates to solar thermal energy capture systems comprising an apparatus of the present invention interposed (a) piping egressing from one or more solar energy collector panels conveying working fluid to a heat exchange unit communicating with potable water on the other side, and (b) the heat exchange unit. One of the two piping infrastructures egressing from the thermostatically actuated valve comprising the apparatus, is interconnected with piping ingressing the heat exchange unit. The other piping infrastructure egressing from the thermostatically actuated valve, is interconnected with the piping infrastructure communicating with the ingress inlets of the solar energy collector panels.

Exemplary solar thermal energy capture systems of the present invention generally comprise: (a) a piping infrastructure; (b) one or more solar energy collector panels in fluid communication with the piping infrastructure; (c) a thermostatically actuated valve in fluid communication with the piping infrastructure, (d) a fluid storage tank or reservoir, and optionally (e) a heat exchange unit in fluid communication with the piping infrastructure and the thermostatically actuated valve. The piping infrastructure preferably comprises piping that is insulated or otherwise treated to minimize transfer of thermal energy from the working fluid circulating therein, to the ambient environment. A working fluid circulates through the piping infrastructure to be heated by the one or more solar energy collector panels, which thereafter circulates to the fluid storage tank. The thermoregulation apparatus operates as a cold temperature bypass for the heat exchange system to reduce the loss of efficiency of the heat exchange system when there is cold working fluid circulating through the piping infrastructure. This typically occurs when the solar thermal energy capture system first begins

- 11 -

operating each morning since the working fluid would have cooled substantially in the absence of solar irradiation of the solar energy collector panels. The thermoregulation apparatus comprises a thermostatically actuated valve configurable for diverting the fluid in piping infrastructure away from the heat storage unit and back to the one or more solar energy collector panels for heating if the temperature of the fluid is below a preset minimum operating temperature. Preferably the valve is a thermostatically actuated valve preset at a minimum operating temperature. A suitable minimum operating temperature may be selected based on one or more of ambient atmospheric conditions, ambient conditions inside the building structure, or the desired temperatures for diverting the flow of working fluid into the heat exchange unit. A suitable minimum operating temperature may be selected anywhere from the range of about 10° C to about 35°C, about 15° C to about 25°C, about 20° C to about 25°C for domestic water heating applications. Other heating applications may have other minimum temperatures. Without such a thermoregulation apparatus, cold fluid in the piping infrastructure would circulate into the heat exchange unit. The cold working fluid would absorb heat from the warmer potable water or heating load fluid circulating through the other side of the heat exchange unit thereby causing undesirable heat losses from the potable water or heating load fluid.

An exemplary solar thermal energy capture indirect system 100 is shown in Fig. 2 and comprises a solar energy collector panel 110 interconnected with a working fluid piping infrastructure 112 interconnected with the ingress inlet of a first thermostatically actuated valve 115. The first egress outlet of the first thermostatically actuated valve 115 is provided with piping 116 that is interconnected with the working fluid ingress inlet of a heat exchange unit (not shown) directly mounted onto or inside a hot water storage tank 121. The working fluid egress outlet of the heat exchange unit is interconnected with working fluid piping infrastructure 125 for return of cooled working fluid to the solar energy collection panel 110. The second egress outlet of the first thermostatically actuated valve 115 is provided with piping 117 that is interconnected with the working fluid piping infrastructure 125 for return of cooled working fluid to the solar energy collector panel 110. A pressure relief valve 148 is interposed piping 141. A pump 130 is provided interposed in the working fluid piping infrastructure 125 to enable manipulation of the rates of recirculation of the working fluid through working fluid piping infrastructures 112 and 125 for manipulable communication with the various components of the solar thermal energy capture system 100 on an “as need” basis. The pump 130 may be optionally powered by electricity generated by an optional

- 12 -

photovoltaic array 132 mounted in a suitable location on the exterior of the building for efficient solar irradiation. The photovoltaic array 132 communicates with the pump 130 by wiring 133. If desired, additional equipment may interposed in communication with working fluid piping infrastructure 125 as exemplified by a fill station 155 comprising two fill/drain valves, a fill control valve in between the two fill/drain valves, a visual flow meter and a pressure gauge, an expansion tank 150, and the like. The water side of the heat exchange unit is in communication with a piping infrastructure configured for distribution of potable water through out a building. Piping 122 supplies a flow of water into the ingress inlet of the heat exchange unit 120 mounted onto or inside the hot water storage tank 121. Thermal energy is transferred from the working fluid flowing through the working fluid side of the heat exchange unit 120 to the water flowing through or surrounding the water side of the heat exchange unit 120 thereby significantly increasing the water temperature that can be monitored by temperature gauge 120. The heated water is then stored in the hot water storage tank 121 until it is transferred into egress piping 124 for delivery throughout the building as required. An optional anti-scald valve 123 may be interposed in the egress piping 124 from the hot water storage tank 121 if so desired, to act as a safety device for ensuring water exiting the hot water storage tank 121 does not exceed safe temperatures for use elsewhere in the building.

The solar energy collector panels 110 incorporated into exemplary solar thermal energy capture systems of the present invention, may comprise fluid-conveying evacuated-tube pipe collectors. Alternatively, flat-plate solar energy collectors or any other type of solar thermal collector or panel suitable for absorbing solar irradiation and transferring it as thermal energy to circulating working fluid systems, may be incorporated into the exemplary solar thermal energy capture systems of the present invention.

The thermostatically actuated valve 115 is operable as a cold-temperature bypass control device. The thermostatically actuated valve 115 is interposed in the piping infrastructure 112 between the solar energy collector panels 110 and the heat exchange unit 120. Hot water generated by the heat exchange unit through transfer therein of thermal energy from the working fluid side to the water side, is stored in the hot water storage tank 121 until it is required at a "point of use" elsewhere in the building. The thermostatically actuated valve 115 is configurable to divert the flow of the working fluid to piping infrastructure 125 via piping 117 for recirculation to the solar energy collector panels 110 if

- 13 -

the working fluid is colder than the preset minimum operating temperature in the thermostatically actuated valve 115. When the temperature of the working fluid is about or greater than the preset minimum operating temperature for the thermostatically actuated valve 115, the valve 115 will partially or completely divert the flow of working fluid to the
5 heat exchange unit via piping 116, or alternatively if so configured, directly into the hot water storage tank 121.

The solar thermal energy capture system 100 further comprises a recirculating pump 130 for providing a flow of working fluid through piping infrastructures 125 and 112. Any type of pump suitable for modulating rates of fluid flow through piping infrastructures can be
10 used in the solar thermal energy capture system 100. An exemplary recirculating pump is a solar-energy powered pump receiving electricity generated by power produced by a photovoltaic array or panel 132 to remove reliance upon external electrical energy. The photovoltaic panel 132 may be integrated with the one or more solar energy collector panels 110 or may be installed in a location separated from the one or more solar energy collector
15 panels 110. Use of photovoltaic panels 132 as a source of power for the recirculating pump 130 may cause the pump 132 to circulate the working fluid at a rate proportionately to the intensity of solar irradiation received by the photovoltaic panel 132. In other words, when solar irradiation is intense, the recirculating pump 130 will circulate the working fluid at high rates through the various components of the solar thermal energy capture system 100. When
20 solar irradiation is modest or absent, e.g., through evening and into night conditions, the power generated by the photovoltaic panel 132 will diminish and cease thereby resulting in the cessation of working fluid flow throughout the solar thermal energy capture system 100. This increases the efficiency of the system and removes the system's reliance on grid-supplied electrical energy. It is optional to include an expansion tank 150 to accommodate
25 increases in the volume of working fluid circulating throughout the solar thermal energy capture system 100 as the temperature of the working fluid increases as a consequence of increasing solar irradiation intensity. It is also optional to incorporate a pressure relief valve 148 for emergency release of working fluid from the piping infrastructures comprising the solar thermal energy capture system 100 in the event of failures in one or more of the second
30 thermostatically actuated valve 145, and the recirculating pump 130, or if vapor locks occur unexpectedly within the piping infrastructure or any of the components comprising the solar thermal energy capture system 100.

- 14 -

The solar thermal energy capture systems of the present invention illustrated in Fig. 2 may be optionally fitted with and interconnected with a heat dissipater 140 as exemplified in Fig. 3. The solar energy collector panel 110 interconnected with the working fluid piping infrastructure 112 interconnected with the ingress inlet of the first thermostatically actuated valve 115 may be additionally interconnected with the ingress inlet of a second thermostatically actuated valve 145. The second ingress inlet of the second thermostatically actuated valve 145 is interconnected with the outlet of a heat dissipater 140 by piping 142. The inlet of the heat dissipater 140 is interconnected with piping 141 in fluid communication with the ingress inlet of the solar energy collector panel 110. When the temperature of the working fluid egressing from the solar energy collector panels 110 is about or greater than the maximum operating temperature preset on the second thermostatically actuated valve 145, the valve 145 will blend some of the working fluid egressing from the heat dissipater 140 through piping 142 for cooling therein to the maximum operating temperature after which the working fluid is conveyed through the egressing piping 112 interconnected with the first thermostatically actuated valve 115. The second thermostatically actuated valve 145 is responsive to temperature, pressure or other condition suitable as being indicative of overheating while the solar thermal energy capture system is in operation. Alternatively, the second thermostatically actuated valve 145 may be thermally-actuated, pressure-actuated, or activated by any other condition capable of being indicative of overheating. When the second thermostatically actuated valve 145 is thermally-actuated and the temperature of the working fluid exiting the one or more solar energy collector panels 110 reaches or exceeds the preset maximum temperature threshold, the second thermostatically actuated valve 145 will open and blend at least a portion of the working fluid from the heat dissipater 145 wherein the heated working fluid is cooled. The cooled working fluid egressing from the heat dissipater 140 is thereafter mixed with heated working fluid egressing from the solar energy collector panels 110 into the egressing piping infrastructure 112. When the temperature of the working fluid is below the preset maximum operating temperature, such as when sufficient heat has been used at the point of use or sufficient heat has been dissipated from the working fluid, the second thermostatically actuated valve 145 closes to divert the entire flow of working fluid toward the first thermostatically actuated valve 115. As the temperature of the heated working fluid fluctuates in response to changes in heat dissipation, such as when atmospheric conditions change and alter heat dissipation from the heat dissipater 140, the volume of working fluid mixed by the second thermostatically actuated valve 145 is continually

- 15 -

modulated to maintain the temperature of the working fluid at just under about the maximum preset operating temperature.

The heat dissipater 140 may comprise a fin and tube radiator for exchanging heat from the working fluid to the atmosphere. Alternatively, the heat dissipater 140 may
5 comprise a flat plate radiator, a ground loop or any other type of heat sink or dissipater to absorb the excess heat from the working fluid. One of skill in the art would appreciate that the size of the heat dissipater 140 would be sized in accordance with the size of the solar energy collector panels 110 and the demands of the particular solar thermal energy capture system 100 to balance the heat loss of the system with the heat gain.

10 Fig. 4 shows the heat exchange unit 150 separated from the hot water storage tank 121. Working fluid diverted into piping 116 by the first thermostatically actuated valve 115 flows through the heat exchange unit 150 and then is returned to piping infrastructure 125 for recycling back to the solar energy collector panel 110. Water is transferred from the hot water tank 121 to the heat exchange unit 150 by pump 151 wherein it acquires heat transferred
15 from the working fluid, and then is returned to the hot water storage tank 121 via piping 152.

It is within the scope of the present invention to provide strategically located fill valves and drain valves through out the solar thermal energy capture system 100 where appropriate to enable loading of the piping infrastructures 112 and/or 125 with working fluid, to allow periodic checking of the pH and compositional stability and quality of the working
20 fluid, and if necessary, to replace the working fluid with fresh working fluid, or alternatively, to add additional anti-scaling agents and/or anti-fouling and/or anti-corrosion agents and/or anti-freeze agents. It is optional if so desired, to use an oil as the working fluid. A suitable oil is exemplified by Duratherm LT heat transfer fluid (Duratherm Extended Life Fluids, Lewston, NY, USA).

25 According to one aspect of the present invention, the solar thermal energy capture system of the present invention may be a direct system or alternatively, an indirect system wherein the heating load fluid storage tank or reservoir 121 is in fluid communication with: (a) the first thermostatically actuated valve 115, and (b) point of use located throughout and/or connected to the building. Suitable points of use are exemplified by hot water storage
30 tanks, swimming pools, space heating via hydronics, forced-air heating systems, radiant or other fluid-based heating systems, process water treatment, working fluid heating for use in

- 16 -

industrial, refining, processing, power generation, smelting or commercial operations, heating of cleaning water for commercial laundries, car washes and the like, heating for oil, gas or water well heads, pipelines and livestock watering, or any other heating or pre-heating application, either directly or indirectly from the solar heated fluid. A suitable minimum
5 operating temperature for domestic water heating applications may be selected anywhere from the range of about 10° C to about 35°C, 15° C to about 25°C, about 20° C to about 25°C . If the end-point use is for heating a hot tub, then a suitable minimum operating temperature for domestic water heating applications may be selected anywhere from the range of about 15° C to about 50°C, about 25° C to about 45°C, about 35° C to about 45°C. If the end-point
10 use is for heating a space heater, then a suitable minimum operating temperature for domestic water heating applications may be selected anywhere from the range of about 10° C to about 65°C, about 20° C to about 55°C, about 25° C to about 50°C.

The present invention will be further illustrated in the following examples. However it is to be understood that these examples are for illustrative purposes only, and should not be
15 used to limit the scope of the present invention in any manner.

Example 1

A prototype solar thermal energy capture system was tested at an outdoor research facility in Calgary, AB, CA, in December 2010. The solar thermal energy capture system approximated the design shown in Fig. 2 and comprised three solar energy collector panels
20 mounted on the wall of a research building, each at an angle of about 85 degrees from horizontal. Each solar energy collector panel comprised twenty evacuated-tube collectors. The dimensions of each tube were 58mm × 1800mm, with each panel rated at a maximum thermal output of about 5,000 BTU per hour. The tops of the twenty tubes were interconnected with a top manifold (exemplified by products available from Jiangsu Sunrain
25 Co. Ltd.). The top manifolds of the three solar panels were interconnected and were in fluid communication with the ingress piping infrastructure. “Ingress inlet” temperatures were recorded about the interconnection of the ingress piping infrastructure with the array of solar panels. “Egress outlet” temperatures were recorded about the interconnection of the egress piping infrastructure with the array of solar panels. The egress and ingress piping
30 infrastructures were constructed with ¾” cross-linked polyethylene (PEX) pipe and fittings. The working fluid comprised about 40% distilled water mixed and about 60% non-toxic

- 17 -

propylene glycol to ensure the working fluid did not freeze at -40° C temperatures. An expansion tank having a volume sufficient to contain about 5% of the volume of the fluid at 20° C, was fluidly connected to the ingress piping infrastructure. The pressure within the piping infrastructure was maintained at a lower pressure (~20 psi) than that in the hot water tank (~70 psi) to avoid propylene glycol from entering the domestic hot water system in the event of a leak in the internal heat exchanger in the storage tank. A 16-foot length of fin and tube radiator formed the heat dissipater for the solar thermal energy capture system and was fluidly connected to the piping infrastructure to allow at least a portion of the working fluid to bypass the solar energy collector panels. The heat dissipater was sized to exceed the maximum BTU rating of the solar energy array by about 16% or about 2,400 BTU per hour. An inlet to the heat dissipater was upstream of the solar energy collector panels and an outlet of the heat dissipater was downstream of the solar energy collector. A thermally-actuated M/D temperature control valve, exemplified by those available from Therm-Omega-Tech Inc. (e.g., Model 353-000-200, Therm-Omega-Tech Inc, Warminster, PA, USA), was connected to the piping infrastructure downstream from the solar energy collector panels and the heat dissipater. The preset maximum operating temperature of the control valve was set at 90° C (200° F). The control valve was installed to mix the flow of at least a portion of the working fluid from the heat dissipater with the fluid from the solar energy collector panels if the temperature of the working fluid exceeded 90° C. A second thermally actuated M/D control valve designed for 3-way diverting of fluid flows (e.g., Model 353-000-070, Therm-Omega-Tech, Warminster, PA, USA) was interposed the egress piping infrastructure downstream to the solar thermal energy capture panels and upstream to the solar hot water tank. This diverting valve diverts working fluid with a temperature: (a) less than about 20° C (70° F) back to the solar collector panels, and (b) greater than about 20° C (70° F) into the heat exchanger inside the solar hot water tank. A variable-speed DC Pump, exemplified by an Ecocirc[®] pump (Ecocirc is a registered trademark of Laing Thermotech, Inc., San Diego, CA, USA) was used to pump the working fluid through the egress piping and ingress piping infrastructure. The DC pump was powered by a 25 watt photovoltaic solar panel (available from Fuzhou Pingchi Import & Trading Co of China) located on one of the solar collector panels. Fill and drain valves were incorporated into the piping infrastructure to facilitate loading of the piping infrastructure and to permit periodic checking of the pH and strength of the propylene glycol/water mixture. A pressure relief valve ("PRV") with a preset pressure threshold of about 50 psi was connected to the piping infrastructure. The PRV was configured to open and release the working fluid to the roof of the structure if the pressure

- 18 -

within the piping infrastructure exceeded the preset pressure threshold, for example as a result of a failure in the system. An anti-scald valve (Danfoss ESSBE 065B8870 valve available from Danfoss Hydronic Heating North America) was placed on the outlet of the solar hot water tank to act as a safety device for ensuring water exiting the solar hot water tank did not exceed a safe temperature, in this case about 55° C (131° F) to about 60° C (140° F). The egress piping infrastructure was interconnected with a 300-L solar hot water tank located in the building's heated mechanical room. The egress piping infrastructure was about 20 metres long, with 10 metres fastened to the building's exterior surfaces and the remainder connecting the exterior portion of the piping infrastructure with the solar hot water tank. A digital flow meter measured the rate of flow of the working fluid circulated by the DC pump. The solar thermal energy capture system was provided with temperature sensors mounted on the piping infrastructure in a number of locations, including: (a) about the ingress inlet to the solar thermal array consisting of three solar energy collector panels; (b) about the egress outlet from the solar thermal array; and (c) about the inlet to the solar hot water storage tank.

Fig. 5 shows the temperature changes that occurred over a 2-h period between 9 am and 11 am. The ambient temperature at 9 am was about -12° C. It was a sunny day with no cloud cover. During the time period between 9 am and 9:23 am, there was no flow of working fluid from the solar-powered DC pump (solid black line). Temperatures about the inlet and about the outlet of three array of solar energy collector panels were about -11° C (grey squares and black diamond, respectively). The temperature about the inlet to the hot water tank was about 15° C (light grey triangles) which represented the ambient temperature near the floor of the heated mechanical room.

The DC pump started up at about 9:23 am, as evidenced by detection of flow of the working fluid. The working fluid continued to flow, albeit at different rates, for the duration of the start-up time. As soon as the pump started, the temperature about the inlet to the array of solar energy collector panels spiked from 11° C to about 15° C, as a consequence of transfer of working fluid that was resident in the ingress piping infrastructure located inside the heated building to the array. The temperature about the egress outlet from the array of solar energy collector panels also increased but lagged about 10 minutes behind the increase in fluid temperatures at the array ingress inlet. This lag represents the amount of time that was required to clear the "over-night" working fluid from the array of solar energy collector panels. The temperature at the ingress inlet adjacent to the solar hot water storage tank inlet

- 19 -

dropped about 5° C as the colder outside fluid was transferred through the egress piping infrastructure to about the inlet to the solar hot water storage tank. Because the temperature of the “over-night” working fluid displaced from array of solar energy collector panels was below 20° C, the thermostatic diverting valve directed the flow of the “over-night” working fluid back to the solar energy collector panels resulting in a drop in the temperatures measured at about the ingress inlet to the array of solar energy collector panels.

At about 9:40 am the temperature at the inlet to the solar array stopped dropping as the cold outside fluid and the warm inside fluid blended and reflects a mixed temperature of - 3° C. At this point the working fluid started to increase as a result of the solar energy gain.

At about 9:50 am, the solar thermal energy capture system stabilized and the temperatures at about both the ingress inlet and the egress outlet of the array of solar energy collector panels began climbing as the system settled into a heating mode.

At approximately 10:21 am, the temperature recordings about the egress outlet of the solar panels exceeded 20° C and the thermostatic valve began diverting the solar-irradiation-warmed working fluid egressing from the solar energy collector panels to the heat exchanger in the solar hot water storage tank. This resulted in the ingress inlet to the solar hot water storage tank beginning to increase (light grey triangles) as well as cooling of the working fluid as evidenced by the drop in ingress temperature to the solar array (boxes) after a few minutes delay.

By 10:30 am, the solar thermal energy capture system settled into its heat production mode. The pump recirculated the working fluid at a steady rate of about 1.7 liters pr minute. The temperatures about the ingress inlet to the array of solar energy collector panels stabilized at about 15° C (dark grey squares), reflecting the cold domestic water temperature in the solar hot water storage tank that started to gradually increase. The temperatures about the egress outlet of the array stabilized near 35° C (black diamonds) and were similar to the temperatures recorded about the inlet to the heat exchanger on the solar hot water storage tank (light grey triangles) which is slightly lower due to ambient losses in the piping infrastructure.

Example 2

- 20 -

The prototype system described in Example 1 was configured and installed on a research building in Calgary, AB, CA, in August 2010. Fig. 6 shows the temperature changes that occurred over a 2-h period between 10 am and 12 noon. The ambient temperature at 10 am was about +12° C.

5 The pump commenced operation at about 10:25 am and within 5 minutes, the temperatures recorded at the inlet and outlet of the solar collector panels reversed. The temperatures recorded at the egress outlet of the solar collector panels spiked as the working fluid heated by solar irradiation of the solar panels prior to commencement of the flow of working fluid flowed into the egress piping infrastructure. Concurrently the inlet temperature
10 of the solar collector panels dropped as the working fluid that was heated by solar irradiation prior to the commencement of the flow of working fluid, was replaced by the ambient (i.e., +12° C) working fluid that sat in the ingress piping infrastructure. The temperatures recorded about the inlet to the solar hot water storage tank were stable until about 10:30 AM at which point the spike in the solar outlet temperature is mirrored with about an 8 minute time delay.
15 The working fluid and piping infrastructure continue to warm up until about 10:35, at which time the thermostatically actuated valve began diverting the flow of working fluid from the ingress piping into the heat exchanger inside the hot water storage tank as evidenced by the increase in the temperature at the inlet to the solar hot water storage tank and the drop in the solar inlet temperature. By 10:40 am, the system entered the heating production mode.

20 In comparison to the temperature recordings from the December trial outlined in Example 1, the August system start-up process diverted the flow of cold working fluid from the hot water storage tank for only about 10 minutes, whereas the December start-up process diverted cold working fluid from the hot water storage tank for over one hour.

CLAIMS:

1. A thermoregulation apparatus for a solar thermal energy capture system, wherein the solar thermal energy capture system comprises a piping infrastructure in fluid communication with a fluid storage tank and one or more solar thermal energy collectors, the thermoregulation apparatus comprising:

a thermostatically actuated valve interposed the piping infrastructure downstream from the one or more solar energy collectors and upstream from the fluid storage tank; and

piping for interconnecting the thermostatically actuated valve with the piping infrastructure, and the fluid storage tank;

wherein the thermostatically actuated valve (i) diverts the flow of a working fluid away from the fluid storage tank when the temperature of the working fluid is below a selected set point for actuating the valve, and (ii) diverts the flow of working fluid to the fluid storage tank when the temperature of the working fluid is about or greater than the selected set point.

2. The thermoregulation apparatus of claim 1, wherein thermoregulation apparatus is interposed the piping infrastructure downstream from the one or more solar energy collectors and upstream from a heat exchange unit communicating with the fluid storage tank, wherein one side of the heat exchange unit is communicable with the thermostatically actuated valve and the other side of the heat exchange unit is communicable with the fluid storage tank.

3. The thermoregulation apparatus of claim 1, wherein the working fluid comprises one of water or oil.

4. The thermoregulation apparatus of claim 1, wherein the working fluid comprises water and an additive selected from the group consisting of anti-scaling agents, anti-fouling agents, anti-corrosion agents, and anti-freeze agents.

5. The thermoregulation apparatus of claim 1, wherein the set point for actuating the valve of the thermostatically activated valve is selected from the range of about 10° C to about 65° C.

6. The thermoregulation apparatus of claim 1, wherein the set point for actuating the valve of the thermostatically activated valve is selected from the range of about 15° C to about 55° C.

7. A thermoregulation kit for installation into a solar thermal energy capture system, wherein the solar thermal energy capture system comprises a piping infrastructure in fluid communication with a fluid storage tank and one or more solar thermal energy collectors, the thermoregulation apparatus comprising:

a thermostatically actuated valve for installation interposed the piping infrastructure downstream from the one or more solar energy collectors and upstream from the fluid storage tank; and

piping for interconnecting the thermostatically actuated valve with the piping infrastructure, and the fluid storage tank;

wherein the thermostatically actuated valve (i) flow of working fluid away from the fluid storage tank when the temperature of the working fluid is below a selected set point, and (ii) diverts the flow of working fluid to the fluid storage tank when the temperature of the working fluid is about or greater than the selected set point.

8. A thermoregulation kit for installation into a solar thermal energy capture system, the kit comprising:

the thermostatically actuated valve according to claim 2; and

piping for interconnecting the thermostatically actuated valve with (i) the piping infrastructure, and (ii) the fluid storage tank, and/or (iii) the heat exchange unit.

9. A solar thermal energy capture system provided with a thermoregulation apparatus, the solar thermal energy capture system comprising:

one or more solar thermal energy collectors;

a fluid storage tank;

a piping infrastructure fluidly interconnected with the one or more solar thermal energy collectors and the piping infrastructure;

a working fluid communicating with the one or more solar thermal energy collectors and the piping infrastructure;

a thermostatically actuated valve positionable interposed the piping infrastructure downstream from the one or more solar energy collectors and upstream from the fluid storage tank;

piping for interconnecting the thermostatically actuated valve with the piping infrastructure and the fluid storage tank; and

a pump for circulating the working fluid throughout the solar thermal energy capture system;

wherein the thermostatically actuated valve (i) the flow of working fluid away from the fluid storage tank when the temperature of the working fluid is below a selected set point for actuating the valve, and (ii) diverts the flow of working fluid to the fluid storage tank when the temperature of the working fluid is about or greater than the selected set point.

10. The solar thermal energy capture system of claim 9, wherein the set point for actuating the valve of the thermostatically activated valve is selected from the range of about 10° C to about 65° C.

11. The solar thermal energy capture system of claim 9, wherein the set point for actuating the valve of the thermostatically activated valve is selected from the range of about 15° C to about 55° C.

12. The solar thermal energy capture system of claim 9, wherein the working fluid comprises one of oil, water, and a mixture of water and one of an anti-scaling agent, an anti-fouling agent, and an anti-freeze agent.

13. The solar thermal energy capture system of claim 9, additionally provided with a heat exchange unit interposed the thermostatically actuated valve and the fluid storage tank wherein one side of the heat exchange unit is fluidly communicable with the thermostatically actuated valve and the other side of the heat exchange unit is communicable with the fluid storage tank.

14. The solar thermal energy capture system of claim 9, additionally provided with a heat dissipater in controllable fluid communication the piping infrastructure egressing from the one or more solar thermal energy collectors.

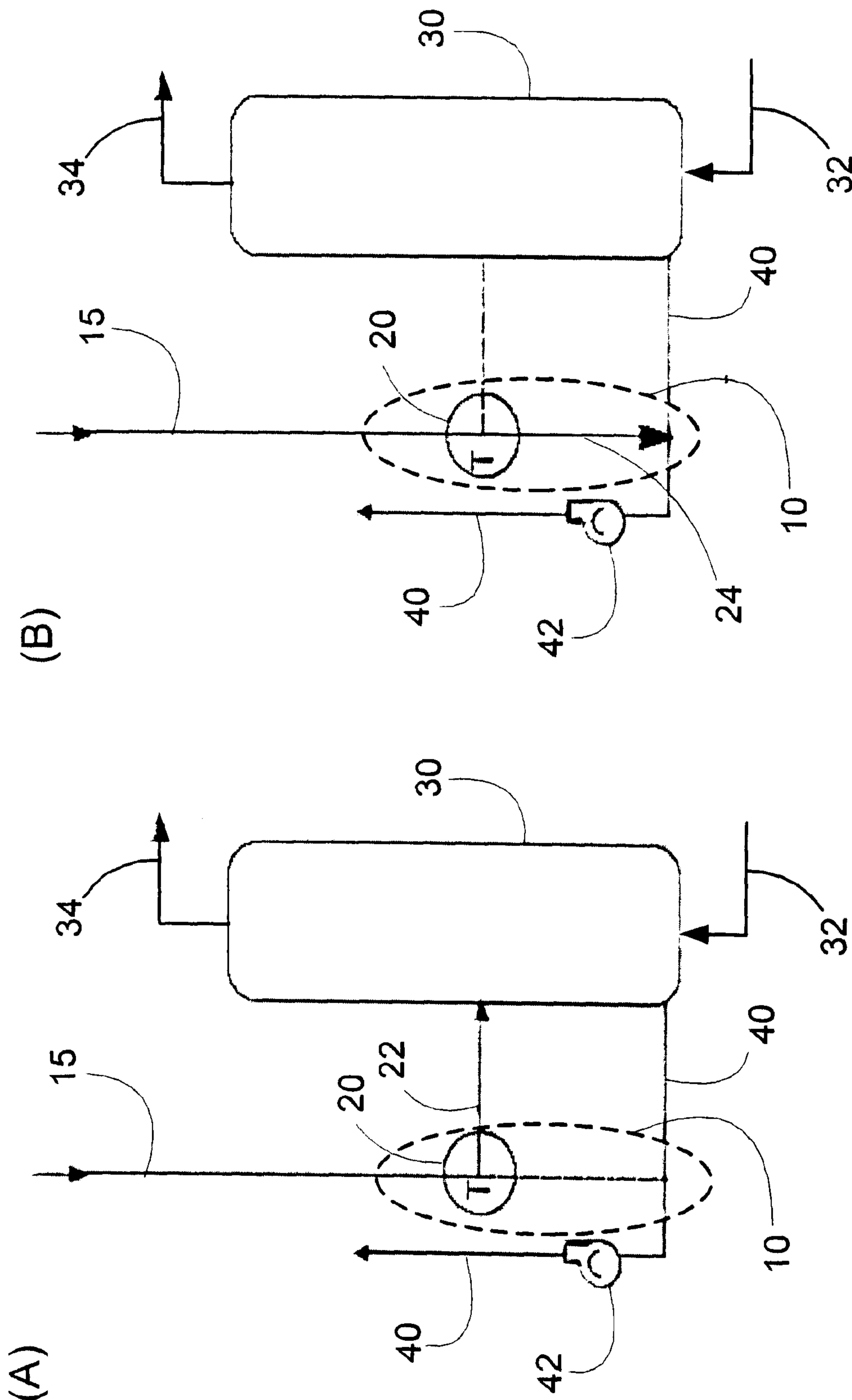

Fig. 1

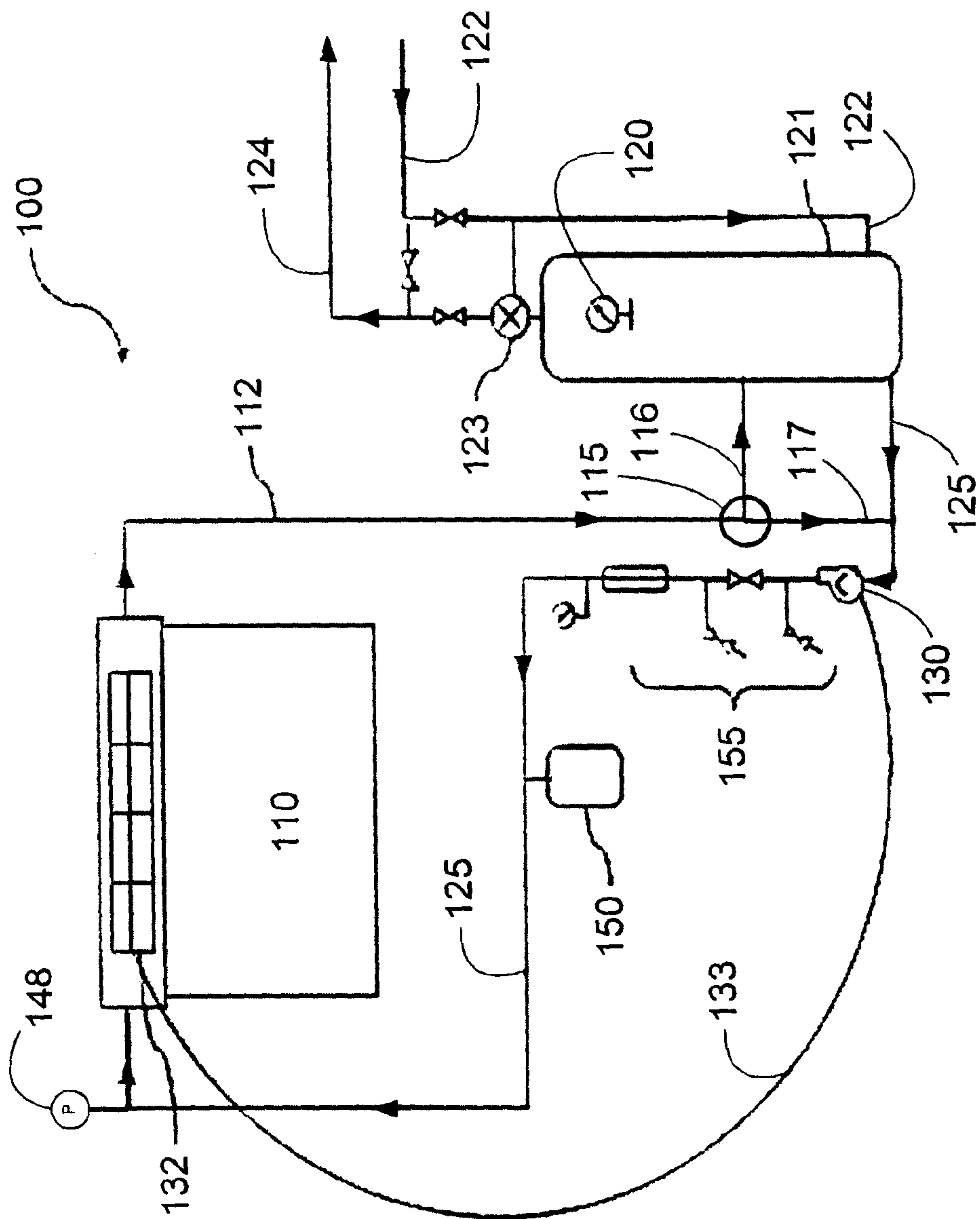

Fig. 2

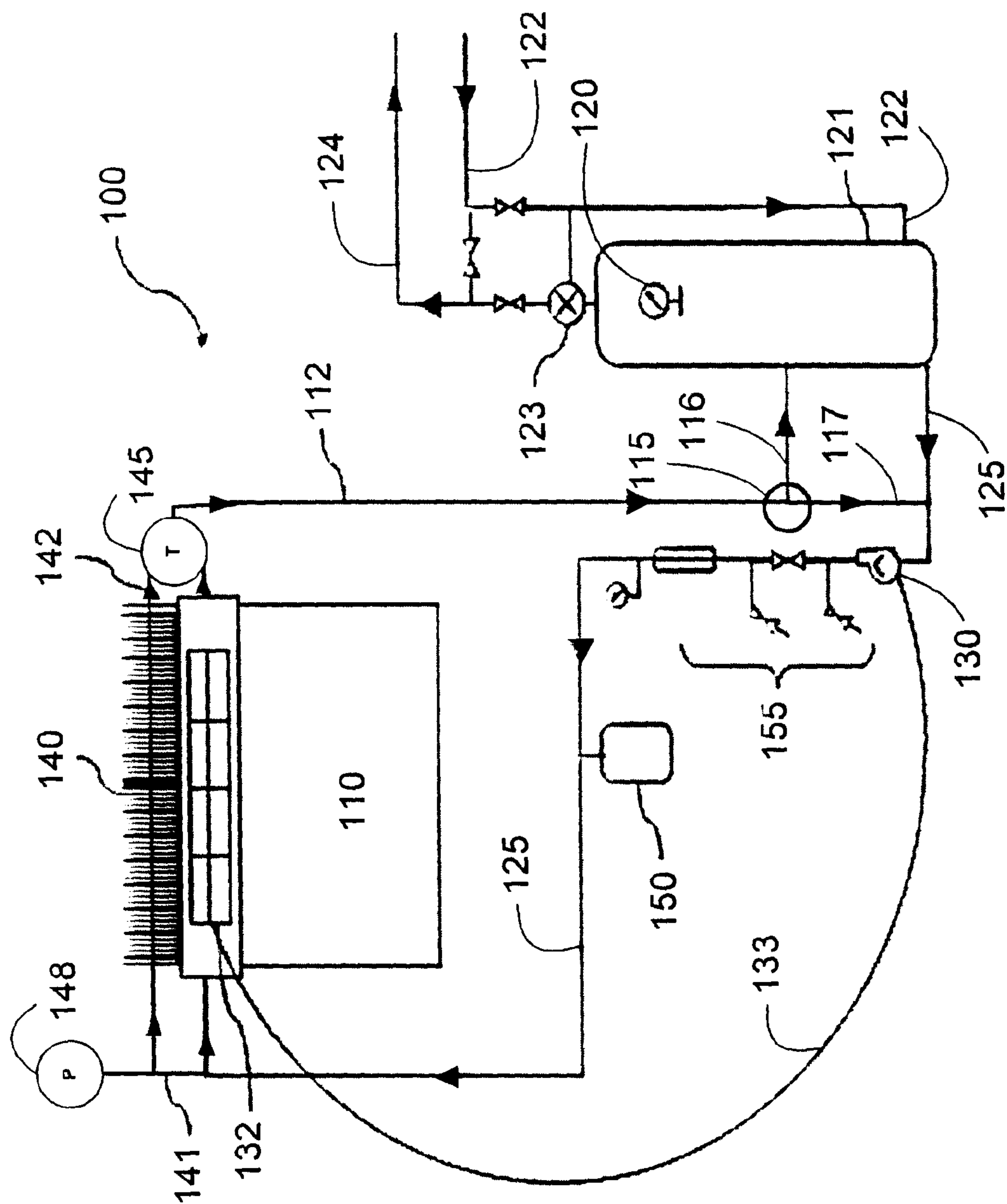

Fig. 3

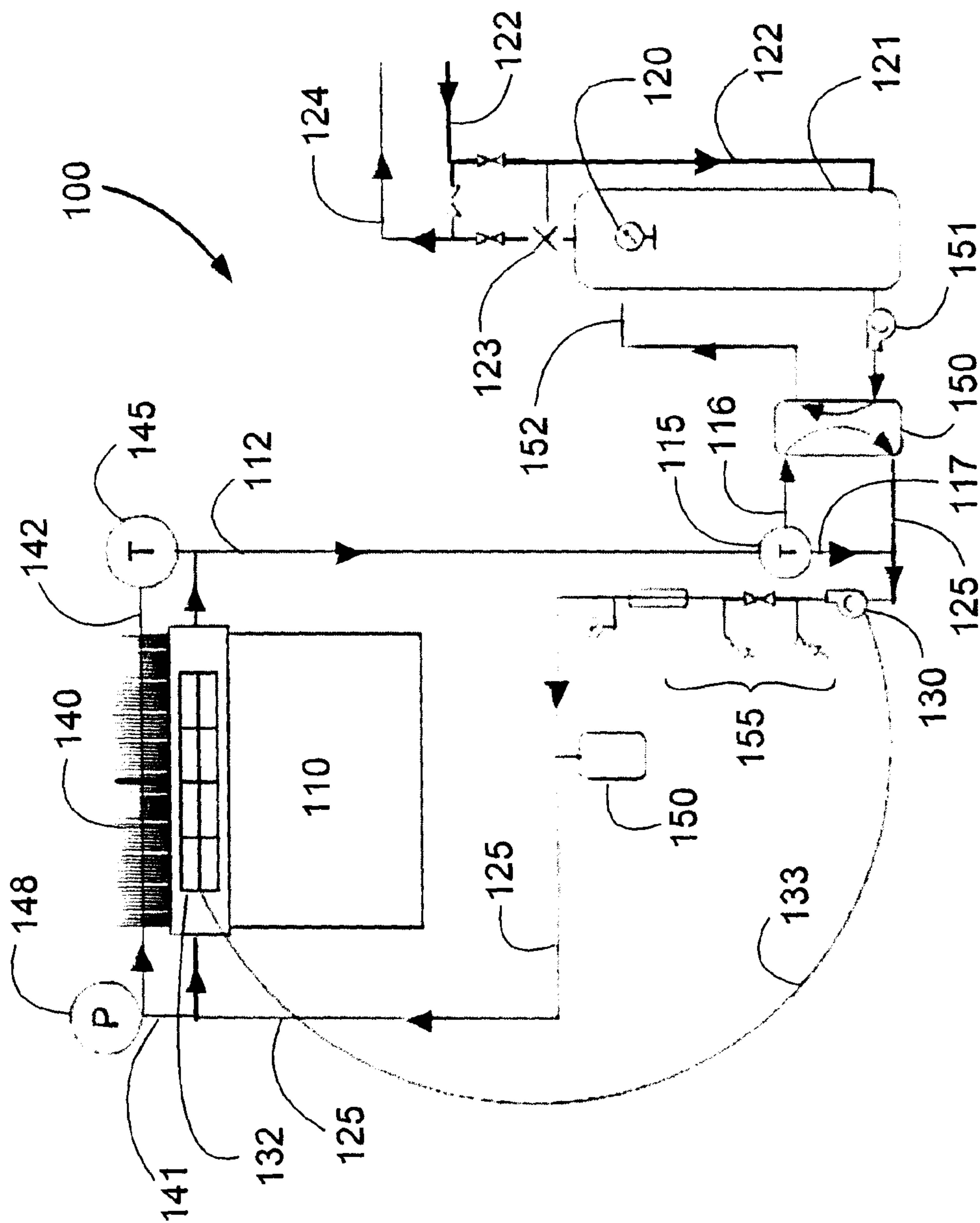

Fig. 4

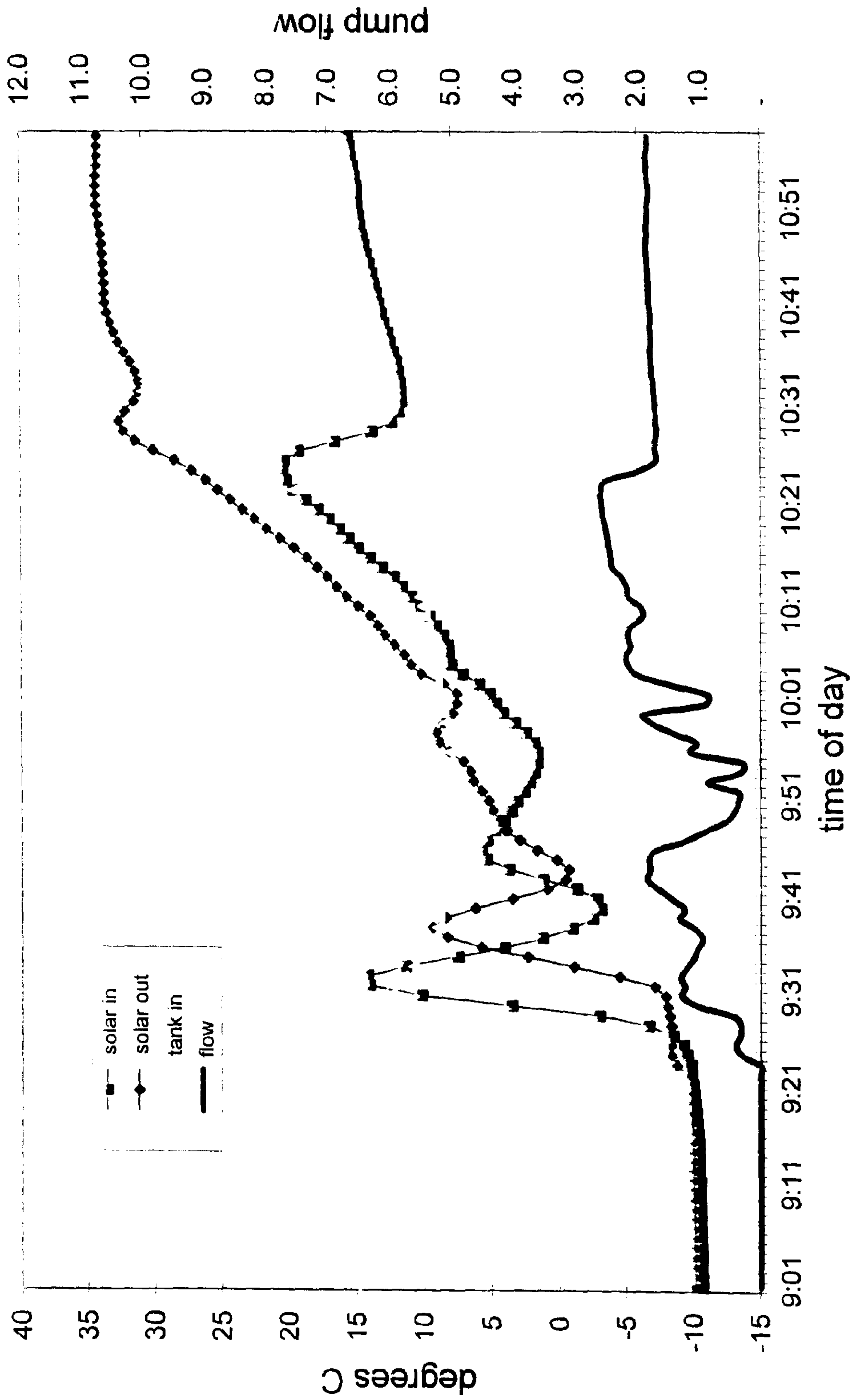

Fig. 5

6/6

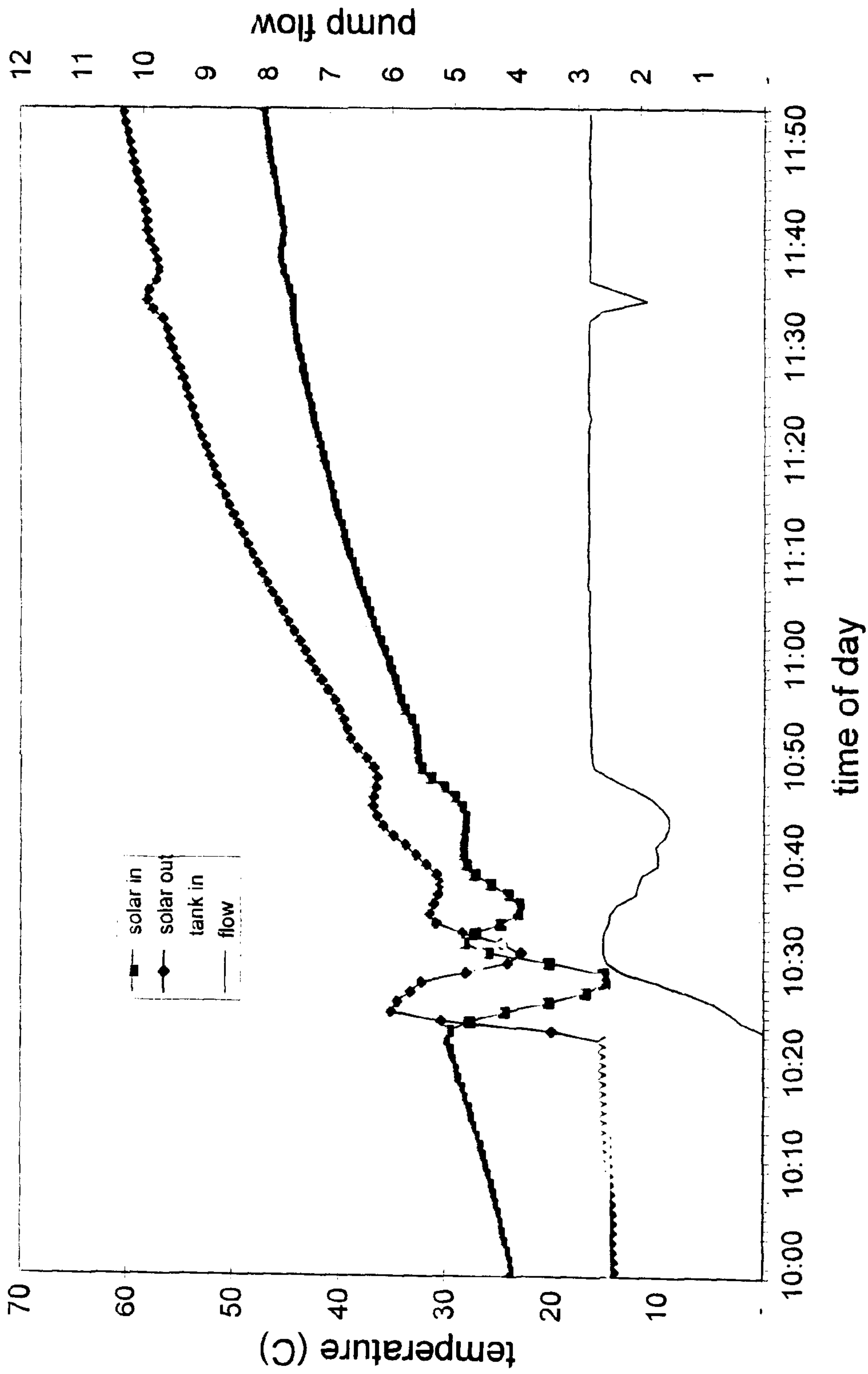
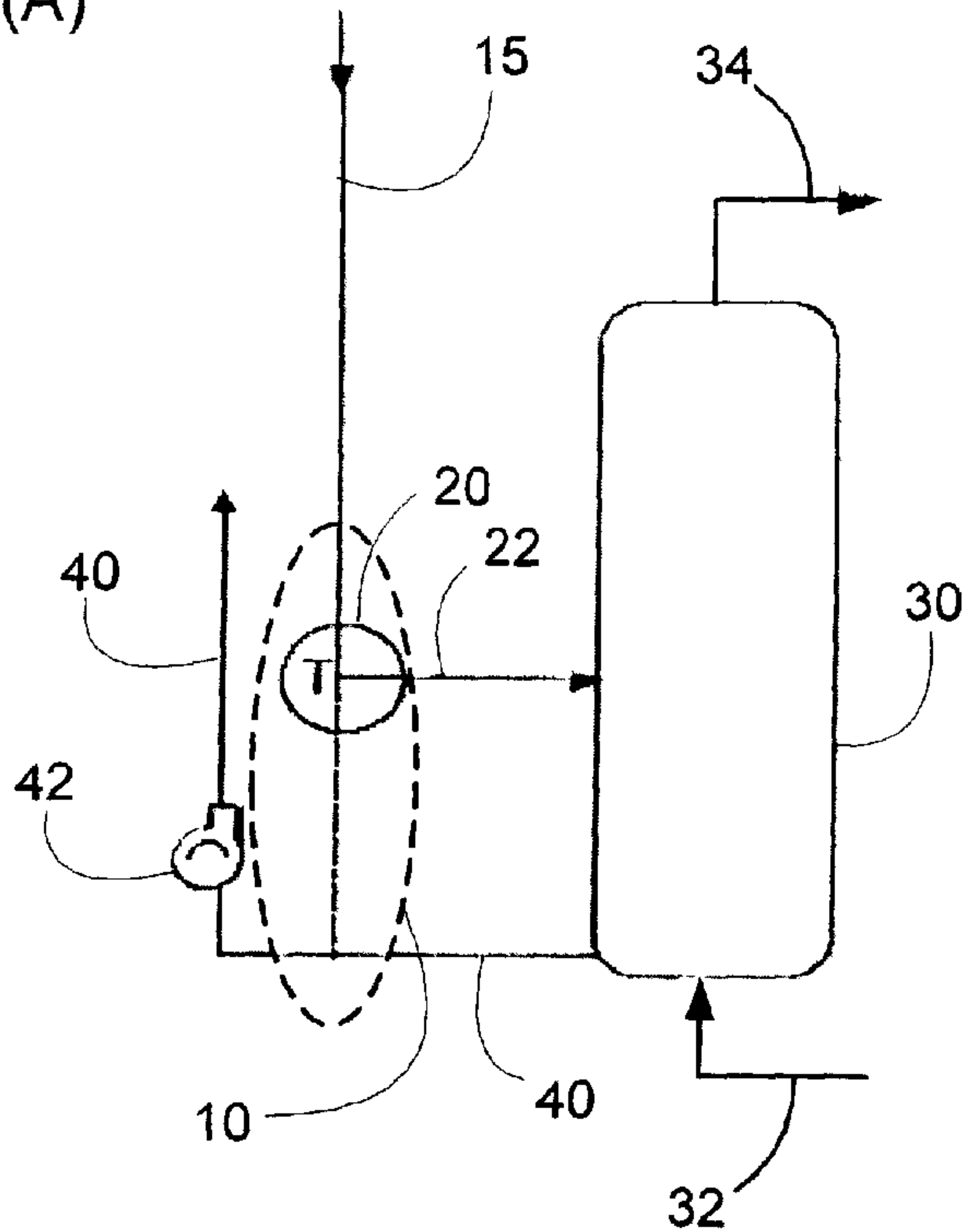

Fig. 6

(A)



(B)

