



- (51) International Patent Classification:
A61F 2/06 (2013.01) A61F 2/07 (2013.01)
- (21) International Application Number:
PCT/IL2017/051092
- (22) International Filing Date:
28 September 2017 (28.09.2017)
- (25) Filing Language: English
- (26) Publication Language: English
- (30) Priority Data:
62/401,403 29 September 2016 (29.09.2016) US
- (71) Applicant: MAGENTA MEDICAL LTD. [IL/IL];
Haofeh 1, 60920 Kadima (IL).
- (72) Inventors: TUVAL, Yosi; Hashalom 8, 40500 Even
Yehuda (IL). SCHWAMMENTHAL, Ehud; Haavoda 5a,
43411 Raanana (IL). GLOZMAN, Daniel; 37 Odem Street,
4034723 Kfar Yona (IL). LUBINSKY, Gad; 1 Tze'elon
Street, 4069600 Ein Vered (IL).
- (74) Agent: COLB, Sanford T. et al.; SANFORD T. COLB &
CO., 4 Shaar Hagai Street, P.O. Box 2273, 7612201 Re-
hovot (IL).
- (81) Designated States (unless otherwise indicated, for every
kind of national protection available): AE, AG, AL, AM,
AO, AT, AU, AZ, BA, BB, BG, BH, BN, BR, BW, BY, BZ,

CA, CH, CL, CN, CO, CR, CU, CZ, DE, DJ, DK, DM, DO,
DZ, EC, EE, EG, ES, FI, GB, GD, GE, GH, GM, GT, HN,
HR, HU, ID, IL, IN, IR, IS, JO, JP, KE, KG, KH, KN, KP,
KR, KW, KZ, LA, LC, LK, LR, LS, LU, LY, MA, MD, ME,
MG, MK, MN, MW, MX, MY, MZ, NA, NG, NI, NO, NZ,
OM, PA, PE, PG, PH, PL, PT, QA, RO, RS, RU, RW, SA,
SC, SD, SE, SG, SK, SL, SM, ST, SV, SY, TH, TJ, TM, TN,
TR, TT, TZ, UA, UG, US, UZ, VC, VN, ZA, ZM, ZW.

- (84) Designated States (unless otherwise indicated, for every
kind of regional protection available): ARIPO (BW, GH,
GM, KE, LR, LS, MW, MZ, NA, RW, SD, SL, ST, SZ, TZ,
UG, ZM, ZW), Eurasian (AM, AZ, BY, KG, KZ, RU, TJ,
TM), European (AL, AT, BE, BG, CH, CY, CZ, DE, DK,
EE, ES, FI, FR, GB, GR, HR, HU, IE, IS, IT, LT, LU, LV,
MC, MK, MT, NL, NO, PL, PT, RO, RS, SE, SI, SK, SM,
TR), OAPI (BF, BJ, CF, CG, CI, CM, GA, GN, GQ, GW,
KM, ML, MR, NE, SN, TD, TG).

Published:

— with international search report (Art. 21(3))

(54) Title: BLOOD VESSEL TUBE

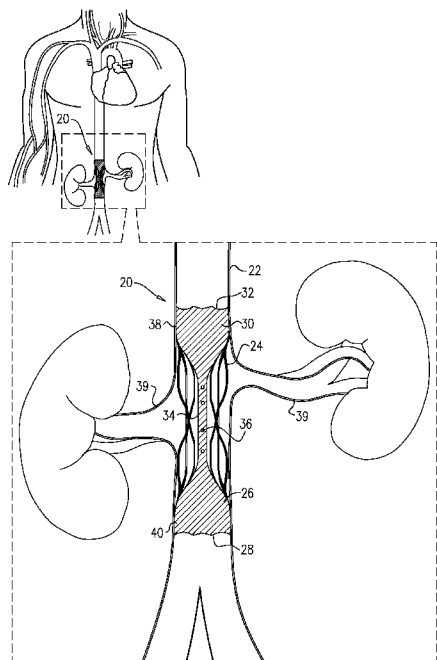

FIG. 1

(57) Abstract: Apparatus and methods are described including a tube (20) that defines a flared downstream portion (30) that diverges toward a downstream end (32) of the tube, and a flared upstream portion (26) that diverges toward an upstream end (28) of the tube, such that a central portion (34) of the tube is narrower than at the ends of the tube. The tube defines a plurality of lateral openings (36). A support frame (24) supports the tube within a subject's vena cava, such that the downstream portion is sealed with respect to the wall of the vena cava downstream of junctions of the vena cava with all of the subject's renal veins, and the upstream portion is sealed with respect to the inner wall of the vena cava upstream of junctions of the vena cava with all of the subject's renal veins. Other applications are also described.

WO 2018/061002 A1

BLOOD VESSEL TUBE

CROSS-REFERENCE TO RELATED APPLICATION

The present application claims priority from US Provisional Patent Application 62/401,403 to Tuval, filed Sep. 29, 2016, entitled "Blood vessel tube," which is incorporated
5 herein by reference.

FIELD OF EMBODIMENTS OF THE INVENTION

Some applications of the present invention generally relate to medical apparatus. Specifically, some applications of the present invention relate to apparatus and methods associated with placing a passive medical device in a subject's vena cava.

10

BACKGROUND

It is common for cardiac dysfunction or congestive heart failure to develop into kidney dysfunction, which, in turn, causes congestive heart failure symptoms to develop or worsen. Typically, systolic and/or diastolic cardiac dysfunction causes systemic venous congestion, which gives rise to an increase in renal venous and interstitial pressure. The increase in the
15 pressure causes fluid retention by the body to increase due both to kidney dysfunction and renal neurohormonal activation, both of which typically develop as a result of the increase in renal venous and interstitial pressure. The resulting fluid retention causes congestive heart failure to develop or worsen, by causing a blood volume overload at the heart and/or by increasing systemic resistance. Similarly, it is common for kidney dysfunction and/or renal
20 neurohormonal activation to develop into cardiac dysfunction and/or congestive heart failure. This pathophysiological cycle, in which cardiac dysfunction and/or congestive heart failure leads to kidney dysfunction and/or renal neurohormonal activation, or in which kidney dysfunction and/or renal neurohormonal activation leads to cardiac dysfunction and/or congestive heart failure, each dysfunction leading to deterioration in the other dysfunction, is
25 called the cardio-renal syndrome.

Increased renal venous pressure has been experimentally shown to cause azotemia, and a reduction in glomerular filtration rate, renal blood flow, urine output, and sodium excretion. It has also been shown to increase plasma renin and aldosterone, and protein excretion. Venous congestion may also contribute to anemia via three different pathways: A

reduction in the kidney's erythropoietin production, hemodilution by fluid retention, and an inflammatory response leading to a reduced gastro-intestinal iron uptake.

Mechanistically, increased renal venous pressure may cause intracapsular pressure and, subsequently, interstitial peritubular pressure, to rise. A rise in peritubular pressure may impact tubular function (reduce sodium excretion), as well as diminish glomerular filtration, by raising the pressure in the Bowman capsule.

In heart failure patients, increased renal venous pressure may not only result from increased central venous (right atrial) pressure, but also from intraperitoneal fluid accumulations (ascites) exerting direct pressure on the renal veins. Reduction of intraabdominal pressure in heart failure patients by removal of fluid (e.g., via paracentesis, and/or ultrafiltration), has been shown to reduce plasma creatinine levels.

Increased venous return resulting from activation of the "leg muscle pump" during physical activity such as walking may raise systemic venous pressure, particularly in heart failure patients, and may result in reflux into the renal veins.

15

SUMMARY OF EMBODIMENTS

In accordance with some applications of the present invention, a subject is identified as suffering from cardiac dysfunction, congestive heart failure, reduced renal blood flow, increased renal vascular resistance, arterial hypertension, diabetes, and/or kidney dysfunction. In response thereto, a venturi tube is placed inside the subject's vena cava. The venturi tube (when disposed in a non-constrained configuration) defines a flared downstream portion that diverges toward a downstream end of the tube, and a flared upstream portion that diverges toward an upstream end of the tube, such that a central portion of the tube is narrower than at the ends of the tube. The tube defines one or more lateral openings along the central portion of the tube. The tube is placed within the subject's vena cava, such that the downstream portion of the tube is sealed with respect to the inner wall of the vena cava at a location that is downstream of junctions of the vena cava with all of the subject's renal veins, and the upstream portion of the tube is sealed with respect to the inner wall of the vena cava at a location that is upstream of junctions of the vena cava with all of the subject's renal veins.

The tube, when placed in the vena cava in the above-described manner, is configured to cause blood flow through the tube to undergo the venturi effect as it passes through the

tube. That is, the tube generates a region of low pressure between the ends of the tube, due to the blood flowing from the upstream end of the tube through the narrow central region of the tube. Pressure within the central region of the tube is lower than the pressure in the subject's renal veins in the absence of the tube. Therefore, blood from the subject's renal veins is drawn into the tube, via the lateral opening defined by the tube. In this manner, pressure within the subject's renal veins is reduced.

For some applications, a generally similar effect to that described above with reference to the placement of a venturi tube in the vena cava is achieved by placing a first nozzle in the subject's vena cava upstream of junctions of the vena cava with all of the subject's renal veins, such that the first nozzle converges in a direction of antegrade blood flow through the vena cava, and placing a second nozzle in the subject's vena cava downstream of the junctions of the vena cava with all of the subject's renal veins. Due the convergence of the first nozzle, blood flowing through the nozzle undergoes the venturi effect, thereby creating a region within the vena cava downstream of the nozzle that has a lower blood pressure than the blood pressure in the renal veins in the absence of the nozzle. Therefore, blood from the subject's renal veins is drawn into the region within the vena cava that is downstream of the nozzle. In this manner, pressure within the subject's renal veins is reduced.

For some applications, the second nozzle is placed in the subject's vena cava, such that the second nozzle converges in the direction of antegrade blood flow through the vena cava. The second nozzle is configured to impede backflow of blood toward the low-pressure region from regions within the vena cava that are downstream of the junctions of the vena cava with the subject's renal veins. Alternatively, the second nozzle is placed in the subject's vena cava, such that the second nozzle diverges in the direction of antegrade blood flow through the vena cava (i.e., the second nozzle converges in the direction of retrograde blood flow through the vena cava). The second nozzle is configured to impede backflow of blood toward the low-pressure region from regions within the vena cava that are downstream of the junctions of the vena cava with the subject's renal veins. Furthermore, the second nozzle is configured to cause any blood that does flow back, via the second nozzle toward the low-pressure region, to undergo the venturi effect by virtue of having flowed through the nozzle. Therefore, backflowing blood that passes through the nozzle is caused to be at low pressure once it passes through the nozzle.

In general, in the specification and in the claims of the present application, the term "downstream" and related terms, when used with reference to a blood vessel, or with reference to a portion of a device that is configured to be placed inside a blood vessel, should be interpreted to mean a location within the blood vessel, or a portion of the device that is intended for placement at a location within the blood vessel, that is downstream, with respect to the direction of antegrade blood flow through the blood vessel, relative to a different location within the blood vessel. The term "upstream" and related terms, when used with reference to a blood vessel, or with reference to a portion of a device that is configured to be placed inside a blood vessel, should be interpreted to mean a location within the blood vessel, or a portion of the device that is intended for placement at a location within the blood vessel, that is upstream with respect to the direction of antegrade blood flow through the blood vessel, relative to a different location within the blood vessel.

There is therefore provided, in accordance with some applications of the present invention, apparatus for use with renal veins and a vena cava of a subject, the apparatus including:

a tube that defines:

a flared downstream portion thereof that diverges toward a downstream end of the tube, and a flared upstream portion thereof that diverges toward an upstream end of the tube, such that a central portion of the tube is narrower than at the ends of the tube, and

a plurality of lateral openings; and

a support frame configured to support the tube within the subject's vena cava, such that:

the downstream portion of the tube is sealed with respect to an inner wall of the vena cava at a location that is downstream of junctions of the vena cava with all of the subject's renal veins, and

the upstream portion of the tube is sealed with respect to the inner wall of the vena cava at a location that is upstream of junctions of the vena cava with all of the subject's renal veins.

In some applications, the plurality of lateral openings are shaped such as to converge toward a longitudinal axis of the tube.

In some applications, an inner diameter of the tube at a location at which the inner diameter is at its maximum is greater than 12 mm.

In some applications, an inner diameter of the tube at a location at which the inner diameter is at its minimum is less than 8 mm.

5 In some applications, a ratio between an inner diameter of the tube at a location at which the inner diameter is at its maximum and an inner diameter of the tube at a location at which the inner diameter is at its minimum is greater than 3:1.

In some applications, a length of the tube is greater than 20 mm.

In some applications, the apparatus further includes:

10 one or more blood pressure sensors configured to measure blood pressure within the vena cava; and

a computer processor configured to modulate a diameter of the central portion of the tube responsively to the measured blood pressure.

15 In some applications, the one or more blood pressure sensors are configured to measure an indication of renal venous pressure of the subject.

In some applications, the one or more blood pressure sensors are configured to measure an indication of central venous pressure of the subject.

In some applications, the one or more blood pressure sensors are configured to measure an indication of lower-body venous pressure of the subject.

20 There is further provided, in accordance with some applications of the present invention, a method for use with renal veins and a vena cava of a subject, the method including:

providing a tube that defines:

25 a flared downstream portion thereof that diverges toward a downstream end of the tube, and a flared upstream portion thereof that diverges toward an upstream end of the tube, such that a central portion of the tube is narrower than at the ends of the tube, and

a plurality of lateral openings; and

placing the tube within the subject's vena cava, such that:

the downstream portion of the tube is sealed with respect to an inner wall of the vena cava at a location that is downstream of junctions of the vena cava with all of the subject's renal veins, and

5 the upstream portion of the tube is sealed with respect to the inner wall of the vena cava at a location that is upstream of junctions of the vena cava with all of the subject's renal veins.

In some applications, providing the tube includes providing the tube, the plurality of lateral openings being shaped such as to converge toward a longitudinal axis of the tube.

10 In some applications, providing the tube includes providing the tube, an inner diameter of the tube at a location at which the inner diameter is at its maximum being greater than 12 mm.

In some applications, providing the tube includes providing the tube, an inner diameter of the tube at a location at which the inner diameter is at its minimum being less than 8 mm.

15 In some applications, providing the tube includes providing the tube, a ratio between an inner diameter of the tube at a location at which the inner diameter is at its maximum and an inner diameter of the tube at a location at which the inner diameter is at its minimum being greater than 3:1.

20 In some applications, providing the tube includes providing the tube, a length of the tube being greater than 20 mm.

In some applications, the method further includes:
measuring blood pressure within the vena cava; and
modulating a diameter of the central portion of the tube responsively to the measured blood pressure.

25 In some applications, measuring blood pressure within the vena cava includes measuring an indication of renal venous pressure of the subject.

In some applications, measuring blood pressure within the vena cava includes measuring an indication of central venous pressure of the subject.

30 In some applications, measuring blood pressure within the vena cava includes measuring an indication of lower-body venous pressure of the subject.

In some applications, the method further includes identifying the subject as suffering from a condition selected from the group consisting of: cardiac dysfunction, congestive heart failure, reduced renal blood flow, increased renal vascular resistance, arterial hypertension, diabetes, and kidney dysfunction, and placing the tube within the subject's vena cava includes
5 placing the tube within the subject's vena cava, in response to identifying the subject as suffering from the selected condition.

In some applications, placing the tube within the subject's vena cava includes treating the selected condition by reducing renal venous pressure of the subject.

There is further provided, in accordance with some applications of the present
10 invention, a method for use with renal veins and a vena cava of a subject, the method including:

placing a first nozzle in the subject's vena cava upstream of junctions of the vena cava with all of the subject's renal veins, such that the first nozzle converges in a direction of antegrade blood flow through the vena cava; and

15 placing a second nozzle in the subject's vena cava downstream of the junctions of the vena cava with all of the subject's renal veins.

In some applications, placing the second nozzle in the subject's vena cava includes placing the second nozzle in the subject's vena cava, such that the second nozzle converges in the direction of antegrade blood flow through the vena cava.

20 In some applications, placing the second nozzle in the subject's vena cava includes placing the second nozzle in the subject's vena cava, such that the second nozzle diverges in the direction of antegrade blood flow through the vena cava.

In some applications, the method further includes:

measuring blood pressure within the vena cava; and

25 modulating a diameter of an opening defined by the first nozzle responsively to the measured blood pressure.

In some applications, measuring blood pressure within the vena cava includes measuring an indication of renal venous pressure of the subject.

In some applications, measuring blood pressure within the vena cava includes
30 measuring an indication of central venous pressure of the subject.

In some applications, measuring blood pressure within the vena cava includes measuring an indication of lower-body venous pressure of the subject.

In some applications, the method further includes modulating a diameter of an opening defined by the second nozzle responsively to the measured blood pressure.

5 In some applications, the method further includes:
measuring blood pressure within the vena cava; and
modulating a diameter of an opening defined by the second nozzle responsively to the measured blood pressure.

10 In some applications, measuring blood pressure within the vena cava includes measuring an indication of renal venous pressure of the subject.

In some applications, measuring blood pressure within the vena cava includes measuring an indication of central venous pressure of the subject.

In some applications, measuring blood pressure within the vena cava includes measuring an indication of lower-body venous pressure of the subject.

15 In some applications, the method further includes identifying the subject as suffering from a condition selected from the group consisting of: cardiac dysfunction, congestive heart failure, reduced renal blood flow, increased renal vascular resistance, arterial hypertension, diabetes, and kidney dysfunction, and placing the first and second nozzles in the subject's vena cava includes placing the first and second nozzles in the subject's vena cava, in response
20 to identifying the subject as suffering from the selected condition.

In some applications, placing the first and second nozzles in the subject's vena cava includes treating the selected condition by reducing renal venous pressure of the subject.

25 There is further provided, in accordance with some applications of the present invention, apparatus for use with renal veins and a vena cava of a subject, the apparatus including:

a first nozzle configured to be placed in the subject's vena cava upstream of junctions of the vena cava with all of the subject's renal veins, such that the first nozzle converges in a direction of antegrade blood flow through the vena cava; and

30 a second nozzle in the subject's vena cava downstream of the junctions of the vena cava with all of the subject's renal veins.

In some applications, the second nozzle is configured to be placed in the subject's vena cava, such that the second nozzle converges in the direction of antegrade blood flow through the vena cava.

5 In some applications, the second nozzle is configured to be placed in the subject's vena cava, such that the second nozzle diverges in the direction of antegrade blood flow through the vena cava.

In some applications, the apparatus further includes:

one or more blood pressure sensors configured to measure blood pressure within the vena cava; and

10 a computer processor configured to modulate a diameter of an opening defined by the first nozzle responsively to the measured blood pressure.

In some applications, the one or more blood pressure sensors are configured to measure an indication of renal venous pressure of the subject.

15 In some applications, the one or more blood pressure sensors are configured to measure an indication of central venous pressure of the subject.

In some applications, the one or more blood pressure sensors are configured to measure an indication of lower-body venous pressure of the subject.

20 In some applications, the computer processor is further configured to modulate a diameter of an opening defined by the second nozzle responsively to the measured blood pressure.

In some applications, the apparatus further includes:

one or more blood pressure sensors configured to measure blood pressure within the vena cava; and

25 a computer processor configured to modulate a diameter of an opening defined by the second nozzle responsively to the measured blood pressure.

In some applications, the one or more blood pressure sensors are configured to measure an indication of renal venous pressure of the subject.

In some applications, the one or more blood pressure sensors are configured to measure an indication of central venous pressure of the subject.

In some applications, the one or more blood pressure sensors are configured to measure an indication of lower-body venous pressure of the subject.

The present invention will be more fully understood from the following detailed description of embodiments thereof, taken together with the drawings, in which:

5

BRIEF DESCRIPTION OF THE DRAWINGS

Fig. 1 is a schematic illustration of a venturi tube disposed inside a subject's vena cava, in accordance with some applications of the present invention;

Fig. 2 is a schematic illustration of the venturi tube and a support frame for supporting the venturi tube inside the vena cava, in accordance with some applications of the present invention;

Fig. 3 is a schematic illustration of first and second nozzles disposed inside a subject's vena cava, in accordance with some applications of the present invention;

Fig. 4 is a schematic illustration of first and second nozzles disposed inside a subject's vena cava, in accordance with some applications of the present invention;

Fig. 5 is a schematic illustration of a nozzle and a pump disposed inside a subject's vena cava, in accordance with some applications of the present invention; and

Fig. 6 is a graph showing the results of calculations that were performed to model the effects of placing a venturi tube inside a subject's vena cava, in accordance with some applications of the present invention.

20

DETAILED DESCRIPTION OF EMBODIMENTS

Reference is now made to Fig. 1, which is a schematic illustration of a venturi tube 20 disposed inside a subject's vena cava 22, in accordance with some applications of the present invention. Reference is also made to Fig. 2, which is a schematic illustration of venturi tube 20 and a support frame 24 for supporting the venturi tube inside the vena cava, in accordance with some applications of the present invention.

Venturi tube 20 is typically placed inside the subject's vena cava in order to provide chronic treatment for a subject suffering from cardiac dysfunction, congestive heart failure, low renal blood flow, high renal vascular resistance, arterial hypertension, diabetes, and/or kidney dysfunction. Typically, venturi tube 20 and support frame 24 are inserted into the

subject's vena cava via a delivery device, such as a catheter (not shown). For example, the catheter may be advanced to the subject's vena cava via any one of the subject's femoral vein, subclavian vein, or jugular vein.

5 For some applications, the support frame is made of a shape-memory alloy, such as nitinol. The venturi tube is typically made of a blood-impermeable material (e.g., polyester, polyurethane, and/or a different polymer), and is coupled to the support frame (for example, via stitching, or via an adhesive). The support frame and the venturi tube are inserted into the vena cava, while in constrained configurations inside the delivery device. Upon being released from the delivery device, inside the vena cava, the support frame and the venturi tube
10 assume their non-constrained configurations by virtue of the support frame having been shape set to its non-constrained configuration. The support frame and the venturi tube are shown in their non-constrained configurations in Figs. 1 and 2.

Venturi tube 20 (when disposed in its non-constrained configuration) defines a flared upstream portion 26 that diverges toward an upstream end 28 of the tube, and a flared
15 downstream portion 30 that diverges toward a downstream end 32 of the tube, such that a central portion 34 of the tube is narrower than at the ends of the tube. The tube defines a plurality of lateral openings 36. The tube is placed within the subject's vena cava, such that the downstream portion of the tube is sealed with respect to the inner wall of the vena cava at a location 38 that is downstream of junctions of the vena cava with all of the subject's renal
20 veins 39, and the upstream portion is sealed with respect to the inner wall of the vena cava at a location 40 that is upstream of junctions of the vena cava with all of the subject's renal veins. Typically, the flared upstream and downstream portions of the tube become sealed with respect to the inner wall of the vena cava, by virtue of the flared portions of the tube being coupled (e.g., stitched, or bonded with adhesive) to the support frame, and the support frame
25 radially expanding such that the support frame contacts the inner wall of the vena cava.

The tube, when placed in the vena cava in the above-described manner, is configured to cause blood flow through the tube to undergo the venturi effect as it passes through the tube. That is, the tube generates a region of low pressure between the ends of the tube, due to the blood flowing through narrow central portion 34 of the tube. Pressure within the central
30 portion of the tube is lower than the pressure in the subject's renal veins in the absence of the tube. Therefore, blood from the subject's renal veins is drawn into the tube, via the one or

more lateral openings 36 defined by the tube. In this manner, pressure within the subject's renal veins is reduced.

Typically, the reduced pressure within the central portion of the tube causes pressure within the region of the vena cava that surrounds the tube to be reduced. For some applications, due to the reduced pressure within the region of the vena cava that surrounds the tube, in the absence of support frame 24, the walls of the vena cava would collapse inwardly around against the tube. Typically, the support frame holds open the walls of the vena cava in the region surrounding the tube, such that the walls of the vena cava do not collapse inwardly as a result of the reduced pressure in the region of the vena cava surrounding the tube.

For some applications, the one or more lateral openings 36 are shaped to converge toward the longitudinal axis of the tube, as shown in the enlarged portion of Fig. 2. By being shaped in this shape, the lateral openings are configured to direct blood to flow into the interior of the tube from outside the tube.

With reference to Fig. 2, typically, (in its non-constrained configuration) inner diameter D1 of the tube at the location at which the inner diameter is at its maximum (which is typically toward the ends of the tube) is greater than 12 mm (e.g., greater than 18 mm) and/or less than 40 mm (e.g., less than 28 mm), e.g., 12-40 mm, or 18-28 mm. It is noted that, for some applications (not shown), there is a slight convergence of the tube at the ends of the tube, such that the inner diameter of the tube is at its maximum at locations that are slightly inset from the ends of the tube. Typically, (in its non-constrained configuration) inner diameter D2 of the tube at the location at which the inner diameter is at its minimum (which is typically toward the longitudinal center of the tube) is greater than 3 mm (e.g., greater than 4 mm) and/or less than 8 mm (e.g., less than 6 mm), e.g., 3-8 mm, or 4-6 mm. For some applications, as shown in Figs. 1 and 2, the tube is at its minimum diameter (D2) over a length of up to 6 cm (e.g., between 0.5 and 6 cm, or between 2 and 6 cm), such that the narrowest portion of the tube has an elongate cylindrical shape that extends over this length. Typically, the ratio of D1 to D2 is greater than 3:1, e.g., greater than 4:1. Alternatively (application not shown), the flared downstream portion (which diverges toward to the downstream end of the tube) abuts the flared upstream portion (which diverges toward the upstream end of the tube), such that the tube is at its minimum inner diameter only at a single longitudinal location, at which the diverging upstream portion abuts the diverging downstream portion.

For some applications, a total length L of tube 20 is greater than 20 mm (e.g., greater than 50 mm) and/or less than 160 mm (e.g., less than 120 mm), e.g., 20-160 mm, or 50-120 mm.

Typically, tube 20 is placed inside the vena cava of a subject suffering from cardiac dysfunction, congestive heart failure, low renal blood flow, high renal vascular resistance, arterial hypertension, diabetes, and/or kidney dysfunction. Typically, placing tube 20 in the vena cava of such a subject causes a lowering and flattening of the subject's renal vein pressure profile, even though the subject's central venous pressure is elevated, e.g., as described with reference to Fig. 4B of WO 14/141284 to Schwammenthal, which is incorporated herein by reference.

Typically, due to the reduction in pressure in the renal veins that is caused by the placing tube 20 inside the vena cava, perfusion of the subject's kidney increases. In turn, this may cause pressure in the renal veins to rise relative to the pressure in the renal veins immediately subsequent to placing tube 20 inside the vena cava, due to increased blood flow into the renal vein. Typically, even after perfusion of the kidney increases, the placement of tube 20 inside the vena cava is configured to maintain the pressure in the renal vein at a lower value than the pressure in the renal vein before the placement of tube 20 inside the vena cava.

It is noted that, for some applications, due to the reduction in pressure in the renal vein that is caused by the placement of tube 20 inside the vena cava, the subject's renal vascular resistance decreases, in accordance with physiological mechanisms that are described, for example, in an article by Haddy et al., entitled "Effect of elevation of intraluminal pressure on renal vascular resistance" (Circulation Research, 1956), which is incorporated herein by reference. It is further noted that a treatment of the subject that increases renal perfusion by increasing blood pressure in the subject's renal arteries would typically not effect the aforementioned physiological mechanisms.

Typically, when placement of tube 20 inside the vena cava is used to reduce pressure in the subject's renal veins, it is expected that there will be an improved responsiveness by the subject to administration of diuretics to the subject, due to the reduction in renal venous pressure. Therefore, for some applications, a reduced dosage of diuretics may be administered to the subject relative to a dosage of diuretics that would be administered to the subject in the absence of performing the techniques described herein. Alternatively, a regular

dosage of diuretics may be administered to the subject, but the diuretics may have a greater effect on the subject, due to the reduction in renal venous pressure.

Typically, high central venous pressure leads to a high level of blood pressure within the heart, which in turn leads to the release of atrial natriuretic peptide (ANP) and B-type natriuretic peptide (BNP) by the subject, both of which act as natural diuretics. For some applications, when placement of tube 20 inside the vena cava is used to reduce pressure in the subject's renal veins, there is expected to be an improved responsiveness by the subject to the release of the natural diuretics by the subject, due to the reduction in renal venous pressure. For some applications, since the subject's central venous pressure is not lowered by placement of tube 20 inside the vena cava, it is expected that the subject will continue to release atrial natriuretic peptide (ANP) and B-type natriuretic peptide (BNP), even while the subject's renal venous pressure is reduced by the placement of tube 20 inside the vena cava. Thus, for some applications, placement of tube 20 inside the vena cava may result in the subject continuing to release atrial natriuretic peptide (ANP) and B-type natriuretic peptide (BNP), as well as resulting in the effectiveness of the aforementioned natural diuretics being greater than the effectiveness of the diuretics in the absence of the placement of tube 20 inside the vena cava.

Reference is now made to Figs. 3 and 4, which are schematic illustrations of a first nozzle 50 and a second nozzle 52 disposed inside vena cava 22, in accordance with some applications of the present invention. For some applications, a generally similar effect to that described above with reference to the placement of tube 20 in the vena cava is achieved by placing first nozzle 50 in the subject's vena cava upstream of junctions of the vena cava with all of the subject's renal veins 39, such that the first nozzle converges in a direction of antegrade blood flow through the vena cava, and placing a second nozzle 52 in the subject's vena cava downstream of the junctions of the vena cava with all of the subject's renal veins. Due to the convergence of nozzle 50, blood flowing through the nozzle undergoes the venturi effect, thereby creating a region 54 within the vena cava downstream of the nozzle that has a lower blood pressure than the blood pressure in the renal veins in the absence of the nozzle. Therefore, blood from the subject's renal veins is drawn into region within the vena cava that is downstream of the nozzle. In this manner, pressure within the subject's renal veins is reduced.

For some applications, second nozzle 52 is placed in the subject's vena cava, such that the second nozzle converges in the direction of antegrade blood flow through the vena cava,

as shown in Fig. 3. The second nozzle is configured to impede backflow of blood toward low pressure region 54 from regions within the vena cava that are downstream of the junctions of the vena cava with the subject's renal veins. Alternatively, the second nozzle is placed in the subject's vena cava, such that the second nozzle diverges in the direction of antegrade blood flow through the vena cava (i.e., the second nozzle converges in the direction of retrograde blood flow through the vena cava), as shown in Fig. 4. The second nozzle is configured to impede backflow of blood toward low pressure region 54 from regions within the vena cava that are downstream of the junctions of the vena cava with the subject's renal veins. Furthermore, the second nozzle is configured to cause any blood that does flow back, via the second nozzle toward the low-pressure region, to undergo the venturi effect by virtue of having flowed through the nozzle. Therefore, backflowing blood that passes through the nozzle is caused to be at low pressure once it passes through the nozzle.

Reference is now made to Fig. 5, which is a schematic illustration of nozzle 50 and a blood pump 60 disposed inside a subject's vena cava, in accordance with some applications of the present invention. Nozzle 50 is generally as described hereinabove. The nozzle is placed in the subject's vena cava 22 upstream of junctions of the vena cava with all of the subject's renal veins 39, such that the nozzle converges in a direction of antegrade blood flow through the vena cava.

Blood pump 60 is placed in the subject's vena cava downstream of the junctions of the vena cava with all of the subject's renal veins and is configured to pump blood in the downstream (i.e., antegrade) direction, toward the subject's right atrium.

Typically, nozzle 50 is configured to partially occlude the subject's vena cava upstream of the junctions of the vena cava with the subject's renal veins. The nozzle is configured to partially occlude the subject's vena cava such that, in response to the pumping of the downstream blood pump, there is not a substantial increase of blood flow from the subject's lower body toward the subject heart, but such that region 54 of low pressure within the vena cava is generated, between the nozzle and the blood pump, within which the blood pressure is lower than the subject's central venous pressure. In addition, due the convergence of nozzle 50, blood flowing through the nozzle undergoes the venturi effect, thereby adding to the reduction in pressure within region 54, relative to central venous pressure. Typically, by generating a region of low pressure, blood flow from the renal veins into the vena cava increases, thereby lowering renal blood pressure and enhancing renal perfusion. It is noted

that the nozzle is configured to partially occlude, but not to totally occlude, the vena cava, in such a manner as to generate a region of low pressure within the vena cava, but to allow a substantial flow of blood through the vena cava.

For some applications, blood pump 60 includes a radially-expandable impeller 62 disposed inside a radially-expandable impeller cage 64. Typically, nozzle 50 and blood pump 60 are disposed at the end of a catheter 66. The impeller and the cage of the blood pump are shape set such as to assume radially-expanded configurations thereof in the absence of any radially-constraining force acting upon the impeller and the cage. For some applications, an engagement mechanism engages the impeller and the cage with respect to one another, such that in response to the cage becoming radially constrained the impeller becomes radially constrained, e.g., in accordance with apparatus and methods described in described in WO 14/141284 to Schwammenthal, which is incorporated herein by reference. In general, the blood pump is generally similar to the blood pumps described in WO 14/141284 to Schwammenthal, WO 15/177793 to Schwammenthal, and/or WO 16/185473 to Schwammenthal, all of which are incorporated herein by reference.

For some applications, one or more blood pressure sensors 68, 70, and/or 72 are disposed on catheter 66, respectively, downstream of pump 60, between pump 60 and nozzle 50, and upstream of nozzle 50. Thus, the blood pressure measured by blood pressure sensor 68 is indicative of central venous pressure, the blood pressure measured by blood pressure sensor 70 is indicative of renal venous pressure, and the blood pressure measured by blood pressure sensor 72 is indicative of lower-body venous pressure. For some applications, a control unit modulates the pumping of the blood by pump 60 responsively to the pressure measured by one or more of the pressure sensors, for example, as described in WO 14/141284 to Schwammenthal, WO 15/177793 to Schwammenthal, and/or International Patent Application WO 16/185473 to Schwammenthal, all of which are incorporated herein by reference. The control unit is typically a computer processor 69 that includes hardware components.

For some applications, the extent to which nozzle 50 occludes the vena cava is controllable. For example, as shown the nozzle may be constructed from a frame 56 (which is typically made of a shape-memory material, such as nitinol) and a blood-impermeable material 58 (e.g., polyester, polyurethane, and/or a different polymer) that is supported by the frame. The frame of the nozzle may be expandable (e.g., by heating the frame, or by applying

an electrical current to the frame), such that the diameter of the opening defined by the nozzle is controllable. For some applications, the extent to which nozzle 50 occludes the vena cava is modulated by a control unit (e.g., control unit 69), responsively to blood pressure measurements that are measured by blood pressure sensor 68, 70, and/or 72. The control unit
5 is typically a computer processor (e.g., computer processor 69) that includes hardware components. For some applications, a nozzle that is controllable such that the diameter of the opening defined by the nozzle may be modulated as described in the present paragraph, is used even in the absence of blood pump 60. For example, in the configurations shown in
10 Figs. 3 and 4, nozzle 50 and/or nozzle 52 may be controllable such that the diameter of the opening defined by the nozzle may be modulated, as described in the present paragraph.

For some applications, nozzle 50 is used in the absence of both nozzle 52 and blood pump 60. Typically, the nozzle is configured to partially occlude the subject's vena cava such as to reduce the subject's central venous pressure. Alternatively or additionally, due the convergence of nozzle 50, blood flowing through the nozzle undergoes the venturi effect,
15 thereby adding to the reduction in pressure within region 54, relative to central venous pressure. Typically, by generating a region of low pressure, blood flow from the renal veins into the vena cava increases, thereby lowering renal blood pressure and enhancing renal perfusion. For some such applications, nozzle 50 is controllable by a control unit, such that the diameter of the opening defined by the nozzle may be modulated. Typically, the control
20 unit is a computer processor (e.g., computer processor 69) that includes hardware components. For example, the control unit may modulate the diameter of the opening defined by the nozzle responsively to blood pressure measurements that are measured by blood pressure sensor 68, 70, and/or 72.

Although Fig. 5 shows the blood pump and the nozzle disposed on a catheter that is
25 inserted into the vena cava from above the junctions of the vena cava with the subject's renal veins (e.g., via the subject's subclavian vein or jugular vein), for some applications, the blood pump and the nozzle are disposed on a catheter that is inserted into the vena cava from below the junctions of the vena cava with the subject's renal veins (e.g., via the subject's femoral vein), *mutatis mutandis*. Alternatively or additionally, the nozzle is disposed on a first
30 catheter which is inserted into the vena cava from below the junctions of the vena cava with the subject's renal veins (e.g., via the subject's femoral vein), and the blood pump is disposed

on a second catheter, which inserted into the vena cava from above the junctions of the vena cava with the subject's renal veins (e.g., via the subject's subclavian vein, or jugular vein).

Although blood pump 60 is described as being an impeller-based pump, the scope of the present invention includes using any other type of pump for pumping blood in the manner described herein, *mutatis mutandis*. For example, a roller pump, an Archimedes screw pump, a centrifugal pump, a pneumatic pump, and/or a compression pump may be used.

Typically, the apparatus shown in Fig. 5 is used to apply an acute treatment to the subject, in order to treat the subject for one or more of the conditions described herein.

Reference is now made to Fig. 6, which is a graph showing the results of calculations that were performed to model blood flowing through the renal veins and the vena cava via a venturi tube having characteristics generally as described herein with reference to Figs. 1 and 2. Pressure reduction within the renal veins was calculated for tubes having respective minimum inner diameters. Fig. 6 shows the pressure reduction that was calculated for the venturi tubes having the respective inner diameters.

It may be observed that as the minimum inner diameter is reduced the resultant pressure reduction within the renal veins is greater (i.e., the pressure within the renal veins is reduced by increasing amounts). These results indicate that techniques as described herein may cause a reduction in renal venous pressure, and that reducing the minimum inner diameter of the venturi tube (or of the nozzle, for applications as described with reference to Figs. 3 and 4) may cause a greater reduction in the renal venous pressure. It is noted that there is a lower limit to the minimum inner diameter of the tube or the nozzle that can be used, due to the fact that below a given minimum diameter, the drag force that would be generated by the tube (or the nozzle) on the blood flow through the tube (or the nozzle) would impede blood flow via the tube (or the nozzle), which would reduce blood flow toward the heart via the vena cava, thereby endangering the patient. The inventors hypothesize that the lower limit for the minimum diameter of the tube or the nozzle is 3 mm.

Therefore, as described hereinabove, typically, (in its non-constrained configuration) inner diameter D2 of the tube at the location at which the inner diameter is at its minimum (which is typically toward the longitudinal center of the tube) is greater than 3 mm (e.g., greater than 4 mm) and/or less than 8 mm (e.g., less than 6 mm), e.g., 3-8 mm, or 4-6 mm. Similarly, the minimum diameter of the nozzle (i.e., the diameter at the tip of the nozzle) is

typically greater than 3 mm (e.g., greater than 4 mm) and/or less than 8 mm (e.g., less than 6 mm), e.g., 3-8 mm, or 4-6 mm.

For some applications, venturi tube 20 is configured such that the minimum inner diameter of the tube may be modulated, for example, by constructing the tube in a similar manner to that described with reference to nozzle 50 as shown in Fig. 5, and using techniques as described with reference to nozzle 50 as shown in Fig. 5, *mutatis mutandis*. For some such applications, the minimum inner diameter of the tube is modulated by a control unit. Typically, the control unit is a computer processor (e.g., computer processor 69, shown in Fig. 5) that includes hardware components. For example, the control unit may modulate the minimum inner diameter of the tube responsively to blood pressure measurements that are indicative of central venous pressure, renal venous pressure, and/or lower-body venous pressure, as described hereinabove, with reference to blood pressure sensor 68, 70, and/or 72. It is noted that venturi tube 20, nozzles 50 and 52, and blood pump 60 are generally described as being placed within the subject's vena cava in the vicinity of the junctions of the renal veins with the vena cava. However, the scope of the present invention includes placing venturi tube 20, nozzles 50 and 52, and/or blood pump 60 in any vein that has junctions with a tributary vessel, in accordance with the techniques described herein, *mutatis mutandis*. For example, venturi tube 20, nozzles 50 and 52, and/or blood pump 60 may be placed within the vena cava in the vicinity of junctions of the vena cava with the subject's hepatic veins, and may be used to increase blood flow from the subject's hepatic veins into the subject's vena cava, in order to increase perfusion of the subject's liver, *mutatis mutandis*. Alternatively or additionally, venturi tube 20, nozzles 50 and 52, and/or blood pump 60 could be placed within the subclavian vein or jugular vein at junctions of the vein with a lymph duct and could be used to increase flow of lymphatic fluid from the lymph duct into the vein, *mutatis mutandis*.

The scope of the present invention includes combining any of the apparatus and methods described herein with any of the apparatus and methods described in one or more of the following applications, all of which are incorporated herein by reference:

International Patent Application PCT/IL2016/050525 to Schwammenthal (published as WO 16/185473), filed May 18, 2016, entitled "Blood pump," which US Provisional Patent Application 62/162,881 to Schwammenthal, filed May 18, 2015, entitled "Blood pump;"

International Patent Application PCT/IL2015/050532 to Schwammenthal (published as WO 15/177793), filed May 19, 2015, entitled "Blood pump," which claims priority from

US Provisional Patent Application 62/000,192 to Schwammenthal, filed May 19, 2014, entitled "Blood pump;"

International Patent Application PCT/IL2014/050289 to Schwammenthal (published as WO 14/141284), filed March 13, 2014, entitled "Renal pump," which claims priority from
5 (a) US Provisional Patent Application 61/779,803 to Schwammenthal, filed March 13, 2013, entitled "Renal pump," and (b) US Provisional Patent Application 61/914,475 to Schwammenthal, filed December 11, 2013, entitled "Renal pump;"

US Patent Application 14/567,439 to Tuval (issued as US 9,764,113), filed Dec. 11, 2014, entitled "Curved catheter," which claims priority from US Provisional Patent
10 Application 61/914,470 to Tuval, filed Dec. 11, 2013, entitled "Curved catheter;" and

International Patent Application PCT/IL2013/050495 to Tuval (published as WO 13/183060), filed June 06, 2013, entitled "Prosthetic renal valve," which claims priority from US Provisional Patent Application 61/656,244 to Tuval, filed June 06, 2012, entitled "Prosthetic renal valve."

15 There is therefore provided, in accordance with some applications of the present invention, the following inventive concepts:

Inventive concept 1. A method for use with renal veins and a vena cava of a subject, the method comprising:

20 placing a nozzle in the subject's vena cava upstream of junctions of the vena cava with all of the subject's renal veins, such that the first nozzle converges in a direction of antegrade blood flow through the vena cava;

placing a blood pump in the subject's vena cava downstream of the junctions of the vena cava with all of the subject's renal veins; and

25 operating the blood pump to blood pump in direction of antegrade blood flow through the vena cava.

Inventive concept 2. Apparatus for use with renal veins and a vena cava of a subject, the apparatus comprising:

30 a nozzle configured to be placed in the subject's vena cava upstream of junctions of the vena cava with all of the subject's renal veins, such that the first nozzle converges in a direction of antegrade blood flow through the vena cava; and

a blood pump configured to be placed in the subject's vena cava downstream of the junctions of the vena cava with all of the subject's renal veins, and to blood pump in the direction of antegrade blood flow through the vena cava.

5 It will be appreciated by persons skilled in the art that the present invention is not limited to what has been particularly shown and described hereinabove. Rather, the scope of the present invention includes both combinations and subcombinations of the various features described hereinabove, as well as variations and modifications thereof that are not in the prior art, which would occur to persons skilled in the art upon reading the foregoing description.

CLAIMS

1. Apparatus for use with renal veins and a vena cava of a subject, the apparatus comprising:

a tube that defines:

5 a flared downstream portion thereof that diverges toward a downstream end of the tube, and a flared upstream portion thereof that diverges toward an upstream end of the tube, such that a central portion of the tube is narrower than at the ends of the tube, and

a plurality of lateral openings; and

10 a support frame configured to support the tube within the subject's vena cava, such that:

the downstream portion of the tube is sealed with respect to an inner wall of the vena cava at a location that is downstream of junctions of the vena cava with all of the subject's renal veins, and

15 the upstream portion of the tube is sealed with respect to the inner wall of the vena cava at a location that is upstream of junctions of the vena cava with all of the subject's renal veins.

2. The apparatus according to claim 1, wherein the plurality of lateral openings are shaped such as to converge toward a longitudinal axis of the tube.

20 3. The apparatus according to claim 1, wherein an inner diameter of the tube at a location at which the inner diameter is at its maximum is greater than 12 mm.

4. The apparatus according to claim 1, wherein an inner diameter of the tube at a location at which the inner diameter is at its minimum is less than 8 mm.

25 5. The apparatus according to claim 1, wherein a ratio between an inner diameter of the tube at a location at which the inner diameter is at its maximum and an inner diameter of the tube at a location at which the inner diameter is at its minimum is greater than 3:1.

6. The apparatus according to claim 1, wherein a length of the tube is greater than 20 mm.

7. The apparatus according to any one of claims 1-6, further comprising:

one or more blood pressure sensors configured to measure blood pressure within the vena cava; and

a computer processor configured to modulate a diameter of the central portion of the tube responsively to the measured blood pressure.

5 8. The apparatus according to claim 7, wherein the one or more blood pressure sensors are configured to measure an indication of renal venous pressure of the subject.

9. The apparatus according to claim 7, wherein the one or more blood pressure sensors are configured to measure an indication of central venous pressure of the subject.

10 10. The apparatus according to claim 7, wherein the one or more blood pressure sensors are configured to measure an indication of lower-body venous pressure of the subject.

11. A method for use with renal veins and a vena cava of a subject, the method comprising:

providing a tube that defines:

15 a flared downstream portion thereof that diverges toward a downstream end of the tube, and a flared upstream portion thereof that diverges toward an upstream end of the tube, such that a central portion of the tube is narrower than at the ends of the tube, and

a plurality of lateral openings; and

placing the tube within the subject's vena cava, such that:

20 the downstream portion of the tube is sealed with respect to an inner wall of the vena cava at a location that is downstream of junctions of the vena cava with all of the subject's renal veins, and

25 the upstream portion of the tube is sealed with respect to the inner wall of the vena cava at a location that is upstream of junctions of the vena cava with all of the subject's renal veins.

12. The method according to claim 11, wherein providing the tube comprises providing the tube, the plurality of lateral openings being shaped such as to converge toward a longitudinal axis of the tube.

30 13. The method according to claim 11, wherein providing the tube comprises providing the tube, an inner diameter of the tube at a location at which the inner diameter is at its maximum being greater than 12 mm.

14. The method according to claim 11, wherein providing the tube comprises providing the tube, an inner diameter of the tube at a location at which the inner diameter is at its minimum being less than 8 mm.
15. The method according to claim 11, wherein providing the tube comprises providing the tube, a ratio between an inner diameter of the tube at a location at which the inner diameter is at its maximum and an inner diameter of the tube at a location at which the inner diameter is at its minimum being greater than 3:1.
16. The method according to claim 11, wherein providing the tube comprises providing the tube, a length of the tube being greater than 20 mm.
17. The method according to any one of claims 11-16, further comprising:
measuring blood pressure within the vena cava; and
modulating a diameter of the central portion of the tube responsively to the measured blood pressure.
18. The method according to claim 17, wherein measuring blood pressure within the vena cava comprises measuring an indication of renal venous pressure of the subject.
19. The method according to claim 17, wherein measuring blood pressure within the vena cava comprises measuring an indication of central venous pressure of the subject.
20. The method according to claim 17, wherein measuring blood pressure within the vena cava comprises measuring an indication of lower-body venous pressure of the subject.
21. The method according to any one of claims 11-16, further comprising identifying the subject as suffering from a condition selected from the group consisting of: cardiac dysfunction, congestive heart failure, reduced renal blood flow, increased renal vascular resistance, arterial hypertension, diabetes, and kidney dysfunction, wherein placing the tube within the subject's vena cava comprises placing the tube within the subject's vena cava, in response to identifying the subject as suffering from the selected condition.
22. The method according to claim 21, wherein placing the tube within the subject's vena cava comprises treating the selected condition by reducing renal venous pressure of the subject.
23. A method for use with renal veins and a vena cava of a subject, the method comprising:

placing a first nozzle in the subject's vena cava upstream of junctions of the vena cava with all of the subject's renal veins, such that the first nozzle converges in a direction of antegrade blood flow through the vena cava; and

5 placing a second nozzle in the subject's vena cava downstream of the junctions of the vena cava with all of the subject's renal veins.

24. The method according to claim 23, wherein placing the second nozzle in the subject's vena cava comprises placing the second nozzle in the subject's vena cava, such that the second nozzle converges in the direction of antegrade blood flow through the vena cava.

10 25. The method according to claim 23, wherein placing the second nozzle in the subject's vena cava comprises placing the second nozzle in the subject's vena cava, such that the second nozzle diverges in the direction of antegrade blood flow through the vena cava.

26. The method according to any one of claims 23-25, further comprising:
measuring blood pressure within the vena cava; and
modulating a diameter of an opening defined by the first nozzle responsively to the
15 measured blood pressure.

27. The method according to claim 26, wherein measuring blood pressure within the vena cava comprises measuring an indication of renal venous pressure of the subject.

28. The method according to claim 26, wherein measuring blood pressure within the vena cava comprises measuring an indication of central venous pressure of the subject.

20 29. The method according to claim 26, wherein measuring blood pressure within the vena cava comprises measuring an indication of lower-body venous pressure of the subject.

30. The method according to claim 26, further comprising modulating a diameter of an opening defined by the second nozzle responsively to the measured blood pressure.

25 31. The method according to one of claims 23-25, further comprising:
measuring blood pressure within the vena cava; and
modulating a diameter of an opening defined by the second nozzle responsively to the measured blood pressure.

32. The method according to claim 31, wherein measuring blood pressure within the vena cava comprises measuring an indication of renal venous pressure of the subject.

33. The method according to claim 31, wherein measuring blood pressure within the vena cava comprises measuring an indication of central venous pressure of the subject.

34. The method according to claim 31, wherein measuring blood pressure within the vena cava comprises measuring an indication of lower-body venous pressure of the subject.

5 35. The method according to one of claims 23-25, further comprising identifying the subject as suffering from a condition selected from the group consisting of: cardiac dysfunction, congestive heart failure, reduced renal blood flow, increased renal vascular resistance, arterial hypertension, diabetes, and kidney dysfunction, wherein placing the first and second nozzles in the subject's vena cava comprises placing the first and second nozzles
10 in the subject's vena cava, in response to identifying the subject as suffering from the selected condition.

36. The method according to claim 35, wherein placing the first and second nozzles in the subject's vena cava comprises treating the selected condition by reducing renal venous pressure of the subject.

15 37. Apparatus for use with renal veins and a vena cava of a subject, the apparatus comprising:

a first nozzle configured to be placed in the subject's vena cava upstream of junctions of the vena cava with all of the subject's renal veins, such that the first nozzle converges in a direction of antegrade blood flow through the vena cava; and

20 a second nozzle in the subject's vena cava downstream of the junctions of the vena cava with all of the subject's renal veins.

38. The apparatus according to claim 37, wherein the second nozzle is configured to be placed in the subject's vena cava, such that the second nozzle converges in the direction of antegrade blood flow through the vena cava.

25 39. The apparatus according to claim 37, wherein the second nozzle is configured to be placed in the subject's vena cava, such that the second nozzle diverges in the direction of antegrade blood flow through the vena cava.

40. The apparatus according to any one of claims 37-39, further comprising:

30 one or more blood pressure sensors configured to measure blood pressure within the vena cava; and

a computer processor configured to modulate a diameter of an opening defined by the first nozzle responsively to the measured blood pressure.

41. The apparatus according to claim 40, wherein the one or more blood pressure sensors are configured to measure an indication of renal venous pressure of the subject.

5 42. The apparatus according to claim 40, wherein the one or more blood pressure sensors are configured to measure an indication of central venous pressure of the subject.

43. The apparatus according to claim 40, wherein the one or more blood pressure sensors are configured to measure an indication of lower-body venous pressure of the subject.

10 44. The apparatus according to claim 40, wherein the computer processor is further configured to modulate a diameter of an opening defined by the second nozzle responsively to the measured blood pressure.

45. The apparatus according to any one of claims 37-39, further comprising:
one or more blood pressure sensors configured to measure blood pressure within the vena cava; and

15 a computer processor configured to modulate a diameter of an opening defined by the second nozzle responsively to the measured blood pressure.

46. The apparatus according to claim 45, wherein the one or more blood pressure sensors are configured to measure an indication of renal venous pressure of the subject.

20 47. The apparatus according to claim 45, wherein the one or more blood pressure sensors are configured to measure an indication of central venous pressure of the subject.

48. The apparatus according to claim 45, wherein the one or more blood pressure sensors are configured to measure an indication of lower-body venous pressure of the subject.

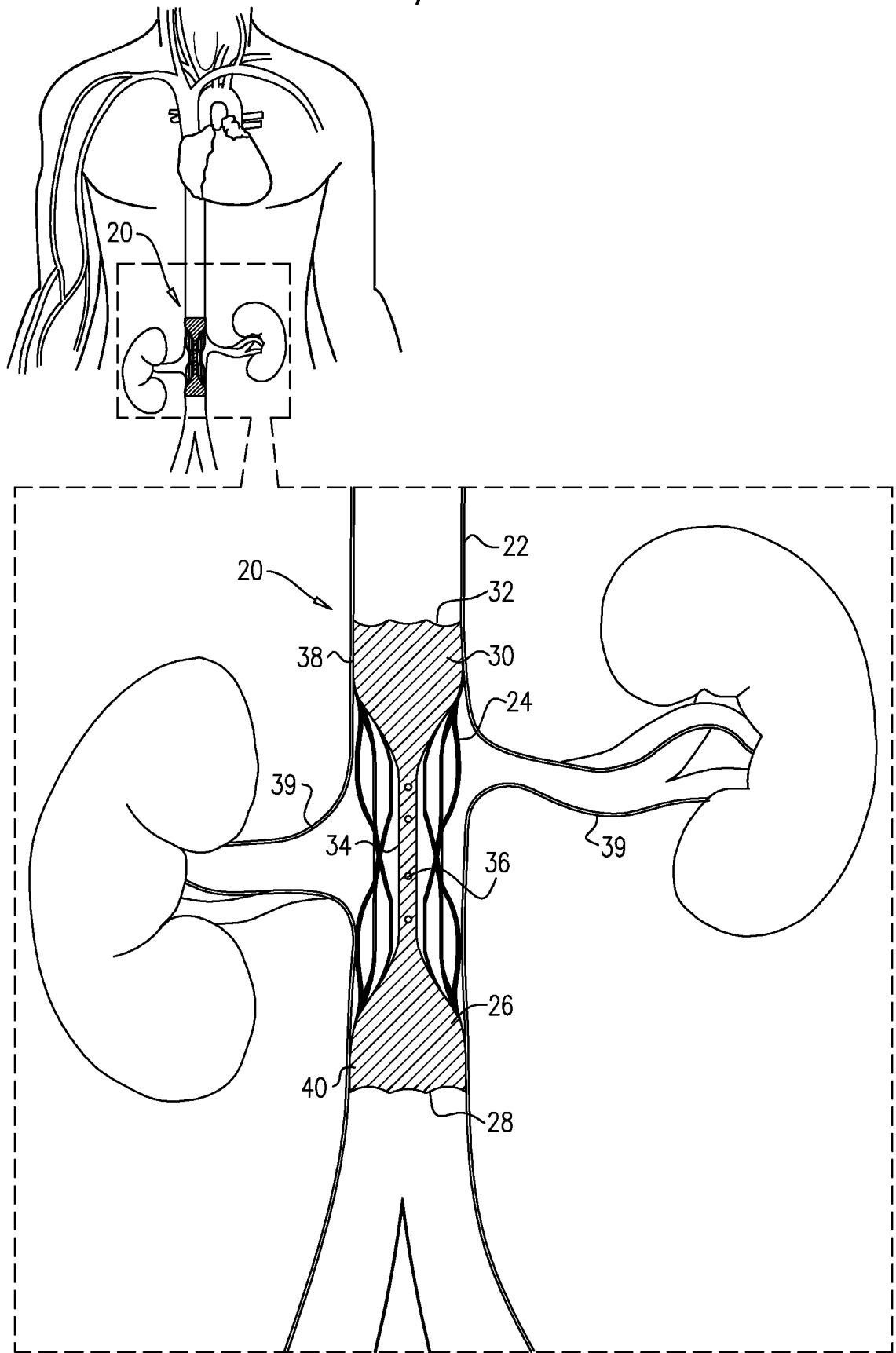

FIG. 1

2/6

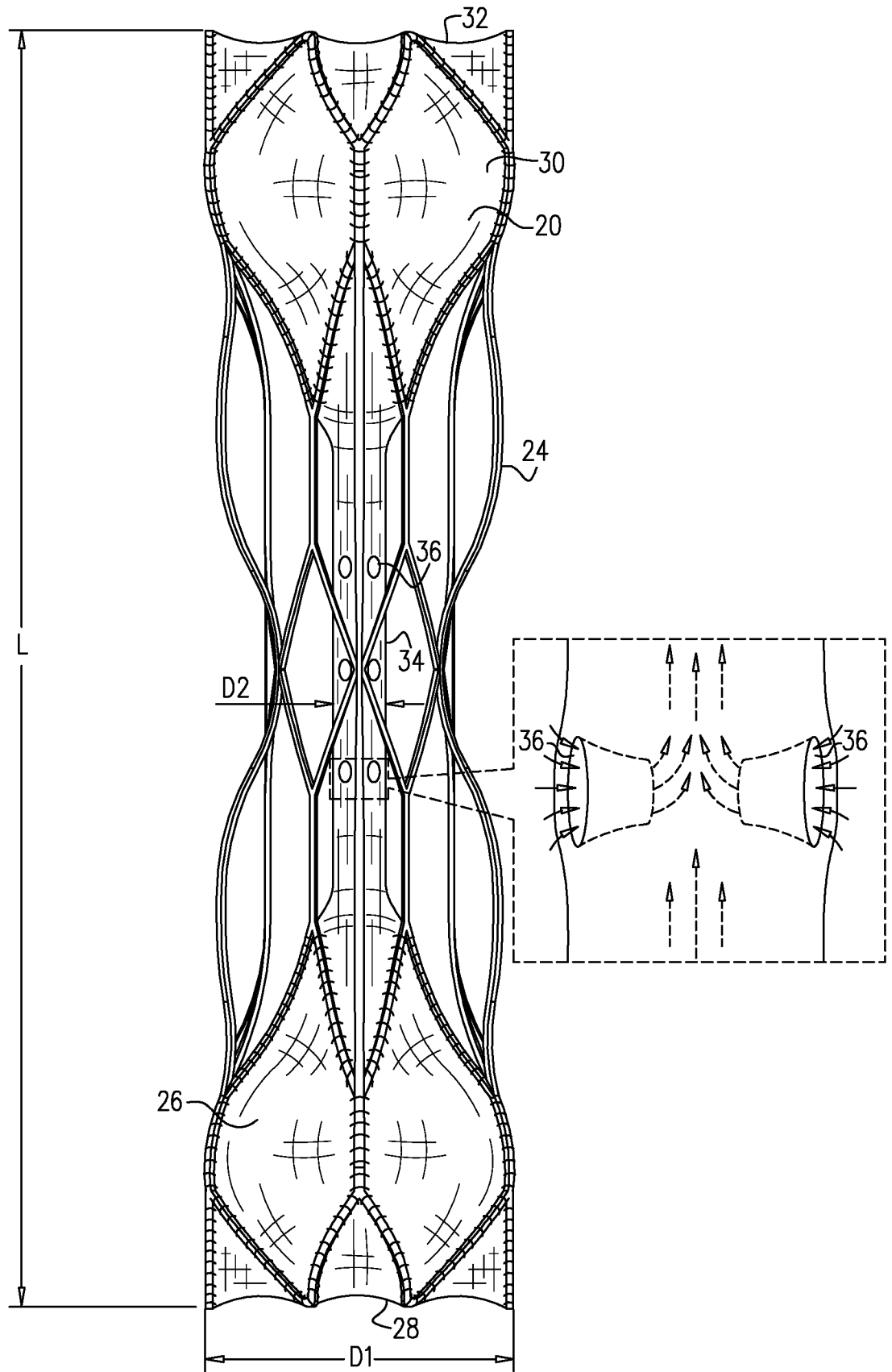

FIG. 2

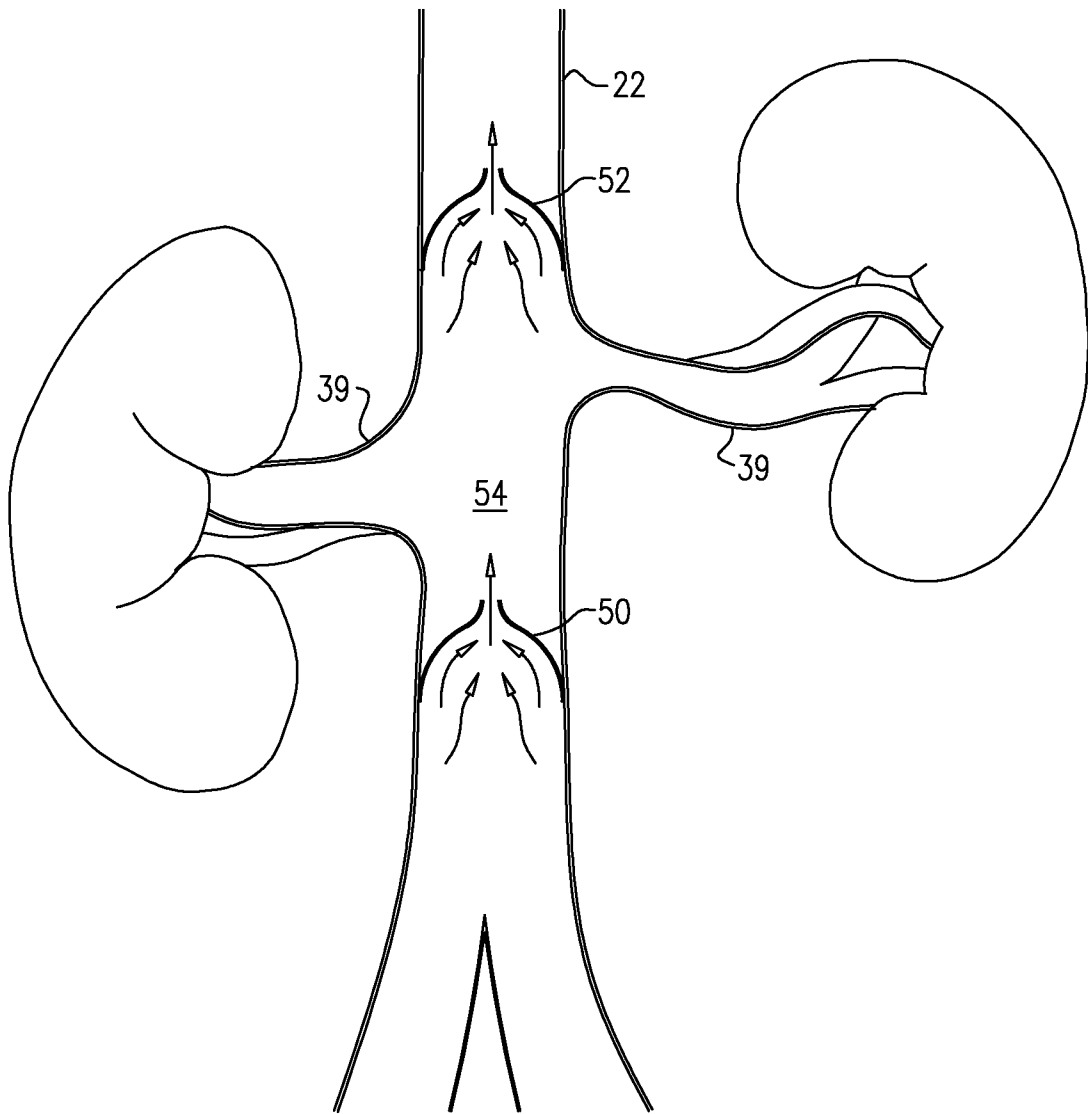

FIG. 3

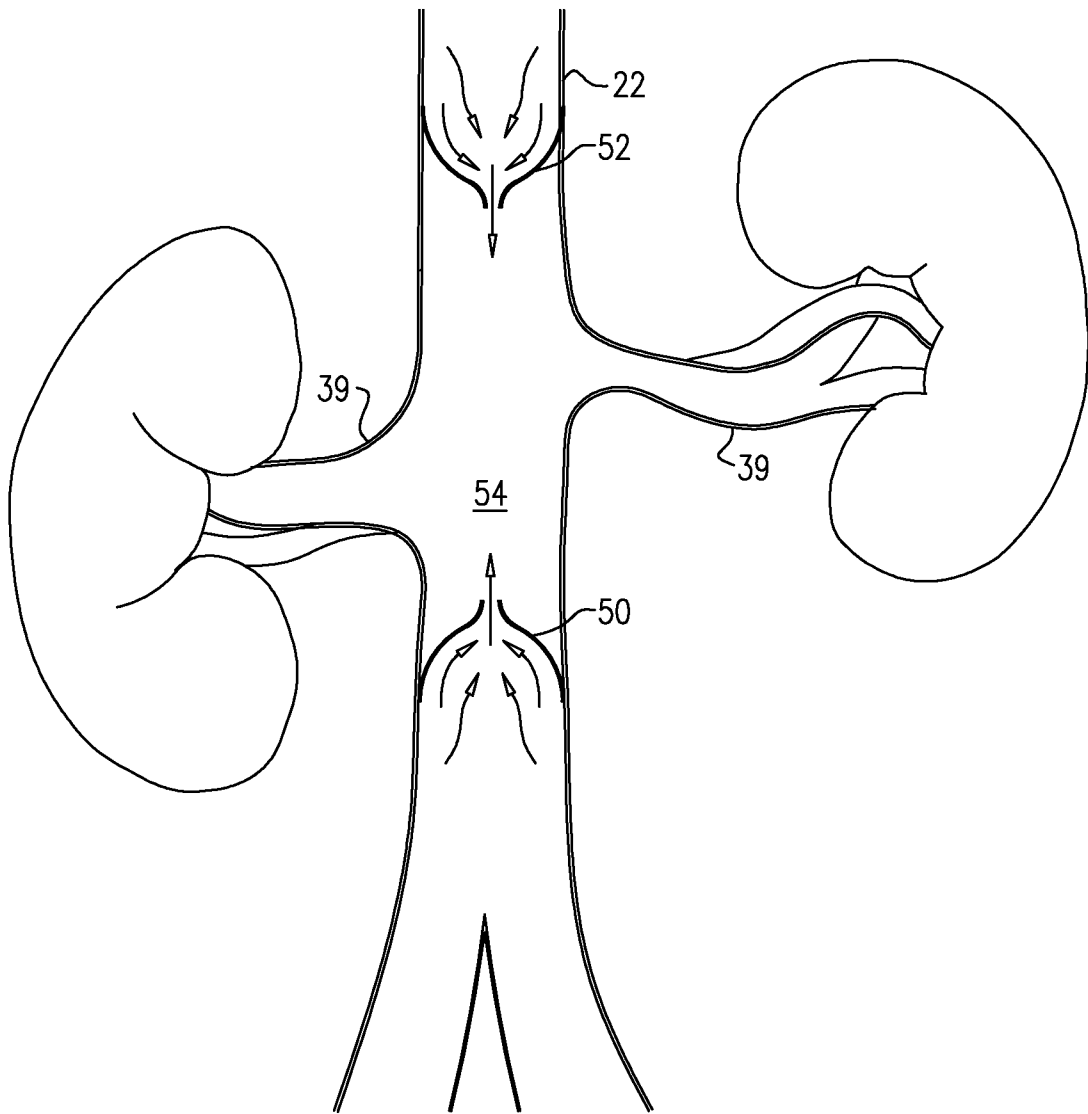

FIG. 4

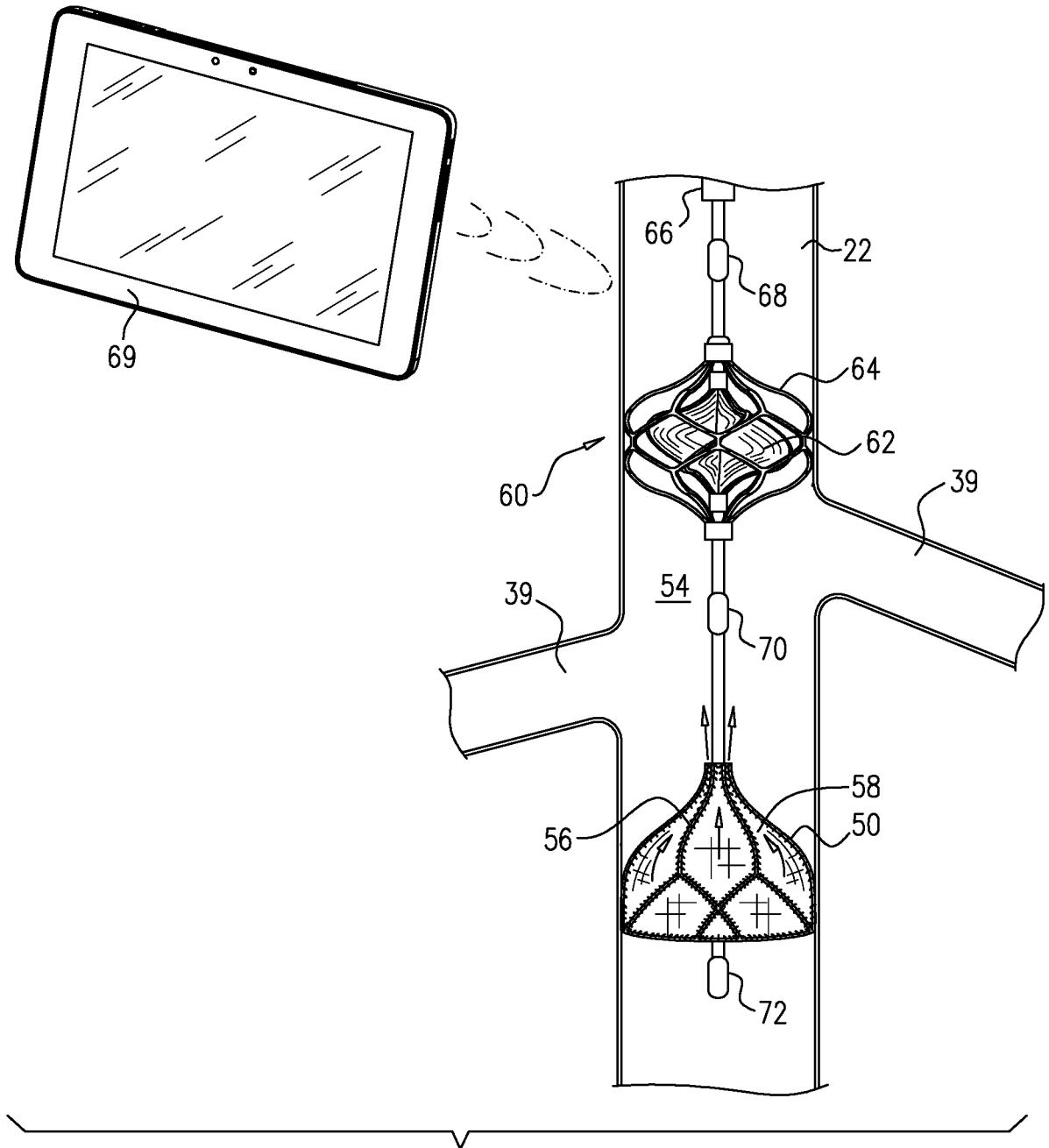

FIG. 5

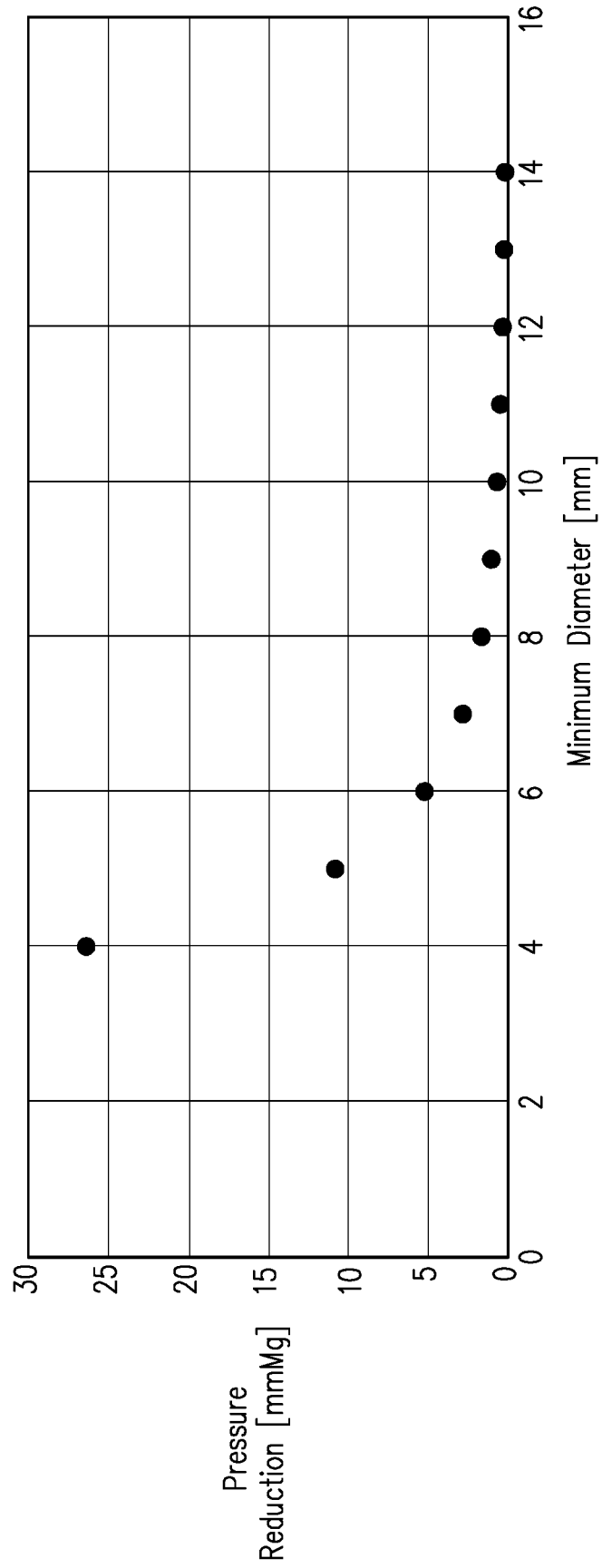

FIG. 6

INTERNATIONAL SEARCH REPORT

International application No
PCT/IL2017/051092

A. CLASSIFICATION OF SUBJECT MATTER
 INV. A61F2/06 A61F2/07
 ADD.
 According to International Patent Classification (IPC) or to both national classification and IPC

B. FIELDS SEARCHED
 Minimum documentation searched (classification system followed by classification symbols)
 A61F

Documentation searched other than minimum documentation to the extent that such documents are included in the fields searched

Electronic data base consulted during the international search (name of data base and, where practicable, search terms used)
 EPO-Internal, WPI Data

C. DOCUMENTS CONSIDERED TO BE RELEVANT

Category*	Citation of document, with indication, where appropriate, of the relevant passages	Relevant to claim No.
A	WO 2014/141284 A2 (MAGENTA MEDICAL LTD [IL]) 18 September 2014 (2014-09-18) cited in the application page 71, line 19 - page 78, line 12 figures 10A-G	1-10
A	WO 2007/127477 A2 (SYNECOR LLC [US]; WILLIAMS MICHAEL S [US]; FIFER DANIEL W [US]) 8 November 2007 (2007-11-08) page 6, line 3 - line 11; figure 8	37-48

Further documents are listed in the continuation of Box C.

See patent family annex.

* Special categories of cited documents :

- "A" document defining the general state of the art which is not considered to be of particular relevance
- "E" earlier application or patent but published on or after the international filing date
- "L" document which may throw doubts on priority claim(s) or which is cited to establish the publication date of another citation or other special reason (as specified)
- "O" document referring to an oral disclosure, use, exhibition or other means
- "P" document published prior to the international filing date but later than the priority date claimed

- "T" later document published after the international filing date or priority date and not in conflict with the application but cited to understand the principle or theory underlying the invention
- "X" document of particular relevance; the claimed invention cannot be considered novel or cannot be considered to involve an inventive step when the document is taken alone
- "Y" document of particular relevance; the claimed invention cannot be considered to involve an inventive step when the document is combined with one or more other such documents, such combination being obvious to a person skilled in the art
- "&" document member of the same patent family

Date of the actual completion of the international search
 8 January 2018

Date of mailing of the international search report
 16/01/2018

Name and mailing address of the ISA/
 European Patent Office, P.B. 5818 Patentlaan 2
 NL - 2280 HV Rijswijk
 Tel. (+31-70) 340-2040,
 Fax: (+31-70) 340-3016

Authorized officer
 Geuer, Melanie

INTERNATIONAL SEARCH REPORT

International application No.
PCT/IL2017/051092

Box No. II Observations where certain claims were found unsearchable (Continuation of item 2 of first sheet)

This international search report has not been established in respect of certain claims under Article 17(2)(a) for the following reasons:

1. Claims Nos.: **11-36**
because they relate to subject matter not required to be searched by this Authority, namely:
Rule 39.1(iv) PCT - Method for treatment of the human or animal body by surgery
2. Claims Nos.:
because they relate to parts of the international application that do not comply with the prescribed requirements to such an extent that no meaningful international search can be carried out, specifically:
3. Claims Nos.:
because they are dependent claims and are not drafted in accordance with the second and third sentences of Rule 6.4(a).

Box No. III Observations where unity of invention is lacking (Continuation of item 3 of first sheet)

This International Searching Authority found multiple inventions in this international application, as follows:

1. As all required additional search fees were timely paid by the applicant, this international search report covers all searchable claims.
2. As all searchable claims could be searched without effort justifying an additional fees, this Authority did not invite payment of additional fees.
3. As only some of the required additional search fees were timely paid by the applicant, this international search report covers only those claims for which fees were paid, specifically claims Nos.:
4. No required additional search fees were timely paid by the applicant. Consequently, this international search report is restricted to the invention first mentioned in the claims; it is covered by claims Nos.:

Remark on Protest

- The additional search fees were accompanied by the applicant's protest and, where applicable, the payment of a protest fee.
- The additional search fees were accompanied by the applicant's protest but the applicable protest fee was not paid within the time limit specified in the invitation.
- No protest accompanied the payment of additional search fees.

INTERNATIONAL SEARCH REPORT

Information on patent family members

International application No

PCT/IL2017/051092

Patent document cited in search report	Publication date	Patent family member(s)	Publication date
WO 2014141284 A2	18-09-2014	AU 2014229150 A1	24-09-2015
		CA 2905349 A1	18-09-2014
		CN 105473063 A	06-04-2016
		EP 2967361 A2	20-01-2016
		JP 2016509950 A	04-04-2016
		US 2016022890 A1	28-01-2016
		US 2016051741 A1	25-02-2016
		WO 2014141284 A2	18-09-2014
WO 2007127477 A2	08-11-2007	US 2007293808 A1	20-12-2007
		WO 2007127477 A2	08-11-2007