

Jan. 22, 1957

J. W. TIMMERMAN

2,778,379

CONTROL SYSTEM FOR FLUID OPERATED MECHANISM

Filed Jan. 2, 1952

2 Sheets-Sheet 1

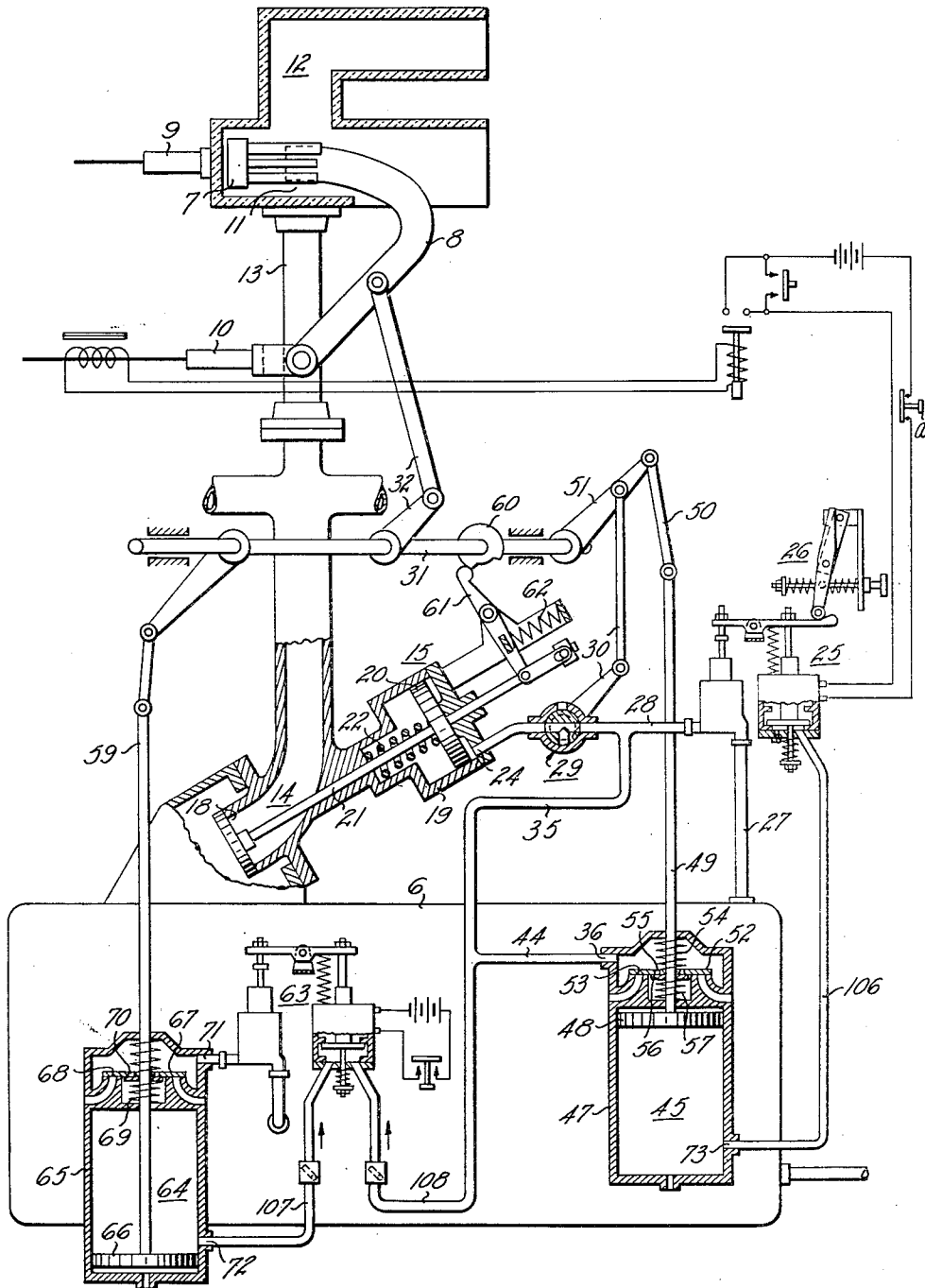

Fig. 1

Inventor
Julius W. Timmerman
by *Waver F. B. Lindsey*
Attorneys

Jan. 22, 1957

J. W. TIMMERMAN

2,778,379

CONTROL SYSTEM FOR FLUID OPERATED MECHANISM

Filed Jan. 2, 1952

2 Sheets-Sheet 2

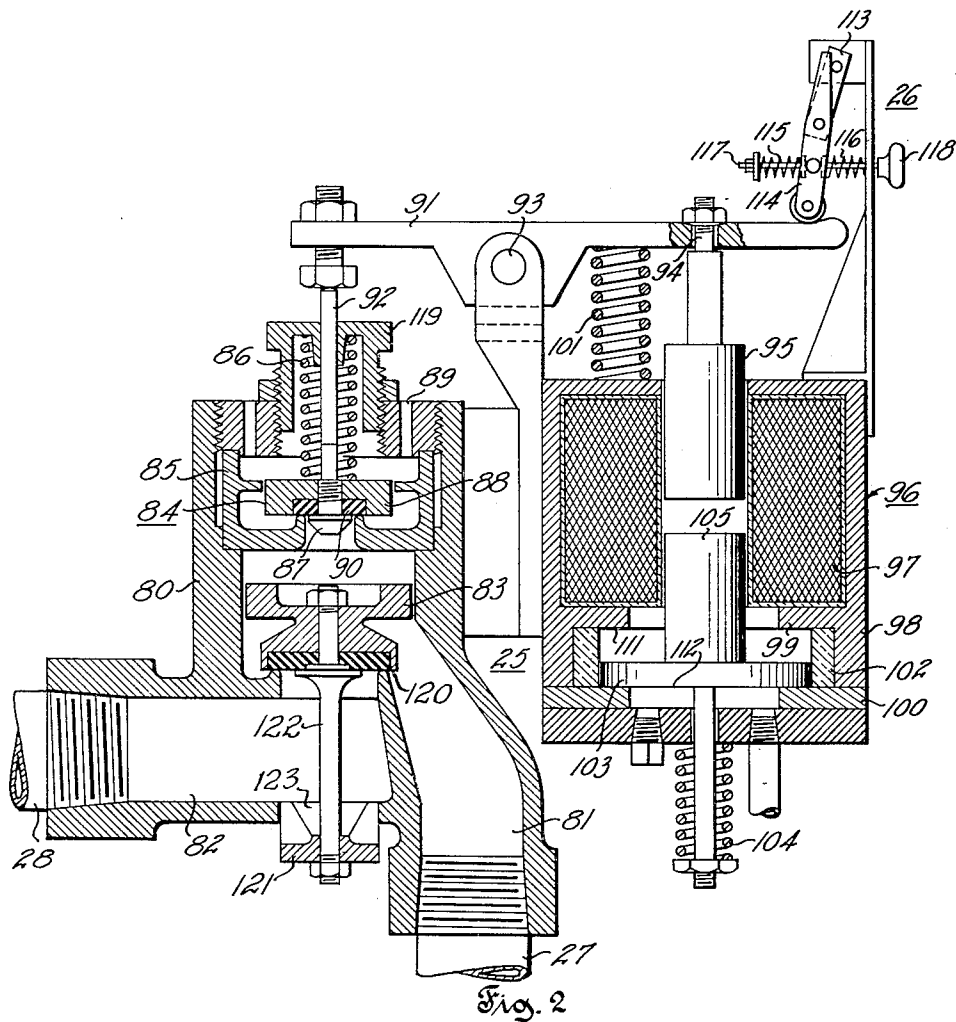

Inventor
Julius W. Timmerman
by Warren F. B. Lindsay
Attorney

2,778,379

CONTROL SYSTEM FOR FLUID OPERATED
MECHANISMJulius W. Timmerman, Waukesha, Wis., assignor to Allis-
Chalmers Manufacturing Company, Milwaukee, Wis.

Application January 2, 1952, Serial No. 264,370

7 Claims. (Cl. 137—620)

This invention relates to fluid operated mechanisms and more particularly to control arrangements for fluid operated motors.

Heretofore control arrangements for fluid operated motors have been complicated and expensive to manufacture. Therefore, it is desirable to provide a control arrangement which is simple in design and dependable. The control arrangement should be responsive to the motor position so as to eliminate the possibility of a complete control system operation before the motor has moved a predetermined distance.

In a preferred embodiment of the invention claimed a new and improved control system for fluid operated mechanisms is provided which comprises, among other things, a valve of the differential pressure type connected to a source of fluid under pressure. This valve is provided with a main valve member which is controlled by a pilot valve. The opening and closing of the pilot valve affects the pressures acting on the main valve member to cause opening and closing of the main valve member. A spring biased lever arm is provided for holding the pilot valve closed when the arm is in one position but permitting the pilot valve to open when the arm is moved to another position. An electromagnetic means actuates the lever arm to release the pilot valve in response to a predetermined condition in the power circuit controlled. A first pneumatic means opens the pilot valve if a predetermined fluid pressure exists on one side of the pilot valve after the lever arm has been moved to release the pilot valve, and a second pneumatic means is actuated to close the pilot valve after a pneumatic motor has moved a predetermined distance.

It is therefore one object of the present invention to provide a new and improved control system in which the control arrangement is responsive to movement of a pneumatic motor in two directions.

Another object of this invention is to provide a new and improved control arrangement for fluid operated mechanisms in which a low pressure interlock prevents a main valve from being opened under low pressure conditions.

A further object of this invention is to provide a new and improved solenoid control mechanism in which the flux paths are shifted by a pneumatic means.

A still further object of this invention is to provide an electromagnetic control arrangement which may be manually operated by a new and improved means.

A still further object of this invention is to provide a new and improved control valve which is simple in design and dependable under all operating conditions.

Objects and advantages other than those set forth will be apparent from the following description when read in connection with the accompanying drawings, in which:

Fig. 1 is a diagrammatic view partly in elevation of a circuit interrupting system embodying the present invention; and

Fig. 2 is an enlarged view in axial cross section through a pneumatic control valve illustrated in Fig. 1.

Referring more particularly to the drawings by characters of reference, Fig. 1 illustrates a circuit breaker including as a constructive element thereof a reservoir 6 constituting a source of supply of fluid under pressure, which will be assumed herein to be compressed air supplied from a suitable compressor (not shown). Although in general, circuit breakers of the type herein considered are provided with a plurality of similar pole structures, one for each phase of a polyphase electric circuit, only one such pole structure or pole unit is shown in the figure and the circuit breaker will be described in detail as if it were of the single pole unit type.

The circuit breaker comprises a fixed arcing contact 7 and a cooperating movable arcing contact 8 connected in an electric circuit through terminal studs 9 and 10. The arcing contacts are mounted to engage within an arcing chamber 11 which is aligned with an arc chute 12. The arcing chamber 11 is axially aligned with a hollow insulator 13 which provides a connection between reservoir 6 and arcing chamber 11 through a suitable blast valve 14 for directing a blast of arc extinguishing fluid under pressure between the arcing contacts and through the arcing chamber 11.

The blast valve 14 is actuated by a fluid motor 15 and controls a blast inlet port 18. Motor 15 comprises a cylinder 19, a blast valve cracking piston 20, a piston rod 21, a spring 22, and an inlet port 24.

A solenoid operated valve 25 opens automatically if a fault current occurs on the power circuit controlled or if valve 25 is manually actuated by a pushbutton arrangement 26. Valve 25 controls the flow of fluid under pressure from reservoir 6 through a pipe line 27, valve 28, pipe line 28, a three way valve 29, and inlet port 24 of cylinder 19 to the blast valve cracking piston 20 of fluid motor 15.

Valve 29 is connected by linkage 30 to a lever 51 mounted on a rocking shaft 31. A linkage 32 connects rocking shaft 31 with the movable sickle shaped arcing contact 8. If arcing contact 8 is in the closed position thereof, valve 29 is in such an angular position as to admit compressed air to cylinder 19 through inlet port 24. Upon opening of valve 25 compressed air from the reservoir 6 is admitted to a pipe line 35 which is connected to a pipe line 44 and an inlet port 36 of a fluid motor 45. Near the end of the opening stroke of the breaker the three way valve 29 is rotated approximately ninety degrees clockwise and in so doing dumps to atmosphere the air from the right side of piston 20 of fluid motor 15.

Fluid motor 45 comprises a cylinder 47, a piston 48 having a piston rod 49 movable therewith and connected through a connecting rod 50 and a crank 51 to shaft 31. Motor 45 is provided with a dumping valve 52 which releases pressure above piston 48 at or near the end of its upward stroke. Dumping valve 52 is biased against its valve seat 53 by a spring 54. Dumping valve 52 is provided with ports 55 which are controlled by a plate 56 biased in port closing direction by a spring 57.

Shaft 31 is provided with a cam 60 which upon rotation of shaft 31 in contact opening direction releases a lever arm 61 which in turn releases a compressed spring 62. Spring 62 acts on piston rod 21 to maintain blast valve 14 in its open position, even upon dumping of air from the high pressure side of piston 20.

Closing of the arcing contacts is initiated by energizing a solenoid operated valve 63 which is substantially identical to valve 25. Valve 63 connects reservoir 6 to a fluid motor 64.

Fluid motor 64, through the intermediary of linkage 59 causes rotation of shaft 31 to close the arcing contacts 7, 8. Motor 64 comprises a cylinder 65, a piston 66, a

dump valve 67, valve seat 68, spring 69, valve ports 70, inlet port 71, and outlet port 72.

The solenoid operated valves 25 and 63 are substantially identical so that a description of only one valve will be set forth. Valve 25 comprises a casting forming a cylinder 80 provided with a fluid admission opening or port 81 and with an exhaust opening or port 82. Port 81 is connected to pipe line 27 and port 82 is connected to pipe line 28. Cylinder 80 is provided with a differential piston or main valve member 83 which is so arranged in cylinder 80 to provide a passage of predetermined cross section between the lower side of main valve member 83 and the upper side of member 83. Cylinder 80 is provided with a pilot valve 84 the opening of which initiates operation of the main valve member 83. Pilot valve 84 is arranged within a casting 85 which is inserted in cylinder 80. A spring 86 biases valve 84 to valve closed position. Valve 84 is provided with a throttling tip 87 which provides a definite piston area. A small amount of air through the pilot valve 84 lifts the pilot disk or tip 87 high enough against the action of spring 86 to make the overall diameter of piston 88 effective in lift against spring 86. Piston 88 is fitted into casting 85 so as to provide a passage of predetermined cross section for the flow of air from the lower to the upper side of the piston. Piston 88 has the upper side thereof vented to atmosphere through a plurality of vents 89. A resilient sealing material 90 is arranged within piston 88 to form a tight seal when the pilot valve 84 is closed. When the main valve member 83 is moved away from annular valve seat 129 so as to provide a direct passageway between ports 81 and 82 a valve member 121 connected to piston operated valve member 83 by a stem 122 closes opening 123 to prevent the escape of air to atmosphere through opening 123.

The pilot valve 84 is biased closed by a spring biased lever arm 91 which abuts against a push rod 92. Push rod 92 abuts against the pilot valve stem. Lever arm 91 is pivotally mounted at 93 and is arranged to be secured at 94 to an armature 95 of a solenoid 96. Solenoid 96 further comprises a coil 97 and a core or casting 98 of paramagnetic material.

Spring 101 biasing lever arm 91 in valve closing direction is strong enough to hold the pilot valve closed once it is closed but is not strong enough to close the pilot valve once it is sealed opened.

Casting 98 provides at the lower end thereof a cylinder 102 of nonmagnetic material which is fitted with a piston 103 of paramagnetic material. Piston 103 forming a part of a magnetic pole member 105 is biased to its lower position by spring 104 but when actuated upward moves magnetic pole member 105. Pole member 105 actuates armature 95 upward and rotates counterclockwise lever arm 91. Lever arm 91 then biases pilot valve 84 to closed position.

Casting 98 includes members 99 and 100 arranged one at each end of cylinder 102 providing pole surfaces 111 and 112 for magnetically locking the piston 103 in one of two positions.

Piston 103 of valve mechanism 25 may be actuated by the fluid under pressure in cylinder 47 of fluid motor 45 through a port 73 and a pipe line 106. Piston 103 of valve 63 may be actuated by fluid under pressure from cylinder 65 of fluid motor 64 through a pipe line 107 or from fluid under pressure in pipe line 35 through a pipe line 108.

A manual emergency pilot valve tripping mechanism 26 is provided for opening the main valve member 83, if so desired. Mechanism 26 comprises a pair of toggle arms 113 and 114 which are arranged to collapse in one direction only, a pair of springs 115 and 116 arranged on a pull rod 117 and balanced one against the other with the toggle arm 114 arranged in between them. The toggle arms 113 and 114 are manually held rigid and pivoted about an axis to actuate the lever arm 91 to

release the pilot valve 84 and which collapses to return to their original position when the normal pull rod 117 is released. When the pull rod is actuated, spring 115 is compressed enough to overcome spring 101, and the roller mounted on the toggle arms depresses lever 91 to allow the pressure in inlet port 81 to open the pilot valve. Spring 115 then snaps the toggle linkage out of the way of the lever arm 91. Release of the pull button 118 arranged on rod 117 causes the toggle linkage to break and ride up over the lever arm 91 and reset for subsequent trip operations.

Upon the occurrence of a fault condition on the power circuit, solenoid coil 97 of the valve 25 is energized. Armature 95 is actuated to rotate lever arm 91 clockwise about its pivot point 93 to release the pilot valve 84. If the fluid pressure in reservoir 6 is below a predetermined value the leakage of air past main valve member 83, pilot valve 84 and piston 88, will not be enough to lift the pilot valve 84 appreciably from its valve seat. At a predetermined reservoir pressure the leakage of air past main valve member 83 creates a pressure between main valve member 83 and pilot valve 84 great enough to lift the tip 87 of pilot valve 84 to a point where the rate of flow around tip 87 is great enough to build up pressure under piston 88 to raise and snap the pilot valve 84 to its open position and to hold it open. The pressure between main valve member 83 and piston 88 will be reduced to a predetermined low value, thus causing the pressure on the upstream side of main valve member 83 to actuate member 83 to valve open position and to hold it open. The leakage of air past member 83 when in its open position is still great enough to hold open the pilot valve 84. Spring 86 has enough force to hold the pilot valve closed, but not enough force to close it once the pilot valve is sealed open.

The blast of air passing through casting 80 flows through pipe line 28, three way valve 29, inlet port 24 to fluid motor 15. The actuation of piston 20 under the force of the fluid under pressure from inlet port 24 cracks the blast valve 14 open. Compressed air is admitted through pipe line 35 and pipe line 44 to fluid motor 45. Air under pressure passes through ports 55 and actuates plate 56 downward against the bias of spring 57. Fluid under pressure upstream of piston 48 actuates piston 48 downward causing piston rod 49 to rotate shaft 31 clockwise to separate the arcing contacts 7, 8. As a result of the movement of shaft 31 and cam 60 mounted thereon spring 62 is allowed to act on the stem of piston 20 to help actuate blast valve 14 to its open position and to maintain blast valve 14 open even upon dumping of the air from the upstream side of piston 20.

After piston 48 of fluid motor 45 has passed a port 73 in its contact opening movement, air under pressure passes through port 73, pipe line 106 to the under side of piston 103 arranged in cylinder 102. Piston 103 and member 105 are actuated upward and push armature 95 upward to rotate lever arm 91 counterclockwise. Push rod 92 is slidably mounted in a cap 119 and is actuated by lever arm 91 to force pilot valve 84 closed, thereby allowing pressure to build up behind main valve member 83 to close it. Once the pilot valve 84 has been closed by an external force, springs 86 and 101 are strong enough to hold it closed.

When coil 97 is energized, piston 103 of pole member 105 is magnetically locked or sealed in one of two possible positions. If the pressure in pipe line 106 is below a predetermined value piston 103 is in its lower position and the magnetic flux passing through casting 98 passes through pole surfaces 112 and piston 103 to magnetically lock the piston 103 in its lower position. The magnetic flux in casting 98 attracts armature 95 and draws it down to pole member 105, causing lever arm 91 to rotate clockwise and spring 101 to be compressed. Clockwise rotation of lever arm 91 removes the external force from the stem of the pilot valve 84. In the event that

5

coil 97 remains energized after the contacts 7, 8 have separated a predetermined distance, air from pipe lines 35 and 44 passes through fluid motor 45, port 73 in cylinder 47 into pipe line 106. Fluid under pressure in pipe line 106 forces piston 103 and magnetic pole member 105 up and away from the pole surface 112. As the piston 103 reaches the upper limit of its travel the piston 103 is snapped into engagement and is magnetically sealed and locked in the upper position against the pole surface 111. The piston 103 remains in its upper position against the pole surface 111 as long as coil 97 remains energized with a predetermined current.

The upward travel of the pole member 105 pushes armature 95 upward and by virtue of the counterclockwise rotation of lever arm 91 forces the pilot valve 84 closed. As the pilot tip 87 begins to throttle, spring 101 forces closed the pilot valve 84 and holds it closed. Continued energization of the coil 97 holds piston 103 against the pole surfaces 111 and lever arm 91 holds the pilot valve 84 closed even though the pneumatic pressure in line 106 is greatly reduced.

In the event of a "flick" operation of a control button which would energize coil 97 only long enough to allow the pilot valve 84 to lift and seal open, the pilot valve 84 would remain open until the valve mechanism 25 has gone through a complete operation. After the pilot valve has opened, spring 101 is not strong enough to close the valve and compressed air flowing through motor 45 and pipe 106 must raise piston 103 and pole piece 105 to rotate counterclockwise lever arm 91 to move the pilot valve 84 in valve closing direction to the point where the spring 101 takes over and completely closes the pilot valve 84 and the main valve member 83.

The circuit breaker arcing contacts are closed by energizing the coil 97 of solenoid valve 63. This valve operates in the same manner as valve 25 to allow fluid under pressure from reservoir 6 through the main valve member 83 to the fluid motor 64. The actuation of fluid motor 64 closes the arcing contacts 7, 8.

Pipe lines 35 and 108 are connected to the lower side of casting 98 and actuate piston 103 of valve 63 upward to the pilot valve closed position during a circuit breaker opening operation. Thus, if a closing operation is initiated while the breaker is in the act of closing, the opening valve will take preference.

As shown and described the pilot valve 84 is actuated to closed position after a predetermined movement of piston 43 of fluid motor 45 or piston 103 of solenoid operated valve 25. Thus, the pilot valves 25 and 63 are controlled by fluid operated pistons, the positions of which are related to the positions of the arcing contacts 7, 8.

Although but one embodiment of the present invention has been illustrated and described, it will be apparent to those skilled in the art that various changes and modifications may be made therein without departing from the spirit of the invention or from the scope of the appended claims.

It is claimed and desired to secure by Letters Patent:

1. In combination, a conduit for conveying fluid under pressure, a valve connected to said conduit for controlling the flow of fluid through said conduit and comprising a fluid operated valve member, a pilot valve connected to said valve, said pilot valve upon opening thereof reducing the pressure on one side of said valve member to initiate operation of said valve, a lever arm biased to a first position, said lever arm when in said first position biasing said pilot valve to valve seated position and when moved to a second position releasing said pilot valve for operation thereof, means for actuating said lever arm to said second position to release said pilot valve, biasing means for holding said pilot valve closed after release of said lever arm until a predetermined fluid pressure exists at said pilot valve, and pneumatic means actuated upon the flow of fluid through said valve, said pneumatic means actuating said lever arm to close said pilot valve

6

after a predetermined flow of fluid through said conduit.

2. In combination, a conduit for conveying fluid under pressure, a valve connected to said conduit for controlling the flow of fluid through said conduit and comprising a fluid operated valve member, a pilot valve connected to said valve, said pilot valve upon opening thereof reducing the pressure on one side of said valve member to initiate operation of said valve, a pivotally mounted spring biased lever arm, said lever arm when in a first position biasing said pilot valve to valve seated position and when moved to a second position releasing said pilot valve for operation thereof, electromagnetic means for actuating said lever arm to said second position to release said pilot valve, biasing means for holding said pilot valve closed after release of said lever arm until a predetermined fluid pressure exists at said pilot valve, and pneumatic means actuated upon the flow of fluid through said valve, said pneumatic means comprising a cylinder and a piston for actuating said lever arm to close said pilot valve after a predetermined movement of said piston.

3. In combination, a conduit for conveying fluid under pressure, a valve of the differential pressure type connected to said conduit for controlling the flow of fluid through said conduit and comprising a fluid operated valve member, a pilot valve connected to said valve, said pilot valve upon opening thereof reducing the pressure on one side of said valve member to initiate operation of said valve, a pivotally mounted spring biased lever arm, said lever arm when in a first position biasing said pilot valve to valve seated position and when moved to a second position releasing said pilot valve for operation thereof, electro-magnetic means for actuating said lever arm against its biasing means to said second position to release said pilot valve, spring biasing means for holding said pilot valve closed after release of said lever arm until a predetermined fluid pressure exists at said pilot valve, and pneumatic means actuated upon the flow of fluid through said valve, said pneumatic means comprising a cylinder and a piston for actuating said lever arm to close said pilot valve after a predetermined movement of said piston.

4. In combination, a conduit for conveying fluid under pressure, a valve of the differential pressure type connected to said conduit for controlling the flow of fluid through said conduit and comprising a fluid operated valve member, a pilot valve connected to said valve, said pilot valve upon opening thereof reducing the pressure on one side of said valve member to initiate operation of said valve, a pivotally mounted spring biased lever arm, said lever arm when in a first position biasing said pilot valve to valve seated position and when moved to a second position releasing said pilot valve for operation thereof, electromagnetic means for actuating said lever arm to said second position to release said pilot valve, biasing means for holding said pilot valve closed after release of said lever arm until a predetermined fluid pressure exists at said pilot valve, and pneumatic means actuated by the flow of fluid through said pilot valve, said pneumatic means actuating said lever arm to close said pilot valve.

5. In combination, a conduit for conveying fluid under pressure, a valve connected to said conduit for controlling the flow of fluid through said conduit and comprising a fluid operated valve member, a pilot valve connected to said valve, said pilot valve upon opening thereof reducing the pressure on one side of said valve member to initiate operation of said valve, a pivotally mounted spring biased lever arm, said lever arm when in a first position biasing said pilot valve to valve seated position and when moved to a second position releasing said pilot valve for operation thereof, manual means for actuating said lever arm to said second position to release said pilot valve, said manual means comprising a spring biased toggle means which is manually held rigid and pivoted about an axis to actuate said lever arm to release said pilot valve and collapses to return to its original position when said manual

7

means is released, biasing means for holding said pilot valve closed after release of said lever arm until a predetermined fluid pressure exists at said pilot valve, and pneumatic means actuated upon the flow of fluid through said valve for closing said pilot valve after a predetermined flow of fluid through said valve.

6. In combination, a conduit for conveying fluid under pressure, a valve connected to said conduit for controlling the flow of fluid through said conduit and comprising a fluid operated valve member, a pilot valve connected to said valve, said pilot valve upon opening thereof reducing the pressure on one side of said valve member to initiate operation of said valve, a spring biased lever arm, said lever arm when in a first position biasing said pilot valve to valve seated position and when moved to a second position releasing said pilot valve for operation thereof, manual means for actuating said lever arm to said second position to release said pilot valve, said manual means comprising a spring biased toggle held rigid when actuated to rotate said lever arm to release said pilot valve and spring biased to collapse when manually released so as to snap back to its original position, biasing means for holding said pilot valve closed after release of said lever arm until a predetermined fluid pressure exists at said pilot valve, and pneumatic means actuated upon the flow of fluid through said valve for closing said pilot valve after a predetermined flow of fluid through said valve.

7. In combination, a conduit for conveying fluid under pressure, a valve connected to said conduit for controlling the flow of fluid through said conduit and comprising a

8

fluid operated valve member, a pilot valve connected to said valve, said pilot valve upon opening thereof reducing the pressure on one side of said valve member to initiate operation of said valve, a spring biased lever arm, said lever arm when in a first position biasing said pilot valve to valve seated position and when moved to a second position releasing said pilot valve for operation thereof, manual means for actuating said lever arm to said second position to release said pilot valve, said manual means comprising a spring biased toggle held rigid when actuated to rotate said lever arm to release said pilot valve, said toggle being spring biased to disengage from said lever arm with a snap action and being spring biased to collapse when manually released so as to snap back to its original position, biasing means for holding said pilot valve closed after release of said lever arm until a predetermined fluid pressure exists at said pilot valve, and pneumatic means actuated upon the flow of fluid through said valve for closing said pilot valve after a predetermined flow of fluid through said valve.

References Cited in the file of this patent

UNITED STATES PATENTS

25	1,829,708	Belcher	Oct. 27, 1931
	1,871,057	Hook	Aug. 9, 1932
	2,401,144	Dube	Mar. 28, 1946
	2,447,627	Baker	Aug. 24, 1948
	2,497,860	Brown	Feb. 21, 1950
30	2,500,777	Timmerman	Mar. 14, 1950
	2,523,572	Jansson	Sept. 26, 1950