

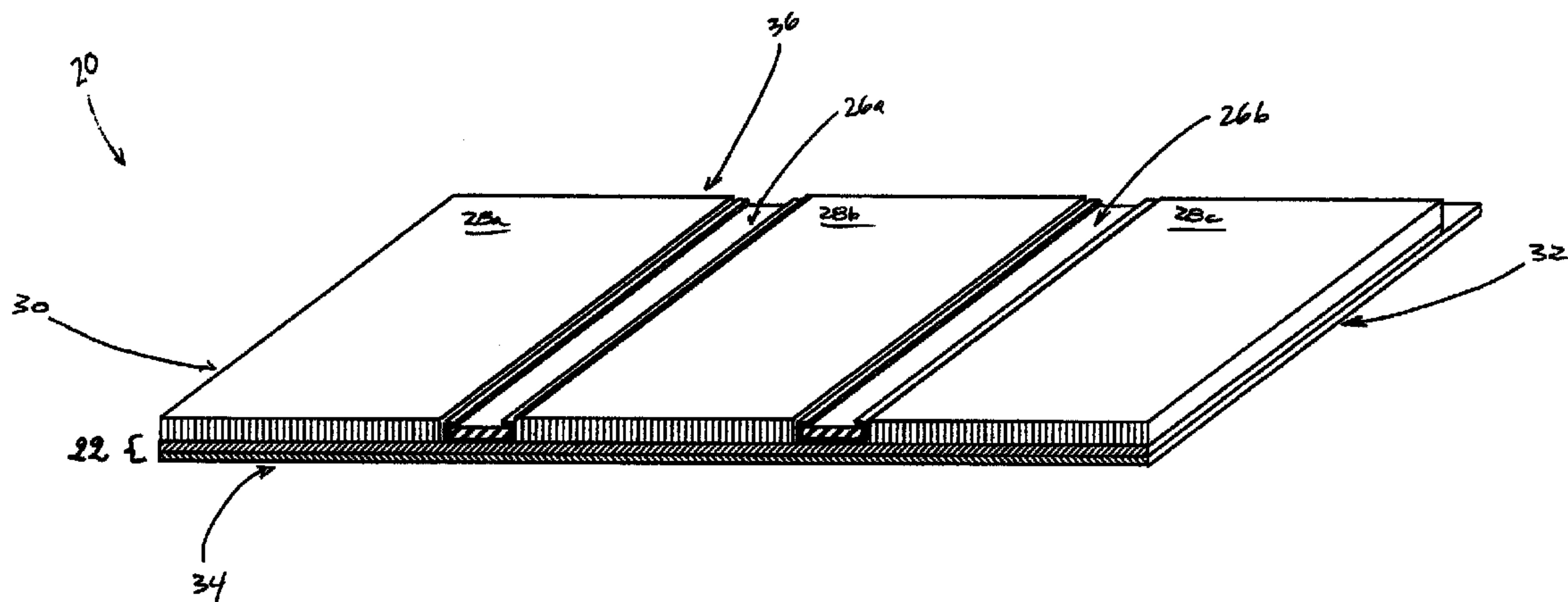

(86) **Date de dépôt PCT/PCT Filing Date:** 2008/11/27
 (87) **Date publication PCT/PCT Publication Date:** 2009/06/04
 (45) **Date de délivrance/Issue Date:** 2016/06/28
 (85) **Entrée phase nationale/National Entry:** 2011/05/27
 (86) **N° demande PCT/PCT Application No.:** CA 2008/002097
 (87) **N° publication PCT/PCT Publication No.:** 2009/067814
 (30) **Priorité/Priority:** 2007/11/28 (US60/990,645)

(51) **Cl.Int./Int.Cl. E04F 15/18** (2006.01),
E04F 21/20 (2006.01)
 (72) **Inventeurs/Inventors:**
FOURNIER, JEAN-ROCK, CA;
MOREAU, STEPHANE, CA
 (73) **Propriétaire/Owner:**
GESTION IMMOBILIERE GT INC., CA
 (74) **Agent:** ROBIC

(54) **Titre : SOUS-COUCHE POUR PARQUET EN BOIS DUR ET REVETEMENT**
 (54) **Title: UNDERLAYMENT FOR HARDWOOD FLOORING AND COVERING**



(57) **Abrégé/Abstract:**

The present invention generally pertains to an underlayment for hardwood flooring or covering. The underlayment comprises a flexible sheet member comprising a vapor barrier and a plurality of fastening members mounted with the flexible sheet member, parallel to one another. Each fastening member comprises a metal sleeve and a piece of wood or fiberboards mounted in the sleeve. Each fastening member is adapted for receiving fasteners therein. The present invention also pertains to a kit for such an underlayment and to a method for assembling the same.



(12) INTERNATIONAL APPLICATION PUBLISHED UNDER THE PATENT COOPERATION TREATY (PCT)

(19) World Intellectual Property Organization
International Bureau



(43) International Publication Date
4 June 2009 (04.06.2009)

PCT

(10) International Publication Number
WO 2009/067814 A1

(51) International Patent Classification:
E04F 15/18 (2006.01) *E04F 21/20* (2006.01)

(21) International Application Number:
PCT/CA2008/002097

(22) International Filing Date:
27 November 2008 (27.11.2008)

(25) Filing Language: English

(26) Publication Language: English

(30) Priority Data:
60/990,645 28 November 2007 (28.11.2007) US

(71) Applicants and

(72) Inventors: **FOURNIER, Jean-Rock** [CA/CA]; 532 Des Grands-Ducs Street, Lévis, Québec G6K 1S6 (CA).
MOREAU, Stéphane [CA/CA]; 1150 De l'Outremer Street, Québec, Québec G2L 3T1 (CA).

(74) Agent: **FASKEN MARTINEAU DUMOULIN LLP**;
Stock Exchange Tower, Suite 3700, 800 Square Victoria,
P.O. Box 242, Montréal, Québec H4Z 1E9 (CA).

(81) Designated States (*unless otherwise indicated, for every kind of national protection available*): AE, AG, AL, AM, AO, AT, AU, AZ, BA, BB, BG, BH, BR, BW, BY, BZ, CA, CH, CN, CO, CR, CU, CZ, DE, DK, DM, DO, DZ, EC, EE, EG, ES, FI, GB, GD, GE, GH, GM, GT, HN, HR, HU, ID, IL, IN, IS, JP, KE, KG, KM, KN, KP, KR, KZ, LA, LC, LK, LR, LS, LT, LU, LY, MA, MD, ME, MG, MK, MN, MW, MX, MY, MZ, NA, NG, NI, NO, NZ, OM, PG, PH, PL, PT, RO, RS, RU, SC, SD, SE, SG, SK, SL, SM, ST, SV, SY, TJ, TM, TN, TR, TT, TZ, UA, UG, US, UZ, VC, VN, ZA, ZM, ZW.

(84) Designated States (*unless otherwise indicated, for every kind of regional protection available*): ARIPO (BW, GH, GM, KE, LS, MW, MZ, NA, SD, SL, SZ, TZ, UG, ZM, ZW), Eurasian (AM, AZ, BY, KG, KZ, MD, RU, TJ, TM), European (AT, BE, BG, CH, CY, CZ, DE, DK, EE, ES, FI, FR, GB, GR, HR, HU, IE, IS, IT, LT, LU, LV, MC, MT, NL, NO, PL, PT, RO, SE, SI, SK, TR), OAPI (BF, BJ, CF, CG, CI, CM, GA, GN, GQ, GW, ML, MR, NE, SN, TD, TG).

Published:

— with international search report

(54) Title: UNDERLAYMENT FOR HARDWOOD FLOORING AND COVERING

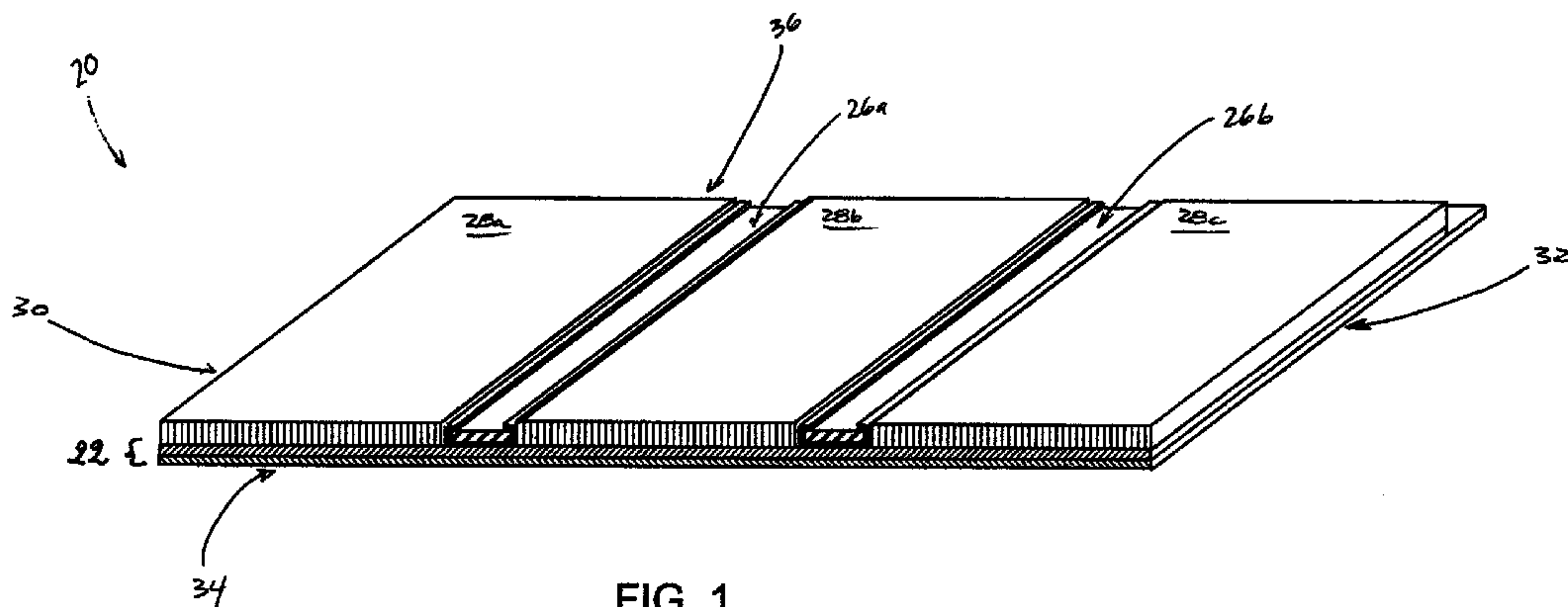

FIG. 1

(57) Abstract: The present invention generally pertains to an underlayment for hardwood flooring or covering. The underlayment comprises a flexible sheet member comprising a vapor barrier and a plurality of fastening members mounted with the flexible sheet member, parallel to one another. Each fastening member comprises a metal sleeve and a piece of wood or fiberboards mounted in the sleeve. Each fastening member is adapted for receiving fasteners therein. The present invention also pertains to a kit for such an underlayment and to a method for assembling the same.

WO 2009/067814 A1

UNDERLAYMENT FOR HARDWOOD FLOORING AND COVERING

RELATED APPLICATION

The present application claims priority of United States provisional patent
5 application No. 60/990,645 filed on November 28, 2007, the specification of
which is incorporated herein by reference.

FIELD OF THE INVENTION

The present invention generally relates to an underlayment for a covering such
as hardwood flooring and to a kit for such underlayment. The present invention
10 also relates to a method of manufacturing an underlayment for hardwood flooring
and covering.

BACKGROUND OF THE INVENTION

Hardwood flooring is very popular for its durability and appearance. Further,
because hardwood boards have a typical thickness of 3/4 inch they may be
15 sanded on multiple occasions over its lifetime, it provides advantages over
engineered products such as laminate floor or veneers.

Hardwood flooring boards are generally provided with tongue and groove. This
configuration enables assembly of board to one another to define a floor. This
floor can be mounted on a subfloor in a floating configuration. With this particular
20 configuration, no fastener is used and the weight of the combined boards holds
them in place. However, because the wood tends to react with moisture over
time, cracks are more prone to appear than with floors permanently fixed to the
subfloor.

To permanently attach the hardwood flooring to a subfloor, boards can be either
25 fixed using nails or staples, driven through the tongue of boards at an angle of
roughly 45 degrees. Alternatively, hardwood flooring can be mounted with glue
where the subfloor is unsuitable for receiving nails or staples. This is the case, for
instance, with concrete subfloors.

Gluing hardwood floor however tends not to be a suitable solution for installing a hardwood floor over a concrete surface since hardwood floor manufacturers tend not to guarantee their product if such permanent installation is carried out. Customers therefore need to have some kind of floor underlayment installed prior to fastening hardwood flooring thereto.

One of the most common underlayment structure used over concrete surfaces consists in a vapor barrier or a rubber mat (e.g. Dura-son®) laid down over the concrete surface, which vapor barrier or rubber mat is further covered with a layer of plywood. The plywood layer has a typical thickness ranging from about 3/4 inch to 1 inch to avoid staples or nails used for fixing the hardwood flooring to strike through the plywood layer, hit the vapor barrier or the rubber mat and compromise their anti-moisture or soundproofing properties. In addition to be cost ineffective, the construction codes of some jurisdictions requires different building trades to install the vapor barrier, the plywood layer and the hardwood flooring, which may render the operation troublesome for contractors. Further, the soundproofing properties of such an underlayment structure tend not to be satisfactory, especially in multiplex residences such as condominiums and apartments.

Some other underlayment structures make use of boards made from sound absorbing material such as expanded polystyrene (EPS) disposed on a side-by-side arrangement to define a length. These structure further use wood or medium density fiberboard (MDF) lumbers that may, in some instance be profiled. The lumbers are placed in a side-by-side relationship, along the length of sound absorbing boards. Alternating lengths of sound absorbing boards and lumbers are placed over the floor to cover a specific area. The profile lumbers enable nailing or stapling the hardwood flooring therein. The construction of such underlayment structure tend to be time consuming and therefore uneconomical. Further, to enable stapling or nailing therein, these structures tend to require a minimal thickness of 1 inch. Such a thickness tends to be problematic for contractor since door sills or thresholds generally have a height or thickness of 5/8 inch. Therefore, contractors are required to raise all door sills to match the

thickness of the underlayment structure which contribute to increase the costs associated with hardwood flooring installation.

It would therefore be advantageous to be provided with an improved underlayment structure that overcomes at least one of the drawbacks associated with previous underlayment structures.

SUMMARY OF THE INVENTION

In order to address the above and other drawbacks, and in accordance with the present invention, there is disclosed an underlayment for hardwood flooring and covering.

10 In accordance with one embodiment of the present invention, there is provided an underlayment for fastening a floor thereon. The underlayment comprises a flexible sheet member having a bottom face contacting a horizontal surface, such as, a concrete surface, when the underlayment is laid down thereon and an opposed top face. The underlayment also comprises a plurality of elongated, spaced-apart fastening members. The fastening members are mounted parallel to one another on the top face of the sheet member, each pair of adjacent fastening members defining a space therebetween. The fastening members are adapted for receiving floor fasteners therein, where floor fasteners enable fastening the floor on the underlayment.

20 In one feature, the floor comprises hardwood flooring.

The embodiment described above is particularly advantageous since the installation of the underlayment and flooring is greatly simplified with respect to the one of prior art products. Indeed, the installation can advantageously be performed in a faster manner, thus providing a more cost-effective solution than the prior art solutions. Moreover, the modular aspect of the underlayment also eases transport thereof.

In another feature, the sheet member comprises a vapor barrier having a bottom face and a top face. In yet another feature, the sheet member further comprises a

layer of insulating material mounted to the top face of the vapor barrier, and preferably a layer of foam.

In a further feature, each fastening member comprises an elongated, generally channel-shaped sleeve made from a hard material, and preferably made from a metal. The fastening member also comprises an elongated piece of a softer material mounted in the sleeve. The softer material is preferably selected from a group consisting of wood, medium density fiberboard (MDF), high density fiberboard (HDF), plywood, particle board, oriented strand board (OSB), plastic and rubber.

In still a further feature, the underlayment comprises a plurality of insulating sheet members. Each insulating sheet member is sized and shaped for being mounted in one of the space defined between a pair of adjacent fastening members. Each insulating sheet member is further shaped and sized to enable the floor fasteners to be received in the fastening members when said floor is positioned on the underlayment. The insulating may be a rigid sheet member, and preferably a sheet of at least one of expanded polystyrene (EPS) and extruded polystyrene (XPS). Alternatively, the insulating sheet member can be a flexible sheet member, and preferably comprises a layer of foam.

In another feature, the underlayment has a thickness ranging from about 1/8 inch to about 3 inches, and preferably a thickness ranging from about 3/8 inch to about 2 inches, and more preferably a thickness ranging from about 5/8 inch to about 1 inch, and even more preferably a thickness of 5/8 inch.

This embodiment advantageously overcomes the time-consuming and uneconomical operation of raising all door sills to match the thickness of the underlayment, as it is the case with prior art underlayment solutions, thereby enhancing again the cost-effective aspect of the underlayment.

According to another embodiment of the present invention, there is also provided an underlayment for fastening a covering thereon. The underlayment comprises a flexible sheet member having a first face for covering a surface when the underlayment is laid down thereon and an opposed second face. The underlayment also comprises a plurality of elongated, spaced-apart fastening

members mounted parallel to one another on the second face of the flexible sheet member. Each pair of adjacent fastening members defines a space therebetween. The fastening members are adapted for receiving covering fasteners therein, where covering fasteners enable fastening the covering on the underlayment.

According to another embodiment, there is also provided an underlayment for installing a floor thereon, the underlayment comprising:

- a flexible sheet member having a bottom face for contacting a horizontal surface when the underlayment is laid thereon and an opposed top face;

- a layer of flexible and rollable insulating material mounted on the top face of the flexible sheet member, said layer of insulating material having a top face provided with a plurality of parallel and spaced-apart channel-shaped grooves spanning said layer widthwise;

- a plurality of elongated fastening members, each sized and shaped to fit in a corresponding one of said grooves, each fastening member comprising an elongated channel-shaped sleeve made from a hard material and an elongated piece of a material softer than said hard material, mounted in said sleeve; said elongated piece made of a softer material being adapted for receiving floor fasteners therein for fastening said floor to said fastening members.

According to another embodiment of the present invention, a kit for an underlayment for fastening a covering thereon is provided. The underlayment comprises a flexible sheet member having a first face for covering a surface when the underlayment is laid down thereon and an opposed second face. The kit further comprises a plurality of elongated fastening members. The fastening members are mountable spaced apart from and parallel to one another on the second face of the sheet member. When mounted, each pair of adjacent fastening members defines a space therebetween. The fastening members are adapted for receiving covering fasteners therein, where the covering fasteners enable fastening of the covering on the underlayment.

According to another embodiment, a kit is provided for installing a floor on a surface.

The kit comprises:

- a plurality of elongated membranes, each comprising:

- a flexible sheet member having a bottom face for contacting a horizontal surface and an opposed top face; and

- a layer of flexible and rollable insulating material mounted on the top face of the flexible sheet member, said layer of insulating material having a top face provided with a plurality of parallel and spaced-apart channel-shaped grooves spanning said layer widthwise;

- a plurality of elongated fastening members, each sized and shaped to fit in a corresponding one of said grooves, each fastening member comprising an elongated channel-shaped sleeve made from a hard material and an elongated piece of a material softer than said hard material, mounted in said sleeve; said elongated piece being made of a softer material adapted for receiving floor fasteners therein; and;

- a plurality of fasteners for fastening said floor to said fastening members.

According to yet another embodiment, a method for assembling an underlayment for hardwood flooring or covering is provided. The method comprises: providing a vapor barrier having a bottom face and an opposed top face; providing a layer of insulating material having a bottom face and a top face; providing a plurality of soundproofing sheet members, each sheet members having a bottom face and a top face; fixedly mounting the bottom face of the insulating material to the top face of the vapor barrier; and fixedly mounting the bottom face of the sheet members to the top face of the insulating material, where the sheet members are placed parallel to one another in a side-by-side relationship, each pair of adjacent sheet members being positioned to define a slot therebetween, the slot being adapted for receiving a fastening member therein.

In one feature, the method further comprises: providing an elongated sleeve made from a hard material; providing a piece of a softer material sized and shaped to be received in said sleeve; mounting the piece of softer material in the sleeve to provide the fastening member and mounting the fastening members in the slots.

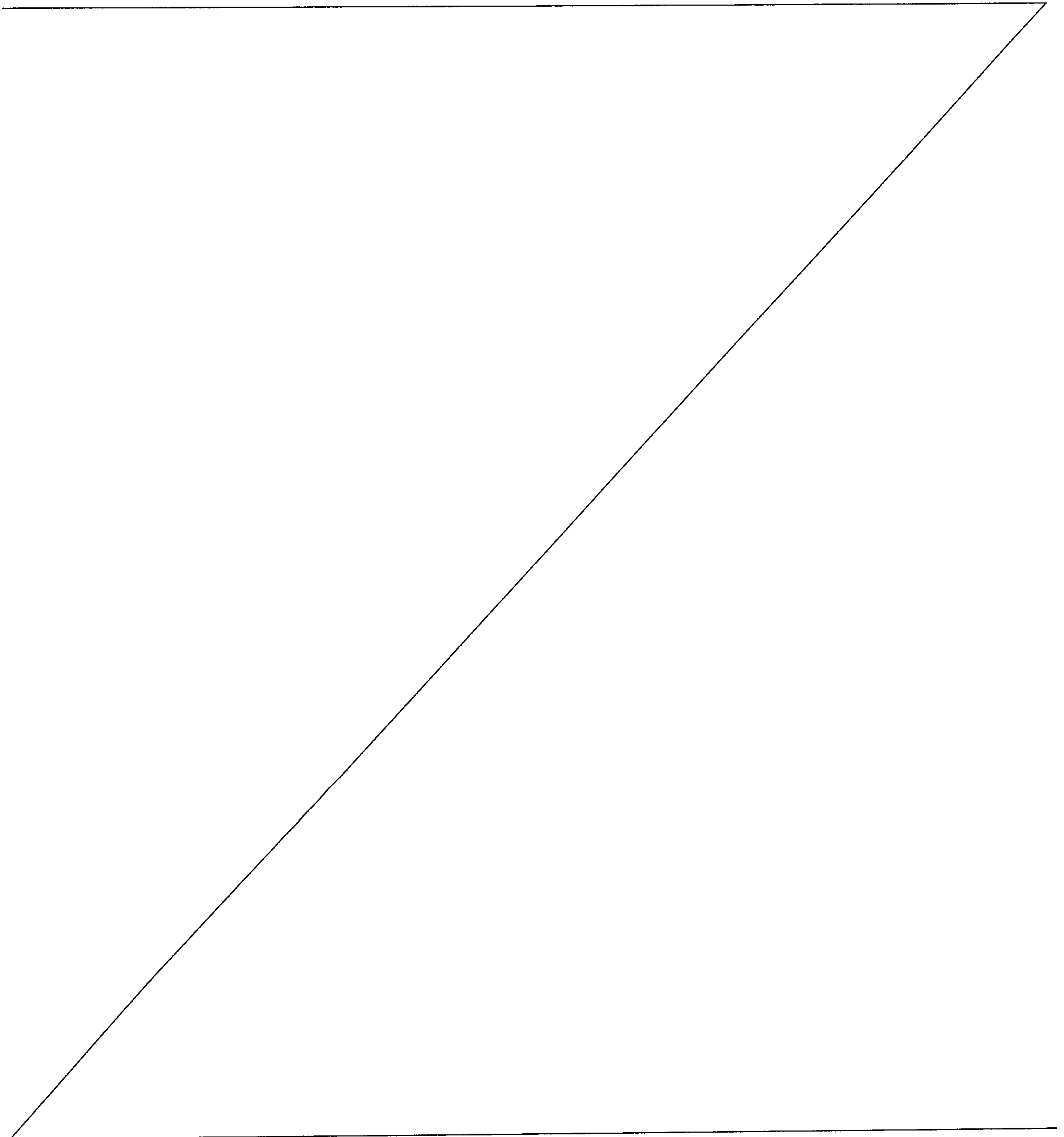

These and other objects, advantages and features of the present invention will become more apparent to those skilled in the art upon reading the details of the invention more fully set forth below.

BRIEF DESCRIPTION OF THE DRAWINGS

5 Having thus generally described the nature of the invention, reference will now be made to the accompanying drawings, showing by way of illustration an illustrative embodiment thereof, and in which:

FIG. 1 is a back left perspective view of an underlayment section according to one embodiment of the present invention;

10 FIG. 2 is a left side view of the underlayment section shown in FIG. 1;

FIG. 3 is a back left perspective view of the flexible sheet member of the underlayment section shown in FIG. 1;

FIG. 4 is an exploded view of the flexible sheet member shown in FIG. 3, showing the vapor barrier and the foam layer;

15 FIG. 5 is an enlarged perspective view of the fastening member of the underlayment section shown in FIG. 1;

FIG. 6 is a back left perspective view of the insulating sheet of the underlayment section shown in FIG. 1;

20 FIG. 7 is a back left perspective view of an underlayment section in accordance with another embodiment of the present invention;

FIG. 8 is a back left partially exploded perspective view of the underlayment section shown in FIG. 7, with a fastening member removed for showing a slot;

FIG. 9 is a left side view of the underlayment section shown in FIG. 7;

25 FIG. 10 is a back left perspective view of an underlayment section according to a further embodiment of the present invention;

FIG. 11 is a left side view of the underlayment section shown in FIG. 10;

FIG. 12 is a back left perspective view of an underlayment section according to yet a further embodiment of the present invention;

FIG. 13 is a left side view of the underlayment section shown in FIG. 12;

FIG. 14 is a back left elevation view of an underlayment section in accordance with another embodiment of the present invention;

FIG. 15 is a left side view of the underlayment section shown in FIG. 14;

FIG. 16 is a back left perspective view of an underlayment section according to yet another embodiment of the present invention;

FIG. 17 is a schematic representation of a plurality of underlayment sections installed on the floor of a room;

FIG. 18 is a left side view of the underlayment section shown in FIG. 1, with boards of hardwood flooring fastened thereto; and

FIG. 19 is a front side view of the underlayment section shown in FIG. 18, with boards of hardwood flooring fastened thereto.

15 **DETAILED DESCRIPTION**

The description which follows, and the embodiments described therein are provided by way of illustration of an example, or examples of particular embodiments of principles and aspects of the present invention. These examples are provided for the purpose of explanation and not of limitation, of those principles of the invention. In the description that follows, like parts are marked throughout the specification and the drawings with the same respective reference numerals.

It should also be noted that even if the illustrated embodiments and description thereof mainly show floors, the invention is also directed to and encompasses the mounting of other coverings such as walls or any vertical surfaces, as well as ceilings.

With reference to FIGS. 1 to 5, an underlayment section in accordance with one embodiment is shown, using the reference numeral 20. As it will become apparent below, the underlayment section 20 is advantageously adapted for being laid down on a generally horizontal surface (not shown) such as a floor or a subfloor. The underlayment section 20 allows mounting flooring that generally requires nailing or stapling while preventing nails or staples to reach such a horizontal surface. Therefore, the underlayment section 20 may be useful for installing hardwood flooring on horizontal surfaces that traditionally prevent nailing or stapling, such as concrete and metal floors. A person skilled in the art will appreciate that the underlayment section 20 could also be used on wood surfaces or other surface enabling direct stapling or nailing therein, for instance to level floor irregularities or to increase soundproofing characteristics thereof. Such increased soundproofing may be advantageous, for instance, in older apartment complexes where structural elements, such as floor joist and subfloors, were built from lumbers and wood, which structural elements do not provide sufficient sound insulation. It will further be appreciated by a person skilled in the art that the underlayment section 20 may also find use with flooring that typically does not require nailing or stapling such as, for instance, laminate flooring.

The underlayment 20 generally comprises a flexible sheet member 22 in contact with the horizontal surface when the underlayment 20 is installed, a plurality of space-apart fastening members 26a, 26b mounted to the sheet member 22 and a plurality of insulating sheets 28a-28c, also mounted to the flexible sheet member 22, on each side of the fastening members 26a, 26b.

With reference to FIGS. 3 and 4, the flexible sheet member 22 comprises a front end 30, a back end 32 and left and right side ends 34, 36. The sheet member also comprises a bottom face 38, adjacent to the floor surface on which the underlayment is installed, and an opposed top face 40, facing up, toward the flooring mounted on the underlayment 20. In one embodiment, the flexible sheet member 22 comprises a vapor barrier 42 having a bottom face 44 corresponding to the bottom face 38 of the sheet member 22 and an opposed top face 46. The vapor barrier 42 is preferably a polyethylene membrane having a front edge 48, a back edge 50 and left and right side edges 52, 54. A person skilled in the art will

however appreciate that other vapor barrier could fit the purpose of the invention and that such vapor barrier could comprise vapor barrier made from any material, and may comprise any plastic or foil sheet resisting the passage of moisture therethrough. In one embodiment, the vapor barrier 42 has a length (between the
5 front and back edges 48, 50) of 25 feet and a width (between the side edges 52, 54) of 4 feet 4 inches. The vapor barrier 42 could be sized differently without departing from the scope of the invention.

Mounted on the top face 46 of the vapor barrier 42 is a layer of foam 56, also having a bottom face 58 and a top face 60. In this embodiment, the bottom face
10 58 of the foam layer 56 is adjoining the top face 46 of the vapor barrier 42 and the top face 52 of the foam layer 56 corresponds to the top face 40 of the flexible sheet member 22. The foam layer 56 has a front edge 62, a back edge 64 and left and right side edges 66, 68. In one embodiment, the foam layer 56 has a
15 length of 25 feet (between the front and back edges 62 and 64) and a width (between the side edges 66 and 68) of 4 feet. It will thus be appreciated by a person skilled in the art that the vapor barrier 42 is sized slightly wider than the foam layer 48.

In one embodiment, the foam layer 48 and the vapor barrier 42 are glued to one another. In an alternate embodiment, the foam layer 48 could be laminated to the
20 vapor barrier 42. Once assembled, the front edges 48, 62, the back edges 50, 64 and the left edges 52, 66 of the vapor barrier 42 and of the foam layer 56, respectively, are aligned to one another. As such, a portion of the vapor barrier 42 protrudes from the right edge 68 of the foam layer 56, thereby defining a lip 70.

25 In one preferred embodiment, the lip 70 is integrally formed with the vapor barrier 42 and has a width adapted for receiving thereon a portion of an adjacent section of underlayment 20, thereby reducing circulation of air between the two adjoining underlayment sections. In this embodiment, the lip 70 has a width ranging from
30 about 1 inch to about 5 inches, and more preferably a width of about 4 inches. To further minimize air and moisture leaks between two adjacent underlayment sections, the lip 70 can be provided with a strip of two-sided adhesive tape 72. A first side of the two sided adhesive tape 72 is fixed along the lip 70, on the top

face thereof. The second side of the two sided adhesive tape covered with a protective membrane. Upon installation of a second, partially overlapping underlayment section 20, the protective membrane covering the second side of the tape 72 is peeled off to expose the adhesive. The second underlayment section is then partially laid down over the lip 70, therefore enabling the second side of the tape to adhere to the bottom face 38 of the adjacent flexible sheet member 42.

In one embodiment, the foam layer 56 has a thickness of about 1/8 inch and the vapor barrier 42 a thickness of about 1 mm or less. The thickness of the vapor barrier 42 being somewhat negligible, the sheet member 22 has an overall thickness of about 1/8 inch.

Referring to FIGS. 1 to 5, mounted on the top surface 40 of the sheet member 22 are the fastening members 26a, 26b. Since all fastening members 26a, 26b are similar, only fastening member 26a will be described. A person skilled in the art will appreciate that a similar description will also apply to fastening member 26b and to other fastening members having a similar configuration.

As shown in FIG. 5, the fastening member 26a comprises a generally channel-shaped sleeve 74 having a left end 76 and a right end 78. In one embodiment, the sleeve 74 is made from a hard material such as metal. Extending between the ends 76, 78 are a generally horizontal base wall 80 and a pair of spaced-apart side walls 82, 84, perpendicular to the base wall 80 and extending generally upright. On the top edge of each side wall 82, 84 is horizontally extending a top wall, 86, 88, respectively. The top walls 86, 88 are parallel to the base wall 80 and are spaced-apart from one another to define a top opening 90. The top opening 90 extends longitudinally between the left and right ends 76, 78 to provide access to a lumber 92 mounted in the sleeve 74, as it will become apparent below.

In one embodiment, the sleeve 74 has a length (between side ends 76, 78) of 4 feet, therefore corresponding to the width of the foam layer 56, and a height of 1/2 inch. In this embodiment, the sleeve 72 has a width (between the exterior faces of the side wall 82, 84) of about 2 inches.

Mounted in the sleeve 74 is the elongated piece or lumber 92. The lumber 92 is preferably made from a material capable of receiving nails or staples therethrough. Such material comprises, for instance, wood, medium density fiberboard (MDF), high density fiberboard (HDF), plywood, particle board, oriented strand board (OSB) or plastic. A person skilled in the art will appreciate that any material capable of receiving nails or staples therethrough and preventing unwanted removal thereof could be used. The lumber 92 is sized and shaped to fit in the sleeve 74. As such, the lumber 92 preferably has a length (between the side ends 76, 78) of 4 feet, a width of 1 7/8 inch and a thickness of 3/8 inch. The lumber 92 is preferably maintained in the sleeve 74 by frictional engagement. Alternatively, the lumber 92 could be glued in the sleeve or maintained loose.

As it will be appreciated by a person skilled in the art, a portion of the lumber 92 mounted in the sleeve 74 remains exposed through the opening 90, along the length of the fastening member 26a. As such, the opening 90 enables nails or staples to access the lumber 92 to fasten flooring on the underlayment 20, as it will be best described below. While in this embodiment the fastening member 26 comprises the sleeve 74 and the lumber 92, one may opt for using a fastening member comprising only a piece of softer material or lumber. Such a fastening member would therefore not be provided with a sleeve of harder material.

In one embodiment, the fastening member 26a is glued on the top face 52 of the foam layer 56, the left and right ends 76, 78 of the fastening member 26a being aligned with the left and right edges 66, 68 of the foam layer 56. Therefore, in this embodiment, the fastening member 26a extends parallel to the front and back edges 30, 32 of the sheet member 22. As it will become apparent below, one may choose not to glue or otherwise fix the fastening member 26 to the sheet member 22. In such an embodiment, the fastening members 26a, 26b could simply be laid down on the top face 52 of the foam layer 56.

Returning to FIGS. 1 and 2, each underlayment section 20 comprises multiple fastening members 26a, 26b. While on these figures only two fastening members 26a and 26b are shown, it will be understood that an underlayment section 20 may comprise more than two fastening members. In one embodiment, the

fastening members 26a, 26b are spaced-apart from and parallel to one another. The fastening members 26a, 26b are preferably mounted to the sheet member 22 at 12-inch intervals (e.g. from center of fastening member 26a to center of fastening member 26b). In this embodiment, a space having a width of 10 inches
5 is provided between each pair of adjacent fastening member 26a, 26b. A person skilled in the art will understand that the space between each fastening member 26a, 26b could be different without departing from the scope of the invention.

On each side of the fastening members 26a, 26b are mounted the sheets of insulating material 28a-28c. The sheets 28a-28c of insulating material are
10 preferably sheets of a flexible acoustic and thermal insulation material such as foam or fiberglass insulation. In alternate embodiments, the sheets 28a-28c could be made from a rigid insulating material such as expanded polystyrene (EPS) (e.g. Insul-Board™) or extruded polystyrene (XPS) (e.g. Styrofoam™). It will be understood by a person skilled in the art that sheets 28a-28c could be made from
15 any insulating material, either flexible or rigid.

Since sheets 28a-28c have a similar configuration, only sheet 28b will be described. A person skilled in the art will understand that a similar description also applies to sheet 28a and 28c. Referring to FIG. 6 and also to FIGS. 1 and 5, the sheet 28b has a front edge 96 adjacent to fastening members 26a, a back
20 edge 98, adjacent to fastening member 26b, a left edge 100 and a right edge 102. The sheet 28b also has a bottom face 104 and a top face 106. The bottom face 104 of the sheet 28b is mounted to the top face 40 of the sheet member 22. The top face 106 is facing up, toward the flooring installed on the underlayment 20. Between the bottom and top faces 104 and 106 is define a thickness. In one
25 embodiment, the thickness of the sheet 28b corresponds to the thickness of the fastening members 26a, 26b and is preferably 1/2 inch.

The sheet 28 is preferably sized and shaped to fit between a pair of fastening member 26a, 26b. As such, each sheet 28a-28c has preferably a length of 4 feet (between the left and right edges 100,102) and a width of 10 inches (between the
30 front and back edges 96, 98). The left and right edges 100, 102 of the sheet 28b are aligned with the left and right edges 66, 68 of the foam layer 58.

Once assembled, the sheet member 22, the fastening members 26a, 26b and the sheets 28a-28c define the thickness of the underlayment 20. In one embodiment, the underlayment has a thickness of 5/8 inch defined by the sheet member 22 (1/8 inch) and the insulating sheets 28a-28c (1/2 inch) or the fastening member 26a, 26b (1/2 inch). A person skilled in the art will however appreciate that the dimensions of the underlayment section and of its components (e.g. sheet member, fastening member; etc) can vary and be adapted to fit the needs of customers.

Now turning to FIGS. 7 to 9, an underlayment section according to another embodiment of the invention will be described, using reference numeral 200. In this embodiment, the underlayment section 200 comprises a sheet member 202, a layer of insulating material 204 mounted on the sheet member 202 and a plurality of fastening members 206a-206c.

The sheet member 202 slightly differs from the sheet member 22 of underlayment section 20 in that sheet member 202 only comprises a vapor barrier 208. In other words, the sheet member 202 does not comprise a foam layer, such as foam layer 58 of sheet member 22. The sheet member 202 comprises a front end 210, a back end 212 and left and right side ends 214, 216. The sheet member 202 also comprises a bottom face 218, adjacent to the floor surface on which the underlayment section 200 is installed, and a top face 220, facing up, toward the flooring mounted on the underlayment 200. The vapor barrier 208 is preferably a polyethylene membrane but it will be appreciated that other vapor barrier could fit the purpose of the invention. In one embodiment, the sheet member 200 has a length (between the front and back ends 210 and 212) of 25 feet and a width (between the side ends 214, 216) of 4 feet 4 inches.

Mounted on the top face 220 of sheet member 202 is the layer of insulating material 204. The layer 204 has a bottom face 222 and a top face 224. In this embodiment, the bottom face 222 of the layer 204 is adjoining the top face 220 of sheet member 202. The layer 204 has a front edge 226, a back edge 228 and left and right side edges 230, 232. In one embodiment, the layer 204 has a length of 25 feet (between the front and back edges 226 and 228) and a width (between the side edges 230 and 232) of 4 feet. It will thus be appreciated by a person

skilled in the art that the layer 204 is sized slightly narrower than the sheet member 202. In this embodiment, the layer 204 has a thickness of 5/8 inch.

The layer 204 is provided with a plurality of channel-shaped slots or grooves 234a-234c adapted for receiving therein a corresponding plurality of fastening members 206a, 206b (best shown in FIG. 8). Each of the slots 234a-234c is carved out from the foam layer 204 using CNC equipment or the like and is sized and shaped to slip fit a fastening member 206a or 206b therein. In one embodiment, each slot 234a or 234b extends from the left side edge 230 to the right side edge 232 of the layer 204, and has a width of about 2 inches and a depth of 1/2 inch. It will thus be understood that at the bottom of each slot 234a-234c, the layer 204 has a thickness of 1/8 inch, which is similar to the thickness of the foam layer 56 of underlayment section 20.

Fastening members 206a-206c have the general configuration of fastening members 26a and 26b of underlayment section 20. As such, fastening members 206a-206c each comprises a generally channel-shaped sleeve 236 made from a hard material in which is mounted a softer elongated piece or lumber 238. Similarly to lumber 92 of underlayment section 20, the lumber 238 is made of a material capable of receiving nails or staples therethrough. In one embodiment, the sleeve 236 has a length of 4 feet, therefore corresponding to the width of the layer 204, and a height of 1/2 inch, which corresponds to the depth of the slots 234a-234c. In this embodiment, the fastening members 206a-206b have a width of 2 inches.

In one embodiment, fastening members 206a-206c are mounted to the layer 204 by simply sliding or placing a fastening member 206a-206c in a corresponding slot 234a-234c. Therefore, gluing or attaching the fastening members 206a, 206b is not required. In some instances, frictional engagement of the fastening member 206a or 206b by the side walls of the slot 234a or 234b is possible, but is not required. Therefore, the configuration of the underlayment 200 enables providing a user with a kit comprising, on one side, the sheet member 202 to which is attached the foam layer 204 and, on the other side, the fastening members 206a-206c mountable in the slots 234a-234b. The assembly of the fastening members 206a-206c to the sheet member 202 and the foam layer 204

can be performed on the construction site. This particular configuration may thus facilitate transport and adjustment of the size of the underlayment section 200 to the room in which it is installed, as it will become apparent below. A person skilled in the art will however appreciate that the fastening members 206a, 206b
5 could be glued or otherwise fastened to the layer 204.

In a further alternate embodiment of the present invention, an underlayment section 300 is shown in FIGS. 10 to 13. In this embodiment, the underlayment section comprises a sheet member 302 on which is mounted a plurality of fastening assemblies 304a-304d.

10 Similarly to sheet member 202 of underlayment section 200, sheet member 302 only comprises a vapor barrier 308. The vapor barrier is preferably a polyethylene membrane. The vapor barrier has a bottom face 310 adjacent to the horizontal surface upon installation and an opposed top face 312. The sheet member 302 has the general shape and size of the sheet member 202.

15 Each fastening assembly 304a, 304d comprises a fastening member 314 similar to fastening member 26a and an underneath foam layer 316. The foam layer 316 has a length corresponding to the length of the fastening member 314 and has a bottom face 318 adjacent to the top face 312 of the vapor barrier 308 and a top face 322 adjoining the bottom face 320 of the fastening member 314. The
20 underneath layer 316 is aimed to reduce noise attributable to contact between the fastening member 314 and the horizontal surface, also known as drum effect. In one embodiment, the foam layer 316 has a thickness of 1/8 inch and the fastening member 314 has a thickness of 1/2 inch.

As best shown in FIGS. 12 and 13, the section 300 may further comprise
25 insulating sheets 306a-306c. The presence of such insulating sheets 306a-306c may however not be required, as best shown in FIG. 10 and 11.

Because foam is known to be moisture impermeable, the presence of a vapor barrier such as polyethylene film may not be required in all circumstances. As such, FIGS. 14 and 15 show an underlayment section 400 according to another
30 embodiment of the present invention. In this embodiment, the underlayment section is provided with a flexible sheet member 402 comprising only a foam

layer 404. Mounted on the foam layer 404 is a plurality of fastening member 406a-406c having the generally configuration of fastening members 26a-26b. It will be appreciated by one skilled in the art that layer or sheets of insulating material could be mounted between the fastening members 406a-406d (not shown).

In a further alternate embodiment shown in FIG. 16, an underlayment section 450 could be provided with a plurality of sheet members 452a-452b spaced-apart from one another in a parallel relationship and a plurality of fastening members 454a-454d. In this embodiment, the fastening members 454a-454b are mounted on the sheet members 452a-452b, perpendicular thereto. Such a configuration of underlayment section could be used, for instance, where moisture movement does not require to be controlled. As it will be appreciated by a person skilled in the art, layers or sheet of insulating material could be mounted between the fastening members 454a-454d.

Because they are provided with flexible sheet members 22, 202, 302, 402 and 452, the underlayments 20, 200, 300, 400 and 450, respectively, can be rolled to facilitate transport thereof. Where the underlayment is provided with rigid sheet of insulating material, the underlayment section may be folded, such as, for instance, in an accordion configuration, to facilitate transport thereof. Alternatively, the sheets of rigid insulating material can be dissociated from the sheet member and the fastening members for transport and placed on the underlayment section onsite.

Having described configurations of underlayment according to various embodiments, the method of installation of such underlayments will now be described with reference to FIGS. 17 to 19. In this example, two sections of underlayment 20 (i.e. 20a and 20b) are installed on the concrete floor of a room 500.

The contractor receives the underlayment 20, which is preferably packed as a roll of 100 sq. ft. (i.e. 25 feet long and 4 feet wide). The roll of underlayment 20 may be packed, for instance, in a box or maintain as a roll using straps or the like. It will be appreciated by a person skilled in the art that the used of rigid insulating

sheets may not permit rolling the underlayment. As such, the underlayment may be folded in an accordion configuration to facilitate transport thereof, as described above.

5 The contractor takes the first underlayment 20a out of its box or release the straps and places the front end 30 along a first wall 502 (i.e. the front wall of the room) and the left end 34 along a second wall 504, perpendicular to the front wall 502 (i.e. the left wall of the room). The contractor then unrolls the first underlayment 20a until he reaches the back wall 506 of the room (i.e. the wall opposed to the front wall), ensuring that the front and left side ends 30 and 34 of
10 the underlayment 20 remain in position along their respective walls 502 and 504, respectively.

When required, the contractor cuts underlayment 20 to fit the length (i.e. the distance between the front and back walls 502, 504) and the configuration of the room (i.e. the angles of the walls). More specifically, the contractor cuts through
15 the insulating sheet 28a-28c, the foam layer 56 and the vapor barrier 42 using, for instance a utility knife, a saw or the like.

In one embodiment, the underlayment section 20a is maintained on the horizontal surface by gravity. In an alternate embodiment, the underlayment section 20a could be glued or otherwise permanently fastened to the horizontal surface.

20 Once the first section of underlayment 20a has been properly installed, the contractor proceeds to install the second underlayment section 20b. Similarly to the first underlayment section 20a, the contractor positions the front end 30 of the section 20b along the front wall 502. The underlayment section 20b is further positioned such that the left side end 34 thereof will adjoin the right side end 36 of
25 the section 20a and overlap the lip 70 thereof. Further, the second section 20b is positioned such that fastening members 26 of the second section 20b are longitudinally aligned with corresponding fastening members of the first underlayment section 26a.

30 The protective membrane of the two-sided tape of section 20a is removed to expose the adhesive and the section 20b is unrolled. The bottom face 38 of the second section 20b then contacts the adhesive of the two-sided tape. A pressure

can be provided to ensure proper adhesion of the second section 20b to the first section 20a. Similarly to section 20a, section 20b is cut to a desired length.

Further underlayment sections (not shown) are then added side by side, until the full surface of the room 500 is covered, after which flooring can be mounted to the underlayment section. Where the length of an underlayment section (e.g. 20a) is not sufficient to cover the full length of the room, additional underlayment sections (e.g. 20c) can be added at the back end 32 thereof. In this situation, the front end 30 of the additional underlayment section (e.g. 20c) is positioned for adjoining the back end 32 of the first underlayment section (e.g. 20a) and the left end 34 along the second wall 504. Since no lip is provided on the front end 30 of the underlayment sections 20c or the back end 32 the first underlayment section 20a, the joint between those underlayment sections can be sealed using insulating tape such as Tuck-tape®.

In an alternate embodiment where underlayment 200 is used instead of underlayment 20, the sheet member 202 of a first underlayment section 200a is unrolled, cut to a desired length and laid down on the floor of the room. The sheet members 202 of other underlayment sections are then placed beside the first sheet member 202, until the floor area has been covered. In this embodiment, each slot of an underlayment section 200 (e.g. slot 234a underlayment section 200a shown in FIG. 8) is longitudinally aligned with a corresponding slot on another section (e.g. slot 234a underlayment section 200b).

Once the floor is covered by sheet members, the contractor then turn to install the fastening members 206a-206d. To do so, the contractor places one fastening member 206a-206d in each of the slots 234a. Because the slots of multiple underlayments are aligned, the fastening members could extend beyond the side ends of one section. For instance, one fastening member could have a length corresponding to the width of 1.5 underlayment section. In such an embodiment, three underlayment section placed side-by-side would be provided with two fastening member per corresponding slot.

Turning again to FIGS. 18 and 19, tongue and groove hardwood boards 600a-600c fastened on underlayment 20 are shown. The boards 600a-600c are

mounted perpendicularly to the fastening members 26a, 26b. As such, a single hardwood board (e.g. 600a) will be fastened in multiple fastening members (e.g. simultaneously to 26a and 26b), as best shown in FIG. 18, and a same fastening member (e.g. 26a) will be used to fasten multiple boards (e.g. 600a-600c, as best shown in FIG. 19). Briefly, a first hardwood board is placed along the side wall 504, perpendicular to fastening members 26a-26b. A fastening tool containing fasteners such as staple is then aligned with fastening member 26a. The use of such tool and fastener is known in the art. The tool is then actuated and fasteners 602a-604c come through the board 600a and the lumber 92 of the fastening member 26a, the lumber 92 providing anchor to such fastener 602a-604c. Where the length of the fastener 602a-604c exceeds the combined thickness of the hardwood board 600a and of the lumber 92, the base portion 80 of the metal sleeve 74 causes the one end of the fastener to curve upon impact, thereby increasing the strength of the fastening provided by the fastening member 26. A second board 600b is then placed adjacent to the first board 600a, the tongue of the first board 600a engaging the groove of the second board 600b. The second board 600b is then fastened to the fastening members 26a-26b as described above. Additional boards are added on the underlayment 20 until the room has been completely covered.

CLAIMS

1. An underlayment for installing a floor thereon, the underlayment comprising:
 - a flexible sheet member having a bottom face for contacting a horizontal surface when the underlayment is laid thereon and an opposed top face;
 - a layer of flexible and rollable insulating material mounted on the top face of the flexible sheet member, said layer of insulating material having a top face provided with a plurality of parallel and spaced-apart channel-shaped grooves spanning said layer widthwise;
 - a plurality of elongated fastening members, each sized and shaped to fit in a corresponding one of said grooves, each fastening member comprising an elongated channel-shaped sleeve made from a hard material and an elongated piece of a material softer than said hard material, mounted in said sleeve; said elongated piece made of a softer material being adapted for receiving floor fasteners therein for fastening said floor to said fastening members.
2. An underlayment according to claim 1, wherein each of said sleeves has a generally U-shaped cross-section with a base wall and a pair of spaced-apart side walls extending perpendicular to the base wall.
3. An underlayment according to claim 2, comprising a foam layer underneath the base wall of each of said sleeves.
4. An underlayment according to claim 3, wherein said foam layer has a length corresponding to a length of the sleeve.
5. An underlayment according to any one of claims 2 to 4, wherein the side walls of each of said sleeves comprises a top edge provided with an inward flange.
6. An underlayment according to any one of claims 1 to 5, wherein the flexible sheet member comprises a vapor barrier.
7. An underlayment according to any one of claims 1 to 6, wherein the floor comprises hardwood flooring.

8. An underlayment according to any one of claims 1 to 7, wherein the insulating material comprises foam.
9. An underlayment according to any one of claims 1 to 8, wherein said hard material comprises a metal.
10. An underlayment according to any one of claims 1 to 9, wherein said softer material is wood, medium density fiberboard, high density fiberboard, plywood, particle board, oriented strand board, plastic or rubber.
11. An underlayment according to any one of claims 1 to 10, wherein said softer material is wood.
12. An underlayment according to any one of claims 1 to 11, wherein the fasteners are at least one of screws, nails and staples.
13. An underlayment according to any one of claims 1 to 12, wherein said fasteners have a length exceeding a combined thickness of the underlayment and floor.
14. An underlayment according to claim 13, the thickness of the underlayment ranges from about 1/8 inch to about 3 inches.
15. An underlayment according to claim 14, wherein said thickness ranges from about 3/8 inch to about 2 inches.
16. An underlayment according to 15, wherein said thickness ranges from about 5/8 inch to about 1 inches.
17. An underlayment according to any one of claims 1 to 16, wherein the layer of insulating material is laminated to the flexible sheet member.
18. A kit for installing a floor on a surface, the kit comprising:
 - a plurality of elongated membranes, each comprising:
 - a flexible sheet member having a bottom face for contacting a horizontal surface and an opposed top face; and

a layer of flexible and rollable insulating material mounted on the top face of the flexible sheet member, said layer of insulating material having a top face provided with a plurality of parallel and spaced-apart channel-shaped grooves spanning said layer widthwise;

- a plurality of elongated fastening members, each sized and shaped to fit in a corresponding one of said grooves, each fastening member comprising an elongated channel-shaped sleeve made from a hard material and an elongated piece of a material softer than said hard material, mounted in said sleeve; said elongated piece being made of a softer material adapted for receiving floor fasteners therein; and;

- a plurality of fasteners for fastening said floor to said fastening members.

19. A method for installing a floor on a surface, the method comprising:

(a) providing rolls of the plurality of elongated membranes as defined in claim 18;

(b) covering said surface by unrolling the membranes thereon in a side by side relationship and by lining up the grooves of adjacent membranes;

(c) inserting the plurality of elongated fastening members as defined in claim 17 into the grooves so as to obtain an underlayment;

(d) installing the floor on the underlayment;

(e) fastening the floor to the fastening members using fasteners.

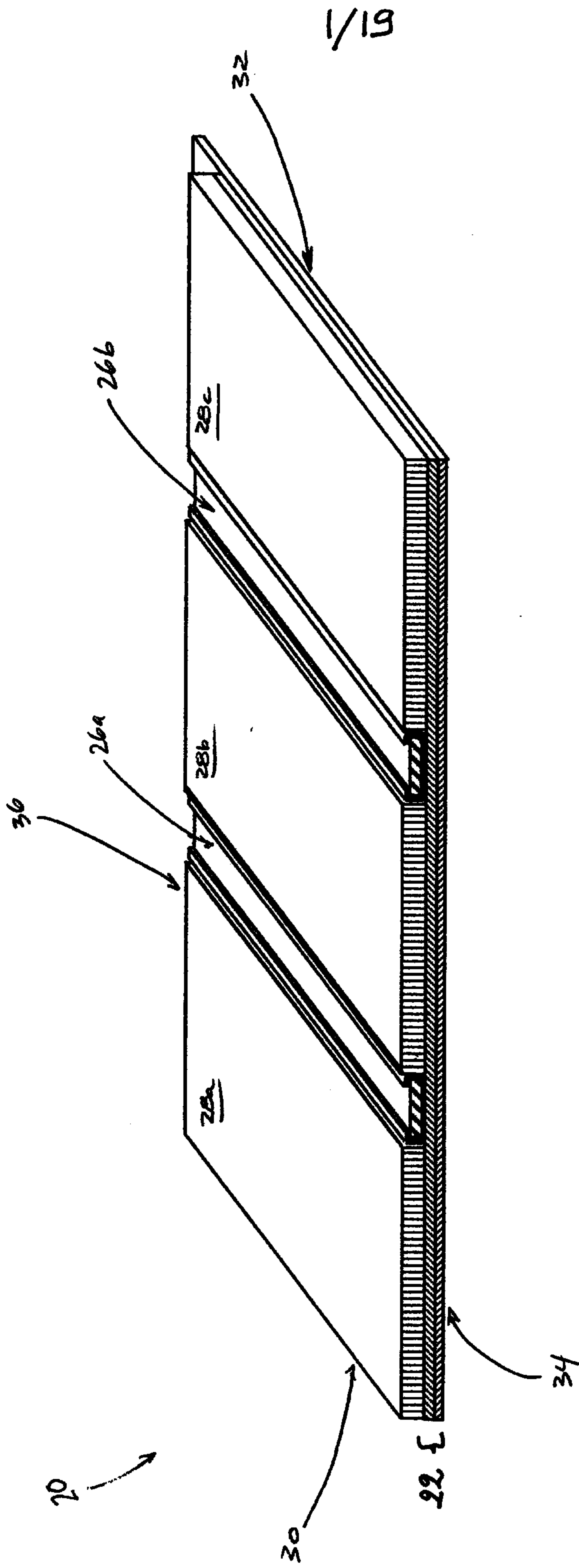

FIG. 1

2/19

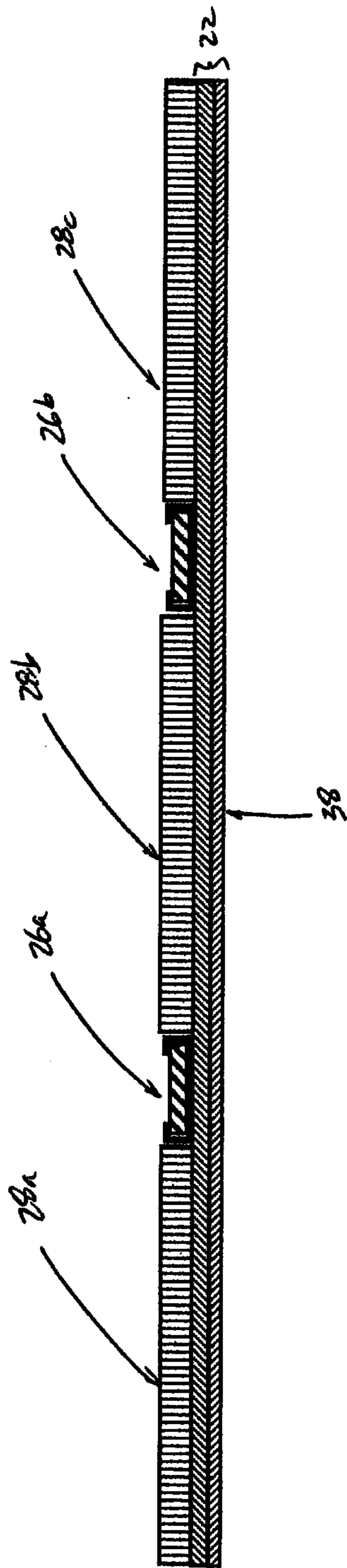

FIG. 2

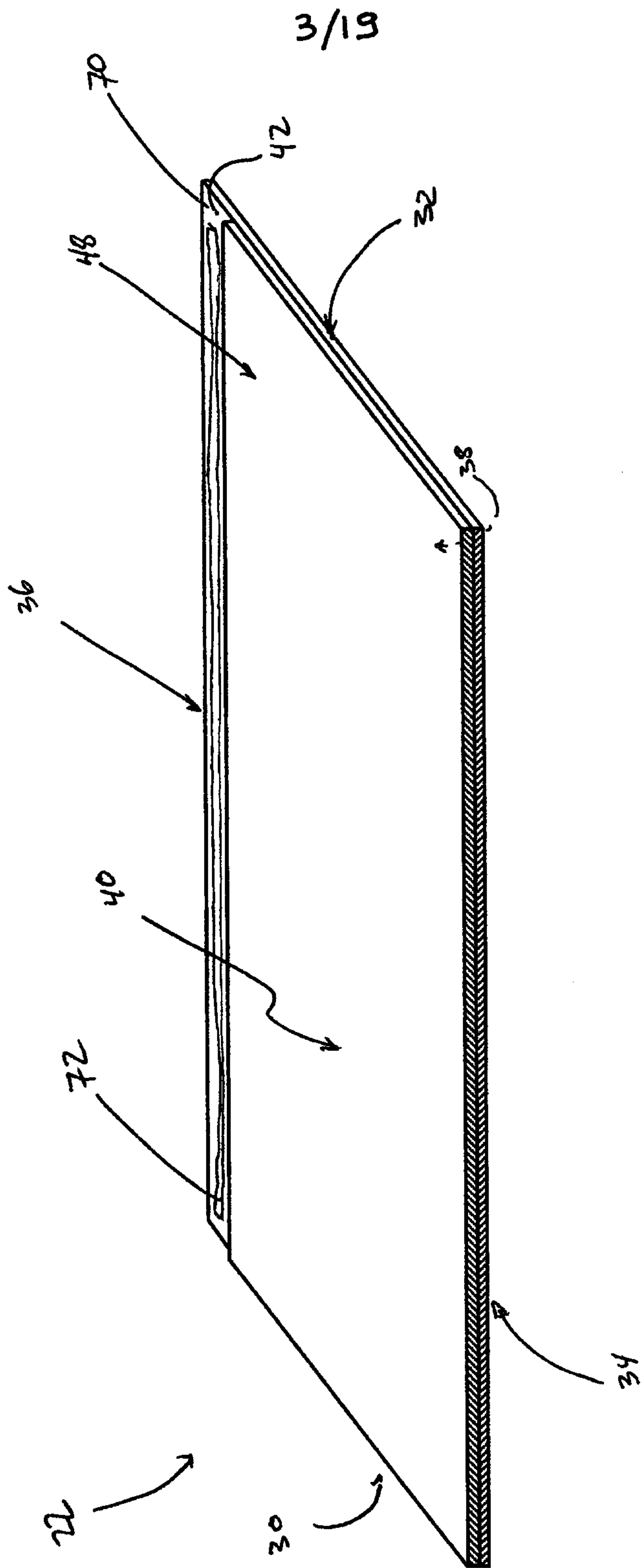

FIG. 3

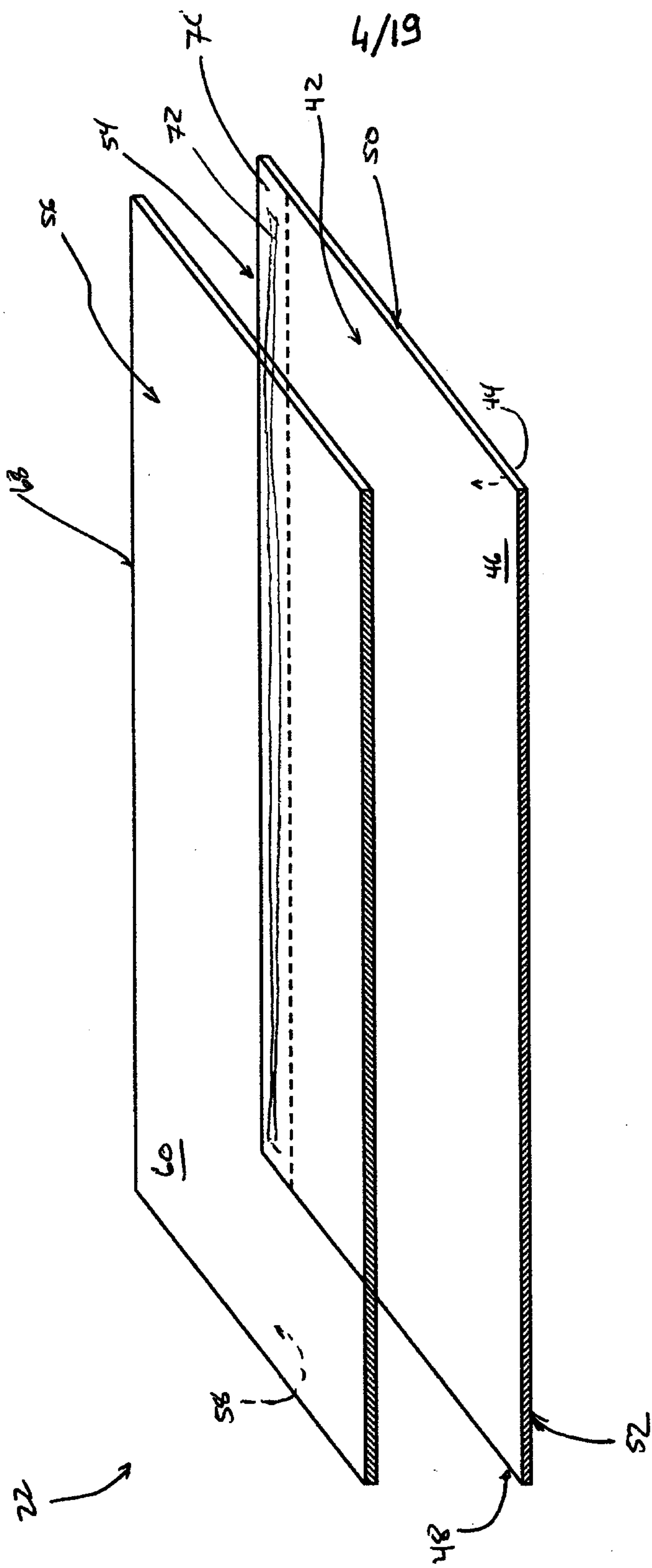

FIG. 4

5/19

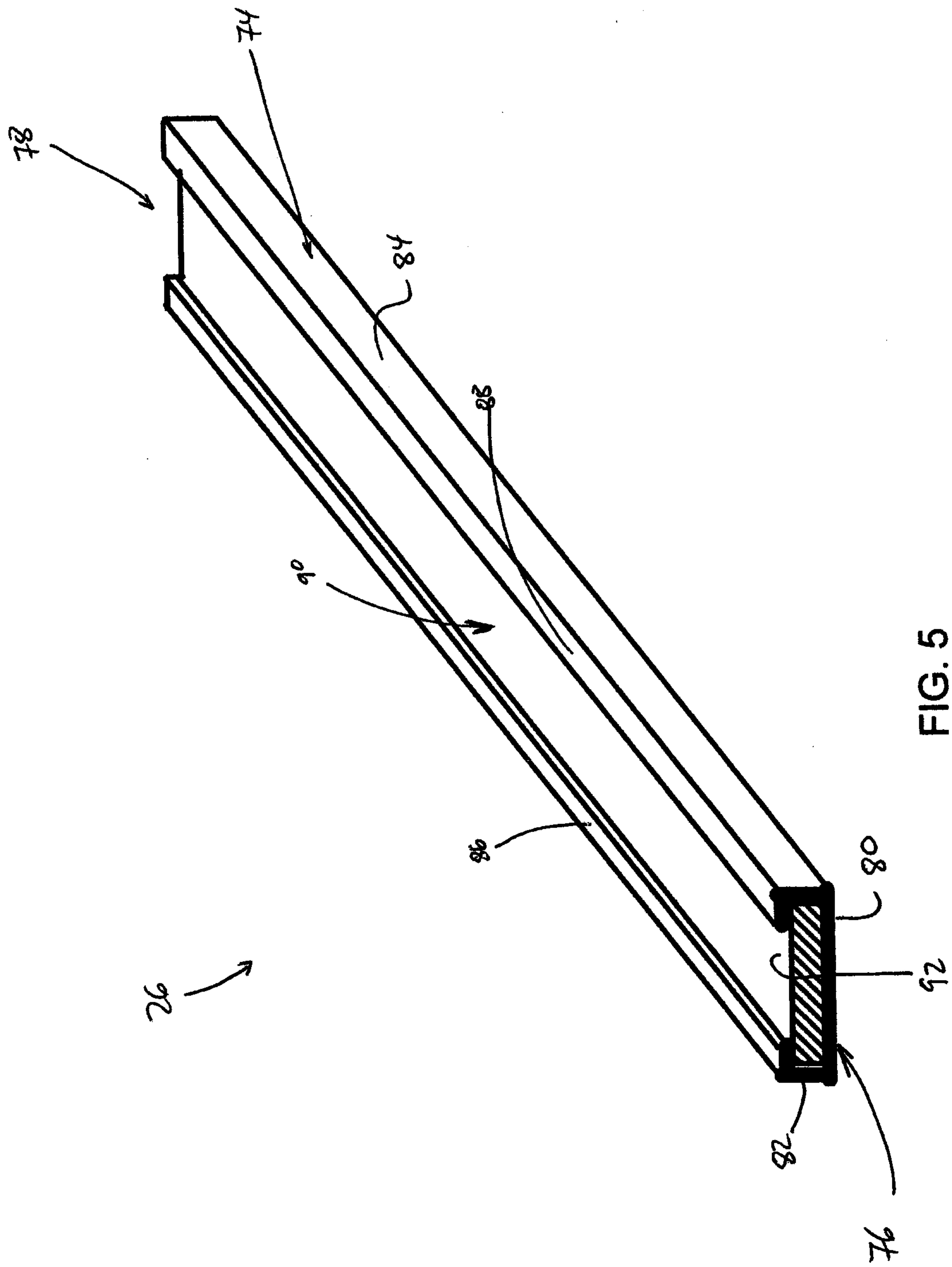

FIG. 5

6/19

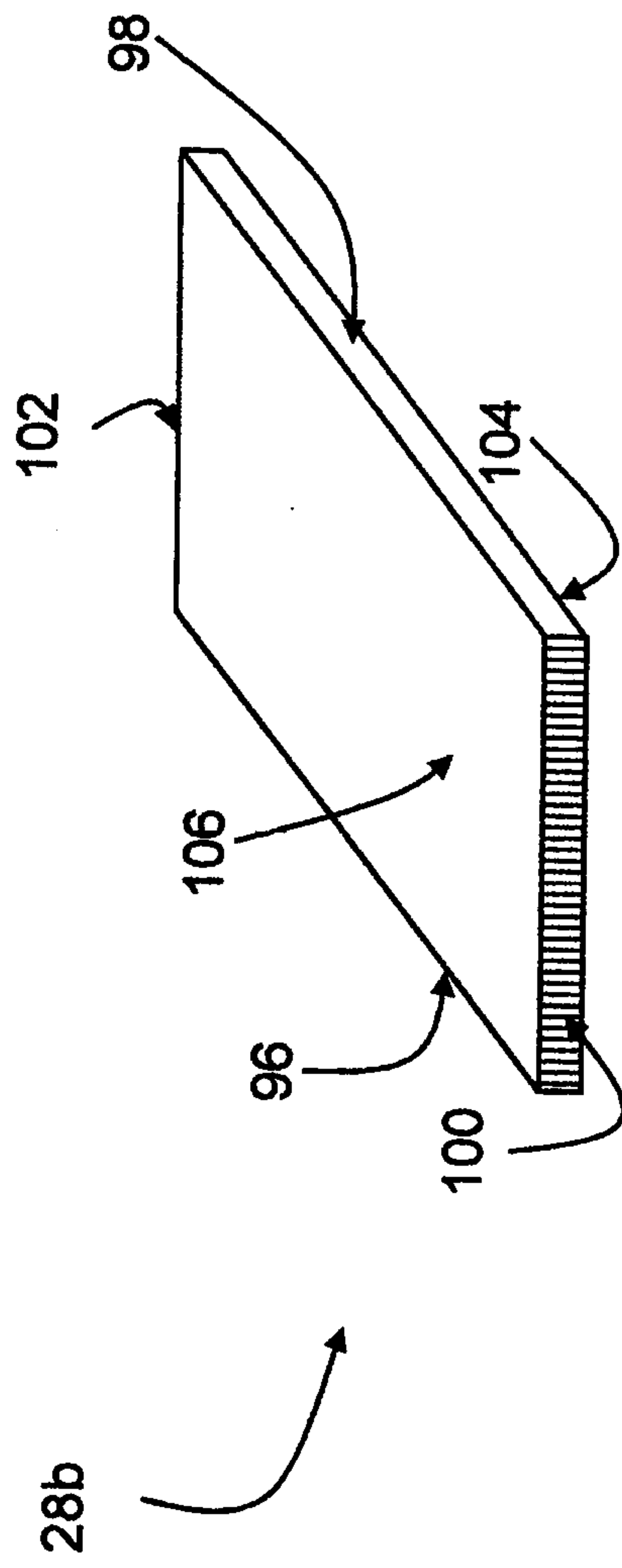

FIG. 6

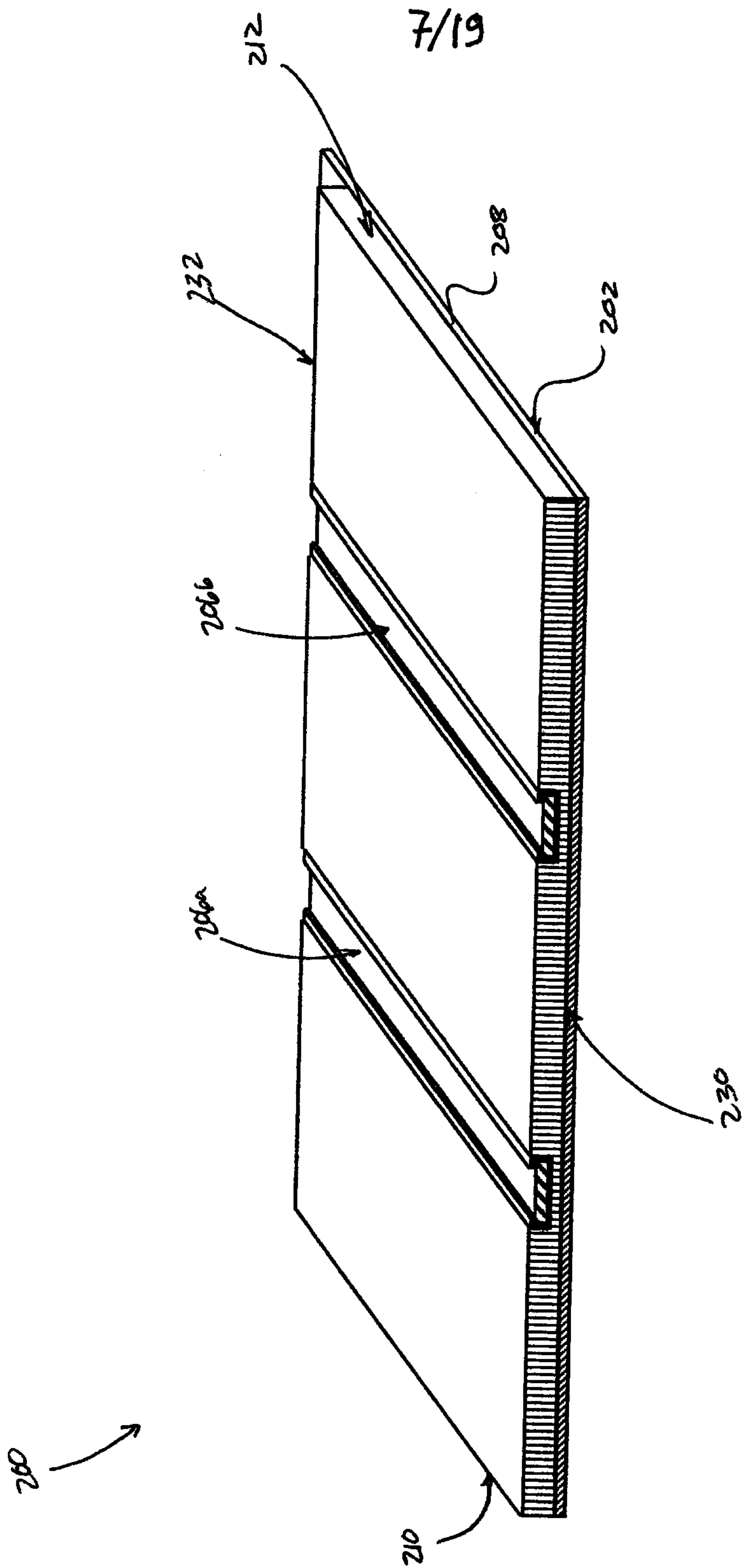

FIG. 7

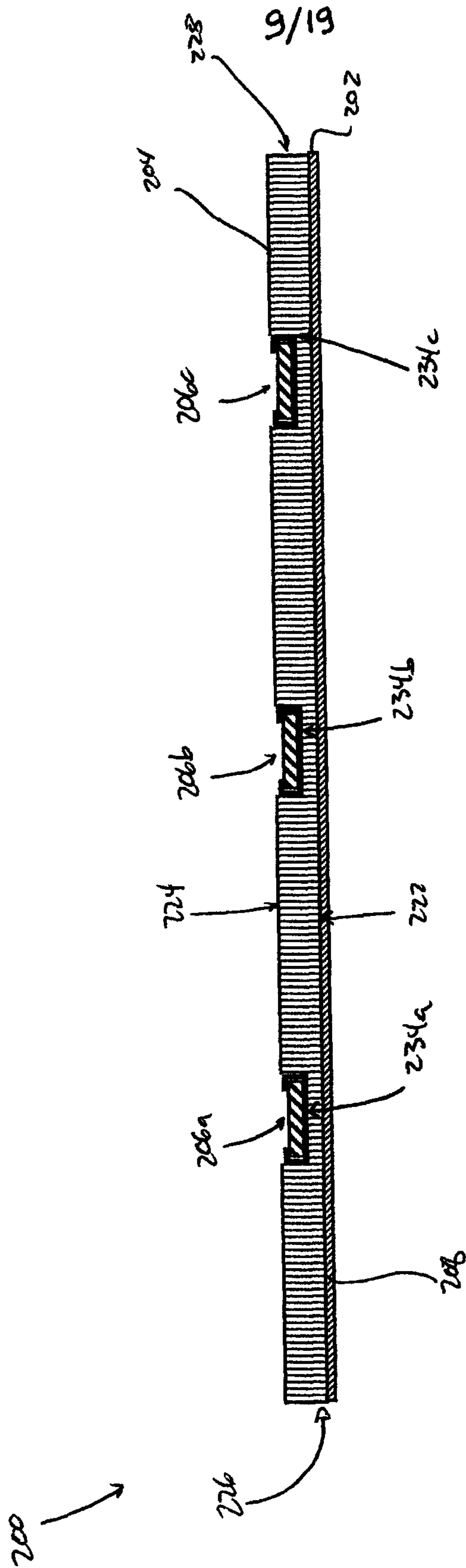

FIG. 9

10/19

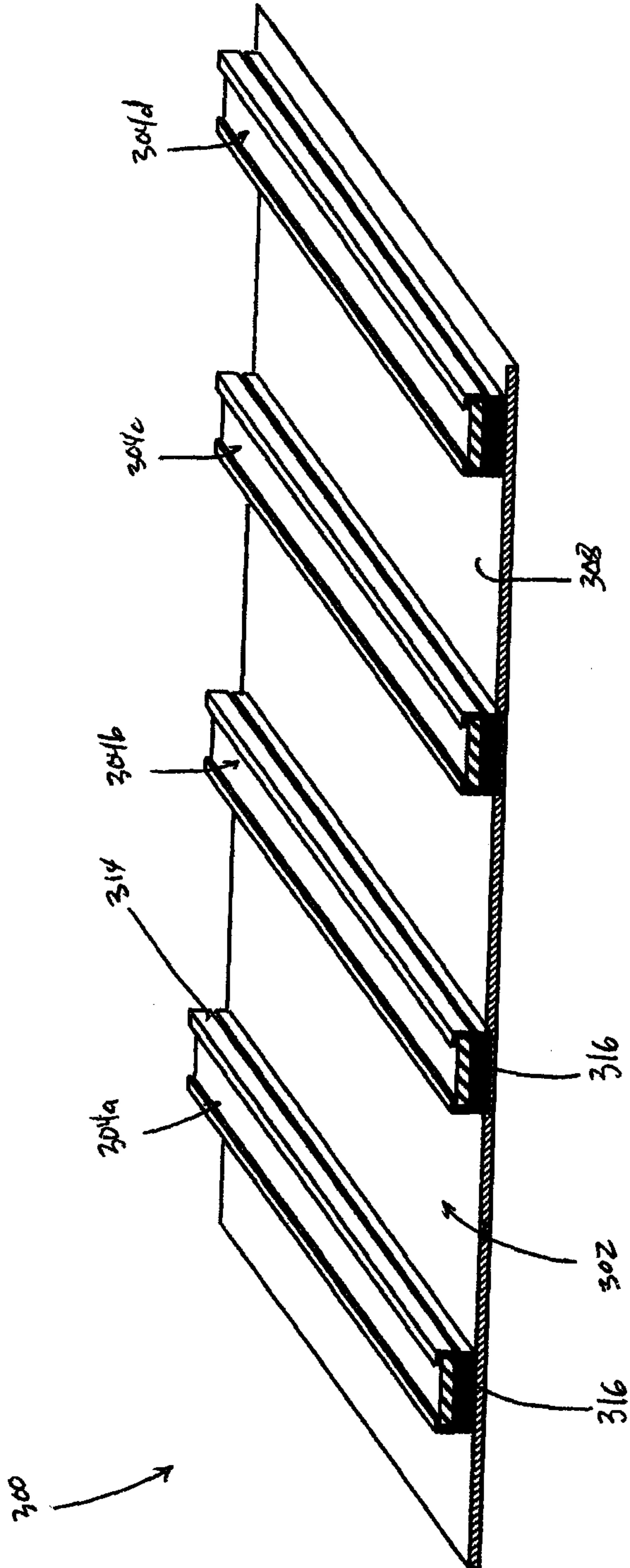

FIG. 10

240 →

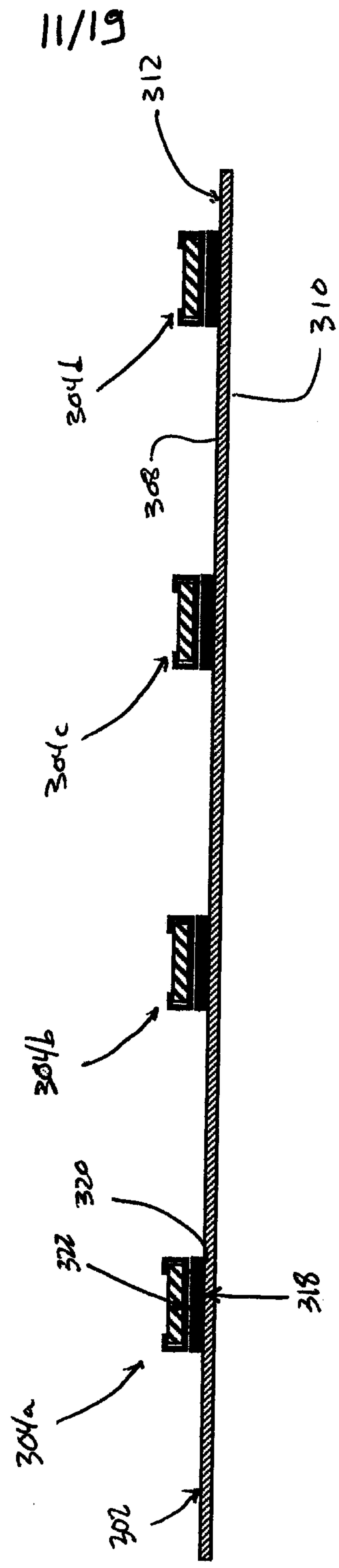

FIG. 11

12/19

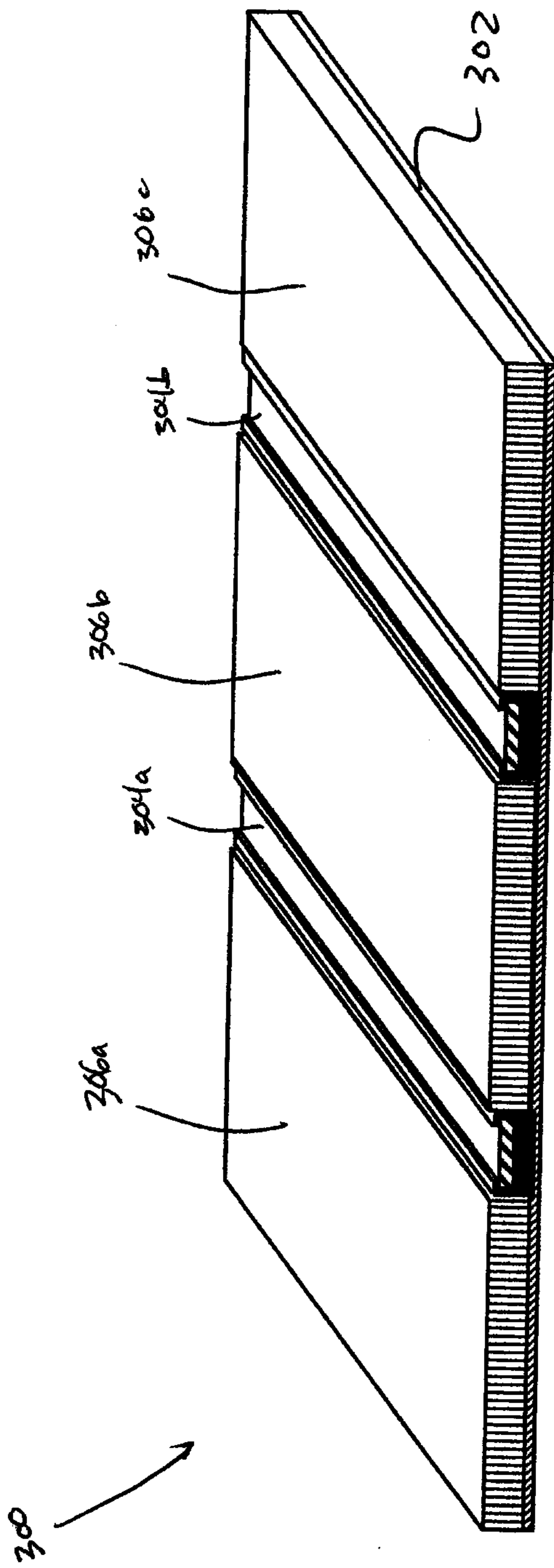

FIG. 12

13/19

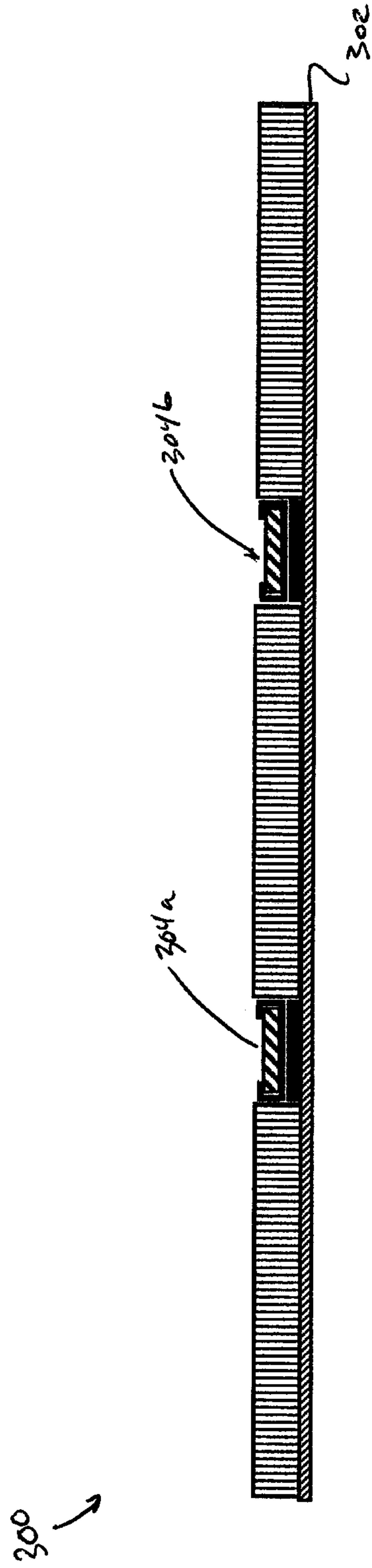

FIG. 13

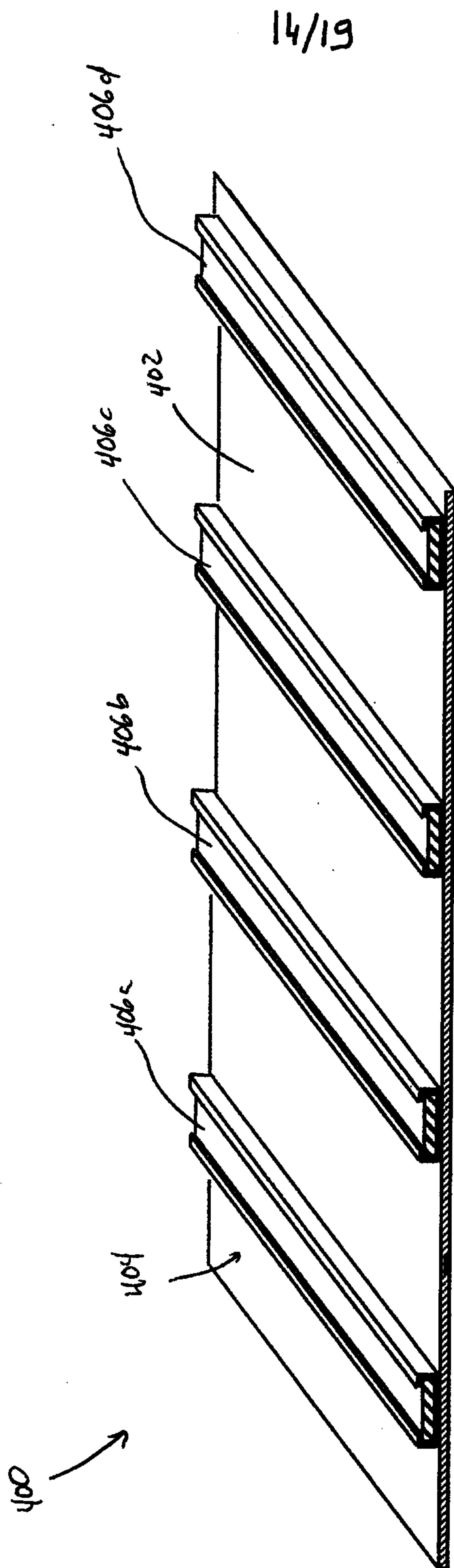

FIG. 14

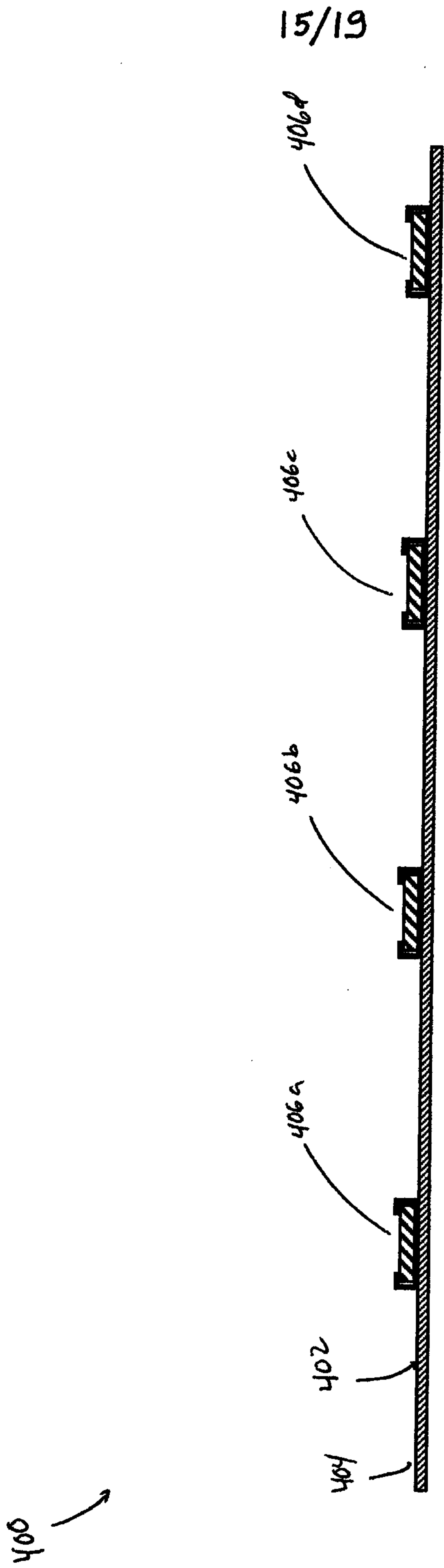

FIG. 15

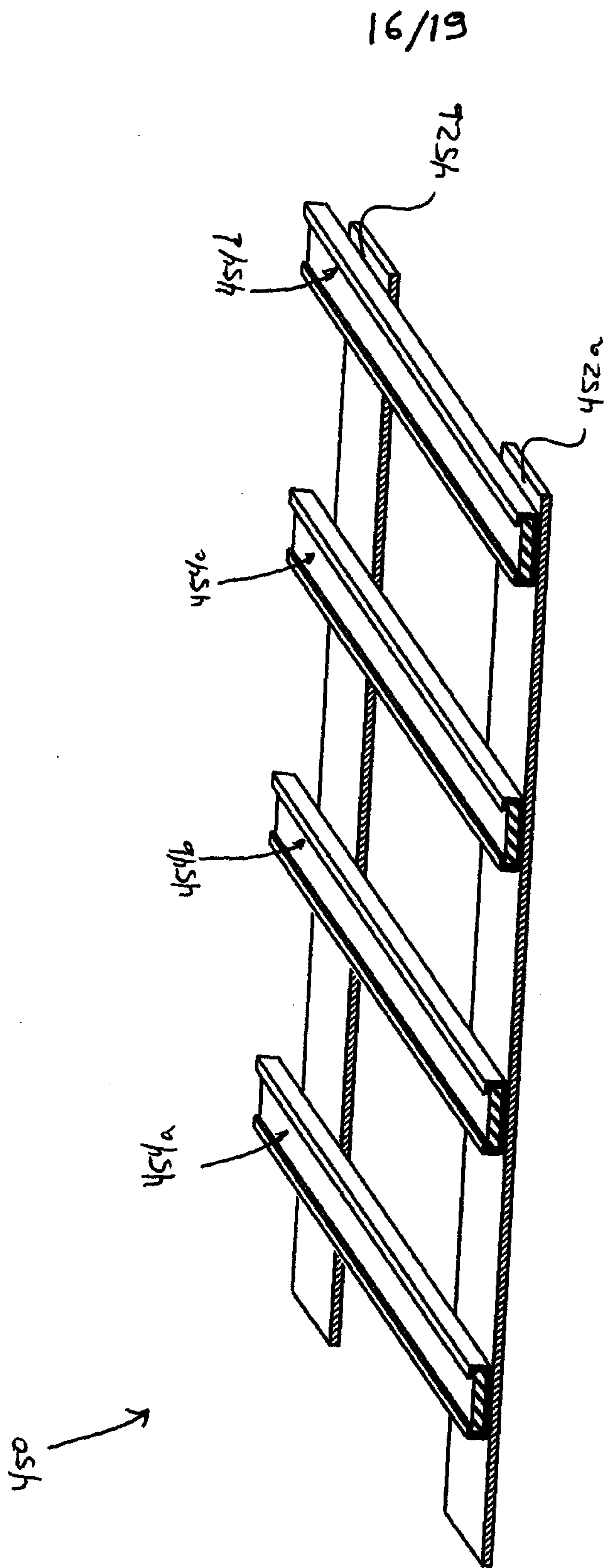

FIG. 16

17/19

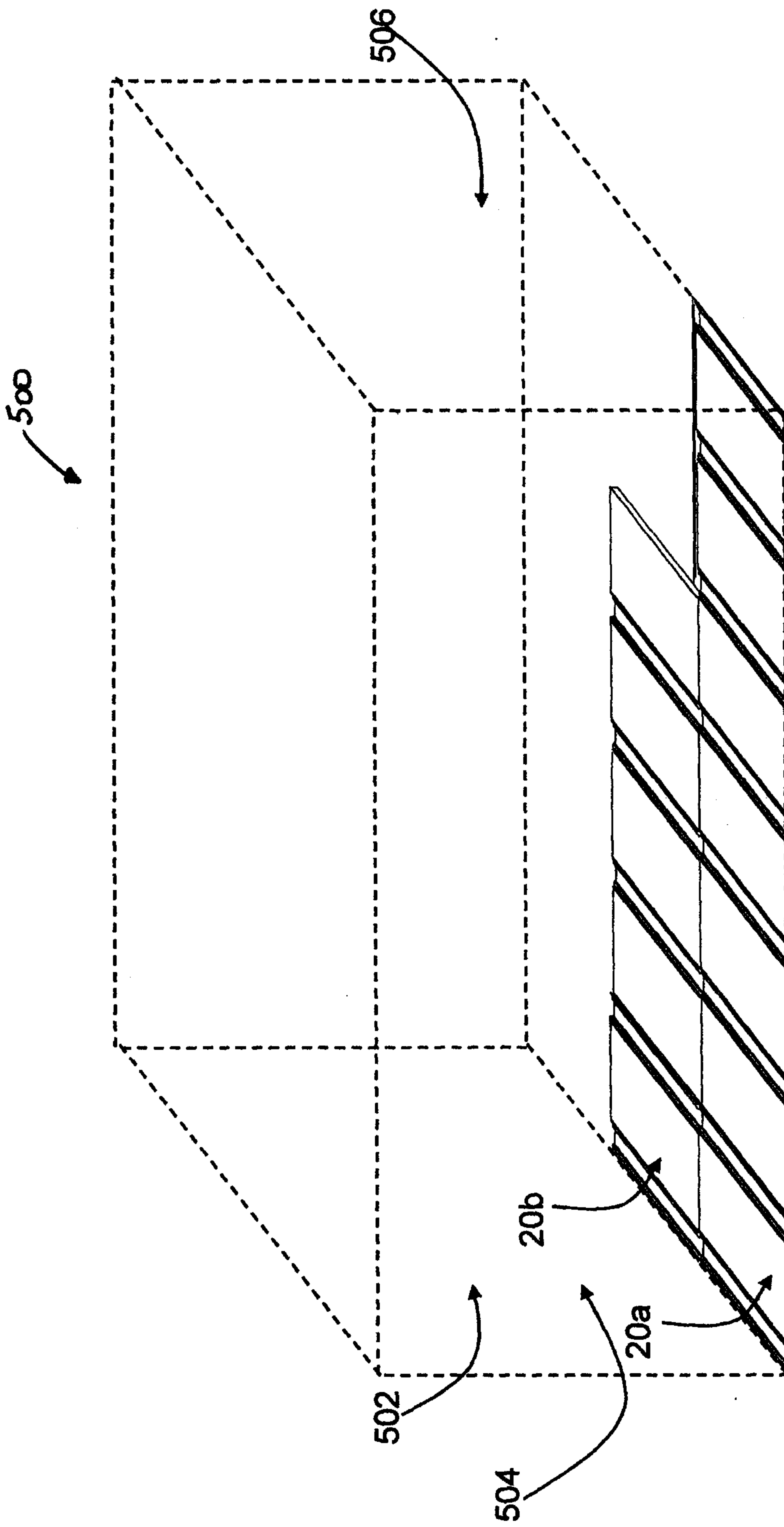

FIG. 17

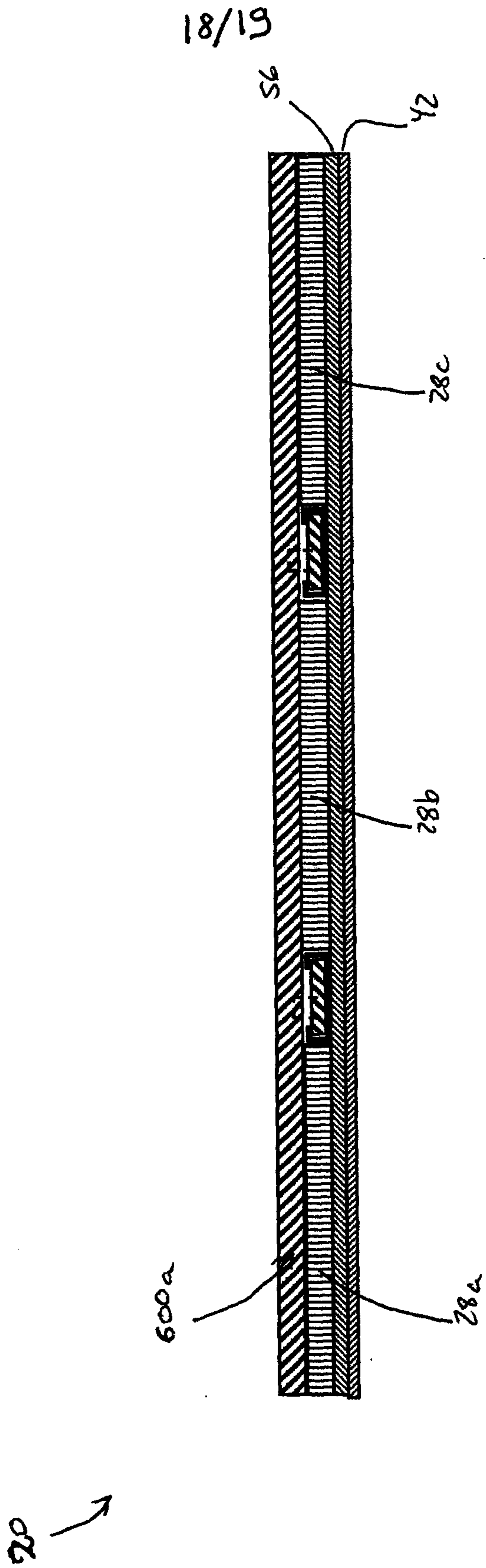

FIG. 18

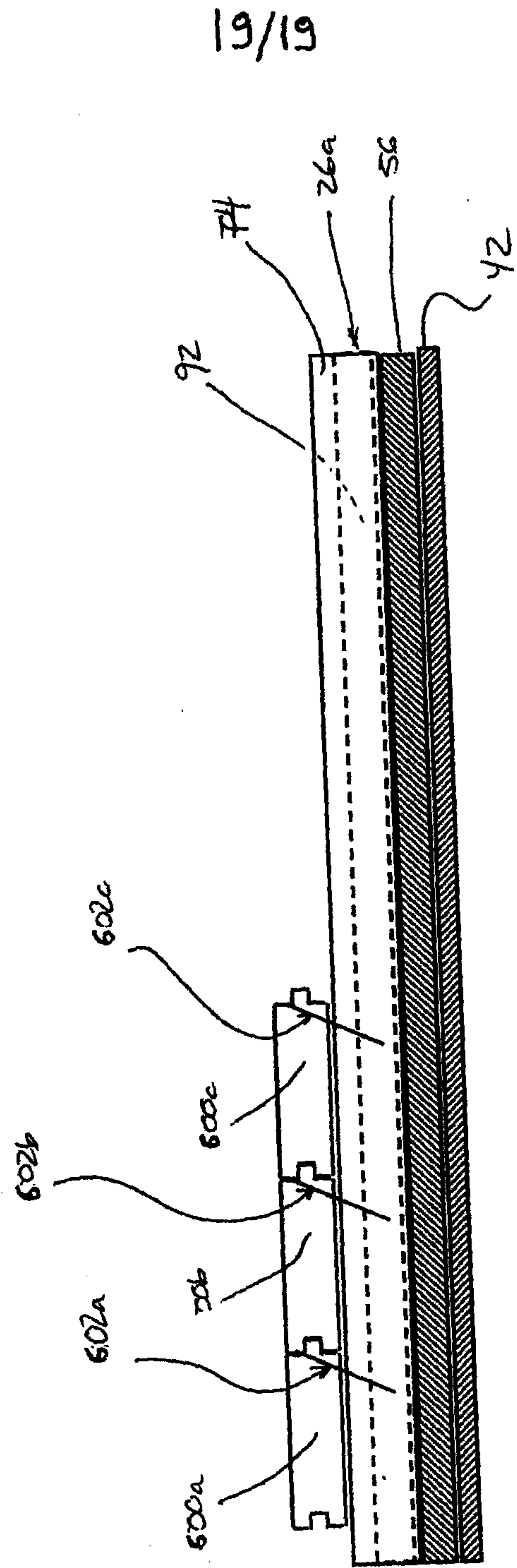

FIG. 19

