



US011141318B2

(12) **United States Patent**
Pigg et al.

(10) **Patent No.:** **US 11,141,318 B2**
(45) **Date of Patent:** ***Oct. 12, 2021**

(54) **WOUND DRESSING WITH ADHESIVE MARGIN**

(71) Applicant: **KCI USA, Inc.**, San Antonio, TX (US)

(72) Inventors: **William Pigg**, Elvington (GB);
Michelle Delbono, Earby (GB); **Sally Stephens**, Skipton (GB)

(73) Assignee: **KCI USA, INC.**, San Antonio, TX (US)

(*) Notice: Subject to any disclaimer, the term of this patent is extended or adjusted under 35 U.S.C. 154(b) by 875 days.

This patent is subject to a terminal disclaimer.

(21) Appl. No.: **15/659,486**

(22) Filed: **Jul. 25, 2017**

(65) **Prior Publication Data**

US 2018/0021180 A1 Jan. 25, 2018

Related U.S. Application Data

(63) Continuation of application No. 14/653,760, filed as application No. PCT/IB2013/060862 on Dec. 12, 2013, now Pat. No. 10,271,995.

(30) **Foreign Application Priority Data**

Dec. 18, 2012 (GB) 1222770

(51) **Int. Cl.**

A61F 13/02 (2006.01)

A61F 13/15 (2006.01)

(52) **U.S. Cl.**

CPC **A61F 13/0263** (2013.01); **A61F 13/0203** (2013.01); **A61F 13/0206** (2013.01);

(Continued)

(58) **Field of Classification Search**

CPC **A61F 13/0203**; **A61F 13/0206**; **A61F 13/0246**; **A61F 13/025**; **A61F 13/0253**;

(Continued)

(56) **References Cited**

U.S. PATENT DOCUMENTS

1,355,846 A 10/1920 Rannells
1,944,834 A * 1/1934 Bennett, Jr. A61F 13/023
428/139

(Continued)

FOREIGN PATENT DOCUMENTS

AU 550575 B2 3/1986
AU 745271 B2 3/2002

(Continued)

OTHER PUBLICATIONS

Louis C. Argenta, MD and Michael J. Morykwas, PhD; Vacuum-Assisted Closure: A New Method for Wound Control and Treatment: Clinical Experience; *Annals of Plastic Surgery*.

(Continued)

Primary Examiner — Bradley H Philips

(74) *Attorney, Agent, or Firm* — Foley & Lardner LLP

(57) **ABSTRACT**

A wound dressing comprising: a backing sheet; a layer of pressure-sensitive adhesive on the backing sheet; an island of absorbent material having smaller area than the backing sheet and applied onto a central region of the backing sheet so as to leave a margin of adhesive-coated backing sheet around the absorbent material, and an apertured wound facing layer applied over the absorbent material and adhered to the backing sheet around said island by said pressure-sensitive adhesive, wherein the apertured wound facing layer comprises an apertured substrate having a coating of a silicone gel on the wound facing surface thereof, the open area of the apertured wound facing layer is from about 5% to about 75%, and the apertured wound facing layer comprises apertures having an open area of from about 2 mm² to about 100 mm².

27 Claims, 5 Drawing Sheets

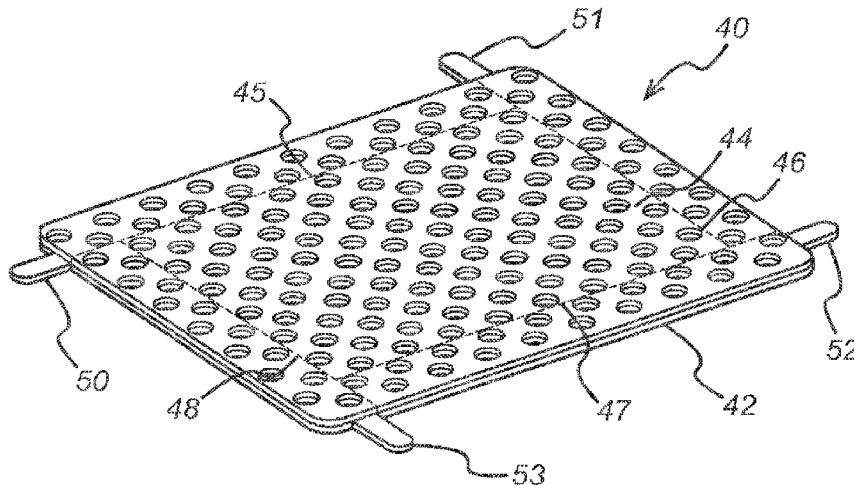

- (52) **U.S. Cl.**
 CPC *A61F 13/0246* (2013.01); *A61F 13/0253*
 (2013.01); *A61F 13/0289* (2013.01); *A61F*
13/15707 (2013.01); *A61F 13/025* (2013.01);
A61F 2013/15715 (2013.01)

- (58) **Field of Classification Search**
 CPC *A61F 13/0263*; *A61F 13/0289*; *A61F*
13/15707; *A61F 2013/15715*; *A61F*
13/0259-0266
 See application file for complete search history.

(56) **References Cited**

U.S. PATENT DOCUMENTS

2,547,758 A	4/1951	Keeling	4,710,165 A	12/1987	McNeil et al.
2,632,443 A	3/1953	Leshner	4,715,857 A	12/1987	Juhasz et al.
2,682,873 A	7/1954	Evans et al.	4,733,659 A	3/1988	Edenbaum et al.
2,910,763 A	11/1959	Lauterbach	4,743,232 A	5/1988	Kruger
2,969,057 A	1/1961	Simmons	4,753,230 A	6/1988	Carus et al.
3,066,672 A	12/1962	Crosby, Jr. et al.	4,758,220 A	7/1988	Sundblom et al.
3,172,808 A	3/1965	Baumann et al.	4,787,888 A	11/1988	Fox
3,367,332 A	2/1968	Groves	4,826,494 A	5/1989	Richmond et al.
3,376,868 A	4/1968	Mondiadis	4,832,008 A	5/1989	Gilman
3,520,300 A	7/1970	Flower, Jr.	4,838,883 A	6/1989	Matsuura
3,568,675 A	3/1971	Harvey	4,840,187 A	6/1989	Brazier
3,648,692 A	3/1972	Wheeler	4,848,364 A	7/1989	Bosman
3,682,180 A	8/1972	McFarlane	4,863,449 A	9/1989	Therriault et al.
3,742,952 A	7/1973	Magers et al.	4,871,611 A	10/1989	LeBel
3,774,611 A	11/1973	Tussey et al.	4,872,450 A	10/1989	Austad
3,777,016 A	12/1973	Gilbert	4,878,901 A	11/1989	Sachse
3,779,243 A	12/1973	Tussey et al.	4,897,081 A	1/1990	Poirier et al.
3,826,254 A	7/1974	Mellor	4,906,233 A	3/1990	Moriuchi et al.
3,852,823 A	12/1974	Jones	4,906,240 A	3/1990	Reed et al.
3,967,624 A	7/1976	Milnamow	4,919,654 A	4/1990	Kalt
3,983,297 A	9/1976	Ono et al.	4,930,997 A	6/1990	Bennett
4,080,970 A	3/1978	Miller	4,941,882 A	7/1990	Ward et al.
4,096,853 A	6/1978	Weigand	4,953,565 A	9/1990	Tachibana et al.
4,139,004 A	2/1979	Gonzalez, Jr.	4,961,493 A	10/1990	Kaihatsu
4,141,361 A	2/1979	Snyder	4,969,880 A	11/1990	Zamierowski
4,163,822 A	8/1979	Walter	4,981,474 A	1/1991	Bopp et al.
4,165,748 A	8/1979	Johnson	4,985,019 A	1/1991	Michelson
4,184,510 A	1/1980	Murry et al.	4,995,382 A	2/1991	Lang et al.
4,233,969 A	11/1980	Lock et al.	4,996,128 A	2/1991	Aldecoa et al.
4,245,630 A	1/1981	Lloyd et al.	5,010,883 A	4/1991	Rawlings et al.
4,256,109 A	3/1981	Nichols	5,018,515 A	5/1991	Gilman
4,261,363 A	4/1981	Russo	5,037,397 A	8/1991	Kalt et al.
4,275,721 A	6/1981	Olson	5,086,170 A	2/1992	Luheshi et al.
4,284,079 A	8/1981	Adair	5,092,323 A	3/1992	Riedel et al.
4,297,995 A	11/1981	Golub	5,092,858 A	3/1992	Benson et al.
4,333,468 A	6/1982	Geist	5,100,396 A	3/1992	Zamierowski
4,360,015 A	11/1982	Mayer	5,112,323 A	5/1992	Winkler et al.
4,373,519 A	2/1983	Errede et al.	5,134,994 A	8/1992	Say
4,382,441 A	5/1983	Svedman	5,149,331 A	9/1992	Ferdman et al.
4,392,853 A	7/1983	Muto	5,151,314 A	9/1992	Brown
4,392,858 A	7/1983	George et al.	5,152,757 A	10/1992	Eriksson
4,414,970 A	11/1983	Berry	5,167,613 A	12/1992	Karami et al.
4,419,097 A	12/1983	Rowland	5,176,663 A	1/1993	Svedman et al.
4,465,485 A	8/1984	Kashmer et al.	5,180,375 A	1/1993	Feibus
4,475,909 A	10/1984	Eisenberg	5,215,522 A	6/1993	Page et al.
4,480,638 A	11/1984	Schmid	5,232,453 A	8/1993	Plass et al.
4,525,166 A	6/1985	Leclerc	5,261,893 A	11/1993	Zamierowski
4,525,374 A	6/1985	Vaillancourt	5,266,372 A	11/1993	Arakawa et al.
4,529,402 A	7/1985	Weilbacher et al.	5,270,358 A	12/1993	Asmus
4,540,412 A	9/1985	Van Overloop	5,278,100 A	1/1994	Doan et al.
4,543,100 A	9/1985	Brodsky	5,279,550 A	1/1994	Habib et al.
4,548,202 A	10/1985	Duncan	5,298,015 A	3/1994	Komatsuzaki et al.
4,551,139 A	11/1985	Plaas et al.	5,342,329 A	8/1994	Croquevielle
4,569,348 A	2/1986	Hasslinger	5,342,376 A	8/1994	Ruff
4,600,001 A *	7/1986	Gilman <i>A61F 13/023</i> 602/52	5,344,415 A	9/1994	DeBusk et al.
4,605,399 A	8/1986	Weston et al.	5,356,386 A	10/1994	Goldberg et al.
4,608,041 A	8/1986	Nielsen	5,358,494 A	10/1994	Svedman
4,640,688 A	2/1987	Hauser	5,384,174 A	1/1995	Ward et al.
4,655,754 A	4/1987	Richmond et al.	5,387,207 A	2/1995	Dyer et al.
4,664,652 A	5/1987	Weilbacher	5,419,769 A	5/1995	Devlin et al.
4,664,662 A	5/1987	Webster	5,423,778 A	6/1995	Eriksson et al.
			5,429,590 A	7/1995	Saito et al.
			5,437,622 A	8/1995	Carion
			5,437,651 A	8/1995	Todd et al.
			5,445,604 A	8/1995	Lang
			5,447,492 A	9/1995	Cartmell et al.
			5,501,212 A	3/1996	Psaros
			5,512,041 A	4/1996	Bogart
			5,522,808 A	6/1996	Skalla
			5,527,293 A	6/1996	Zamierowski
			5,549,584 A	8/1996	Gross
			5,549,585 A	8/1996	Maher et al.
			5,556,375 A	9/1996	Ewall
			5,585,178 A	12/1996	Calhoun et al.
			5,599,292 A	2/1997	Yoon
			5,607,388 A	3/1997	Ewall
			5,634,893 A	6/1997	Rishton
			5,636,643 A	6/1997	Argenta et al.
			5,641,506 A	6/1997	Talke et al.

(56)

References Cited

U.S. PATENT DOCUMENTS

5,645,081	A	7/1997	Argenta et al.	2004/0030304	A1	2/2004	Hunt et al.
5,653,224	A	8/1997	Johnson	2004/0064132	A1	4/2004	Boehringer et al.
5,678,564	A	10/1997	Lawrence et al.	2004/0077984	A1	4/2004	Worthley
5,710,233	A	1/1998	Meckel et al.	2004/0099268	A1	5/2004	Smith et al.
5,714,225	A	2/1998	Hansen et al.	2004/0118401	A1	6/2004	Smith et al.
5,736,470	A	4/1998	Schneberger et al.	2004/0127836	A1	7/2004	Sigurjonsson et al.
5,776,119	A	7/1998	Bilbo et al.	2004/0127862	A1	7/2004	Bubb et al.
5,807,295	A	9/1998	Hutcheon et al.	2004/0133143	A1	7/2004	Burton et al.
5,919,476	A	7/1999	Fischer et al.	2004/0186239	A1	9/2004	Qin et al.
5,941,863	A	8/1999	Guidotti et al.	2004/0219337	A1	11/2004	Langley et al.
5,981,822	A	11/1999	Addison	2004/0230179	A1	11/2004	Shehada
6,071,267	A	6/2000	Zamierowski	2005/0034731	A1	2/2005	Rousseau et al.
6,086,995	A	7/2000	Smith	2005/0054998	A1	3/2005	Poccia et al.
6,135,116	A	10/2000	Vogel et al.	2005/0059918	A1	3/2005	Sigurjonsson et al.
6,174,306	B1	1/2001	Fleischmann	2005/0065484	A1	3/2005	Watson
6,191,335	B1	2/2001	Robinson	2005/0070858	A1	3/2005	Lockwood et al.
6,241,747	B1	6/2001	Ruff	2005/0101940	A1	5/2005	Radl et al.
6,262,329	B1	7/2001	Brunsveld et al.	2005/0113732	A1	5/2005	Lawry
6,287,316	B1	9/2001	Agarwal et al.	2005/0124925	A1	6/2005	Scherpenborg
6,345,623	B1	2/2002	Heaton et al.	2005/0131327	A1	6/2005	Lockwood et al.
6,458,109	B1	10/2002	Henley et al.	2005/0137539	A1	6/2005	Biggie et al.
6,488,643	B1	12/2002	Tumey et al.	2005/0143694	A1	6/2005	Schmidt et al.
6,493,568	B1	12/2002	Bell et al.	2005/0159695	A1	7/2005	Cullen et al.
6,495,229	B1	12/2002	Carte et al.	2005/0161042	A1	7/2005	Fudge et al.
6,548,727	B1	4/2003	Swenson	2005/0163978	A1	7/2005	Strobech et al.
6,553,998	B2	4/2003	Heaton et al.	2005/0214376	A1	9/2005	Faure et al.
6,566,575	B1	5/2003	Stickels et al.	2005/0233072	A1	10/2005	Stephan et al.
6,566,577	B1	5/2003	Addison et al.	2005/0256437	A1	11/2005	Silcock et al.
6,626,891	B2	9/2003	Ohmstede	2005/0261642	A1	11/2005	Weston
6,627,215	B1	9/2003	Dale et al.	2005/0261643	A1	11/2005	Bybordi et al.
6,648,862	B2	11/2003	Watson	2005/0277860	A1	12/2005	Jensen
6,680,113	B1	1/2004	Lucast et al.	2006/0079852	A1	4/2006	Bubb et al.
6,685,681	B2	2/2004	Lockwood et al.	2006/0083776	A1	4/2006	Bott et al.
6,693,180	B2	2/2004	Lee et al.	2006/0154546	A1	7/2006	Murphy et al.
6,695,823	B1	2/2004	Lina et al.	2006/0241542	A1	10/2006	Gudnason et al.
6,752,794	B2	6/2004	Lockwood et al.	2006/0271020	A1	11/2006	Huang et al.
6,787,682	B2	9/2004	Gilman	2007/0027414	A1	2/2007	Hoffman et al.
6,814,079	B2	11/2004	Heaton et al.	2007/0078366	A1	4/2007	Haggstrom et al.
6,855,135	B2	2/2005	Lockwood et al.	2007/0185426	A1	8/2007	Ambrosio et al.
6,856,821	B2	2/2005	Johnson	2007/0225663	A1	9/2007	Watt et al.
6,979,324	B2	12/2005	Bybordi et al.	2007/0265585	A1	11/2007	Joshi et al.
7,070,584	B2	7/2006	Johnson et al.	2007/0265586	A1	11/2007	Joshi et al.
7,154,017	B2	12/2006	Sigurjonsson et al.	2008/0090085	A1	4/2008	Kawate et al.
7,402,721	B2	7/2008	Sigurjonsson et al.	2008/0119802	A1	5/2008	Riesinger
7,569,742	B2	8/2009	Haggstrom et al.	2008/0149104	A1	6/2008	Eifler
7,645,269	B2	1/2010	Zamierowski	2008/0195017	A1	8/2008	Robinson et al.
8,298,197	B2	10/2012	Eriksson et al.	2008/0225663	A1	9/2008	Smith et al.
8,529,532	B2	9/2013	Pinto et al.	2008/0243044	A1	10/2008	Hunt et al.
8,632,523	B2	1/2014	Eriksson et al.	2008/0269657	A1	10/2008	Brenneman et al.
8,764,732	B2	7/2014	Hartwell	2008/0271804	A1	11/2008	Biggie et al.
9,192,444	B2	11/2015	Locke et al.	2009/0025724	A1	1/2009	Herron, Jr.
2001/0030304	A1	10/2001	Kohda et al.	2009/0088719	A1	4/2009	Driskell
2001/0051178	A1	12/2001	Blatchford et al.	2009/0093779	A1	4/2009	Riesinger
2002/0009568	A1	1/2002	Bries et al.	2009/0124988	A1	5/2009	Coulthard
2002/0016346	A1	2/2002	Brandt et al.	2009/0177172	A1	7/2009	Wilkes
2002/0065494	A1	5/2002	Lockwood et al.	2009/0216204	A1	8/2009	Bhavaraju et al.
2002/0077661	A1	6/2002	Saadat	2009/0227969	A1	9/2009	Jaeb et al.
2002/0115951	A1	8/2002	Norstrem et al.	2009/0264807	A1	10/2009	Haggstrom et al.
2002/0119292	A1	8/2002	Venkatasanthanam et al.	2009/0292264	A1	11/2009	Hudspeth et al.
2002/0120185	A1	8/2002	Johnson	2009/0312662	A1	12/2009	Colman et al.
2002/0130064	A1	9/2002	Adams et al.	2009/0326488	A1	12/2009	Budig et al.
2002/0143286	A1	10/2002	Tumey	2010/0063467	A1	3/2010	Addison et al.
2002/0150270	A1	10/2002	Werner	2010/0106106	A1	4/2010	Heaton et al.
2002/0150720	A1	10/2002	Howard et al.	2010/0106118	A1	4/2010	Heaton et al.
2002/0161346	A1	10/2002	Lockwood et al.	2010/0125259	A1	5/2010	Olson
2002/0164346	A1	11/2002	Nicolette	2010/0159192	A1	6/2010	Cotton
2002/0183702	A1	12/2002	Henley et al.	2010/0185163	A1	7/2010	Heagle
2002/0198504	A1	12/2002	Risk et al.	2010/0226824	A1	9/2010	Ophir et al.
2003/0014022	A1	1/2003	Lockwood et al.	2010/0262090	A1	10/2010	Riesinger
2003/0109855	A1	6/2003	Solem et al.	2010/0267302	A1	10/2010	Kantner et al.
2003/0158577	A1	8/2003	Ginn et al.	2010/0305490	A1	12/2010	Coulthard et al.
2003/0212357	A1	11/2003	Pace	2010/0305524	A1	12/2010	Vess et al.
2003/0225347	A1	12/2003	Argenta et al.	2010/0324516	A1	12/2010	Braga et al.
2003/0225355	A1	12/2003	Butler	2011/0046585	A1	2/2011	Weston
2004/0002676	A1	1/2004	Sieglwart et al.	2011/0112458	A1	5/2011	Holm et al.
				2011/0137271	A1	6/2011	Andresen et al.
				2011/0160686	A1*	6/2011	Ueda A61F 13/0203 604/365
				2011/0171480	A1	7/2011	Mori et al.

(56)

References Cited

U.S. PATENT DOCUMENTS

2011/0172617 A1 7/2011 Riesinger
 2011/0224631 A1 9/2011 Simmons et al.
 2011/0224634 A1* 9/2011 Locke A61F 13/00029
 604/319
 2011/0229688 A1 9/2011 Cotton
 2011/0244010 A1 10/2011 Doshi
 2011/0257617 A1 10/2011 Franklin
 2012/0016322 A1 1/2012 Coulthard et al.
 2012/0123359 A1 5/2012 Reed
 2012/0143157 A1 6/2012 Riesinger
 2012/0258271 A1 10/2012 Maughan
 2013/0030394 A1 1/2013 Locke et al.
 2013/0066285 A1 3/2013 Locke et al.
 2013/0096518 A1 4/2013 Hall et al.
 2013/0152945 A1 6/2013 Locke et al.
 2014/0012213 A1* 1/2014 Locke A61F 13/0216
 604/319
 2014/0039423 A1 2/2014 Riesinger
 2014/0039424 A1 2/2014 Locke
 2014/0058309 A1* 2/2014 Addison A61F 13/00029
 602/44
 2014/0155849 A1 6/2014 Heaton et al.
 2014/0171851 A1 6/2014 Addison
 2014/0309574 A1 10/2014 Cotton
 2014/0350494 A1 11/2014 Hartwell et al.
 2015/0030848 A1 1/2015 Goubard
 2015/0119830 A1 4/2015 Luckemeyer et al.
 2015/0190286 A1 7/2015 Allen et al.
 2016/0067107 A1 3/2016 Cotton

FOREIGN PATENT DOCUMENTS

AU 755496 B2 12/2002
 AU 2009200608 A1 10/2009
 CA 2005436 A1 6/1990
 CN 87101823 A 8/1988
 DE 26 40 413 A1 3/1978
 DE 43 06 478 A1 9/1994
 DE 29 504 378 U1 9/1995
 DE 202004018245 U1 7/2005
 EP 0097517 A1 1/1984
 EP 0100148 A1 2/1984
 EP 0117632 A2 9/1984
 EP 0161865 A2 11/1985
 EP 0251810 A2 1/1988
 EP 0275353 A2 7/1988
 EP 0358302 A2 3/1990
 EP 0538917 A1 4/1993
 EP 0630629 A1 12/1994
 EP 0659390 A2 6/1995
 EP 0633758 B1 10/1996
 EP 1002846 A1 5/2000
 EP 1018967 A1 7/2000
 EP 2578193 A1 4/2013
 GB 692578 A 6/1953
 GB 1386800 A 3/1975
 GB 2 195 255 A 4/1988
 GB 2 197 789 A 6/1988
 GB 2 220 357 A 1/1990
 GB 2 235 877 A 3/1991
 GB 2 329 127 A 3/1999
 GB 2 333 965 A 8/1999
 GB 2377939 A 1/2003
 GB 2392836 A 3/2004
 GB 2393655 A 4/2004
 GB 2425487 A 11/2006
 GB 2452720 A 3/2009
 GB 2496310 A 5/2013
 JP 1961003393 2/1961
 JP S62139523 U 9/1987
 JP S62-275456 A 11/1987
 JP 08-336555 A 12/1996
 JP 2007254515 A 10/2007
 JP 2008080137 A 4/2008

JP 4129536 B2 8/2008
 JP 2015501712 A 1/2015
 SG 71559 4/2002
 WO 80/02182 A1 10/1980
 WO 87/04626 A1 8/1987
 WO 8707164 A1 12/1987
 WO 90/010424 A1 9/1990
 WO 93/009727 A1 5/1993
 WO WO-93/13813 A1 7/1993
 WO WO-93/19709 A1 10/1993
 WO 94/020041 A1 9/1994
 WO WO-95/15135 A1 6/1995
 WO 96/05873 A1 2/1996
 WO 9622753 A1 8/1996
 WO 97/18007 A1 5/1997
 WO 99/13793 A1 3/1999
 WO 99/65542 A1 12/1999
 WO 01/36188 A1 5/2001
 WO 01/60296 A1 8/2001
 WO 0168021 A1 9/2001
 WO 0185248 A1 11/2001
 WO WO-02/20067 A2 3/2002
 WO 0243743 A1 6/2002
 WO 02062403 A1 8/2002
 WO 03-018098 A2 3/2003
 WO WO-03/043553 A1 5/2003
 WO 03045294 A1 6/2003
 WO 03045492 A1 6/2003
 WO 03053484 A1 7/2003
 WO 2004024197 A1 3/2004
 WO 2004037334 A1 5/2004
 WO WO-2004/060359 A1 7/2004
 WO WO-2004/060413 A1 7/2004
 WO 2004112852 A1 12/2004
 WO 2005002483 A2 1/2005
 WO 2005062896 A2 7/2005
 WO 2005105176 A1 11/2005
 WO 2005123170 A1 12/2005
 WO 2007022097 A2 2/2007
 WO 2007030601 A2 3/2007
 WO 2007070269 A1 6/2007
 WO 2007085396 A1 8/2007
 WO 2007087811 A1 8/2007
 WO 2007113597 A2 10/2007
 WO WO-2007/113597 A2 * 10/2007 A61F 13/0226
 WO 2007133618 A2 11/2007
 WO 2008041926 A1 4/2008
 WO 2008054312 A1 5/2008
 WO WO-2008/062176 A1 5/2008
 WO 2008/082444 A2 7/2008
 WO 2008/100440 A1 8/2008
 WO 2008104609 A1 9/2008
 WO 2008/131895 A1 11/2008
 WO 2009/002260 A1 12/2008
 WO 2008149107 A1 12/2008
 WO 2009066105 A1 5/2009
 WO 2009066106 A1 5/2009
 WO WO-2009/067062 A1 5/2009
 WO 2009081134 A1 7/2009
 WO 2009089016 A1 7/2009
 WO 2009/124100 A1 10/2009
 WO 2009126103 A1 10/2009
 WO 2010032728 A1 3/2010
 WO 2010/056977 A2 5/2010
 WO WO-2010/061228 A1 6/2010
 WO WO-2010/122665 A1 10/2010
 WO 2010129299 A2 11/2010
 WO 2011008497 A2 1/2011
 WO 2011/049562 A1 4/2011
 WO 2011043786 A1 4/2011
 WO 2011115908 A1 9/2011
 WO 2011121127 A1 10/2011
 WO 2011162862 A1 12/2011
 WO 2012/112204 A1 8/2012
 WO 2012104584 A1 8/2012
 WO 2012140378 A1 10/2012
 WO 2012143665 A1 10/2012
 WO WO-2012/140378 A1 10/2012
 WO 2013009239 A1 1/2013

(56) **References Cited**

FOREIGN PATENT DOCUMENTS

WO	2013090810 A1	6/2013
WO	2014039557 A1	3/2014
WO	2014/113253 A1	7/2014
WO	2014140608 A1	9/2014
WO	2014143488 A1	9/2014
WO	2015/065615 A1	5/2015
WO	2015130471 A1	9/2015

OTHER PUBLICATIONS

Susan Mendez-Eatmen, RN; "When wounds Won't Heal" RN Jan. 1998, vol. 61 (1); Medical Economics Company, Inc., Montvale, NJ, USA; pp. 20-24.

James H. Blackburn II, MD et al.: Negative-Pressure Dressings as a Bolster for Skin Grafts; *Annals of Plastic Surgery*, vol. 40, No. 5, May 1998, pp. 453-457; Lippincott Williams & Wilkins, Inc., Philadelphia, PA, USA.

John Masters; "Reliable, Inexpensive and Simple Suction Dressings"; Letter to the Editor, *British Journal of Plastic Surgery*, 198, vol. 51 (3), p. 267; Elsevier Science/The British Association of Plastic Surgeons, UK.

S.E. Greer, et al. "The Use of Subatmospheric Pressure Dressing Therapy to Close Lymphocutaneous Fistulas of the Groin" *British Journal of Plastic Surgery* (2000), 53, pp. 484-487.

George V. Letsou, MD., et al; "Stimulation of Adenylate Cyclase Activity in Cultured Endothelial Cells Subjected to Cyclic Stretch"; *Journal of Cardiovascular Surgery*, 31, 1990, pp. 634-639.

Orringer, Jay, et al; "Management of Wounds in Patients with Complex Enterocutaneous Fistulas"; *Surgery, Gynecology & Obstetrics*, Jul. 1987, vol. 165, pp. 79-80.

International Search Report for PCT International Application PCT/GB95/01983; dated Nov. 23, 1995.

PCT International Search Report for PCT International Application PCT/GB98/02713; dated Jan. 8, 1999.

PCT Written Opinion; PCT International Application PCT/GB98/02713; dated Jun. 8, 1999.

PCT International Examination and Search Report, PCT International Application PCT/GB96/02802; dated Jan. 15, 1998 & Apr. 29, 1997.

PCT Written Opinion, PCT International Application PCT/GB96/02802; dated Sep. 3, 1997.

Dattilo, Philip P., Jr., et al; "Medical Textiles: Application of an Absorbable Barbed Bi-directional Surgical Suture"; *Journal of Textile and Apparel, Technology and Management*, vol. 2, Issue 2, Spring 2002, pp. 1-5.

Kostyuchenok, B.M., et al; "Vacuum Treatment in the Surgical Management of Purulent Wounds"; *Vestnik Khirurgi*, Sep. 1986, pp. 18-21 and 6 page English translation thereof.

Davydov, Yu. A., et al; "Vacuum Therapy in the Treatment of Purulent Lactation Mastitis"; *Vestnik Khirurgi*, May 14, 1986, pp. 66-70, and 9 page English translation thereof.

Yusupov, Yu.N., et al; "Active Wound Drainage", *Vestniki Khirurgi*, vol. 138, Issue 4, 1987, and 7 page English translation thereof.

Davydov, Yu.A., et al; "Bacteriological and Cytological Assessment of Vacuum Therapy for Purulent Wounds"; *Vestnik Khirurgi*, Oct. 1988, pp. 48-52, and 8 page English translation thereof.

Davydov, Yu.A., et al; "Concepts for the Clinical-Biological Management of the Wound Process in the Treatment of Purulent Wounds by Means of Vacuum Therapy"; *Vestnik Khirurgi*, Jul. 7, 1980, pp. 132-136, and 8 page English translation thereof.

Chariker, Mark E., M.D., et al; "Effective Management of incisional and cutaneous fistulae with closed suction wound drainage"; *Contemporary Surgery*, vol. 34, Jun. 1989, pp. 59-63.

Egnell Minor, Instruction Book, First Edition, 300 7502, Feb. 1975, pp. 24.

Egnell Minor: Addition to the Users Manual Concerning Overflow Protection—Concerns all Egnell Pumps, Feb. 3, 1983, pp. 2.

Svedman, P.: "Irrigation Treatment of Leg Ulcers", *The Lancet*, Sep. 3, 1983, pp. 532-534.

Chinn, Steven D. et al.: "Closed Wound Suction Drainage", *The Journal of Foot Surgery*, vol. 24, No. 1, 1985, pp. 76-81.

Arnljots, Bjöm et al.: "Irrigation Treatment in Split-Thickness Skin Grafting of Intractable Leg Ulcers", *Scand J. Plast Reconstr. Surg.*, No. 19, 1985, pp. 211-213.

Svedman, P.: "A Dressing Allowing Continuous Treatment of a Biosurface", *IRCS Medical Science: Biomedical Technology, Clinical Medicine, Surgery and Transplantation*, vol. 7, 1979, p. 221.

Svedman, P. et al: "A Dressing System Providing Fluid Supply and Suction Drainage Used for Continuous of Intermittent Irrigation", *Annals of Plastic Surgery*, vol. 17, No. 2, Aug. 1986, pp. 125-133.

N.A. Bagautdinov, "Variant of External Vacuum Aspiration in the Treatment of Purulent Diseases of Soft Tissues," *Current Problems in Modern Clinical Surgery: Interdepartmental Collection*, edited by V. Ye Volkov et al. (Chuvashia State University, Cheboksary, U.S.S.R. 1986); pp. 94-96 (copy and certified translation).

K.F. Jeter, T.E. Tittle, and M. Chariker, "Managing Draining Wounds and Fistulae: New and Established Methods," *Chronic Wound Care*, edited by D. Krasner (Health Management Publications, Inc., King of Prussia, PA 1990), pp. 240-246.

G. Živadinovi?, V. ?uki?, Ž. Maksimovi?, ?. Radak, and P. Peška, "Vacuum Therapy in the Treatment of Peripheral Blood Vessels," *Timok Medical Journal* 11 (1986), pp. 161-164 (copy and certified translation).

F.E. Johnson, "An Improved Technique for Skin Graft Placement Using a Suction Drain," *Surgery, Gynecology, and Obstetrics* 159 (1984), pp. 584-585.

A.A. Safronov, Dissertation Abstract, Vacuum Therapy of Trophic Ulcers of the Lower Leg with Simultaneous Autoplasty of the Skin (Central Scientific Research Institute of Traumatology and Orthopedics, Moscow, U.S.S.R. 1967) (copy and certified translation).

M. Schein, R. Saadia, J.R. Jamieson, and G.A.G. Decker, "The 'Sandwich Technique' in the Management of the Open Abdomen," *British Journal of Surgery* 73 (1986), pp. 369-370.

D.E. Tribble, An Improved Sump Drain-Irrigation Device of Simple Construction, *Archives of Surgery* 105 (1972) pp. 511-513.

M.J. Morykwas, L.C. Argenta, E.I. Shelton-Brown, and W. McGuirt, "Vacuum-Assisted Closure: A New Method for Wound Control and Treatment: Animal Studies and Basic Foundation," *Annals of Plastic Surgery* 38 (1997), pp. 553-562 (Morykwas I).

C.E. Tennants, "The Use of Hypermia in the Postoperative Treatment of Lesions of the Extremities and Thorax," *Journal of the American Medical Association* 64 (1915), pp. 1548-1549.

Selections from W. Meyer and V. Schmieden, Bier's Hyperemic Treatment in Surgery, Medicine, and the Specialties: A Manual of Its Practical Application, (W.B. Saunders Co., Philadelphia, PA 1909), pp. 17-25, 44-64, 90-96, 167-170, and 210-211.

V.A. Solovev et al., Guidelines, The Method of Treatment of Immature External Fistulas in the Upper Gastrointestinal Tract, editor-in-chief Prov. V.I. Parahonyak (S.M. Kirov Gorky State Medical Institute, Gorky, U.S.S.R. 1987) ("Solovev Guidelines").

V.A. Kuznetsov & N.A. Bagautdinov, "Vacuum and Vacuum-Sorption Treatment of Open Septic Wounds," in II All-Union Conference on Wounds and Wound Infections: Presentation Abstracts, edited by B.M. Kostyuchenok et al. (Moscow, U.S.S.R. Oct. 28-29, 1986) pp. 91-92 ("Bagautdinov II").

V.A. Solovev, Dissertation Abstract, Treatment and Prevention of Suture Failures after Gastric Resection (S.M. Kirov Gorky State Medical Institute, Gorky, U.S.S.R. 1988) ("Solovev Abstract").

V.A.C.® Therapy Clinical Guidelines: A Reference Source for Clinicians; Jul. 2007.

M. Waring et al., "Cell attachment to adhesive dressing: qualitative and quantitative analysis", *Wounds, UK*, (2008), vol. 4, No. 3, pp. 35-47.

R. White, "Evidence for atraumatic soft silicone wound dressing use". *Wound, UK* (2005), vol. 3, pp. 104-108, Mepilex Border docs, (2001).

European Search Report for corresponding application 17183683.6, dated Sep. 18, 2017.

European Search Report for corresponding application 17164033.7, dated Oct. 13, 2017.

Extended European Search Report for corresponding application 17191970.7, dated Oct. 26, 2017.

(56)

References Cited

OTHER PUBLICATIONS

International Search Report and Written Opinion for PCT/GB2008/003075 dated Mar. 11, 2010.

International Search Report and Written Opinion for PCT/GB2008/004216 dated Jul. 2, 2009.

International Search Report and Written Opinion for PCT/GB2012/000099 dated May 2, 2012.

EP Examination Report for corresponding application 12705381.7, dated May 22, 2014.

International Search Report and Written Opinion for PCT/US2012/069893 dated Apr. 8, 2013.

International Search Report and Written Opinion for PCT/US2013/070070 dated Jan. 29, 2014.

International Search Report and Written Opinion for PCT/US2014/016320 dated Apr. 15, 2014.

International Search Report and Written Opinion for PCT/US2014/056566 dated Dec. 5, 2014.

International Search Report and Written Opinion for PCT/US2014/056508 dated Dec. 9, 2014.

International Search Report and Written Opinion for PCT/US2014/056524 dated Dec. 11, 2014.

International Search Report and Written Opinion for PCT/US2014/056594 dated Dec. 2, 2014.

International Search Report and Written opinion dated Dec. 15, 2009; PCT International Application No. PCT/US2009/036222.

Response filed Oct. 20, 2011 for U.S. Appl. No. 12/398,904.

Interview Summary dated Oct. 27, 2011 for U.S. Appl. No. 12/398,904.

Non-Final Office Action dated Jul. 20, 2011 for U.S. Appl. No. 12/398,904.

V.A. Solovev et al., Guidelines, The Method of Treatment of Immature External Fistulas in the Upper Gastrointestinal Tract, editor-in-chief Prov. V.I. Parahonyak (S.M. Kirov Gorky State Medical Institute, Gorky, U.S.S.R. 1987) ("Solovev Guidelines").

V.A. Kuznetsov & N.a. Bagautdinov, "Vacuum and Vacuum-Sorption Treatment of Open Septic Wounds," in All-Union Conference on Wounds and Wound Infections: Presentation Abstracts, edited by B.M. Kostyuchenok et al. (Moscow, U.S.S.R. Oct. 28-29, 1986) pp. 91-92 ("Bagautdinov II").

NDP 1000 Negative Pressure Wound Therapy System, Kalypto Medical, pp. 1-4.

Examination report for AU2009221772 dated Apr. 4, 2013.

Response filed Oct. 21, 2011 for U.S. Appl. No. 12/398,891.

Interview Summary dated Oct. 27, 2011 for U.S. Appl. No. 12/398,891.

Restriction Requirement dated Jun. 13, 2011 for U.S. Appl. No. 12/398,891.

Response filed Jun. 24, 2011 for U.S. Appl. No. 12/398,891.

Non-Final Office Action dated Jul. 21, 2011 for U.S. Appl. No. 12/398,891.

International Search Report and Written Opinion dated Oct. 19, 2010; PCT International Application No. PCT/US2009/036217.

NPD 1000 Negative Pressure Wound Therapy System, Kalypto Medical, pp. 1-4.

Non-Final Rejection for U.S. Appl. No. 12/398,904 dated Mar. 14, 2012.

Response to Non-Final Rejection for U.S. Appl. No. 12/398,904, filed Jun. 4, 2012.

International Search Report and Written Opinion for PCT/US2014/061251 dated May 8, 2015.

International Search Report and Written Opinion for PCT/IB2013/060862 dated Jun. 26, 2014.

International Search Report and Written Opinion for PCT/US2015/015493 dated May 4, 2015.

European Search Report for corresponding Application No. 15194949.2.

European Examination Report dated Jun. 29, 2016, corresponding to EP Application No. 16173614.5.

European Search Report for corresponding EPSN 15157408.4 published on Sep. 30, 2015.

International Search Report and Written Opinion for PCT/US2015/034289 dated Aug. 21, 2015.

International Search Report and Written Opinion for PCT/US2015/065135 dated Apr. 4, 2016.

International Search Report and Written Opinion for PCT/GB2012/050822 dated Aug. 8, 2012.

International Search Report and Written Opinion for PCT/US2015/029037 dated Sep. 4, 2015.

International Search Report and Written Opinion dated Jun. 1, 2011 for PCT International Application No. PCT/US2011/028344.

European Search Report for EP 11714148.1, dated May 2, 2014.

European Search Report for corresponding Application No. 15192606.0 dated Feb. 24, 2016.

International Search Report and Written Opinion for corresponding PCT/US2014/048081 dated Nov. 14, 2014.

International Search Report and Written Opinion for corresponding PCT/US2014/010704 dated Mar. 25, 2014.

International Search Report and Written Opinion for corresponding PCT application PCT/US2016/051768 dated Dec. 15, 2016.

European Search Report for corresponding EP Application 171572787 dated Jun. 6, 2017.

International Search Report and Written Opinion for corresponding application PCT/US2016/031397, dated Aug. 8, 2016.

European Search Report for corresponding application 17167872.5, dated Aug. 14, 2017.

* cited by examiner

FIG. 1

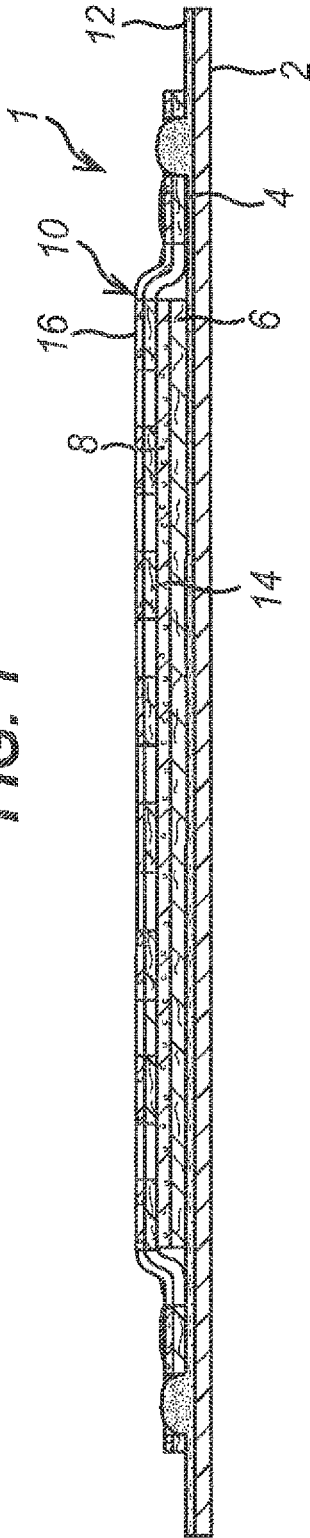
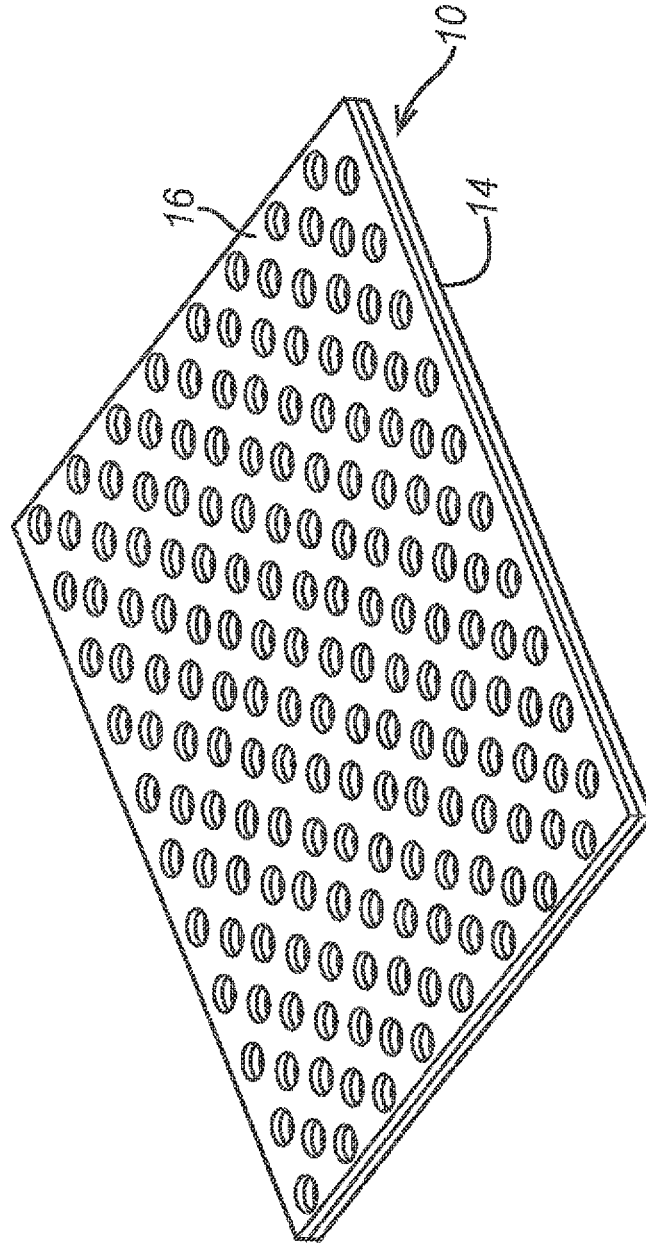

FIG. 2



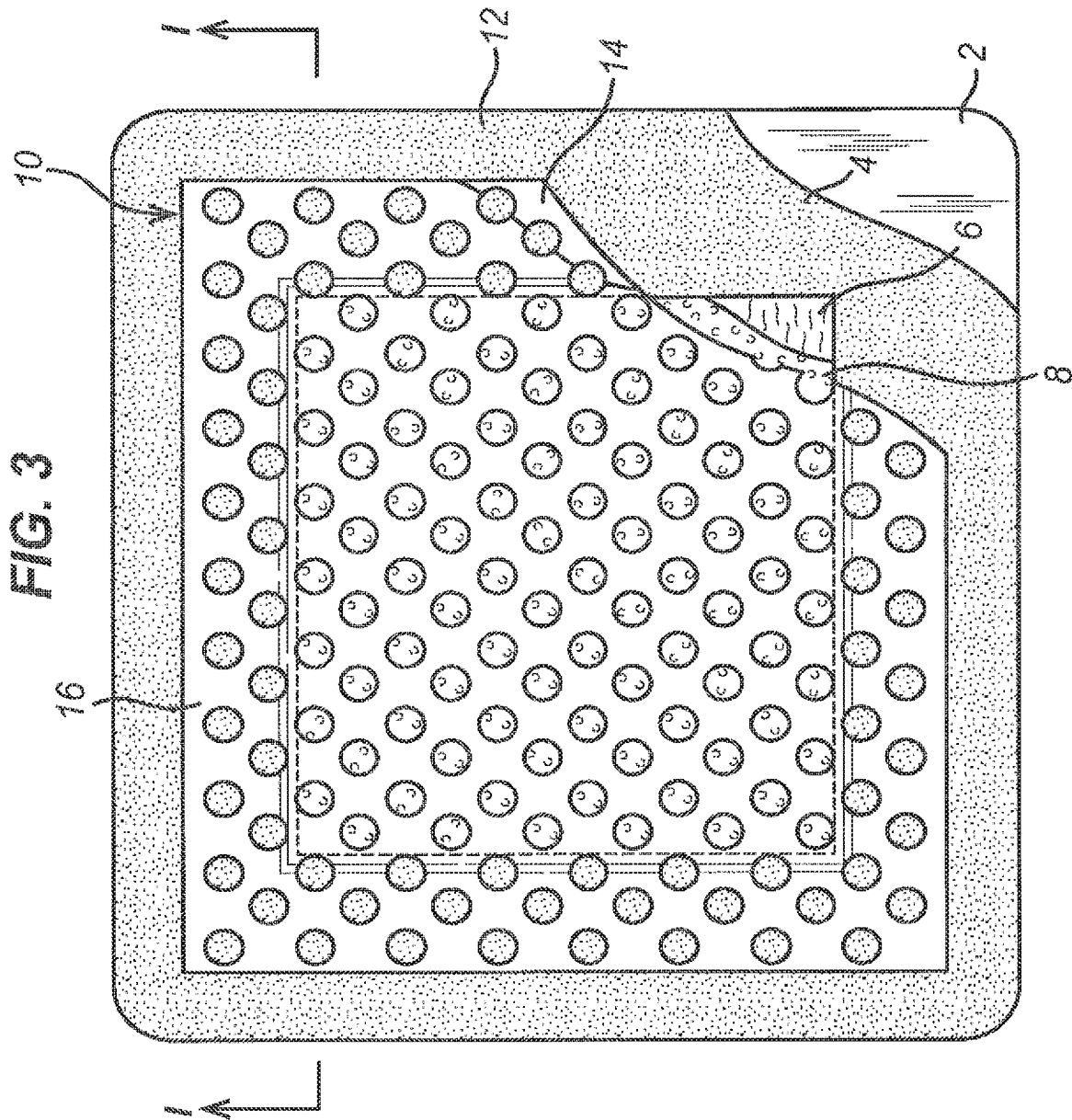

FIG. 4

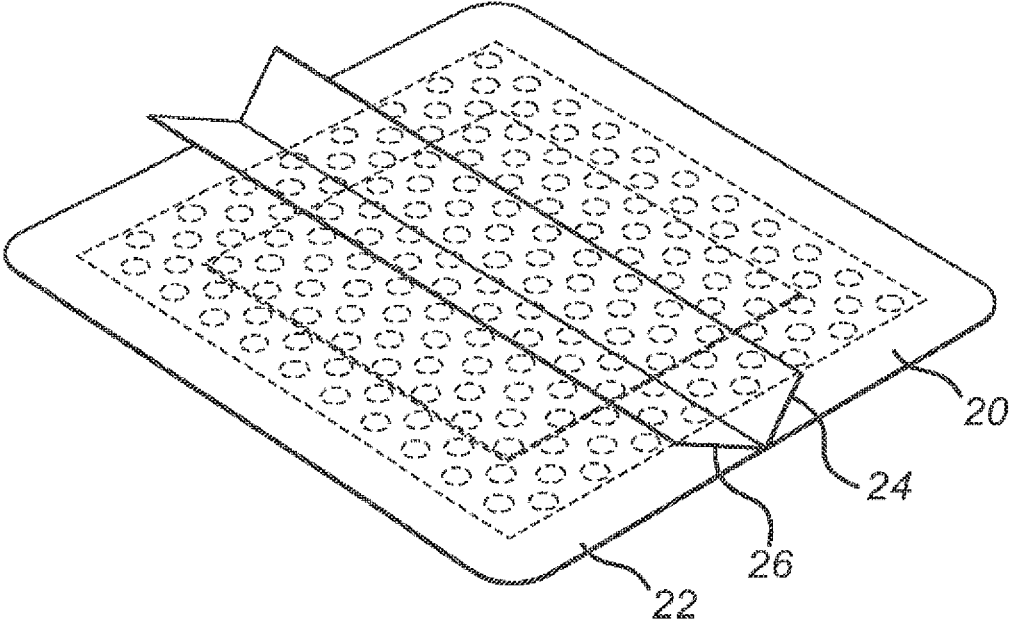

FIG. 5

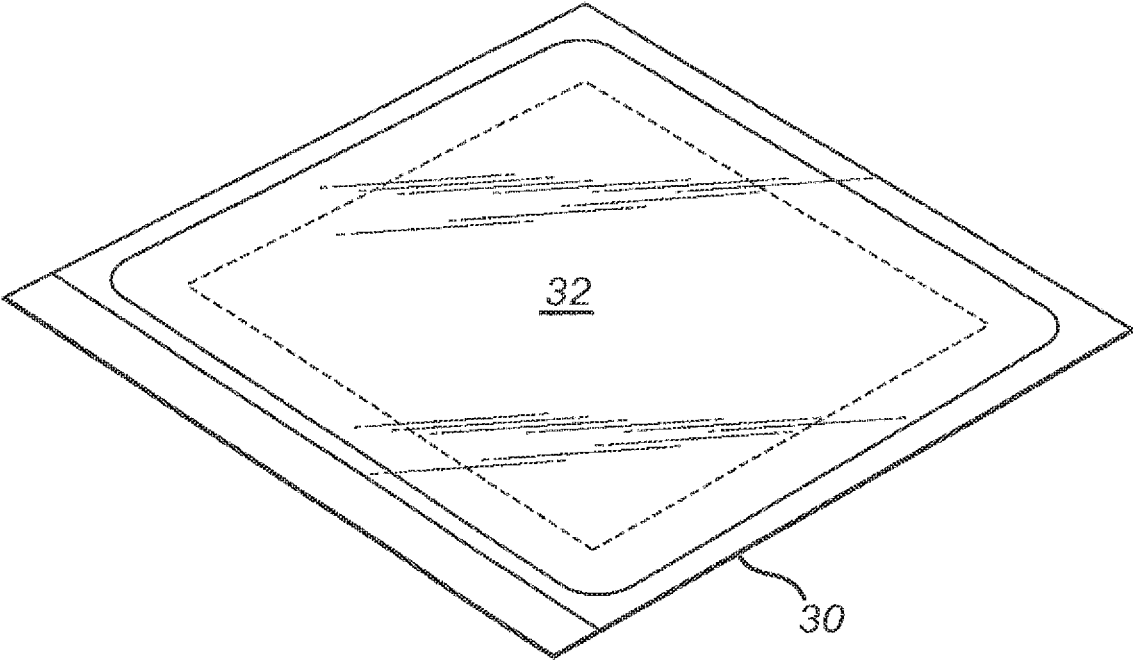

FIG. 6

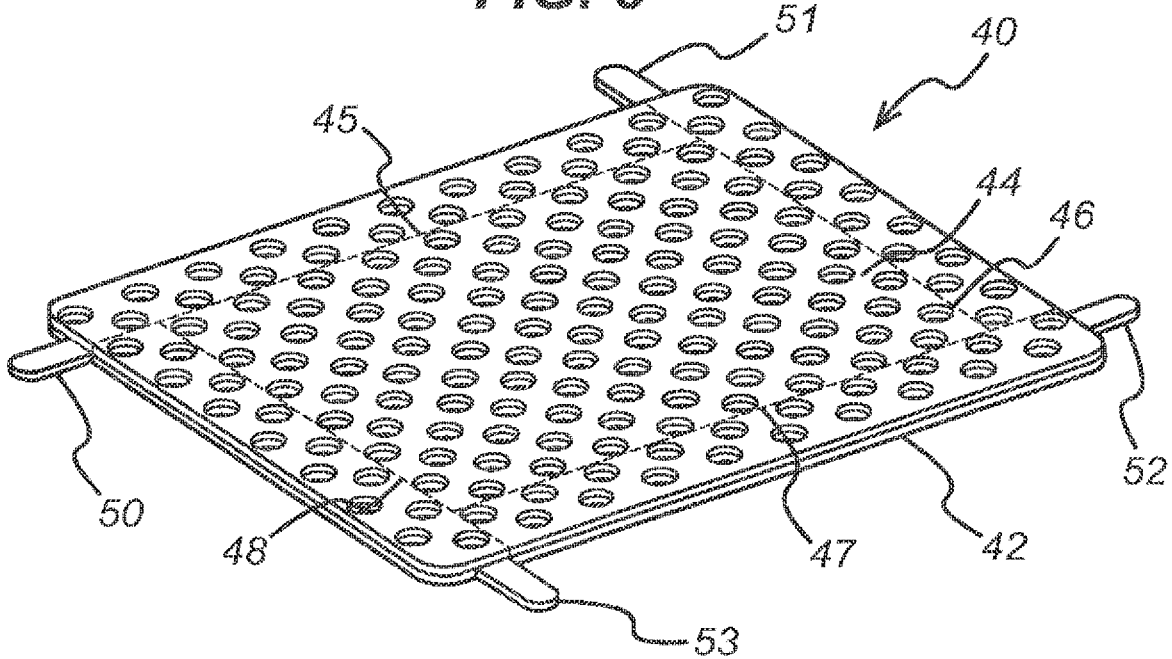

FIG. 7

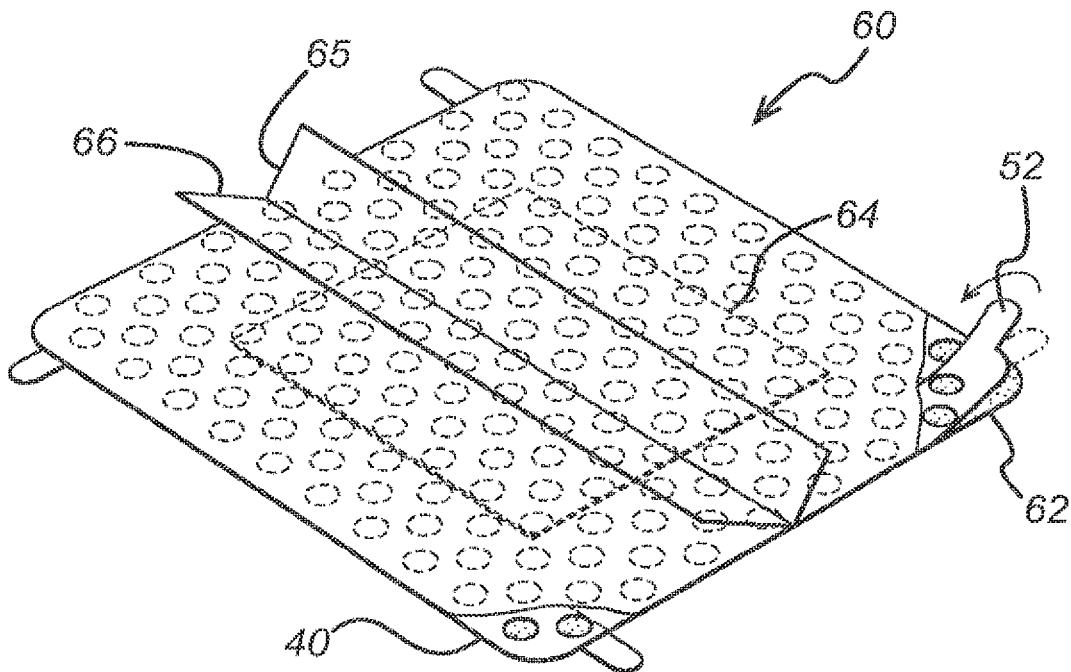
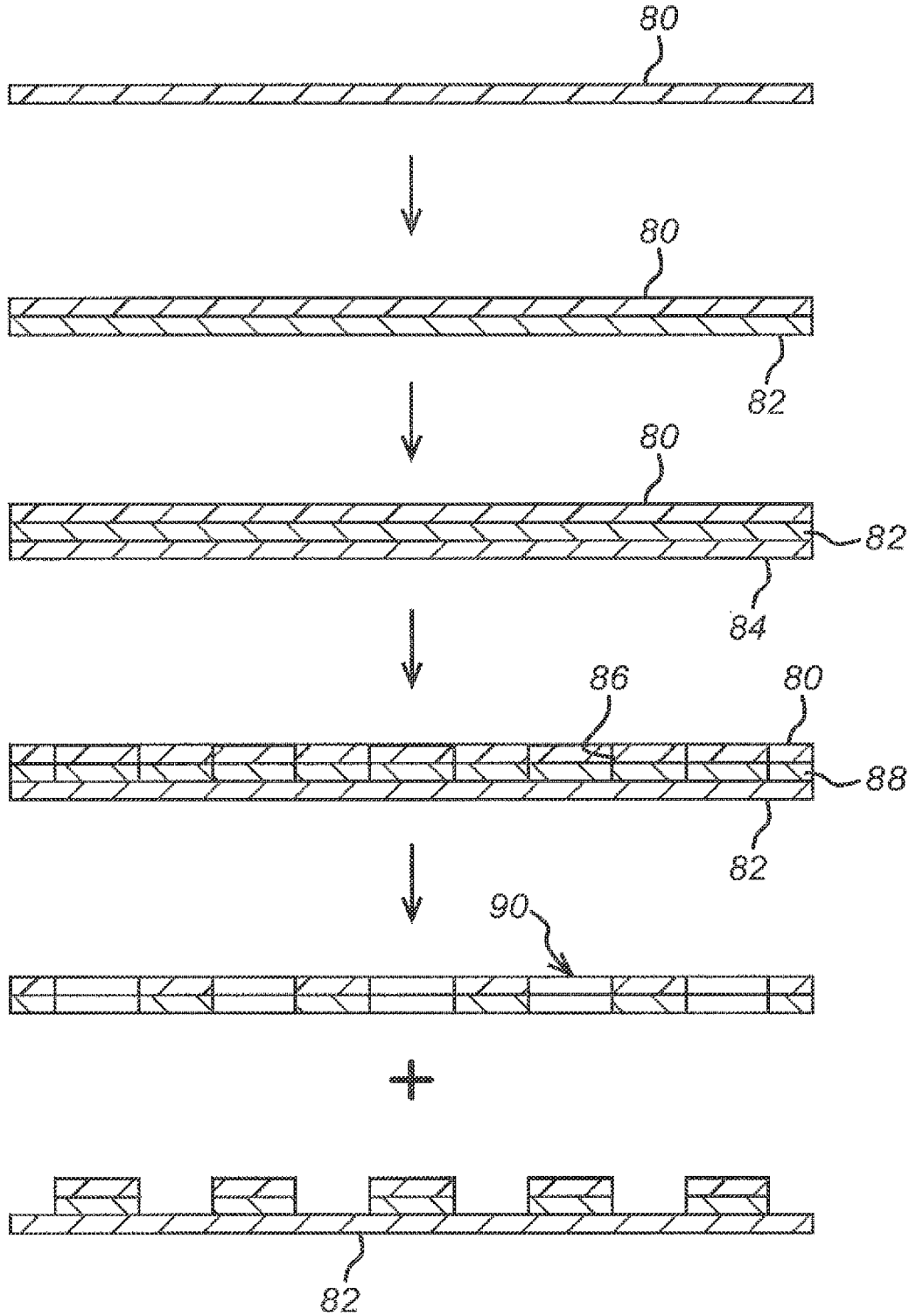

FIG. 8



WOUND DRESSING WITH ADHESIVE MARGIN

This application is a continuation of U.S. Non-Provisional patent application Ser. No. 14/653,760 filed on Jun. 18, 2015, entitled "Wound Dressing with Adhesive Margin," which claims the priority benefit of PCT Application No. PCT/1132013/060862, filed on Dec. 12, 2013, which claims the priority benefit of GB 1222770.8, filed on Dec. 18, 2012, all of which are incorporated herein by reference for all purposes.

The present invention relates to island-type wound dressings.

Island-type wound dressings comprise an absorbent region and an adhesive backing sheet covering the absorbent region and extending beyond the edges of the absorbent region to provide an adhesive margin around the absorbent region for attachment of the dressing to intact skin around the wound to be treated. The adhesive margin provides secure attachment of the dressing without the need for secondary dressings such as a bandage. The adhesive margin also reduces or prevents leakage of wound exudate from the edges of the dressing.

The adhesive used in such dressings is typically a medically acceptable pressure-sensitive adhesive (PSA) such as an acrylic-based PSA. Such adhesives provide a strong bond to skin, but as a result they are not readily repositionable, and they may cause skin irritation and/or discomfort when the dressing is removed. Moreover, the PSA is not normally permeable to oxygen or water vapour and therefore interferes with normal skin transpiration.

It is known to provide a discontinuous, e.g. patterned, layer of the PSA in order to address the above problems. However, application of a patterned layer of PSA increases the complexity of the manufacturing process and increases the risk of liquid leakage through the PSA to the edges of the dressing.

In a first aspect, the present invention provides a wound dressing comprising: a backing sheet, a layer of pressure-sensitive adhesive on the backing sheet; an island of absorbent material having smaller area than the backing sheet and applied onto a central region of the backing sheet so as to leave a margin of adhesive-coated backing sheet around the absorbent material, and an apertured wound facing layer applied over the absorbent material and adhered to the backing sheet around said island by said pressure-sensitive adhesive, wherein the apertured wound facing layer comprises an apertured substrate having a coating of a silicone elastomer on the wound facing surface thereof, the open area of the apertured wound facing layer is from about 5% to about 75%, and the aperture wound facing layer-comprises apertures having an open area of from about 2 mm² to about 100 mm².

The adhesive-coated backing sheet may have any shape, such as square, rectangular, circular, oval, trapezium-shaped, suitably with rounded corners.

The adhesive-trolled backing sheet supports the absorbent island and suitably provides a barrier to passage of microorganisms through the dressing. Suitably, the adhesive-coated backing sheet is substantially liquid-impermeable. The adhesive-coated backing sheet is suitably semipermeable. That is to say, the adhesive-coated backing sheet is suitably permeable to water vapour, but not permeable to liquid water or wound exudate. Suitably, the adhesive-coated backing sheet is also microorganism-impermeable. Suitably continuous conformable adhesive-coated backing sheets will suitably have a moisture vapor transmission rate

(MVTR) of the backing sheet alone of 300 to 30000 g/m²/24 hrs, suitably 1000 to 1500 g/m²/24 hrs, and in one embodiment 1000 to 5000 g/m²/24 hrs, at 37.5° C. at 100% to 10% relative humidity difference. The adhesive-coated backing sheet thickness is suitably in the range of 10 to 1000 micrometers, more suitably 100 to 500 micrometers.

Suitable polymers for forming the adhesive-coated backing sheet include polyurethanes and poly alkoxyalkyl acrylates and methacrylates such as those disclosed in GB-A-1280631. Suitably, the adhesive-coated backing sheet comprises a continuous layer of a high density blocked polyurethane foam that is predominantly closed-cell. A suitable adhesive-coated backing sheet material is the polyurethane film available under the Registered Trade Mark ESTANE 5714F. Also suitable are elastomeric polymeric esters such as Du Pont HYTREL (Registered Trade Mark).

The absorbent island may comprise any of the layers conventionally used for absorbing wound fluids, serum or blood in the wound healing art, including gauzes, nonwoven fabrics, superabsorbents, hydrogels and mixtures thereof. Suitably, the absorbent island comprises a layer of hydrophilic polyurethane foam on a wound facing side thereof, such as an open celled hydrophilic polyurethane foam prepared in accordance with EP-A-0541391. The absorbent island may further comprise a wicking layer. This may be a layer of a nonwoven fibrous web, for example a carded web of viscose staple fibers. The basis weight of the absorbent layer may suitably be in the range of 50-500 g/m², such as 100-400 g/m². The uncompressed thickness of the absorbent layer may be in the range of from 0.5 mm to 10 mm, such as 1 mm to 4 mm. The free (uncompressed) liquid absorbency measured for physiological saline may suitably be in the range of 5 to 30 g/g at 25° C.

The area of the absorbent island is suitably in the range of from 1 cm² to 400 cm², more suitably from 4 cm² to 200 cm², still more suitably from about 10 cm² to about 150 cm², for example from about 16 cm² to about 100 cm². Dressings of the latter size are especially suitable for the treatment of leg ulcers.

The island has a smaller area than the adhesive-coated backing sheet such that an adhesive-coated margin of the backing sheet extends around the island. Normally, the adhesive-coated margin extends around every edge of the absorbent island. Suitably, the adhesive-coated margin has a mean width of from 0.5 to 5 cm, suitably from 1 to 3 cm. The adhesive-coated margin may be made up of an inner margin covered by the apertured coated layer, and an outer margin extending outside the apertured coated layer, as explained further below.

The pressure-sensitive adhesive layer is suitably pressure-sensitive adhesive layer of the type conventionally used for island-type wound dressings. The PSA layer is suitably a continuous layer, but it may be apertured or interrupted in some embodiments. Acrylic-based pressure sensitive adhesive are suitable. In embodiments, a pressure sensitive adhesive based on acrylate ester copolymers, polyvinyl ethyl ether and polyurethane as described for example in GB-A-1280631. The basis weight of the PSA layer is suitably 20 to 250 g/m², and more suitably 50 to 150 g/m².

The apertured layer having a coating of silicone elastomer provides a weakly adherent (tacky) or non-adherent wound facing layer over the absorbent layer. In addition, the apertured layer having a coating of silicone elastomer extends over at least part of the adhesive-coated margin. In this part of the margin, the apertured layer covers a portion of the PSA-coated surface of the backing sheet but allows adhesion of the pressure-sensitive adhesive through the apertures of

the layer resulting in reduced overall adherency of the backlog sheet in this part of the margin. The overlap of the apertured coated layer and the adhesive-coated backing sheet around the absorbent layer also serves to attach the apertured coated layer to the backing sheet thereby securing the laminate. The silicone elastomer coating is suitably hydrophobic, whereby leakage of wound fluid through the edges of the dressing is inhibited. The silicone elastomer coating may be tacky or non-tacky.

The apertures in the apertured layer are suitably large enough to allow skin contact of the backing layer PSA through the apertures when the dressing is applied to skin around a wound. Suitably, the said apertures have an open area of from about 4 mm² to about 50 mm², for example from about 5 mm² to about 30 mm². This refers to the average (mean) area of the apertures. Suitably, at least about 90% of the apertures in the apertured layer have open area in the specified ranges. Suitably, at least about 90%, for example substantially all, of the apertures have substantially the same size and shape. Suitably, said apertures consist essentially of a regular array of apertures. The apertures may be of any shape, but suitably they are circular, oval or polygonal. Suitably, the open area of the apertured layer is from about 10% to about 70% of the total area, for example from about 20% to about 50% of the total area, for example about 25% to about 40% of the total area. Suitably, the density of the apertures is from about 1000 to about 100,000 apertures per m², for example about 5000 to about 50,000 apertures per m².

Likewise, in order to ensure sufficient adherency of the PSA through the apertures of the apertured layer, the apertured layer is suitably thin. In embodiments, the thickness of the apertured wound facing layer is less than about 1 mm, for example from about 0.02 mm to about 0.5 mm, in embodiments from about 0.05 mm to about 0.2 mm. The term "thickness" in this context refers to the combined thickness of the silicone coating and substrate.

The apertured substrate may be any medically acceptable apertured sheet material, including textile materials such as gauzes. Suitably, the apertured substrate is a unitary substrate such as a unitary polymer mesh or an apertured polymer film. Suitable polymer materials include polyethylene, polypropylene, polyester, polyvinyl acetate, and ethylene vinyl acetate. Suitably, the film substrate has a thickness of from about 1 μm to about 100 μm, for example from about 5 μm to about 25 μm. In other embodiment the substrate is a woven or nonwoven textile material, typically having an uncompressed thickness of from about 0.1 mm to about 1 mm.

In embodiments, the apertured wound facing layer is smaller than the adhesive-coated backing sheet, whereby an adhesive-coated margin of the backing sheet extends around the apertured wound facing layer. This continuous PSA margin provides additional security of attachment and leak resistance around the edges of the dressing. However, it can be made narrower than the PSA-coated margin of conventional island dressings because of the adherency of the inner margin covered by the apertured layer. Thus, in embodiments, the margin of PSA-coated backing sheet around the absorbent island that is covered by the apertured layer has a mean width of from about 5 mm to about 30 mm, for example from about 10 mm to about 20 mm. The outer margin of PSA-coated backing sheet only (where present) has a mean width of from about 2 mm to about 20 mm, for example from about 5 mm to about 15 mm, typically about 10 mm.

In embodiments, the apertured wound facing material comprises lines or weakness substantially parallel to, and spaced from, one or more edges of the apertured wound facing material. These lines of weakness define tear-off strips along one or more edges of the apertured wound facing material that allow the size of the apertured wound facing material (and hence the width of the PSA-coated margin around the outside of the apertured wound facing material) to be varied according to the clinical requirements. Thus, for a heavily-exuding wound, a wider PSA-coated margin around the edges of the dressing may be desirable. On the other hand, for lightly exuding wounds, or where easy repositioning of the dressing is desirable, little or no PSA-coated margin around the outside of the apertured wound facing material may be preferable. Thus, in some embodiments the apertured wound facing sheet may be coterminous with the PSA-coated backing sheet prior to removal of any of the tear strips so that there is no continuously PSA-coated margin around the apertured wound facing sheet until removal of the tear strips.

The lines of weakness may, for example comprise lines of perforations or score lines. Suitably, one or more lines of weakness defining tear-off strips are defined in all edges of the apertured wound facing material so as to allow uniform increasing of the PSA-coated margin. Suitably, the width of the tear-off strips (i.e. the average spacing of the lines of weakness from the edges of the apertured sheet is from about 5 mm to about 20 mm, for example about 8 mm to about 15 mm. Suitably, a pull tab is attached to, or formed integrally with, each tear strip defined by the lines of weakness to assist removal of the tear strip. Suitably, a release coating such as a silicone or a fluoropolymer coating may be provided on the underside of the tear-off strips of the apertured wound contacting layer to assist removal of the strips.

The silicone coating on the wound facing side of the apertured layer is suitably a hydrophobic, tacky or non-tacky silicone polymer. The silicone elastomer coating is suitably coated only on the wound facing side of the apertured layer.

The total coating weight of the silicone is suitably from about 15 g/m² to about 500 g/m², for example from about 40 g/m² to about 250 g/m², typically from about 50 g/m² to about 150 g/m². The silicone is suitably a soft skin adhesive silicone composition. Suitable chemistry is described below. The silicone is suitably hydrophobic.

Suitably, the silicone composition is a so-called soft skin adhesive silicone elastomer. Such silicones can be made by an addition reaction (hydrosilylation) between (a) a vinyl functional polydimethyl siloxane, such as bis-dimethyl vinyl polydimethylsiloxane (PDMS), and (b) a hydrogen functional siloxane, such as dimethyl, methylhydrogen siloxane copolymers, hydrogen dimethylsiloxy terminated PDMS. The cure reaction is catalyzed by a hydrosilylation catalyst, such as a noble metal catalyst, suitably a platinum catalyst. A silicone prepolymer composition may further comprise a polymerization inhibitor that is evaporated from said composition during said step of thermally partially curing, for example 2-methyl-3-butyn-2-ol. Where present, the polymerization inhibitor is suitably present in an amount of from about 0.001 wt. % to about 1 wt. %, for example from about 0.01 wt. % to about 0.1 wt. % before curing. Alternatively, no polymerisation inhibitor is present in the silicone compositions.

Silicone skin adhesive compositions are suitably supplied as two-part systems: Part A contains at least the vinyl prepolymer and the catalyst, while Part B contains the vinyl prepolymer and the SiH siloxane cross linker. The compo-

nents are mixed immediately before use, optionally with addition of a polymerization inhibitor.

In embodiments, the silicone coating composition comprises or consists essentially of the following components: (A) a diorganopolysiloxane having at least 2 alkenyl groups in each molecule;

(B) an organohydrogenpolysiloxane having at least 2 silicon-bonded hydrogen atoms in each molecule, in a quantity sufficient for the ratio between the number of moles of silicon-bonded hydrogen atoms in this component and the number of moles of alkenyl groups in component (A) to have a value of from about 0.6:1 to about 20:1.

(C) optionally a platinum group metal catalyst suitably in a quantity providing 0.1 to 500 weight parts as platinum group metal per 1,000,000 weight parts component (A); and

(D) optionally, a volatile polymerization inhibitor, suitably selected from: alkyne alcohols such as 2-methyl-3-butyn-2-ol, 3,5-dimethyl-1-hexyn-3-ol, and phenylbutynol; ene-yne compounds such as 3-methyl-3-penten-1-yne and 3,5-dimethyl-3-hexen-1-yne; tetramethyltetrahexenyl-cyclotetrasiloxane; and benzotriazole.

The diorganopolysiloxane, component (A), used in the instant invention is the base component of the total composition. This diorganopolysiloxane must contain at least 2 alkenyl groups in each molecule in order for this composition to cure into a rubbery elastic silicone rubber coating composition.

The diorganopolysiloxane (A) comprises essentially straight-chain organopolysiloxane with the average unit formula $R_nSiO_{(4-n)/2}$, wherein R is selected from substituted and unsubstituted monovalent hydrocarbon groups and n has a value of 1.9 to 2.1 R may be exemplified by alkyl groups such as methyl, ethyl, propyl, and others; alkenyl groups such as vinyl, allyl, and others; aryl groups such as phenyl, and others; and haloalkyl groups such as 3,3,3-trifluoropropyl and others. The diorganopolysiloxane (A) should have a viscosity at 25° C. of at least 100 centipoise (1 d Pa·s). When such factors as the strength of the silicone rubber coating membrane, and blendability are taken into account, the viscosity of diorganopolysiloxane (A) at 25° C. is preferably from 1,000 centipoise (1 Pa·s) to 100,000 centipoise (100 Pa·s). The diorganopolysiloxane (A) may be exemplified by dimethylvinylsiloxy-endblocked dimethylpolysiloxanes, dimethylvinylsiloxy-endblocked dimethylsiloxane-methylvinylsiloxane copolymers, and dimethylvinyl-siloxy-endblocked dimethylsiloxane-methylphenylsiloxane copolymers.

Component (B), an organopolysiloxane that contains at least 2 silicon-bonded hydrogen atoms in each molecule, is a crosslinker for the composition of the instant invention. The organopolysiloxane (B) may be exemplified by trimethylsiloxy-endblocked methylhydrogenpolysiloxanes, trimethylsiloxy-endblocked dimethylsiloxanemethylhydrogensiloxane copolymers, dimethylphenylsiloxy-endblocked methylphenylsiloxanemethylhydrogensiloxane copolymers, cyclic methylhydrogenpolysiloxanes, and copolymers that contain the dimethylhydrogensiloxy unit and SiO₄/2 unit. The organohydrogenpolysiloxane (B) should be added in a quantity that the ratio between the number of moles of silicon-bonded hydrogen atoms in this organohydrogenpolysiloxane and the number of moles of alkenyl groups in component (A) has a value of 0.6:1 to 20:1.

The platinum group metal catalyst, component (C), used in the compositions is a curing catalyst. The platinum group metal catalyst (C) may be exemplified by platinum micro-powder, platinum black, chloroplatinic acid, platinum tetrachloride, olefin complexes of chloroplatinic acid, alcohol

solutions of chloroplatinic acid, complexes between chloroplatinic acid and alkenylsiloxanes, rhodium compounds, and palladium compounds. The platinum group metal catalyst (C) should be added generally at 0.1 to 500 weight parts as platinum group metal per 1,000,000 weight parts component (A), and is preferably used at 1 to 50 weight parts as platinum group metal per 1,000,000 weight parts component (A). The reaction will not develop adequately at less than 0.1 weight parts, while additions in excess of 500 weight parts are uneconomical.

The coated substrate is then subjected to thermal curing to at least partially cure the silicone. The thermal curing is suitably performed continuously by passing the coated substrate through an oven. Suitable thermal curing conditions include exposure to a temperature of from about 80° C. to about 200° C., for example about 120° C. to about 180° C. for a time of from about 1 minute to about 10 minutes, for example about 1.5 minutes to about 5 minutes. The elevated temperature results in evaporation of any polymerization inhibitor from the silicone composition and therefore promotes polymerization of the silicone. The resulting material is chemically polymerized, but may be capable of further curing by ionizing radiation for example during sterilization.

The adhesive dressing according to the present invention may further comprise at least one removable cover sheet to cover the absorbent island and the adhesive-coated margin(s) around the absorbent island. The cover sheet covers and protects the absorbent island and prevents premature adhesion of the adhesive layer. The cover sheet is removed by the care giver immediately before application of the dressing.

The cover sheet may comprise a film of polyethylene, polypropylene or fluorocarbons and papers coated with these materials. Suitably, the cover sheet is a release-coated paper sheet, such as a silicone, release-coated paper sheet. Examples of silicone-coated release papers are POLYSLIK (Registered Trade Mark) supplied by H.P. Smith & Co., offered in various formulations to control the degree of adhesion of the paper to the adhesive surface.

Suitably, the dressing comprises a first removable cover sheet having a first edge and a second removable cover sheet that meets the first cover sheet along the first edge.

Certain suitable dressings have a central cover sheet with first and second opposed edges, and two side cover sheets that meet the central cover sheet along the opposed edges. Suitably, the opposed edges are substantially parallel. This arrangement of three cover sheets is especially suitable for positioning of relatively large dressings, such as sacral dressings, as described in detail in EP-A-0117632.

Suitably, along each of said edges where the cover sheets meet, one of the cover sheets is folded back to provide a folded-back margin, and the other cover sheet overlaps the said folded-back margin. This provides an easy-to-grasp margin on each cover sheet in the region of overlap to assist removal of the cover sheets by the care giver.

In the case of the embodiment comprising three cover sheets described above, each side cover sheet is suitably folded back along each of said edges where the cover sheets meet to provide a folded-back margin, and the central cover sheet overlaps the said folded-back margin, suitably as described in EP-A-0117632.

Suitably the dressing according to the present invention is sterile and packaged in a microorganism-impermeable container.

The dressing of the invention may be made by conventional cutting and lamination of the various layers. The apertured coated top sheet may be made by coating a suitable film substrate with a fluid silicone precursor mixture

as described above, followed by thermal curing as described above. The coating may be done by any conventional means, such as by roller, doctor blade, spraying or dipping. In embodiments, the fluid silicone precursor may be coated onto an already-apertured substrate, in which case the coated substrate is suitably passed over an air blower to blow excess precursor out of the apertures as described for example in WO-A-9319709.

In other embodiments, the film substrate may be apertured, for example by die cutting, for example after the coating and curing steps. In a particularly suitable embodiment, the die cutting is performed after curing of a layer of the silicone sandwiched between the support film and a release sheet.

Accordingly, in a further aspect the present invention provides a method of making a wound dressing as described herein comprising the steps of forming a precursor laminate comprising a layer of silicone sandwiched between a polymeric film support sheet and a release sheet; die cutting aperture perimeters through the polymeric film support sheet and the silicone layer; and removing the release sheet to leave an apertured wound facing layer comprising an apertured polymeric film having a coating of a silicone gel on the wound facing surface thereof.

In a further aspect the present invention provides a method of making a wound dressing as described herein comprising the steps of: forming a precursor laminate comprising a layer of a fluid silicone prepolymer sandwiched between a polymeric film support sheet and a release sheet; curing said fluid silicone prepolymer; die cutting aperture perimeters through the polymeric film support sheet and the silicone layer; and removing the release sheet to leave an apertured wound facing layer comprising an apertured polymeric film having a coating of a silicone gel on the wound facing surface thereof.

In a further aspect the present invention provides a method of making a wound dressing as described herein comprising the steps of: forming a precursor laminate comprising a layer of silicone sandwiched between a polymeric film support sheet and a release sheet, wherein said precursor laminate is formed by disposing a layer of a fluid silicone prepolymer on said release sheet, curing said fluid silicone prepolymer, and disposing said polymeric film support sheet on the silicone layer; die cutting aperture perimeters through the polymeric film support sheet and the silicone layer; and removing the release sheet to leave an apertured wound facing layer comprising an apertured polymeric film having a coating of a silicone gel on the wound facing surface thereof.

Suitably, the method according to the present invention further comprises one or more of the following steps: coating one surface of a backing sheet with a layer of pressure sensitive adhesive; applying an island of absorbent material to a central region of the adhesive-coated surface of the backing sheet, wherein the absorbent material has a smaller area than the backing sheet so as to leave an adhesive-coated margin of the backing sheet around the island; and applying said apertured wound facing layer over said island with said polymeric film support sheet facing the backing sheet, wherein a margin of said wound contacting laminate is adhered to said adhesive-coated margin around said island.

Suitably, the method further comprises the step of packaging the dressing in a microorganism-impermeable container, and sterilizing the dressing. Sterilization may be, and preferably is, effected using an ethylene oxide (EtO) sterilization process, which is known in the art for sterilization of

medical and pharmaceutical products that cannot support conventional high temperature steam sterilization in a typical process, gaseous EtO is mixed with air at a ratio of at least 3% EtO and infiltrates the dressing to kill any microorganisms remaining from the production process. Most EtO sterilization processes involve a pre-conditioning stage, a sterilization stage and a degassing stage.

Sterilization may also be effected with ionizing radiation, such as gamma radiation. Commercially available gamma irradiation equipment includes equipment often used for gamma irradiation sterilization of products for medical applications. Cobalt 60 sources are appropriate. Total absorbed doses are suitably from 20 to 60 kGy, more suitably from about 35 to 50 kGy and dose rates are suitably about 7 to 8 kGy/hour. It has been found that the ionizing radiation provides a further benefit of further curing the silicone elastomer.

The methods of the invention may be used to make any products according to the invention. Any feature disclosed herein in relation to any one or more aspects of the invention is suitable for use in any of the other aspects defined herein.

Embodiments of the present invention will now be described by way of example with reference to the accompanying drawings, in which:

FIG. 1 shows a longitudinal cross-section through a dressing according to the invention;

FIG. 2 shows a perspective view of the apertured top sheet of the dressing of FIG. 1;

FIG. 3 shows a bottom perspective view of a dressing according to FIG. 1, partially cut away to show detail;

FIG. 4 shows a bottom perspective view of a dressing according to FIG. 1 further comprising a cover sheet;

FIG. 5 shows the dressing of FIG. 3 enclosed in a microorganism-impermeable pouch;

FIG. 6 shows a perspective view of an apertured top sheet incorporating tear strips;

FIG. 7 shows a bottom perspective view of a dressing according to a second embodiment of the present invention, incorporating the apertured top sheet of FIG. 6, and

FIG. 8 shows a schematic view of a method according to the invention of making the silicone-coated apertured top sheet.

Referring to FIGS. 1 to 4, the wound dressing 1 according to the invention comprises a conventional backing sheet 2 of microporous, semipermeable polyurethane. The backing sheet 2 is coated on its wound-facing surface with a continuous layer 4 of medically acceptable acrylic pressure-sensitive adhesive. An absorbent island is located in the central region of the wound-facing surface of the backing sheet 2 so as to leave an adhesive-coated margin of the backing sheet 2 around the island. The absorbent island is made up of nonwoven textile absorbent/wicking layer 6 and a polyurethane foam wound facing layer 8. Each of these layers is 1-2 mm thick in the dry uncompressed state, i.e. before use. The absorbent/wicking layer 6 is formed of viscose fibers optionally mixed with gel-forming fibers or other superabsorbents. The polyurethane foam layer is formed of a hydrophilic polyurethane foam available from Systagenix Wound Management Ltd. under the Registered Trade mark TIELLE. It is produced as described in EP-A-0541391.

The dressing 1 further comprises an apertured wound-facing top sheet 10 that covers the absorbent island and extends around the edges of the absorbent island so that it adheres to the margins of the adhesive-coated backing sheet around the absorbent island. The top sheet 10 is smaller than

the backing sheet **2**, whereby a relatively narrow adhesive-coated margin **12** of the backing sheet extends around all edges of the top sheet **10**.

The top sheet **10** is formed from an apertured film substrate **14** coated on its wound facing surface with a laser 5 of silicone elastomer **16**. The film substrate is formed of polyurethane, has thickness about 10 μm . The circular apertures of diameter 6 mm are arranged in a regular array at 10,000 apertures per m^2 such that the open area of the film substrate is about 28%. The thickness/coating weight of the silicone is about 50 g/m^2 . The resulting overall thickness of the top sheet is about 80 μm . The relatively large aperture size and low thickness of the top sheet **10** enable pressure-sensitive adhesive from the laser **4** to penetrate through the apertures and adhere to skin located below the top sheet **10**. 15 The degree of adherency can be controlled by varying the tackiness of the silicone elastomer, the size of the apertures, and the overall open area of the top sheet, thereby allowing optimization of adherency for leak prevention and secure attachment versus ease of removal and repositionability. In this embodiment, the additional narrow adhesive margin **16** around the top sheet is provided for further leak prevention from the dressing. In other embodiments, the top sheet may be conterminous with the backing sheet so that there is no narrow adhesive margin **16**.

Referring to FIG. **3**, release-coated cover sheets **20,22** are positioned over the wound facing side of the dressing. Inside edges **24,26** of the cover sheets **20,22** are folded over to provide for easy removal of the cover sheets before application of the dressing.

Referring to FIG. **4**, the wound dressing of FIG. **3** is shown sterile and packaged in a microorganism-impermeable envelope **30** having a transparent window **32**.

Referring to FIG. **5**, this embodiment **40** of the apertured wound facing sheet consists of an apertured polymer film substrate layer **42** and silicone coating layer **44** as described above in relation to the first embodiment. Lines of perforations **45,46,47,48** are formed in the film substrate laser **42** parallel to the four edges of the wound facing sheet, to define respective tear stops along each edge. Respective pull tabs **51,52,53,54** are formed integrally with the film substrate layer for removal of the tear strips. A release coating of non-adherent silicone or fluoropolymer may be provided on the surface of the tear strips, opposite the silicone-coated wound facing surface to assist removal of the tear strips in use, as described below.

Referring to FIG. **6**, the wound dressing **60** according to this embodiment comprises a PSA coated backing sheet **62**, and absorbent island **64**, and release-coated cover sheets **65,66** as described above in relation to the first embodiment. The apertured wound facing sheet **40** as shown in FIG. **5** completely covers the backing sheet **62**. The dressing may be used in this configuration by removing the cover sheets **65,66** and applying the dressing around a wound. The PSA-coated margin of the backing sheet **62** is completely 45 covered by the apertured wound facing sheet, whereby the overall adherence of the margin is reduced to allow easy removal and/or repositioning of the dressing. For wounds requiring stronger adherency, the tear strips on the apertured wound facing layer may be removed by pulling on the tabs **50,51,52,53** to expose a margin of the PSA coated backing sheet extending around the apertured wound facing sheet.

Referring to FIG. **8**, the steps in the preparation of the apertured wound facing sheet according to this embodiment start from a release sheet **80** of a polymeric film material. 65 This is coated with a layer **82** of the fluid silicone precursor composition as described below. The coating may be done

by any conventional means such as spraying, roller and/or doctor blade. A layer **84** of the substrate film material is then laminated over the fluid silicone layer. The laminate is then heated to thermally cure the silicone elastomer by passing through an oven held at 150° C. Typical conditions are 5 passes at 4.2 m/min, total residence time 1.5 minutes. This results in thermal partial cure of the silicone coating. The material is then allowed to cool. The resulting cured laminate passes through a die cutter that makes circular cuts **86** through the substrate film material **84** and the cured silicone layer **88**, but not through the release sheet **80**. The release sheet **80** is then peeled from the silicone layer to separate the apertured coated substrate **90** from the release sheet **80**. The silicone and support film from the apertures adheres to the release sheet and is removed with the release sheet **80**. 10 The silicone coating composition is prepared by mixing Components A and B of a soft silicone skin adhesive silicone elastomer kit supplied by Dow Corning under product reference Q7-9177. The components are mixed in weight ratio 50:50. Component A comprises a bis-dimethylvinyl terminated polydimethylsiloxane and a platinum catalyst. Component B composes a bis-hydride terminated polydimethylsiloxane. To the mixture is added 2-methyl-3-butyn-2-ol inhibitor at a concentration of 0.02 wt %.

Alternatively, and again with reference to FIG. **8**, the release sheet **80** of a polymeric film material is coated with a layer **82** of the fluid silicone precursor composition by any conventional means such as spraying, roller and/or doctor blade and the coated film is then heated to thermally cure the silicone elastomer by passing through an oven held at 150° C. Typical conditions are 1 pass at 0.8 m/min, total residence time 1.5 minutes. This results in thermal cure of the silicone coating. Layer **84** of the substrate film material is then laminated over the silicone layer. The material is then allowed to cool. The resulting cured laminate passes through a die cutter that makes circular cuts **86** through the substrate film material **84** and the cured silicone layer **88**, but not through the release sheet **80**. The release sheet **80** is then peeled from the silicone layer to separate the apertured coated substrate **90** from the release sheet **80**. The silicone and support film from the apertures adheres to the release sheet and is removed with the release sheet **80**. The silicone coating composition is prepared by mixing Components A and B of a soft silicone skin adhesive silicone elastomer kit supplied by Dow Corning under product reference Q7-9177. The components are mixed in weight ratio 50:50. Component A comprises a bis-dimethylvinyl terminated polydimethylsiloxane and a platinum catalyst. Component B comprises a bis-hydride terminated polydimethylsiloxane.

The above embodiments have been described by way of example only. It is understood that many other embodiments falling within the scope of the accompanying claims will be apparent to the skilled reader. All publications, patents, and patent applications cited herein are hereby incorporated by reference in their entirety for all purposes.

The invention claimed is:

1. A wound dressing comprising:

- a backing sheet;
- an island of absorbent material on a central region of the backing sheet;
- a pressure-sensitive adhesive disposed between the backing sheet and the island and coupling the island to the backing sheet, and on at least a portion of the backing sheet around the island; and
- an apertured layer having at least two apertures and a wound-facing side coated with a silicone elastomer;

11

wherein the apertured layer is adhered to the backing sheet by the pressure-sensitive adhesive and is configured to allow a portion of the pressure-sensitive adhesive through the apertures to contact skin of a user when the wound dressing is applied to the user; and wherein the apertured layer comprises lines of weakness substantially parallel to, and spaced from, one or more edges of the apertured layer defining a tear-off strip or strips along one or more edges of the apertured layer.

2. The wound dressing according to claim 1, wherein the apertured layer comprises apertures positioned substantially in a uniform array.

3. The wound dressing according to claim 1, wherein a thickness of the apertured layer is less than 1 mm.

4. The wound dressing according to claim 1, wherein the apertured layer further comprises an apertured substrate.

5. The wound dressing according to claim 4, wherein the silicone elastomer is coated on a first side of the apertured substrate.

6. The wound dressing according to claim 4, wherein the apertured substrate is an apertured film.

7. The wound dressing according to claim 1, further comprising:

a margin of the pressure-sensitive adhesive around the island of absorbent material;

wherein the island of absorbent material is positioned between the backing sheet and the apertured layer.

8. The wound dressing according to claim 7, wherein the island of absorbent material comprises an absorbent layer and a polyurethane foam layer.

9. The wound dressing according to claim 8, wherein the absorbent layer comprises a nonwoven textile formed of viscose fibers mixed with gel-forming fibers.

10. The wound dressing according to claim 8, wherein the polyurethane foam layer comprises a hydrophilic polyurethane foam.

11. The wound dressing according to claim 7, wherein the margin of the pressure-sensitive adhesive extends around the apertured layer to form an adhesive-coated border.

12. The wound dressing according to claim 11, wherein a portion of the margin of the pressure-sensitive adhesive covered by the apertured layer has a mean width of from 5 mm to 30 mm, and the adhesive-coated border has a mean width of from 2 mm to 20 mm.

13. The wound dressing according to claim 1, wherein a pull tab is attached to, or formed integrally with, each of the tear-off strip or strips to assist removal of the tear-off strip or strips.

14. The wound dressing according to claim 1, wherein the silicone elastomer is a hydrophobic silicone polymer.

15. The wound dressing according to claim 1, wherein the apertured layer comprises an open area of from 5% to 75% of a total area of the apertured layer.

12

16. The wound dressing according to claim 1, wherein the apertured layer comprises apertures having an open area of from 2 mm² to 100 mm².

17. The wound dressing according to claim 15, wherein the apertured layer comprises apertures of which at least about 90% have an open area of from 5 mm² to 50 mm².

18. A wound dressing comprising an apertured layer comprising an apertured polymeric film support layer and a coating of silicone elastomer disposed on a first surface of the apertured polymeric film support layer, and wherein the apertured layer comprises a line or lines of weakness substantially parallel to, and spaced from, one or more edges of the apertured layer defining a tear-off strip or strips along one or more edges of the apertured layer, wherein the tear-off strip or strips comprise a release coating on a second surface of the aperture layer opposite the first surface of the aperture layer, wherein the apertured layer comprises apertures having an open area of from 2 mm² to 100 mm².

19. The wound dressing of claim 18, wherein the apertured layer further comprises apertures positioned substantially in a uniform array.

20. The wound dressing of claim 18, wherein a thickness of the apertured layer is less than about 1 mm.

21. The wound dressing of claim 18, wherein a thickness of the apertured layer is between 0.02 mm and 0.5 mm.

22. The wound dressing of claim 18, further comprising:

a backing sheet;

a layer of pressure-sensitive adhesive disposed on at least a portion of the backing sheet; and

an island of absorbent material having a smaller area than the backing sheet;

wherein the backing sheet comprises a margin of the pressure-sensitive adhesive around the island of absorbent material;

wherein the island of absorbent material is positioned between the backing sheet and the apertured layer.

23. The wound dressing of claim 22, wherein the island of absorbent material comprises an absorbent layer and a polyurethane foam layer.

24. The wound dressing of claim 23, wherein the absorbent layer comprises a nonwoven textile formed of viscose fibers mixed with gel-forming fibers.

25. The wound dressing of claim 23, wherein the polyurethane foam layer comprises a hydrophilic polyurethane foam.

26. The wound dressing according to claim 18, wherein a pull tab is attached to, or formed integrally with, each of the tear-off strip or strips to assist removal of the tear-off strip or strips.

27. The wound dressing according to claim 18, wherein an open area of the apertured layer is from 5% to 75% of a total area of the apertured layer.

* * * * *