

(12) STANDARD PATENT
(19) AUSTRALIAN PATENT OFFICE

(11) Application No. **AU 2017336305 B2**

(54) Title
Negative pressure wound treatment apparatuses and methods with integrated electronics

(51) International Patent Classification(s)
A61M 1/00 (2006.01)

(21) Application No: **2017336305** (22) Date of Filing: **2017.09.29**

(87) WIPO No: **WO18/060412**

(30) Priority Data

(31) Number	(32) Date	(33) Country
62/402,298	2016.09.30	US
62/402,382	2016.09.30	US
62/402,146	2016.09.30	US

(43) Publication Date: **2018.04.05**

(44) Accepted Journal Date: **2023.01.19**

(71) Applicant(s)
Smith & Nephew plc

(72) Inventor(s)
Beadle, Victoria;Hesketh, Mark;Kelbie, William;Musgrave, Damyn;Robinson, Joseph William;Steward, Daniel

(74) Agent / Attorney
Griffith Hack, Level 10 161 Collins St, MELBOURNE, VIC, 3000, AU

(56) Related Art
US 2015/0174304 A1
US 2015/0065965 A1
US 2016/0270967 A1
WO 2016/174048 A1
WO 2017/186771 A1



(51) International Patent Classification:
A61M 1/00 (2006.01)

(21) International Application Number:
PCT/EP2017/074755

(22) International Filing Date:
29 September 2017 (29.09.2017)

(25) Filing Language: English

(26) Publication Language: English

(30) Priority Data:
62/402,382 30 September 2016 (30.09.2016) US
62/402,298 30 September 2016 (30.09.2016) US
62/402,146 30 September 2016 (30.09.2016) US

(71) Applicant: SMITH & NEPHEW PLC [GB/GB]; 15 Adam Street, London WC2N 6LA (GB).

(72) Inventors: BEADLE, Victoria; Smith & Nephew Wound Management 101 Hessle Road, Hull HU3 2BN (GB). HESKETH, Mark; PA Consulting Services Limited Back Lane, Melbourn Hertfordshire SG8 6DP (GB). KEL-

BIE, William; Smith & Nephew Wound Management 101 Hessle Road, Hull HU3 2BN (GB). MUSGRAVE, Damyn; PA Consulting Services Limited Back Lane, Melbourn Hertfordshire SG8 6DP (GB). ROBINSON, Joseph, William; PA Consulting Services Limited Back Lane, Melbourn Hertfordshire SG8 6DP (GB). STEWARD, Daniel; Smith & Nephew Wound Management 101 Hessle Road, Hull HU3 2BN (GB).

(74) Agent: HINES, Adam; 101 Hessle Road, Hull East Yorkshire HU3 2BN (GB).

(81) Designated States (unless otherwise indicated, for every kind of national protection available): AE, AG, AL, AM, AO, AT, AU, AZ, BA, BB, BG, BH, BN, BR, BW, BY, BZ, CA, CH, CL, CN, CO, CR, CU, CZ, DE, DJ, DK, DM, DO, DZ, EC, EE, EG, ES, FI, GB, GD, GE, GH, GM, GT, HN, HR, HU, ID, IL, IN, IR, IS, JO, JP, KE, KG, KH, KN, KP, KR, KW, KZ, LA, LC, LK, LR, LS, LU, LY, MA, MD, ME, MG, MK, MN, MW, MX, MY, MZ, NA, NG, NI, NO, NZ, OM, PA, PE, PG, PH, PL, PT, QA, RO, RS, RU, RW, SA,

(54) Title: NEGATIVE PRESSURE WOUND TREATMENT APPARATUSES AND METHODS WITH INTEGRATED ELECTRONICS

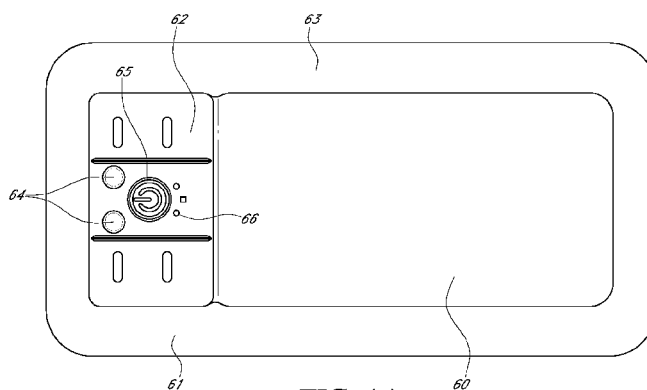

FIG. 1A

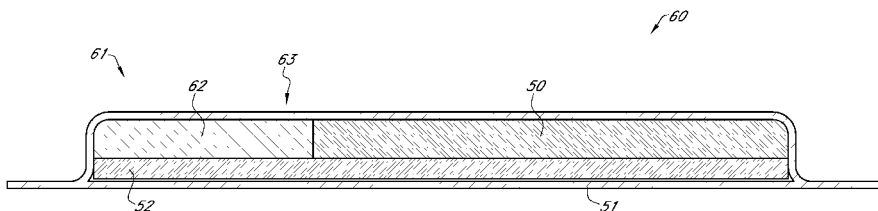

FIG. 1B

(57) Abstract: Disclosed embodiments relate to apparatuses and methods for wound treatment. In some embodiments, a wound dressing apparatus can comprise a wound contact layer, a first area and a second area over the wound contact layer, and a cover layer configured to cover the wound contact layer, the first area, and the second area. The first area can comprise a spacer layer and an absorbent layer over the spacer layer. The second area can comprise an electronics cassette or cradle comprising a negative pressure source and/or electronic components.



SC, SD, SE, SG, SK, SL, SM, ST, SV, SY, TH, TJ, TM, TN,
TR, TT, TZ, UA, UG, US, UZ, VC, VN, ZA, ZM, ZW.

(84) Designated States (*unless otherwise indicated, for every kind of regional protection available*): ARIPO (BW, GH, GM, KE, LR, LS, MW, MZ, NA, RW, SD, SL, ST, SZ, TZ, UG, ZM, ZW), Eurasian (AM, AZ, BY, KG, KZ, RU, TJ, TM), European (AL, AT, BE, BG, CH, CY, CZ, DE, DK, EE, ES, FI, FR, GB, GR, HR, HU, IE, IS, IT, LT, LU, LV, MC, MK, MT, NL, NO, PL, PT, RO, RS, SE, SI, SK, SM, TR), OAPI (BF, BJ, CF, CG, CI, CM, GA, GN, GQ, GW, KM, ML, MR, NE, SN, TD, TG).

Published:

— *with international search report (Art. 21(3))*

**NEGATIVE PRESSURE WOUND TREATMENT APPARATUSES AND METHODS WITH
INTEGRATED ELECTRONICS**

CROSS-REFERENCE TO RELATED APPLICATIONS

[0001] This application claims priority to U.S. Provisional Patent Application No. 62/402146, filed on September 30, 2016, U.S. Provisional Patent Application No. 62/402298, filed September 30, 2016, and U.S. Provisional Patent Application No. 62/402382, filed on September 30, 2016. All of these applications are hereby incorporated by reference in their entireties and made part of this disclosure.

BACKGROUND

Technical Field

[0002] Embodiments described herein relate to apparatuses, systems, and methods the treatment of wounds, for example using dressings in combination with negative pressure wound therapy.

Description of the Related Art

[0003] The treatment of open or chronic wounds that are too large to spontaneously close or otherwise fail to heal by means of applying negative pressure to the site of the wound is well known in the art. Negative pressure wound therapy (NPWT) systems currently known in the art commonly involve placing a cover that is impermeable or semi-permeable to fluids over the wound, using various means to seal the cover to the tissue of the patient surrounding the wound, and connecting a source of negative pressure (such as a vacuum pump) to the cover in a manner so that negative pressure is created and maintained under the cover. It is believed that such negative pressures promote wound healing by facilitating the formation of granulation tissue at the wound site and assisting the body's normal inflammatory process while simultaneously removing excess fluid, which may contain adverse cytokines and/or bacteria. However, further improvements in NPWT are needed to fully realize the benefits of treatment.

[0004] Many different types of wound dressings are known for aiding in NPWT systems. These different types of wound dressings include many different types of materials and layers, for example, gauze, pads, foam pads or multi-layer wound dressings. One example

of a multi-layer wound dressing is the PICO dressing, available from Smith & Nephew, which includes a superabsorbent layer beneath a backing layer to provide a canister-less system for treating a wound with NPWT. The wound dressing may be sealed to a suction port providing connection to a length of tubing, which may be used to pump fluid out of the dressing and/or to transmit negative pressure from a pump to the wound dressing.

[0005] Prior art dressings for use in negative pressure such as those described above have included a negative pressure source located in a remote location from the wound dressing. Negative pressure sources located remote from the wound dressing have to be held by or attached to the user or other pump support mechanism. Additionally, a tubing or connector is required to connect the remote negative pressure source to the wound dressing. The remote pump and tubing can be cumbersome and difficult to hide in or attach to patient clothing. Depending on the location of the wound dressing, it can be difficult to comfortably and conveniently position the remote pump and tubing. When used, wound exudate may soak into the dressing, and the moisture from the wound has made it difficult to incorporate electronic components into the dressing.

SUMMARY

[0006] Embodiments of the present disclosure relate to apparatuses and methods for wound treatment. Some of the wound treatment apparatuses described herein comprise a negative pressure source or a pump system for providing negative pressure to a wound. Wound treatment apparatuses may also comprise wound dressings that may be used in combination with the negative pressure sources and pump assemblies described herein.

[0007] In some embodiments, a negative pressure source is incorporated into a wound dressing apparatus so that the wound dressing and the negative pressure source are part of an integral or integrated wound dressing structure that applies the wound dressing and the negative pressure source simultaneously to a patient's wound. The negative pressure source and/or electronic components may be positioned between a wound contact layer and a cover layer of the wound dressing. An electronics assembly can be incorporated into the absorbent material of the dressing and maintain conformability of the dressing. These and other embodiments as described herein are directed to overcoming particular challenges involved with incorporating a negative pressure source and/or electronic components into a wound dressing.

[0008] In a first aspect, the invention provides a wound dressing apparatus, comprising: a wound contact layer configured to be positioned in contact with a wound; a first area over the wound contact layer comprising: a spacer layer; and an absorbent layer over the spacer layer; a second area over the wound contact layer comprising an electronics cassette, the electronics cassette comprising at least one of a negative pressure source and electronic components surrounded by a casing, wherein the first area is positioned adjacent to the second area, wherein the casing is configured to surround at least one of the negative pressure source and the electronic components and to allow fluid communication between the first area and second area; and a cover layer configured to cover and form a seal over the wound contact layer, the first area, and the second area, wherein the electronic components are encapsulated in a hydrophobic coating and wherein the wound dressing apparatus further comprises a negative pressure source inlet protection mechanism and a negative pressure source outlet.

[0009] The wound dressing apparatus of the preceding paragraph or in other embodiments can include one or more of the following features. The electronic components can comprise one or more of a power source, a flexible circuit board, a sensor, a switch, and/or a light or LED indicator. The negative pressure source outlet may be a negative pressure source exhaust. The negative pressure source outlet or the negative pressure source exhaust can comprise an antibacterial membrane and/or a non-return valve. The cover layer can comprise an aperture over the outlet or exhaust. The negative pressure source inlet protection mechanism can comprise a hydrophobic material configured to prevent fluid from entering the negative pressure source. The electronics cassette can comprise one or more slits, grooves or recesses in the casing, wherein the slits, grooves or recesses are configured to provide one or more hinge points in the casing and increase flexibility of the electronics cassette. The spacer layer can extend within both the first area and the second area and the electronics cassette is provided over the spacer layer. The negative pressure source can be encapsulated in a hydrophobic coating.

[0010] According to another embodiment, a wound dressing apparatus can comprise a wound contact layer configured to be positioned in contact with a wound, a first area over the wound contact layer can comprise a spacer layer and an absorbent layer over the spacer layer, a second area over the wound contact layer comprising an electronics unit, the electronics unit comprising a negative pressure source and/or electronic components, wherein the first area is positioned adjacent to the second area, wherein the second area can comprise a

cradle configured to allow fluid communication between the first area and second area, wherein the cradle can comprise recesses configured to receive a portion of the electronics unit, and a cover layer configured to cover and form a seal over the wound contact layer, the first area, and the second area.

[0011] The wound dressing apparatus of the preceding paragraph or in other embodiments can include one or more of the following features. The cradle can comprise a hydrophilic material. The wound dressing apparatus wherein at least a portion of the second area can overlap a portion of the first area. The cradle can comprise a recess configured to receive a portion of the absorbent layer. The electronic components can comprise one or more of a power source, a flexible circuit board, a sensor, a switch, and/or a light or LED indicator. The wound dressing apparatus can further comprise a negative pressure source inlet protection mechanism and a negative pressure source outlet or exhaust. The negative pressure source outlet or exhaust can comprise an antibacterial membrane and/or a non-return valve. The cover layer can comprise an aperture over the outlet or exhaust. The negative pressure source inlet protection mechanism can comprise a hydrophobic material configured to prevent fluid from entering the negative pressure source. The negative pressure source and/or electronic components can be encapsulated in a hydrophobic coating.

[0012] According to another embodiment, a wound dressing apparatus can comprise a wound contact layer comprising a proximal wound-facing face and a distal face, wherein the wound-facing face is configured to be positioned in contact with a wound, a spacer layer comprising a proximal wound-facing face and a distal face, the spacer layer positioned over the distal face of the wound contact layer, a first area over the spacer layer comprising an absorbent layer, a second area over the spacer layer comprising an electronics unit, the electronics unit comprising a negative pressure source and/or electronic components, wherein the first area is positioned adjacent to the second area, wherein the second area over the spacer layer comprises a cradle configured to allow fluid communication between the first area and second area, wherein the cradle comprises recesses configured to receive the electronics unit, and a cover layer configured to cover and form a seal over the wound contact layer, the spacer layer, the first area, and the second area.

[0013] The wound dressing apparatus of the preceding paragraph or in other embodiments can include one or more of the following features. The cradle can comprise a hydrophilic material. The electronic components can comprise one or more of a power source,

a flexible circuit board, a sensor, a switch, and/or a light or LED indicator. The wound dressing apparatus can further comprise a negative pressure source inlet protection mechanism and a negative pressure source outlet or exhaust. The negative pressure source outlet or exhaust can comprise an antibacterial membrane and/or a non-return valve. The cover layer can comprise an aperture over the outlet or exhaust. The negative pressure source inlet protection mechanism can comprise a hydrophobic material configured to prevent fluid from entering the negative pressure source.

[0014] According to another embodiment, a wound dressing apparatus can comprise a wound contact layer comprising a proximal wound-facing face and a distal face, wherein the proximal wound-facing face is configured to be positioned in contact with a wound, a spacer layer comprising a proximal wound-facing face and a distal face, the spacer layer positioned over the distal face of the wound contact layer, an absorbent layer comprising a proximal wound-facing face and a distal face, the absorbent layer positioned on the distal face of the spacer layer, an electronics unit comprising a negative pressure source and/or electronic components, a cradle positioned on the distal face of the absorbent layer and configured to allow fluid communication between the absorbent layer and the electronics unit, wherein the cradle comprises recesses configured to receive the electronics unit, and a cover layer configured to cover and form a seal over the wound contact layer, the spacer layer, the absorbent layer, the cradle and electronics unit.

[0015] The wound dressing apparatus of the preceding paragraph or in other embodiments can include one or more of the following features. The cradle can comprise a hydrophilic material. The electronic components can comprise one or more of a power source, a flexible circuit board, a sensor, a switch, and/or a light or LED indicator. The wound dressing apparatus can further comprise a negative pressure source inlet protection mechanism and a negative pressure source outlet or exhaust. The negative pressure source outlet or exhaust can comprise an antibacterial membrane and/or a non-return valve. The cover layer can comprise an aperture over the outlet or exhaust. The negative pressure source inlet protection mechanism can comprise a hydrophobic material configured to prevent fluid from entering the negative pressure source.

[0016] According to another embodiment, a wound dressing apparatus can comprise a wound contact layer comprising a proximal wound-facing face and a distal face, wherein the wound-facing face is configured to be positioned in contact with a wound, a first

area over the distal face of the wound contact layer comprising a spacer layer, and an absorbent layer over the spacer layer, a second area over the distal face of the wound contact layer comprising an electronics unit, the electronics unit comprising a negative pressure source and/or electronic components, wherein the first area is positioned adjacent to the second area, wherein the second area comprises a cradle positioned directly on the wound contact layer, wherein the cradle is configured to allow fluid communication between the first area and second area, and wherein the cradle comprises recesses configured to receive the electronics unit, and a cover layer configured to cover and form a seal over the wound contact layer, the first area, and the second area.

[0017] The wound dressing apparatus of the preceding paragraph or in other embodiments can include one or more of the following features. The cradle can comprise a hydrophilic material. The electronic components can comprise one or more of a power source, a flexible circuit board, a sensor, a switch, and/or a light or LED indicator. The wound dressing apparatus can further comprise a negative pressure source inlet protection mechanism and a negative pressure source outlet or exhaust. The negative pressure source outlet or exhaust can comprise an antibacterial membrane and/or a non-return valve. The cover layer can comprise an aperture over the outlet or exhaust. The negative pressure source inlet protection mechanism can comprise a hydrophobic material configured to prevent fluid from entering the negative pressure source.

[0018] Any of the features, components, or details of any of the arrangements or embodiments disclosed in this application, including without limitation any of the pump embodiments and any of the negative pressure wound therapy embodiments disclosed below, are interchangeably combinable with any other features, components, or details of any of the arrangements or embodiments disclosed herein to form new arrangements and embodiments.

BRIEF DESCRIPTION OF THE DRAWINGS

[0019] Figures 1A-1B illustrates a wound dressing apparatus incorporating the pump and/or other electronic components within the wound dressing and offset from the absorbent layer;

[0020] Figures 2, 3A-3D, and 4A-4B illustrate embodiments of the electronics unit 67 that can be incorporated into a wound dressing;

[0021] Figures 5A-5E illustrate embodiments of components of the electronics cassette;

[0022] Figures 6A-6D illustrate an embodiment of the flexible circuit board for use in the electronics cassette;

[0023] Figures 7A-7D illustrate embodiments of electronic cassettes with two pump exhausts in various configurations and shapes;

[0024] Figures 8A-8C illustrates embodiments of electronic cassettes with one pump exhaust in various shapes;

[0025] Figures 9A-9D illustrate various embodiments of the electronic cassette with various configurations for components on the electronic cassettes;

[0026] Figure 10 illustrates an embodiment of the electronics cassette;

[0027] Figures 11-16 illustrate an assembly process for the electronics unit of the electronics cassette;

[0028] Figure 17 illustrates an embodiment of on/off switch for use with a wound dressing with integrated electronics;

[0029] Figure 18 illustrates an embodiment of a wound dressing incorporating an electronics unit within the dressing;

[0030] Figure 19A illustrates an embodiment of the electronics unit;

[0031] Figure 19B illustrates an embodiment of the cradle that can be within, adjacent to, and/or above the absorbent dressing material;

[0032] Figure 19C illustrates an embodiment of the electronics unit incorporated into the cradle;

[0033] Figures 20A-20B illustrate an embodiment of a wound dressing incorporating the electronics unit and electronics cradle adjacent to and at least partially overlapping the absorbent pad;

[0034] Figures 21A-21F illustrate an embodiment of a wound dressing incorporating an electronics unit resting in a cradle;

[0035] Figures 22A-22C illustrate another embodiment of a wound dressing incorporating an electronics unit and cradle in the wound dressing;

[0036] Figure 23 illustrates an absorbent layer provided over the entire length of the spacer layer;

[0037] Figure 24 illustrates an embodiment of a wound dressing incorporating an electronics unit resting in a cradle;

[0038] Figures 25A-25B illustrate embodiments of an assembled wound dressing with the dressing layers enclosed between a wound contact layer and a cover layer; and

[0039] Figure 26 illustrates an embodiment of an assembled wound dressing.

DETAILED DESCRIPTION

[0040] Embodiments disclosed herein relate to apparatuses and methods of treating a wound with reduced pressure, including a source of negative pressure and wound dressing components and apparatuses. The apparatuses and components comprising the wound overlay and packing materials, if any, are sometimes collectively referred to herein as dressings.

[0041] It will be appreciated that throughout this specification reference is made to a wound. It is to be understood that the term wound is to be broadly construed and encompasses open and closed wounds in which skin is torn, cut or punctured or where trauma causes a contusion, or any other superficial or other conditions or imperfections on the skin of a patient or otherwise that benefit from reduced pressure treatment. A wound is thus broadly defined as any damaged region of tissue where fluid may or may not be produced. Examples of such wounds include, but are not limited to, abdominal wounds or other large or incisional wounds, either as a result of surgery, trauma, sterniotomies, fasciotomies, or other conditions, dehisced wounds, acute wounds, chronic wounds, subacute and dehisced wounds, traumatic wounds, flaps and skin grafts, lacerations, abrasions, contusions, burns, diabetic ulcers, pressure ulcers, stoma, surgical wounds, trauma and venous ulcers or the like.

[0042] It will be understood that embodiments of the present disclosure are generally applicable to use in topical negative pressure ("TNP") therapy systems. Briefly, negative pressure wound therapy assists in the closure and healing of many forms of "hard to heal" wounds by reducing tissue oedema; encouraging blood flow and granular tissue formation; removing excess exudate and may reduce bacterial load (and thus infection risk). In addition, the therapy allows for less disturbance of a wound leading to more rapid healing. TNP therapy systems may also assist on the healing of surgically closed wounds by removing fluid and by helping to stabilize the tissue in the apposed position of closure. A further beneficial use of TNP therapy can be found in grafts and flaps where removal of excess fluid

is important and close proximity of the graft to tissue is required in order to ensure tissue viability.

[0043] As is used herein, reduced or negative pressure levels, such as -X mmHg, represent pressure levels relative to normal ambient atmospheric pressure, which can correspond to 760 mmHg (or 1 atm, 29.93 inHg, 101.325 kPa, 14.696 psi, etc.). Accordingly, a negative pressure value of -X mmHg reflects absolute pressure that is X mmHg below 760 mmHg or, in other words, an absolute pressure of (760-X) mmHg. In addition, negative pressure that is "less" or "smaller" than X mmHg corresponds to pressure that is closer to atmospheric pressure (e.g., -40 mmHg is less than -60 mmHg). Negative pressure that is "more" or "greater" than -X mmHg corresponds to pressure that is further from atmospheric pressure (e.g., -80 mmHg is more than -60 mmHg). In some embodiments, local ambient atmospheric pressure is used as a reference point, and such local atmospheric pressure may not necessarily be, for example, 760 mmHg.

[0044] The negative pressure range for some embodiments of the present disclosure can be approximately -80 mmHg, or between about -20 mmHg and -200 mmHg. Note that these pressures are relative to normal ambient atmospheric pressure, which can be 760 mmHg. Thus, -200 mmHg would be about 560 mmHg in practical terms. In some embodiments, the pressure range can be between about -40 mmHg and -150 mmHg. Alternatively a pressure range of up to -75 mmHg, up to -80 mmHg or over -80 mmHg can be used. Also in other embodiments a pressure range of below -75 mmHg can be used. Alternatively, a pressure range of over approximately -100 mmHg, or even -150 mmHg, can be supplied by the negative pressure apparatus.

[0045] In some embodiments of wound closure devices described herein, increased wound contraction can lead to increased tissue expansion in the surrounding wound tissue. This effect may be increased by varying the force applied to the tissue, for example by varying the negative pressure applied to the wound over time, possibly in conjunction with increased tensile forces applied to the wound via embodiments of the wound closure devices. In some embodiments, negative pressure may be varied over time for example using a sinusoidal wave, square wave, and/or in synchronization with one or more patient physiological indices (e.g., heartbeat). Examples of such applications where additional disclosure relating to the preceding may be found include U.S. Patent No. 8,235,955, titled "Wound treatment apparatus and method," issued on August 7, 2012; and U.S. Patent No. 7,753,894, titled "Wound cleansing

apparatus with stress," issued July 13, 2010. The disclosures of both of these patents are hereby incorporated by reference in their entirety.

[0046] International Application PCT/GB2012/000587, titled "WOUND DRESSING AND METHOD OF TREATMENT" and filed on July 12, 2012, and published as WO 2013/007973 A2 on January 17, 2013, is an application, hereby incorporated and considered to be part of this specification, that is directed to embodiments, methods of manufacture, and wound dressing components and wound treatment apparatuses that may be used in combination or in addition to the embodiments described herein. Additionally, embodiments of the wound dressings, wound treatment apparatuses and methods described herein may also be used in combination or in addition to those described in U.S. Provisional Application No. 61/650,904, filed May 23, 2012, titled "APPARATUSES AND METHODS FOR NEGATIVE PRESSURE WOUND THERAPY," International Application No. PCT/IB2013/001469, filed May 22, 2013, titled "APPARATUSES AND METHODS FOR NEGATIVE PRESSURE WOUND THERAPY," and published as WO 2013/175306 on November 28, 2013, US Patent Application No. 14/418874, filed January 30, 2015, published as U.S. Publication No. 2015/0216733, published August 6, 2015, titled "WOUND DRESSING AND METHOD OF TREATMENT," US Patent Application No. 14/418908, filed January 30, 2015, published as U.S. Publication No. 2015/0190286, published July 9, 2015, titled "WOUND DRESSING AND METHOD OF TREATMENT," US Patent Application No. 14/658,068, filed March 13, 2015, U.S. Application No. 2015/0182677, published July 2, 2015, titled "WOUND DRESSING AND METHOD OF TREATMENT," the disclosures of which are hereby incorporated by reference in their entireties. Embodiments of the wound dressings, wound treatment apparatuses and methods described herein may also be used in combination or in addition to those described in U.S. Patent Application No. 13/092,042, filed April 21 2011, published as US2011/0282309, titled "WOUND DRESSING AND METHOD OF USE," and which is hereby incorporated by reference in its entirety, including further details relating to embodiments of wound dressings, the wound dressing components and principles, and the materials used for the wound dressings.

[0047] Embodiments of the wound dressings, wound treatment apparatuses and methods described herein relating to wound dressings with electronics incorporated into the dressing may also be used in combination or in addition to those described in International Application No. PCT/EP2017/055225, filed March 6, 2017, titled "WOUND TREATMENT

APPARATUSES AND METHODS WITH NEGATIVE PRESSURE SOURCE INTEGRATED INTO WOUND DRESSING," and which is hereby incorporated by reference in its entirety herein, including further details relating to embodiments of wound dressings, the wound dressing components and principles, and the materials used for the wound dressings.

[0048] In some embodiments, a source of negative pressure (such as a pump) and some or all other components of the TNP system, such as power source(s), sensor(s), connector(s), user interface component(s) (such as button(s), switch(es), speaker(s), screen(s), etc.) and the like, can be integral with the wound dressing. The wound dressing can include various material layers described here and described in further detail in International Application No. PCT/EP2017/055225. The material layers can include a wound contact layer, one or more absorbent layers, one or more spacer layers, and a backing layer or cover layer covering the one or more absorbent and spacer layers. The wound dressing can be placed over a wound and sealed to the wound with the pump and/or other electronic components contained under the cover layer within the wound dressing. In some embodiments, the dressing can be provided as a single article with all wound dressing elements (including the pump) pre-attached and integrated into a single unit. In some embodiments, a periphery of the wound contact layer can be attached to the periphery of the cover layer enclosing all wound dressing elements as illustrated in Figure 1A-1B. Details of the various components of the wound dressing are described in more detail in International Application No. PCT/EP2017/055225. Specifically, Figures 13 and 14 of International Application No. PCT/EP2017/055225 describe the dressing layers and components associated with an offset pump adjacent to an absorbent area. Such embodiments and description provide details for the materials and alternative embodiment described herein with reference to Figures 1A and 1B.

[0049] In some embodiments, the pump and/or other electronic components can be configured to be positioned adjacent to or next to the absorbent and/or transmission layers so that the pump and/or other electronic components are still part of a single apparatus to be applied to a patient. However, in some embodiments, the pump and/or other electronics are positioned away from the wound site. Figure 13 of International Application No. PCT/EP2017/055225 illustrates a wound dressing with the pump and/or other electronics positioned away from the wound site. The wound dressing can include an electronics area 1361 and an absorbent area 1360. The absorbent area 1360 can include an absorbent material 1312 and can be positioned over the wound site. The electronics area 1361 can be positioned away

from the wound site, such as by being located off to the side from the absorbent area 1360. The electronics area 1361 can be positioned adjacent to and in fluid communication with the absorbent area 1360. The dressing can comprise a wound contact layer (not shown), a spacer layer (not shown), an absorbent layer 1312, a moisture vapor permeable film or cover layer 1313 positioned above the contact layer, spacer layer, absorbent layer, or other layers of the dressing. The wound dressing layers of the electronics area and the absorbent layer can be covered by one continuous cover layer 1313.

[0050] Figure 14 of International Application No. PCT/EP2017/055225 illustrates an embodiment of a wound dressing with the pump and electronic components offset from the absorbent area of the dressing positioned over the wound. The wound dressing can comprise a wound contact layer 1310 and a moisture vapor permeable film or cover layer 1313 that enclose an absorbent area 1360 and an electronics area 1361. The cover layer 1313 can seal to the wound contact layer 1310 at a perimeter. The dressing can comprise an upper spacer layer or first spacer layer 1317 above the layers of the absorbent area. The spacer material or upper spacer layer 1317 can enable an air pathway between the two areas of the dressing.

[0051] As described with reference to Figure 14 of International Application No. PCT/EP2017/055225, the absorbent area 1360 of the dressing can comprise a second spacer layer 1311 or lower spacer layer and an absorbent layer 1322 positioned above the wound contact layer 1310. The second spacer layer 1311 can allow for an open air path over the wound site. The absorbent layer 1322 can comprise a super absorber positioned in the absorbent area 1360 of the dressing. The absorbent layer 1322 can retain wound fluid within thereby preventing fluid passage of wound exudates into the electronics area 1361 of the dressing. The wound fluids can flow through the wound contact layer 1310, to the lower spacer layer 1311, and into the absorbent layer 1322. The wound fluids are then spread throughout the absorbent layer 1322 and retained in the absorbent layer 1322 as shown by the directional arrows for wound fluids in Figure 14 of International Application No. PCT/EP2017/055225.

[0052] As described with reference to Figure 14 of International Application No. PCT/EP2017/055225, in some embodiments, the electronics area 1361 of the dressing can comprise a plurality of layers of spacer material 1351 and electronic components 1350 embedded within the plurality of layers of spacer material 1351. The layers of spacer material can have recesses or cut outs to embed the electronic components within whilst providing structure to prevent collapse. The electronic components 1350 can include a pump, power

source, controller, and/or an electronics package. A partition 1362 can be positioned between the absorbent area 1360 and the electronics area 1361. The partition 1362 can separate the absorbent layer 1322 and lower air flow spacer layer 1311 from the electronic housing segment of the dressing in the electronic area. The partition 1362 can prevent wound fluid from entering the electronic housing section of the dressing. In some embodiments, the partition can be a non-porous dam or other structure. The non-porous dam 1362 can comprise a cyanoacrylate adhesive bead or a strip of silicone. The air pathway through the dressing is shown in Figure 14 of International Application No. PCT/EP2017/055225 by directional arrows. The air flows through the wound contact layer 1310, the lower spacer layer 1311, and the absorbent layer 1322 and into the first spacer layer 1317. The air can travel horizontally through the first spacer layer 1317 over and around the partition 1362 into the electronics area of the dressing.

[0053] A pump exhaust 1370 can be provided to exhaust air from the pump to the outside of the dressing. The pump exhaust can be in communication with the electronics area 1361 and the outside of the dressing. In some embodiments, the pump exhaust 1370 can be a flexible fluidic connector that comprises a 3D material that allows for pressure to be applied without collapse of the exhaust port. Examples of an application where additional disclosure relating to the 3D material can be found include US Publication No. 2015/0141941, titled "Apparatuses and Methods for Negative Pressure Wound Therapy" published on May 21, 2015. The disclosure of this patent application is hereby incorporated by reference in its entirety.

[0054] As used herein the upper layer, top layer, or layer above refers to a layer furthest from the surface of the skin or wound while the dressing is in use and positioned over the wound. Accordingly, the lower surface, lower layer, bottom layer, or layer below refers to the layer that is closest to the surface of the skin or wound while the dressing is in use and positioned over the wound. Additionally, the layers can have a proximal wound-facing face referring to a side or face of the layer closest to the skin or wound and a distal face referring to a side or face of the layer furthest from the skin or wound.

[0055] Figures 1A-1B illustrates a wound dressing apparatus incorporating the pump and/or other electronic components within the wound dressing and offset from the absorbent layer. Figures 1A-1B illustrates an embodiment of the absorbent area 60 and electronics area 61 of a wound dressing with integrated pump and/or electronics. The absorbent area can be similar to the absorbent area described with reference to Figures 13 and 14 of

International Application No. PCT/EP2017/055225. In some embodiments, as shown in Figure 1B, the absorbent area 60 comprises a spacer layer 52 positioned above the wound contact layer 51. An absorbent layer 50 can be provided above the spacer layer 52. In some embodiments, the electronics area 61 can include an electronics unit (not shown) and the electronics unit can be surrounded by a casing 73 (shown in Figures 2B-2C) forming an electronics cassette 62 or electronics cradle as described herein. In some embodiments, as described in more detail herein, the electronics unit can be provided in the electronics area without a casing. In some embodiments, the electronics cassette 62 and/or electronics unit is provided directly over the wound contact layer. In other embodiments, the electronics cassette 62 and/or electronics unit can be placed above a layer of wicking material, absorbent material, or spacer material that sits above the wound contact layer 51 of the dressing. For example, as shown in Figure 1B, the cassette 62 and/or electronics unit may be positioned over the spacer layer 52. In some embodiments, the spacer layer 52 can be a single layer of material extending below the electronics cassette 62 and/or electronics unit and the absorbent material 50. Thus, in some embodiments, the spacer layer 52 extends continuously through the absorbent area 60 and the electronics area 61. In alternative embodiments, the spacer layer below the electronics cassette 62 and/or electronics unit can be a different spacer layer than the spacer layer below the absorbent material 50. The spacer layer 52, absorbent material 50, and electronics cassette and/or electronics unit can be covered with a cover layer 63 that seals to a perimeter of the wound contact layer 51 as shown in Figures 1A-1B.

[0056] The electronics area 61 can include an electronics cassette 62 and/or electronics unit positioned below the cover layer 63 of the dressing. In some embodiments, the electronics unit can be surrounded by a material to enclose or encapsulate a negative pressure source and electronics components by surrounding the electronics. In some embodiments, this material can be a casing. In some embodiments, the electronics unit can be encapsulated or surrounded by a protective coating, for example, a hydrophobic coating as described herein. The electronics unit can be in contact with the dressing layers in the absorbent area 60 and covered by the cover layer 63. As used herein, the electronics unit or cassette 62 includes a lower or wound facing surface that is closest to the wound (not shown in Figure 1A) and an opposite, upper surface, furthest from the wound when the wound dressing is placed over a wound.

[0057] Figure 1B illustrates a cross sectional view of the wound dressing embodiments with an off-set integrated pump and electronics. In some embodiments, the wound dressing includes a wound contact layer 51 and a spacer layer 52. Above the spacer layer 52, the wound dressing includes an electronics cassette 62 or electronics unit 62 within the electronics area 61 adjacent to or next to the absorbent material 50 within the absorbent area 60. A top film or cover layer 63 can be applied or laminated over the top surface of the electronics cassette 62 or electronics unit 62 and the absorbent layer 50. The cover layer 63 can be sealed to the wound contact layer 51 at a perimeter of the dressing.

Electronics unit

[0058] Figures 2, 3A-3D, and 4A-4B illustrate embodiments of an electronics unit 67 that can be incorporated into a wound dressing. The electronics unit 67 of Figures 2, 3A-3D, and 4A-4B illustrate multiple views of embodiments of the electronics unit 67 without an electronics casing or other dressing material. Figures 2, 3B, and 4A illustrate a top view of embodiments of the electronics unit 67. Figures 4A and 5B illustrates a bottom or wound facing surface of the electronics unit 67.

[0059] Figures 2, 3A-3D, and 4A-4B illustrates an embodiment of an electronics unit 67 including a pump 72 and one or more batteries 68 or other power source to power the pump 72 and other electronics. The pump can operate at about 27 volts or about 30 volts. The two batteries can allow for a more efficient voltage increase (6 volts to 30 volts) than would be possible with a single battery.

[0060] The batteries 68 can be in electrical communication with a flexible circuit board 69. In some embodiments, one or more battery connections are connected to the top surface of the flexible circuit board 69. In some embodiments, the flexible circuit board can have other electronics incorporated within. For example, the flexible circuit board may have various sensors including, but not limited to, one or more pressure sensors, temperature sensors, optic sensors and/or cameras, and/or saturation indicators. The flexible circuit board 69 illustrated in Figure 2 communicates with a power switch 65 and the pump 72 and is folded or stepped down around the sides of a pump inlet protection (not shown) to contact the bottom surface of the battery contacts with the top surface of the flexible circuit board 69. In some embodiments, the flexible circuit board can have other electronics incorporated within. For example, the flexible circuit board may have various sensors including, but not limited to, one

or more pressure sensors, temperature sensors, optic sensors and/or cameras, and/or saturation indicators.

[0061] As illustrated in Figures 2, 3A-3D, and 4A-4B, the electronics unit 67 can include single button 65 on the upper surface of the unit. The single button 65 can be used as an on/off button or switch to stop and start operation of the pump and/or electronic components. In some embodiments, the switch 65 can be positioned on a top surface of the flexible circuit board 64. The switch 65 can be a dome type switch configured to sit on the top of the pump 72. Because the switch is situated within the dressing the cover layer can be easily sealed around or over the wound. In some embodiments, the cover layer can have an opening or hole positioned above the switch. The cover layer can be sealed to the outer perimeter of the switch 65 to maintain negative pressure under the wound cover. The switch can be placed on any surface of the electronics unit and can be in electrical connection with the pump.

[0062] In some embodiments, the upper surface of the electronics unit 67 can include one or more indicators 66 for indicating a condition of the pump and/or level of pressure within the dressing. In some embodiments, the indicators can be provided on the flexible circuit board 69. The indicators can be small LED lights or other light source that are visible through the dressing material or through holes in the dressing material above the indicators. The indicators can be green, yellow, red, orange, or any other color. For example, there can be two lights, one green light and one orange light. The green light can indicate the device is working properly and the orange light can indicate that there is some issue with the pump (e.g. dressing leak, saturation level of the dressing, and/or low battery).

[0063] The electronics unit 67 can also include one or more vents or exhausts 64 in communication with the pump outlet. The vent or exhaust 64 can be positioned on a pump outlet or exhaust mechanism 74. The pump outlet or exhaust mechanism 74 can be positioned at the outlet of the pump and extending to the upper surface of the electronics unit. As shown in Figures 2, 3A-3D, and 4A-4B, the pump outlet exhaust mechanism 74 is attached to the outlet of the pump and provides communication with the top surface of the dressing. In some embodiments, the exhaust mechanism 74 can be attached to the back surface of the pump and can extend out of the pump at a 90-degree angle from the pump orientation to communicate with the top surface of the dressing. The exhaust mechanism 74 can include an antibacterial membrane and/or a non-return valve. The exhausted air from the pump can pass through the pump outlet and exhaust mechanism 74. In some embodiments, the cover layer 63 (shown in

Figure 1A-1B) can include apertures or holes positioned above the exhaust vents 64 and/or membrane. The cover layer 63 can be sealed to the outer perimeter of the exhaust 64 to maintain negative pressure under the wound cover 63. In some embodiments, the exhausted air can be exhausted through the gas permeable material or moisture vapor permeable material of the cover layer. In some embodiments, the cover layer does not need to contain apertures or holes over the exhaust and the exhausted air is expelled through the cover layer. In some embodiments, the pump outlet mechanism 74 can be a custom part formed to fit around the pump as shown in Figure 2.

[0064] The electronic unit 67 can include a pump inlet protection mechanism (shown in Figures 3A-4B as 90 and 95) positioned on the portion of the electronics unit closest to the absorbent area and aligned with the inlet of the pump. The pump inlet protection mechanism can be positioned between the pump inlet and the absorbent area or absorbent layer of the dressing. The pump inlet protection mechanism can be formed of a hydrophobic material to prevent fluid from entering the pump.

[0065] The electronic unit 67 can include a pump inlet protection mechanism 90 or 95 shown in Figures 3A-3D and 4A-4B positioned on the portion of the electronics unit closest to the absorbent area and aligned with the inlet of the pump. The pump inlet protection mechanism 90 or 95 is positioned between the pump inlet and the absorbent area or absorbent layer of the dressing. The pump inlet protection mechanism 90 or 95 can be formed of a hydrophobic material to prevent fluid from entering the pump. In some embodiments, the pump inlet protection mechanism can be positioned on the pump inlet. In some embodiments, the pump inlet protection mechanism can be formed to fit around or over the pump inlet. The pump inlet protection mechanism 90 or 95 as shown in Figures 3A-3D and 4A-4B can be dome shaped, rectangular, curved, or can be any other shape to provide support to the flexible circuit board 69 and protect the pump inlet from fluid within the dressing. The pump inlet protection mechanism 90 or 95 can be a preformed sintered piece of material custom designed to fit the pump outlet and/or shape the flexible circuit board. In some embodiments, the pump 72, pump inlet protection mechanism 90 or 95, and pump outlet or exhaust mechanism 74 can be combined to formed a pump assembly as used herein.

[0066] In some embodiments, the components of the electronics unit 67 may include a protective coating to protect the electronics from the fluid within the dressing. The coating can provide a means of fluid separation between the electronics unit 67 and the

absorbent materials of the dressing. The coating can be a hydrophobic coating including, but not limited to, a silicone coating or polyurethane coating. The pump inlet component (90 and 95 shown in Figures 3A-3D and 4A-4B) can be used to protect the pump from fluid on the inlet and the pump outlet mechanism 74 can include a non-return valve that protects fluid from entering the outlet as described herein.

[0067] The electronics unit 67 includes one or more slits, grooves or recesses 71 in the unit between the pump and the two batteries. The slits, grooves or recesses 71 can allow for the electronics unit 67 to be flexible and conform to the shape of the wound. The unit 67 can have two parallel slits, grooves or recesses 71 forming three segments of the electronics unit 67. The slits, grooves or recesses 71 of the unit 67 create hinge points or gaps that allows for flexibility of the electronics unit at that hinge point. The pump exhaust 64, switch 65, and indicators 66 are shown on the top surface surrounded by the electronics unit 67. As illustrated, one embodiment of the electronics unit 67 has two hinge points to separate the unit into three regions or panels, for example one to contain one battery, one to contain the pump and one to contain another battery. In some embodiments, the slits, grooves or recesses may extend parallel with a longitudinal axis of the dressing.

Electronics Cassette

[0068] Figures 5A-5E illustrate embodiments of components of the electronics cassette 62. Figures 5A-5B illustrates an embodiment of an electronic cassette 62 with a rounded pump inlet 70. Figure 5A illustrates a bottom view of an embodiment of the electronics cassette 62 showing the wound facing side of the electronics cassette 62. Figure 5B illustrates a top view of an embodiment of the electronics cassette 62 showing the upper surface of the cassette.

[0069] Figures 5A-5B illustrate the electronics cassette 62 including a casing 73 as shown in Figures 5A-5B surrounding the electronics unit 67 described with reference to Figure 2. In some embodiments, the casing 73 can be used to support and encapsulate the electronics unit 67. In some embodiments, the casing can be made from a plastic material. In some embodiments, the casing 73 may be formed of a foam, an absorbent material, and/or a wicking material and may be in fluid communication with the absorbent area of the dressing. The encapsulation with a foam, an absorbent material, and/or a wicking material can protect against the pooling of the liquid around the electronics area. The casing 73 can be covered on the top

surface by a top film or cover layer when incorporated into a dressing. The top film or cover layer can cover the top surface of casing 73 as well as the layers of the absorbent area. The cover layer can have a hole for the exhaust and/or the switch area as described herein. The encapsulation of the electronics unit 67 with the casing 73 can provide support for the flexible printed circuit board (PCB) 69 and other components of the electronics unit 67. The casing 73 can provide support to the electronics unit 67, remain comfortable for the patient, and offer a means of continuous surface and height profile for the electronics unit.

[0070] Figure 5C illustrates an embodiment of a pump and electronics unit 87 without showing an electronics casing 83 surrounding the electronics unit thereby exposing the electronics unit 67 with the various electronics. Figures 5D-5E illustrated the electronics unit 87 enclosed in an electronic casing 83 forming the electronic cassette 87.

[0071] Figure 5C illustrates an embodiment of an electronics unit 87 with a rectangular pump inlet protection mechanism 80. Figures 5D-5E illustrate an embodiment of an electronic cassette 82 with a casing 83 enclosing the electronic unit 87 shown in Figure 5C. Figure 5D illustrates the bottom surface or wound facing surface of the electronics cassette 82. Figure 5E illustrates the top surface of the electronics cassette 82.

[0072] As illustrated in Figures 5B-5C and 5E, the electronics cassette 62 or 82 can allow the button 65 to be visible on the upper or top surface of the cassette. In some embodiments, the electronics casing 73 or 83 can have a hole aligned over the button 65 of the electronics unit. In other embodiments, the electronics casing 73 or 83 can be positioned over at least a portion of the switch 65 of the electronics unit but can still allow for the switch to be depressed and/or activated through the material. The switch or button 65 can be placed on any surface of the electronics cassette as long as it is in an electrical connection with the pump. In some embodiments, the switch or button 65 can be placed over the battery. In some embodiments, the battery profile is not as high as the pump and can provide room to place the switch over the battery.

[0073] The one or more vents 64 are shown on the top surface of the electronics cassette 62 or 82 as illustrated in Figures 5B-5C and 5E. In some embodiments, the electronics casing 73 or 83 can have holes where the vents 64 of the electronics unit align with. In other embodiments, the electronics casing 73 or 83 can have a gas permeable material positioned over at least a portion of the vents 64 of the electronics unit.

[0074] In some embodiments, the one or more indicators 66 can be visible on the upper surface of the electronics cassette 62 or 82 for indicating a condition of the pump and/or level of pressure within the dressing. In some embodiments, the electronics casing 73 or 83 can have holes that align with the indicators 66 of the electronics unit. In other embodiments, the electronics casing 73 or 83 can have a transparent material positioned over at least a portion of the indicators 66 of the electronics unit.

[0075] The batteries 68 can be in electrical communication with a flexible circuit board 69. In some embodiments, the flexible circuit board can have other electronics incorporated within. For example, the flexible circuit board may have various sensors including, but not limited to, one or more pressure sensors, temperature sensors, optic sensors and/or cameras, and/or saturation indicators.

[0076] In such embodiments, the components of the electronics unit 67 or 87 may include a protective coating as described herein to protect the electronics from the fluid within the dressing. The coating can be provided between the electronics and the casing 73 and 83.

[0077] The electronic cassette 62 or 82 can have an opening or aperture for the pump inlet protection mechanism 70 or 80 positioned on the inlet of the pump 72 of the electronics unit 67 or 87 and the portion of the electronics cassette closest to the absorbent area. The pump inlet protection mechanism 70, 80, 90, or 95 as shown in Figures 2, 3A-3D, 4A-4B, and 5A-5E can be dome shaped, rectangular, curved, or can be any other shape to provide support to the flexible circuit board 69, 89 and protect the pump inlet from fluid within the dressing. The pump inlet protection mechanism can be a preformed sintered piece of material custom designed to fit the pump outlet and/or shape the flexible circuit board.

[0078] As illustrated in Figure 5A and 5D, the electronics cassette 62 includes one or more slits, grooves or recesses 81 in the casing 73 or 83. The slits, grooves or recesses 81 can allow for the electronics cassette 62 to be flexible and conform to the shape of the wound. The slits, grooves or recesses 81 of the electronics cassette can align with the slits, grooves or recesses 71 of the electronics unit 67 or 87. The casing can have two parallel slits, grooves or recesses 81 forming three segments in the electronics cassette 62. The slits, grooves or recesses 81 of the casing 73 create hinge points or gaps that allows for flexibility of the casing at that hinge point.

[0079] Figure 5B and 5E illustrates embodiments of a top view of the electronics cassette 62 or 82. The pump exhaust 64, switch 65, and indicators 66 are shown on the top

surface surrounded by the casing 73 or 83. As illustrated, one embodiment of the electronics cassette 62 or 82 has two hinge points, slits, grooves or recesses 81 on the top or upper surface of the cassette to separate the cassette into three regions or panels, for example one to contain one battery, one to contain the pump and one to contain another battery. In some embodiments, the hinge points, slits, grooves or recesses can be on the top surface, bottom surface, or on both the top and bottom surfaces of the cassette. In some embodiments, the slits, grooves or recesses may extend parallel with a longitudinal axis of the dressing.

[0080] The electronics unit 87 and electronics cassettes for Figures 5C-5E are similar to the electronics unit and cassette described with reference to Figure 5A-5B. However, the electronics unit 67 and pump inlet protection mechanism 70 of Figure 5A-5B is similar to the electronics unit 67 and pump inlet protection mechanism 70 described with reference to Figure 2. Figures 5D-5E illustrate an embodiment of the electronic cassette 82 with the electronics unit 87 and pump inlet protection mechanism 80 of Figure 5C. Figure 5C illustrates an embodiment of a pump and electronics unit 87 without showing the electronics casing 73 surrounding the electronics unit. The flexible circuit board 89 and pump inlet protection 80 have a different configuration than the electronic unit 67 shown in Figure 2. In some embodiments, the portions of the flexible circuit board 89 that attaches to the batteries 68 is folded under the portion of the flexible circuit that contains the on/off switch 65. Since the flexible circuit board is folded under itself, the surface of the flexible circuit board that connects the batteries contacts can be facing the wound surface as shown in Figure 5C. Due to this configuration, the battery contacts are not visible from the top view of the electronics unit as shown in Figure 5C. Figures 5C-5E illustrate the pump inlet protection device 80 that fits to the opening in the electronics cassette.

[0081] Figures 6A-6D illustrate an embodiment of the flexible circuit board for use in the electronics cassette. The flexible circuit board illustrated in Figures 6A-6D is similar to the flexible circuit board 69 described with reference to Figure 2. The flexible circuit board includes a fold 140 to allow the flexible circuit board to be positioned under battery contacts when integrated into the electronics unit as illustrated in Figure 2. Figure 6E illustrates the area (hatched) that could be bonded to for sealing between the top film or electronics casing and the flexible printed circuit board.

[0082] Figures 7A-7D illustrate embodiments of electronic cassettes with two pump exhaust vents 64 in various configurations and shapes. In some embodiments, the two

pump exhaust vents 64 can be various shapes. The two pump exhaust vents 64 can be circular as shown in Figure 7A, irregular shaped as shown in Figure 7B, triangular as shown in Figure 7C, crescent shaped as shown in Figure 7D, or any other shape including but not limited to a rectangle, square, rounded rectangle, rounded square, oval, or racetrack oval shaped. The two pump exhausts allow for one exhaust to become blocked, occluded, or inoperable while still allowing the other exhaust to function.

[0083] Figures 8A-8C illustrates embodiments of electronic cassettes with one pump exhaust vent 64 in various shapes. The pump exhaust vents 64 can be irregular shaped as shown in Figure 8A, crescent shaped as shown in Figure 8B, racetrack oval shaped as shown in Figure 8C, or any other shape including, but not limited to, a circle, rectangle, square, rounded rectangle, rounded square, oval, or triangle shaped.

[0084] Figures 9A-9D illustrate various embodiments of the electronic cassette with various configurations for components on the electronic cassettes. In some embodiments, one or more pump exhaust vents 64 can be used as described with reference to Figures 7A-7D and 8A-8C. Figures 9A-9B illustrates two exhaust vents 64. Figures 9C and 9D illustrate an electronics cassette with one exhaust vent 64. In some embodiments, the on/off switch or button 65 and one or more indicators 66 can be positioned on different portions of the electronic cassette. In some embodiments, the on/off switch or button 65 and one or more indicators 66 can be positioned on the right panel of the electronic cassette as shown in Figure 9A and 9C. In some embodiments, the on/off switch or button 65 and one or more indicators 66 can be positioned on the left panel of the electronic cassette as shown in Figure 9B and 9D.

[0085] Figure 10 illustrates an embodiment of the electronics cassette similar to the electronics cassette described with reference to Figure 5A-5B and 5D-5E. The electronics cassette is shown with two openings in the casing for the indicators 66 on the top surface of the cassette. The electronics cassette as illustrated in Figure 10 includes a casing that completely covers the battery portion underlying the casing.

[0086] In some embodiments, one or more of the exhaust vents 64, switch or button 65, and one or more indicators 66 described with reference to Figures 7A-7D, 8A-8C, 9A-9D, and 10 can be the exhaust vents 64, switch or button 65, and/or one or more indicators 66 of the electronics unit described with reference to Figures 2, 3A-3D, and 4A-4B visible through holes or apertures in the casing of the electronics cassette. In some embodiments, one or more of the exhaust vents 64, switch or button 65, and/or one or more indicators 66 described with

reference to Figures 7A-7D, 8A-8C, 9A-9D, and 10 can include material of the casing of the electronics cassette that covers the exhaust vents 64, switch or button 65, and one or more indicators 66 of the electronics unit described with reference to Figures 2, 3A-3D, and 4A-4B. In some embodiments, a gas permeable material can be provided as part of the casing of the electronics cassette that covers at least a portion of the exhaust vents 64 described with reference to Figures 7A-7D, 8A-8C, 9A-9D. In some embodiments, a transparent material can be provided as part of the casing of the electronics cassette that covers at least a portion of the one or more indicators 66 described with reference to Figures 7A-7D, 8A-8C, 9A-9D. In some embodiments, the material of the casing of the cassette covering at least a portion of the switch or button 65 described with reference to Figures 7A-7D, 8A-8C, 9A-9D can be flexible or otherwise allow for the switch or button 65 to be depressed or activated.

[0087] Figures 11-16 illustrate an assembly process for the electronics unit of the electronics cassette. Figure 11 illustrates an embodiment of a flexible printed circuit 269. The flexible printed circuit board 269 can have all components on one side as shown in Figure 11. In other embodiments, the flexible printed circuit board 269 can have some components on each side of the flexible printed circuit board 269. Figure 12 illustrates the use of a polyimide tape or other material 240 that can be applied to the underside of the flexible circuit board 269 covering the components of the flexible circuit board 269. The polyimide tape or other insulating or encapsulating material can serve the purpose of encapsulation, electrical isolation, and mechanical strain relief for the batteries. In some embodiments, the electronics can be facing down to help with Electrostatic Discharge (ESD) and/or Electromagnetic Compatibility (EMC) of the device when worn.

[0088] In some embodiments, the electronics unit or assembly can be fit into a jig. The flexible circuit 269 can be fit in a jig. The batteries 268 can be fit into a jig as shown with reference to Figure 13. In some embodiments, the batteries can include battery contacts 230 that can be spot welded to the flexible circuit board 269. A top layer of polyimide tape or other insulating or encapsulating material 241 can be applied over the assembled battery contacts as shown in Figure 14. This material can serve the purpose of encapsulation, electrical isolation, and mechanical strain relief for the batteries.

[0089] In some embodiments, a pump 272 can be pre-assembled with the custom inlet mechanism 270 and outlet mechanism 274 to form a pump assembly. As illustrated in Figure 15, the pump assembly can be jiggled into position. The pump 272 can have solder

connections, so the pump assembly can be soldered onto the flexible printed circuit. The pump 272 can be encapsulated with a sealant that can be applied over these solder joints.

[0090] In some embodiments, the switch area 265 can be positioned on the top side of the flexible PCB 269 and over the top surface of the pump as shown in Figure 16. In some embodiments, the portion of the PCB with the switch area 265 can be folded over onto the pump or pump assembly. In some embodiments, a spacer material can be placed over the assembly to fill the gaps between the components of the electronics and casing of the cassette.

[0091] Figure 17 illustrates an embodiment of on/off switch that can be used with a wound dressing with integrated electronics and with electronic units and cassettes described herein.

[0092] The dressings described herein incorporate electronic components in a portion of the dressing offset from the portion of the dressing placed over the wound. Components can be incorporated into the dressing to provide a barrier that stops liquid from entering into the area near the electronics or encapsulates the electronics to protect the electronic components from fluid within the dressing. In some embodiments, the electronics can be encapsulated in a hydrophobic coating to protect the electronics from fluid within the dressing. A casing can be wrapped around the encapsulated electronics unit forming the electronics cassette. The casing can be a soft or patient compatible material to minimize the discomfort of a patient when the wound dressing with integrated electronics are in contact with the wound or skin. In some embodiments, the casing can include an absorbent or wicking material that allows the flow of fluid through the casing.

Electronics Cradle

[0093] Figure 18 illustrates an embodiment of a wound dressing incorporating an electronics unit 67 within the dressing. In some embodiments, the wound dressing can include a wound contact layer 104. The dressing can also include a spacer layer 105 which may be made of a 3D material above the wound contact layer. In some embodiments, the electronics sub assembly or electronics unit 67 can be embedded in an absorbent pad 102 towards one end of the dressing, as depicted in Figure 18. Figure 18 illustrates dressing layers with an electronics area A and an absorbent area B. In some embodiments, the electronics area A can include the electronics unit 67. In some embodiments, the absorbent area B can include the absorbent material 102 and can be positioned over the wound area to absorb fluid from the

wound within the absorbent material or pad 102. The electronics unit 67 can be positioned in a hole in the absorbent pad 102 and can be surrounded by the absorbent pad as illustrated in Figure 18 with the absorbent pad 102 on each side of the electronics unit 67. However, the presence of the electronics unit, since it is entirely non-absorbent, could physically inhibit the migration of wound exudate through the absorbent pad from area A to area B, the main body of the pad, and would thus result in pooling of wound exudate in area A. This can be deleterious to the patient, resulting in maceration of the skin and other potentially harmful effects.

[0094] Therefore, it can be useful to devise a dressing to facilitate normal distribution of exudate by which the fluid can be distributed through the entire pad, preventing pooling.

[0095] In some embodiments, a construct can be used that acts like a support mechanism or cradle for the electronics sub assembly. Figure 19A illustrates an embodiment of the electronics unit 67. The electronics unit 67 can be coated and/or include a pump inlet and outlet protection mechanism to protect the pump from the fluid environment of the dressing as described herein. Figure 19B illustrates an embodiment of the material of the cradle 501 that can be within, adjacent to, and/or above the absorbent dressing material 502. In some embodiments, the cradle 501 is positioned adjacent to the dressing material 502 as illustrated in Figures 19B and 19C. Figure 19C illustrates an embodiment of the electronics unit 67 incorporated into the cradle 501 and adjacent to an absorbent pad 502. The shape and form of the cradle can be advantageous to production of an ergonomic form for the device. An embodiment of an electronics cradle incorporated within a wound dressing is shown in Figures 19B-19C. An embodiment of the electronics assembly to be used with the cradle 501 is shown in Figure 19A.

[0096] The cradle can be constructed from hydrophilic materials (e.g. PU foam, cellulosic fiber). In some embodiments, the cradle 501 can be in intimate contact with the absorbent pad 502 to facilitate fluid distribution, thus preventing pooling, as depicted in Figures 19B-19C. In some embodiments, the electronics cradle 501 can be in direct contact with the wound contact layer (not shown).

[0097] The cradle can include recesses, cutouts, or slots 503 and 504 within the cradle material 501 for receiving components of the electronics unit 67 as illustrated in Figure 19B. The electronics unit 67 can be fit into the recesses 503 and 504 of the cradle material 501. In some embodiments, the cradle can include one or more recess 503 shaped to receive

the batteries and a recess 504 shaped to receive the pump with the pump inlet and pump outlet mechanisms of the electronics unit as illustrated in Figure 19B. In some embodiments, once the electronics unit is fit within the cradle, the top of the electronics unit can be flush with or can have a similar height profile as the electronics cradle material. The cradle can be a soft or patient compatible material to minimize the discomfort of a patient when the wound dressing with integrated electronics are in contact with the wound or skin. In some embodiments, the cradle can include an absorbent or wicking material that allows the flow of fluid through the casing.

[0098] Figures 20A-20B illustrate an embodiment of a wound dressing 600 incorporating the electronics unit 667 and electronics cradle 601 adjacent to and at least partially overlapping the absorbent pad 602. In such embodiment, the cradle 601 material is formed to house the electronics unit 667 and a portion of the absorbent pad 602. In some embodiments, this configuration can provide intimate contact between absorbent pad 602 and the cradle 601. In some embodiments, the cradle 601 and absorbent pad 602 can be positioned over a transmission or spacer layer 605. As illustrated in Figures 20A-20B, the relative positions of the components can be varied as necessary. In some embodiments, the cradle 601 may be formed of the same material as the absorbent pad 602. In other embodiments, the cradle 601 may also be formed of a dissimilar material than the absorbent pad 602, e.g. absorbent polyurethane foam. In some embodiments, the cradle 601 may be formed using vacuum forming or thermoforming processes.

[0099] In some embodiments, the absorbent components and electronics components can be overlapping but offset. For example, a portion of the electronics area can overlap the absorbent area, for example overlapping the superabsorber layer, but the electronics area is not completely over the absorbent area. Therefore, a portion of the electronics area can be offset from the absorbent area and only provided over the cushioning transmission or spacer layers 605. The dressing layer and electronic components can be enclosed in a wound contact layer (not shown) positioned below the lower most layer and a cover layer (not shown) positioned above the absorbent layer and electronics. The wound contact layer and cover layer can be sealed at a perimeter enclosing the dressing components. In some embodiments, the cover layer can be in direct physical contact with the absorbent material, the cradle and/or electronics unit. In some embodiments, the cover layer can be sealed to a portion of the electronics unit and/or cassette, for example, in areas where holes or

apertures are used accommodate the electronic components (e.g. a switch and/or exhaust) as described herein with reference to the electronics cassette.

Dressing Assembly with Integrated Electronics

[0101] The dressing layers can be assembled with various material layers in several configurations. In some embodiments, the electronics unit can be assembled within the wound dressing adjacent to the absorbent layer as described above. Figures 21A-21F illustrate an embodiment of a wound dressing incorporating an electronics unit resting in a cradle. In alternative embodiments, the dressing layers described with reference to Figures 21A-21F can incorporate an electronics unit within an electronics cassette as described with reference to Figures 5A-5E, 7A-7D, 8A-8C, 9A-9D, and 10 herein. In such embodiments, the electronics cassette can be used instead of the electronics cradle described with reference to Figures 21A-21F.

[0101] Figure 21A illustrates an embodiment of a spacer layer 701. The spacer layer can be provided over a wound contact layer (not shown). The wound contact layer is placed in contact with the wound as described herein.

[0102] As illustrated in Figures 21A-21F, the wound dressing layers can include an absorbent area 760 and an electronics area 761. In some embodiments, the electronics area 761 can include the electronics unit 704. In some embodiments, the absorbent area 760 can include the absorbent material 702 and can be positioned over the wound area to absorb fluid from the wound within the absorbent material or pad 702. Figure 21B and 21C illustrates an embodiment of the spacer layer 701 with an absorbent layer 702 provided over the absorbent area 706 of the spacer layer 701. In Figures 21B-21C, the spacer layer 701 in the electronics area 761 is visible while the spacer layer 701 in the absorbent area 760 is obscured by the overlying absorbent layer 702.

[0103] Figure 21C illustrates an embodiment of an electronics unit 704 and a cradle 705 shown removed from the wound dressing layers. The cradle 705 include recesses, cutout, or slots 706 within the cradle. The recesses 706 are shaped to fit portions of the electronics unit. The recesses 706 can be shaped in a complementary shape that matches the shape of portions of the underside of the electronics unit 704 similar to the electronics unit 67 shown and described with reference to Figures 2, 3A-3D, and 4A-4B. For example, the recesses 706 can be the shape of the batteries and pump assembly as shown in Figures 21C-21E. Figures

21D-21F illustrate an embodiment of a wound dressing with the cradle 705 positioned over the spacer layer 701 of the electronics area 761. The cradle 705 can be positioned adjacent to the absorbent layer 702. Figure 21F illustrates an embodiment of the wound dressing with the electronics unit 704 within the recess 706 of the electronics cradle 705. The dressing layers and components shown in Figure 21F can be enclosed in a wound contact layer (not shown) positioned below the spacer layer 701 and a cover layer (not shown) positioned above the absorbent layer 702 and electronics 704 within the cradle 705. The wound contact layer and cover layer can be sealed at a perimeter enclosing the dressing components.

[0104] Figures 22A-22C illustrate another embodiment of a wound dressing incorporating an electronics unit 804 and cradle 805 in the wound dressing. In alternative embodiments, the dressing layers described with reference to Figures 22A-22C can incorporate an electronics unit within an electronics cassette as described with reference to Figures 5A-5E, 7A-7D, 8A-8C, 9A-9D, and 10 herein. In such embodiments, the electronics cassette can be used instead of the electronics cradle described with reference to Figures 22A-22C.

[0105] Figure 22A illustrates an embodiment of a wound dressing including a spacer layer 801, absorbent layer 802, and cradle 805. As illustrated in Figures 22A-22C, the wound dressing layers can include an absorbent area 860 and an electronics area 861. In some embodiments, the electronics area 861 can include the electronics unit 804. In some embodiments, the absorbent area 860 can include the absorbent material 802 and can be positioned over the wound area to absorb fluid from the wound within the absorbent material or pad 802.

[0106] The absorbent layer 802 as shown in Figures 22A-22C can be positioned above the spacer layer 801 in the absorbent area 860 and the electronics area 861 and spans the length of the dressing. The cradle 805 can be positioned above the absorbent layer 802 in the electronics area 861. Figure 22A illustrates the recesses 806 in the cradle 805 similar to the recesses described herein with reference to Figures 21A-21F. Figures 22B and 22C illustrate the electronics unit 804 positioned within the recesses 806 of the cradle. The dressing layers and components shown in Figures 22B and 22C can be enclosed in a wound contact layer (not shown) positioned below the spacer layer 801 and a cover layer (not shown) positioned above the absorbent layer 802 and electronics 804 within the cradle 805. The wound contact layer and cover layer can be sealed at a perimeter enclosing the dressing components.

[0107] Figure 23 illustrates an absorbent layer 902 provided over the entire length of the spacer layer 901. As illustrated in Figure 23, the wound dressing layers can include an absorbent area 960 and an electronics area 961. In some embodiments, the electronics area 961 can include the electronics unit. In some embodiments, the absorbent area 960 can include the absorbent material 902 and can be positioned over the wound area to absorb fluid from the wound within the absorbent material or pad 902. The absorbent layer has one recess, cutout, or slot 907 in the portion of the absorbent layer 902 located in the electronics area 961. The spacer layer 901 is visible in the recess 907 of the absorbent layer 902. In some embodiments, as shown in Figure 23 the absorbent material 902 spans the length of the dressing and can include a single aperture 907 in the absorbent material 902. In some embodiments, the electronics cradle or electronics cassette described herein can be positioned within the single aperture 907 in the absorbent material or absorbent layer 902 of the dressing. In such embodiments, an electronic unit can be positioned within the electronics cradle or electronics cassette as described herein. The dressing layers and components shown in Figure 23 can be enclosed in a wound contact layer (not shown) positioned below the spacer layer 901 and a cover layer (not shown) positioned above the absorbent layer 902 and electronics cradle or cassette. The wound contact layer and cover layer can be sealed at a perimeter enclosing the dressing components.

[0108] Figure 24 illustrates an embodiment of a wound dressing incorporating an electronics unit resting in a cradle 1005. In alternative embodiments, the dressing layers described with reference to Figure 24 can incorporate an electronics unit within an electronics cassette as described with reference to Figures 5A-5E, 7A-7D, 8A-8C, 9A-9D, and 10 herein. In such embodiments, the electronics cassette can be used instead of the electronics cradle described with reference to Figure 24. As illustrated in Figure 24, the wound dressing layers can include an absorbent area 1060 and an electronics area 1061. In some embodiments, the electronics area 1061 can include the electronics unit 1004 and electronics cradle 1005. In some embodiments, the absorbent area 1060 can include the absorbent material 1002 and can be positioned over the wound area to absorb fluid from the wound within the absorbent material or pad 1002. Figure 24 illustrates a spacer layer 1001 and an absorbent layer 1002 positioned adjacent to a cradle 1005 and electronics unit 1004. The dressing configuration illustrated in Figure 24 is similar to the dressing described with reference to Figures 21A-21F. However, the spacer layer 1001 as shown in Figure 24 does not extend the entire length of the dressing.

Instead, the spacer layer 1001 only extends to an edge of the cradle 1005 and the cradle is positioned to be in direct contact with an underlying wound contact layer 1006. As illustrated in Figure 24, the spacer layer 1001 and absorbent layer 1002 are positioned in the absorbent area 1060 and do not extend to the electronics area 1061. The cradle 1005 and electronics unit 1004 are positioned in the electronics area 1061. Figure 24 illustrates the layers of a wound dressing and electronics area shown with the wound contact layer 1006 and without the cover layer. The dressing layers and components shown in Figure 24 can be enclosed in a wound contact layer 1006 positioned below the spacer layer and cradle and a cover layer (not shown) positioned above the absorbent layer and electronics unit 1004 within the cradle 1005. The wound contact layer 1006 and cover layer can be sealed at a perimeter enclosing the dressing components.

[0109] Figures 25A-25B illustrate embodiments of an assembled wound dressing with the dressing layers enclosed between a wound contact layer (not shown) and a cover layer 1110. As illustrated in Figures 25A-25B, the wound dressing layers can include an absorbent area 1160 and an electronics area 1161. In some embodiments, the electronics area 1161 can include the electronics unit 1104 and electronics cradle 1105. In some embodiments, the absorbent area 1160 can include the absorbent material 1102 and can be positioned over the wound area to absorb fluid from the wound within the absorbent material or pad 1102. The wound dressing can include a spacer layer 1101 as illustrated in Figure 25A. The dressing layers and components shown in Figures 25A-25B can be enclosed in a wound contact layer (not shown) positioned below the spacer layer 1101 and a cover layer 1110 positioned above the absorbent layer 1102 and electronics unit 1104 within the cradle 1105. The wound contact layer and cover layer 1110 can be sealed at a perimeter enclosing the dressing components.

[0110] Figure 26 illustrates an embodiment of an assembled wound dressing similar to the dressing shown in Figures 25A-25B. However, the wound dressing of Figure 26 includes an additional masking or obscuring layer 1208 positioned above the dressing layers and below the cover layer 1210. As illustrated in Figure 26, the wound dressing layers can include an absorbent area 1260 and an electronics area 1261. In some embodiments, the electronics area 1261 can include the electronics unit 1204. In some embodiments, the absorbent area 1260 can include the absorbent material and can be positioned over the wound area to absorb fluid from the wound within the absorbent material or pad. In some embodiments, the masking or obscuring layer 1208 can be positioned above the absorbent layer

and electronics 1204 and below the cover layer 1210. In some embodiments, the masking or obscuring layer 1208 can include an aperture 1209 that allows the electronics 1204 below the masking or obscuring layer 1208 to be visible as shown in Figure 26. In some embodiments, the masking or obscuring layer 1208 can be an opaque material that does not allow the wound exudate or other fluid to be visible from a top view of the wound dressing. In some embodiments, the masking or obscuring layer can span the entire length of the absorbent area 1260 and electronics area 1261. In some embodiments, the masking or obscuring layer can have a larger perimeter than the spacer layer, absorbent layer, and electronics unit, cradle, or cassette and can overborder the absorbent material and electronics unit, cradle, or cassette as shown in Figure 26.

[0111] In some embodiments, the absorbent components and electronics components can be overlapping but offset. For example, a portion of the electronics area can overlap the absorbent area, for example overlapping the superabsorber layer, but the electronics area is not completely over the absorbent area. Therefore, a portion of the electronics area can be offset from the absorbent area and only provided over the cushioning spacer layers.

[0112] All of the features disclosed in this specification (including any accompanying exhibits, claims, abstract and drawings), and/or all of the steps of any method or process so disclosed, may be combined in any combination, except combinations where at least some of such features and/or steps are mutually exclusive. The disclosure is not restricted to the details of any foregoing embodiments. The disclosure extends to any novel one, or any novel combination, of the features disclosed in this specification (including any accompanying claims, abstract and drawings), or to any novel one, or any novel combination, of the steps of any method or process so disclosed.

[0113] Conditional language, such as “can,” “could,” “might,” or “may,” unless specifically stated otherwise, or otherwise understood within the context as used, is generally intended to convey that certain embodiments include, while other embodiments do not include, certain features, elements, or steps. Thus, such conditional language is not generally intended to imply that features, elements, or steps are in any way required for one or more embodiments or that one or more embodiments necessarily include logic for deciding, with or without user input or prompting, whether these features, elements, or steps are included or are to be performed in any particular embodiment. The terms “comprising,” “including,” “having,” and

the like are synonymous and are used inclusively, in an open-ended fashion, and do not exclude additional elements, features, acts, operations, and so forth. Also, the term “or” is used in its inclusive sense (and not in its exclusive sense) so that when used, for example, to connect a list of elements, the term “or” means one, some, or all of the elements in the list. Likewise the term “and/or” in reference to a list of two or more items, covers all of the following interpretations of the word: any one of the items in the list, all of the items in the list, and any combination of the items in the list. Further, the term “each,” as used herein, in addition to having its ordinary meaning, can mean any subset of a set of elements to which the term “each” is applied. Additionally, the words “herein,” “above,” “below,” and words of similar import, when used in this application, refer to this application as a whole and not to any particular portions of this application.

[0114] Conjunctive language such as the phrase “at least one of X, Y, and Z,” unless specifically stated otherwise, is otherwise understood with the context as used in general to convey that an item, term, etc. may be either X, Y, or Z. Thus, such conjunctive language is not generally intended to imply that certain embodiments require the presence of at least one of X, at least one of Y, and at least one of Z.

[0115] Language of degree used herein, such as the terms “approximately,” “about,” “generally,” and “substantially” as used herein represent a value, amount, or characteristic close to the stated value, amount, or characteristic that still performs a desired function or achieves a desired result. For example, the terms “approximately,” “about,” “generally,” and “substantially” may refer to an amount that is within less than 10% of, within less than 5% of, within less than 1% of, within less than 0.1% of, and within less than 0.01% of the stated amount. As another example, in certain embodiments, the terms “generally parallel” and “substantially parallel” refer to a value, amount, or characteristic that departs from exactly parallel by less than or equal to 15 degrees, 10 degrees, 5 degrees, 3 degrees, 1 degree, or 0.1 degree.

[0116] Various modifications to the implementations described in this disclosure may be readily apparent to those skilled in the art, and the generic principles defined herein may be applied to other implementations without departing from the spirit or scope of this disclosure. Thus, the disclosure is not intended to be limited to the implementations shown herein, but is to be accorded the widest scope consistent with the principles and features

disclosed herein. Certain embodiments of the disclosure are encompassed in the claim set listed below or presented in the future.

[0117] It is to be understood that, if any prior art publication is referred to herein, such reference does not constitute an admission that the publication forms a part of the common general knowledge in the art, in Australia or any other country.

[0118] In the claims which follow and in the preceding description of the invention, except where the context requires otherwise due to express language or necessary implication, the word “comprise” or variations such as “comprises” or “comprising” is used in an inclusive sense, i.e. to specify the presence of the stated features but not to preclude the presence or addition of further features in various embodiments of the invention.

WHAT IS CLAIMED IS:

1. A wound dressing apparatus comprising:
 - a wound contact layer configured to be positioned in contact with a wound;
 - a first area over the wound contact layer comprising:
 - a spacer layer; and
 - an absorbent layer over the spacer layer;
 - a second area over the wound contact layer comprising an electronics cassette, the electronics cassette comprising at least one of a negative pressure source and electronic components, surrounded by a casing, wherein the first area is positioned adjacent to the second area,
 - wherein the casing is configured to surround at least one of the negative pressure source and the electronic components and to allow fluid communication between the first area and second area; and
 - a cover layer configured to cover and form a seal over the wound contact layer, the first area, and the second area,
 - wherein the electronic components are encapsulated in a hydrophobic coating and wherein the wound dressing apparatus further comprises a negative pressure source inlet protection mechanism and a negative pressure source outlet.
2. The wound dressing apparatus of Claim 1, wherein the electronic components comprise one or more of: a power source; a flexible circuit board; a sensor; a switch; a light; and an LED indicator.
3. The wound dressing apparatus of Claim 1 or Claim 2, wherein the negative pressure source outlet is a negative pressure source exhaust.
4. The wound dressing apparatus of Claim 3, wherein at least one of the negative pressure source outlet and the negative pressure source exhaust comprise an antibacterial membrane.

5. The wound dressing apparatus of Claims 3 or Claim 4, wherein at least one of the negative pressure source outlet and the negative pressure source exhaust comprise a non-return valve.
6. The wound dressing apparatus of any one of Claims 3-5, wherein the cover layer comprises an aperture over the outlet or the exhaust.
7. The wound dressing apparatus of any one of the preceding Claims, wherein the negative pressure source inlet protection mechanism comprises a hydrophobic material configured to prevent fluid from entering the negative pressure source.
8. The wound dressing apparatus of any one of the preceding Claims, wherein the electronics cassette comprises one or more slits, grooves or recesses in the casing, wherein the slits, grooves or recesses are configured to provide one or more hinge points in the casing and increase flexibility of the electronics cassette.
9. The wound dressing apparatus of any one of the preceding Claims, wherein the spacer layer extends within both the first area and the second area and the electronics cassette is provided over the spacer layer.
10. The wound dressing apparatus of any one of the preceding Claims, wherein negative pressure source is encapsulated in a hydrophobic coating.

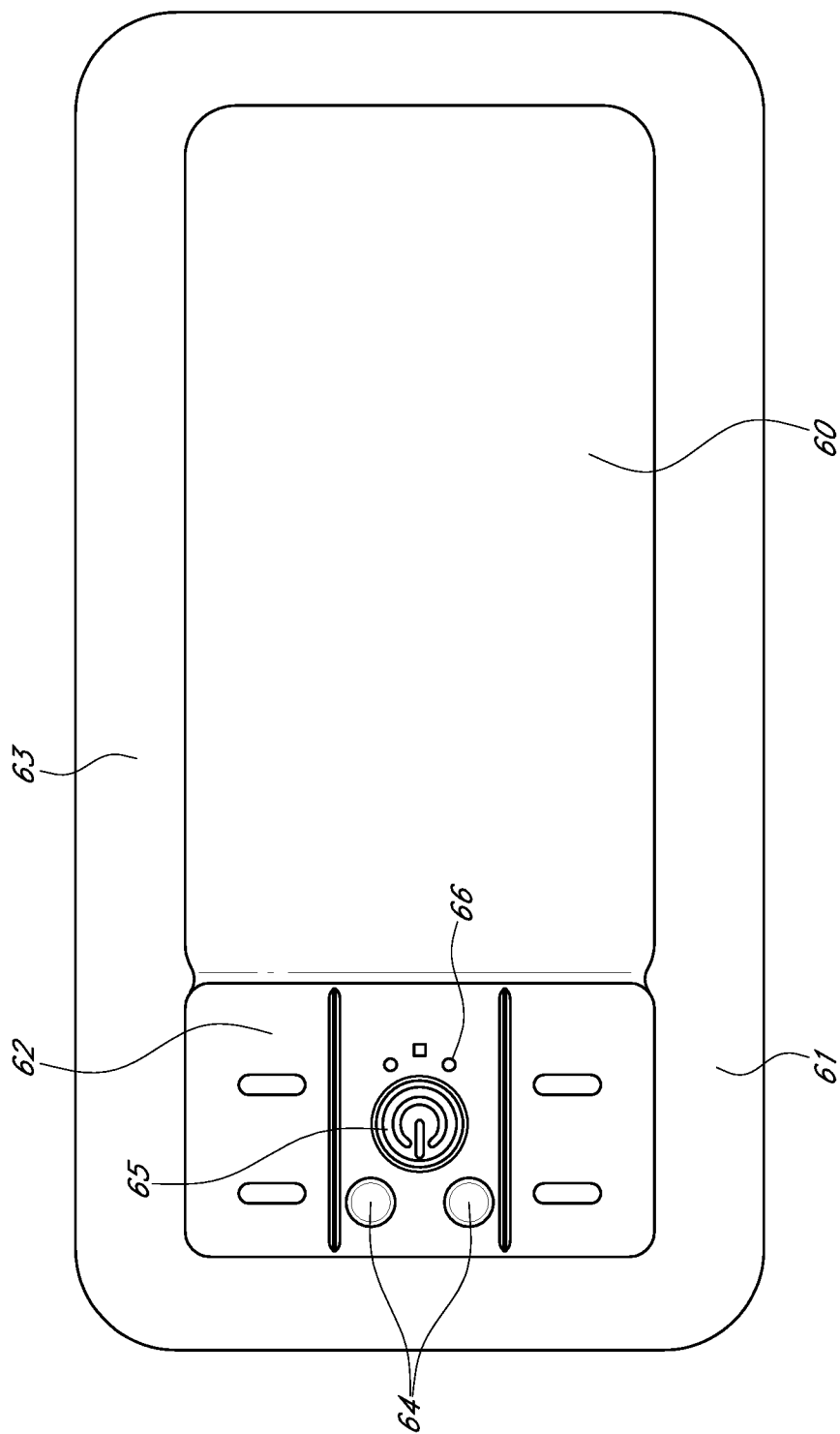

FIG. 1A

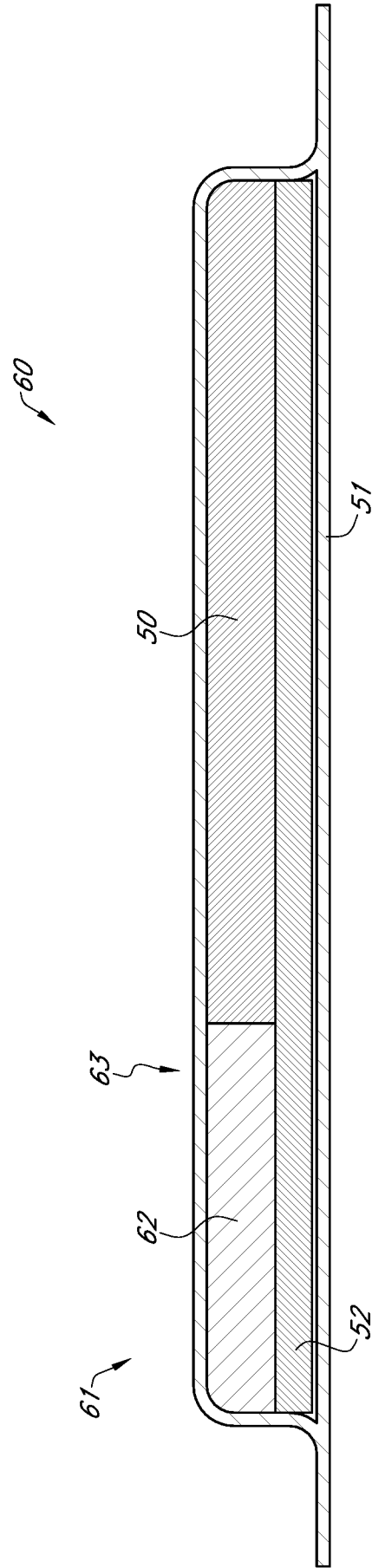

FIG. 1B

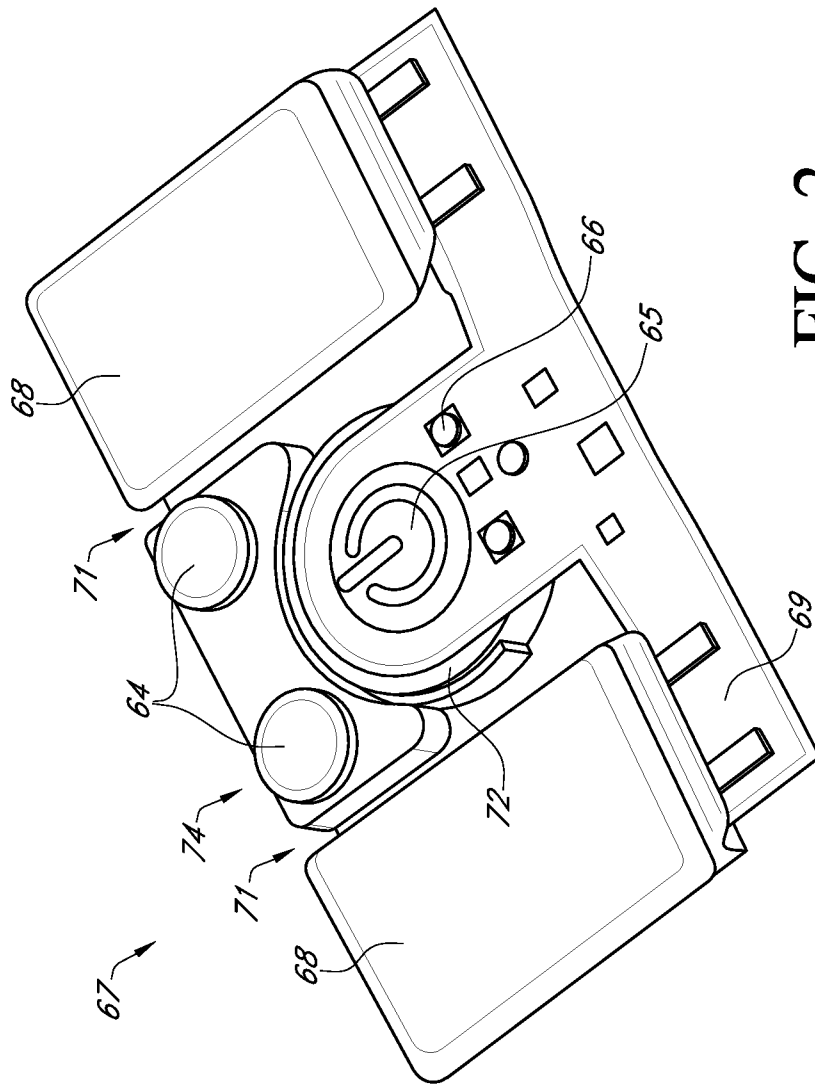

FIG. 2

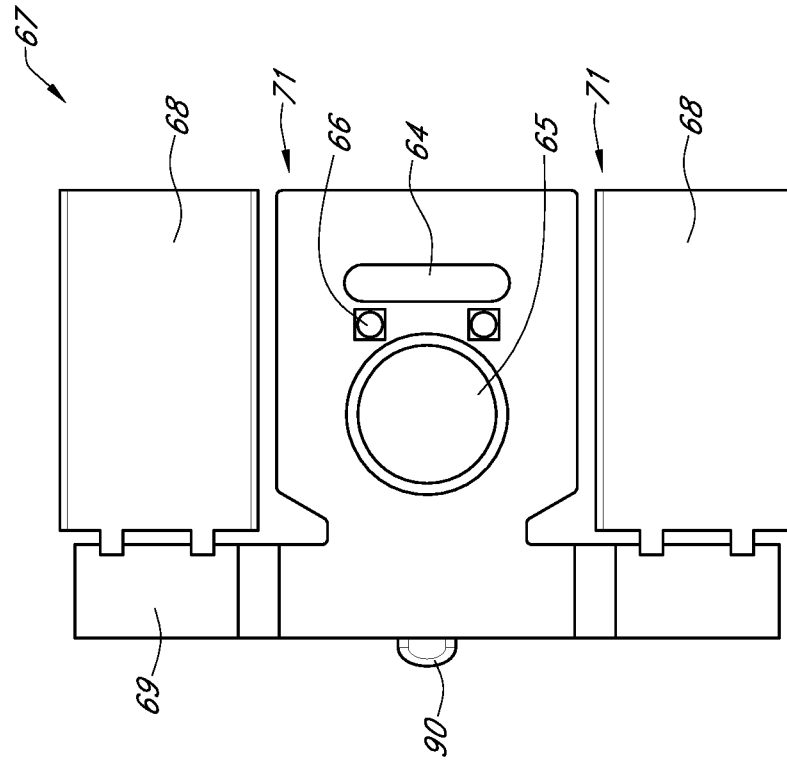

FIG. 3A

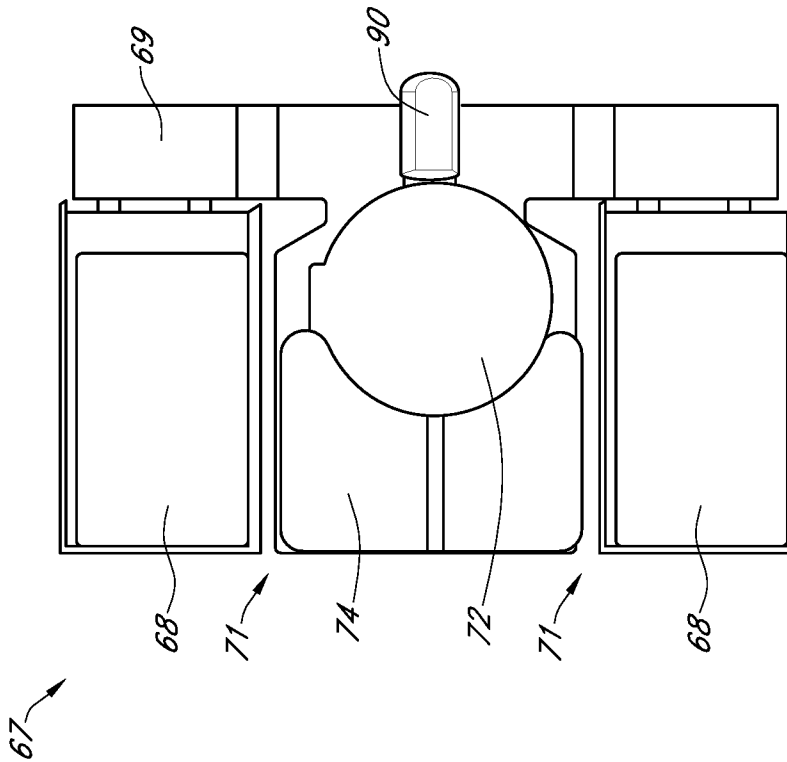

FIG. 3B

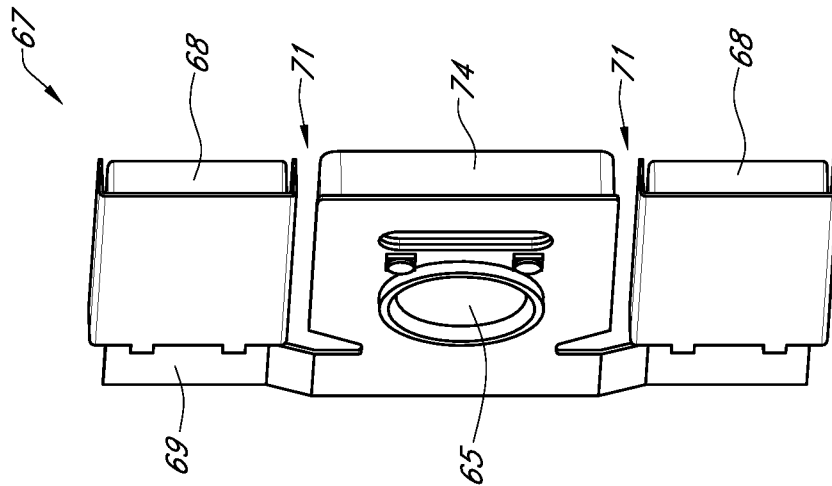

FIG. 3D

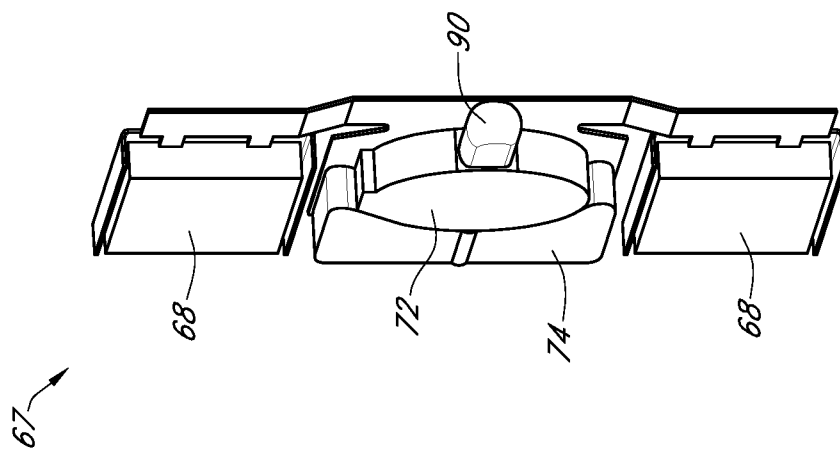

FIG. 3C

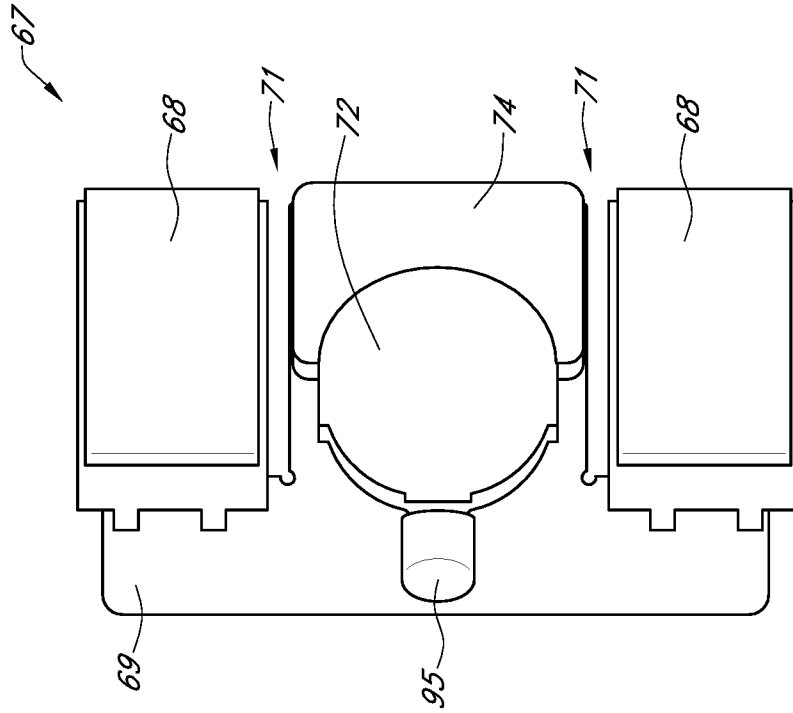

FIG. 4B

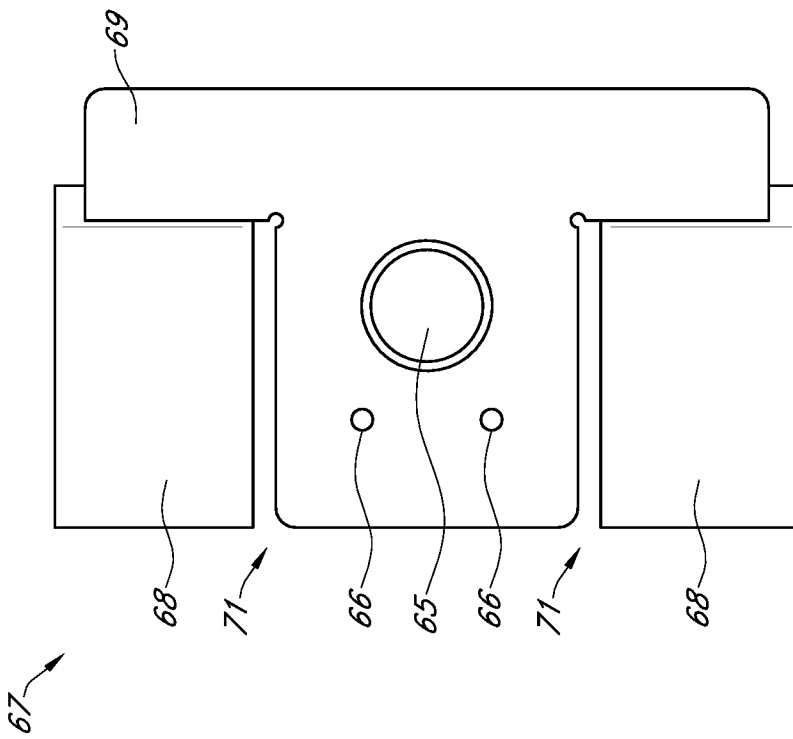

FIG. 4A

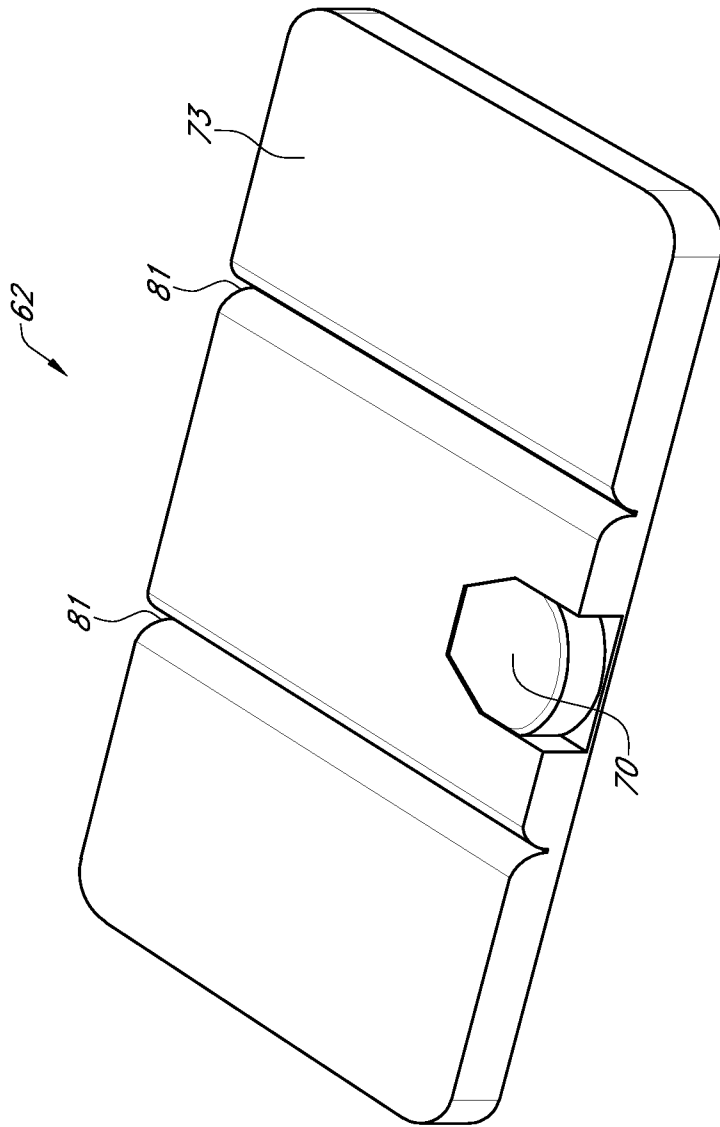

FIG. 5A

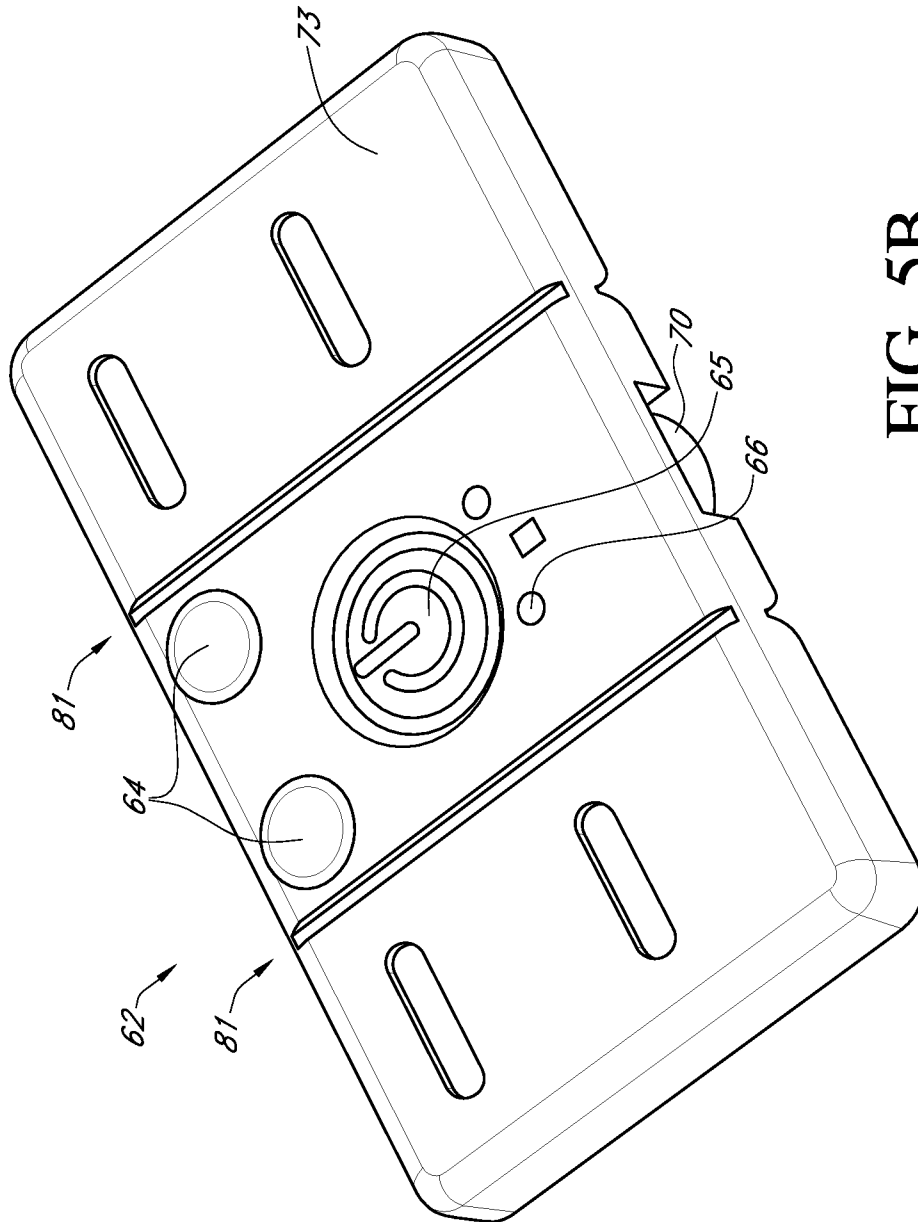

FIG. 5B

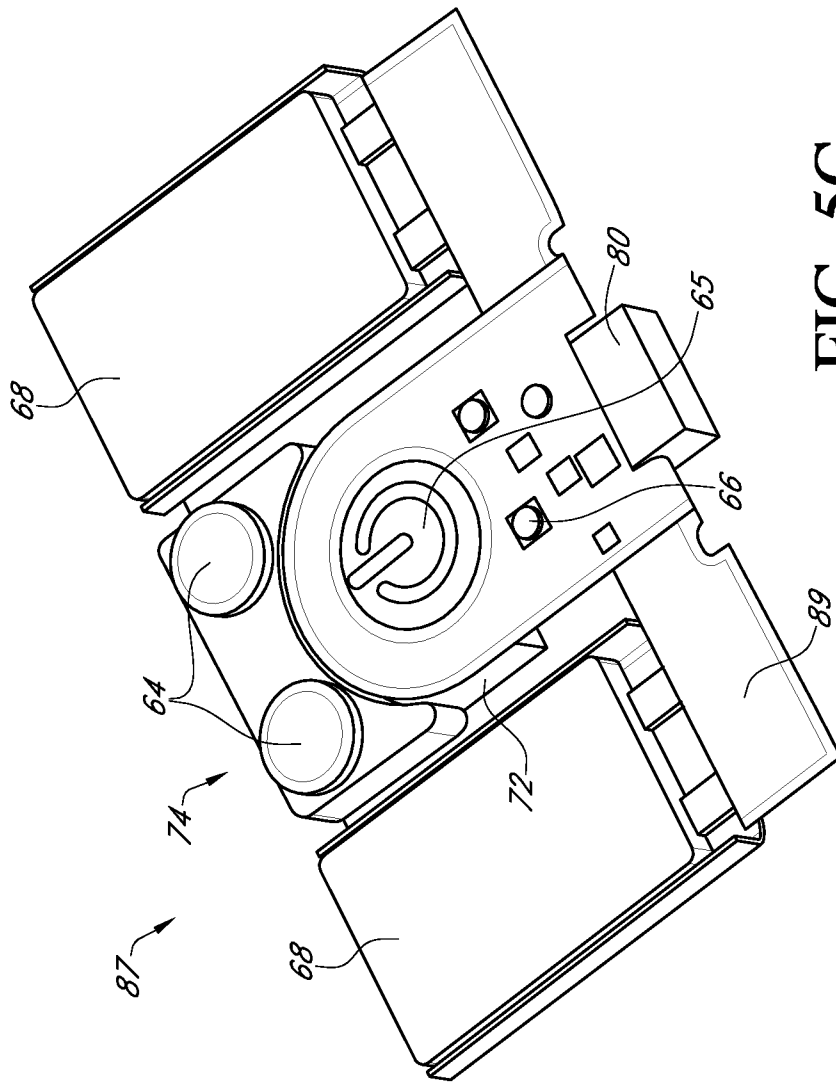

FIG. 5C

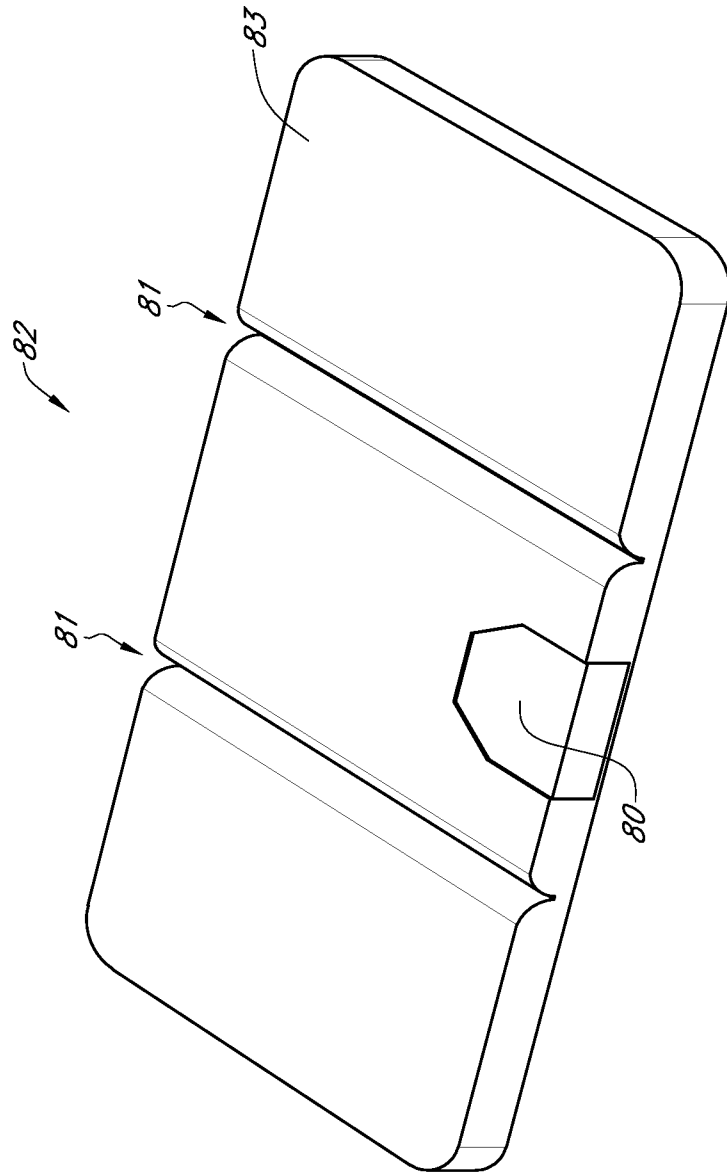

FIG. 5D

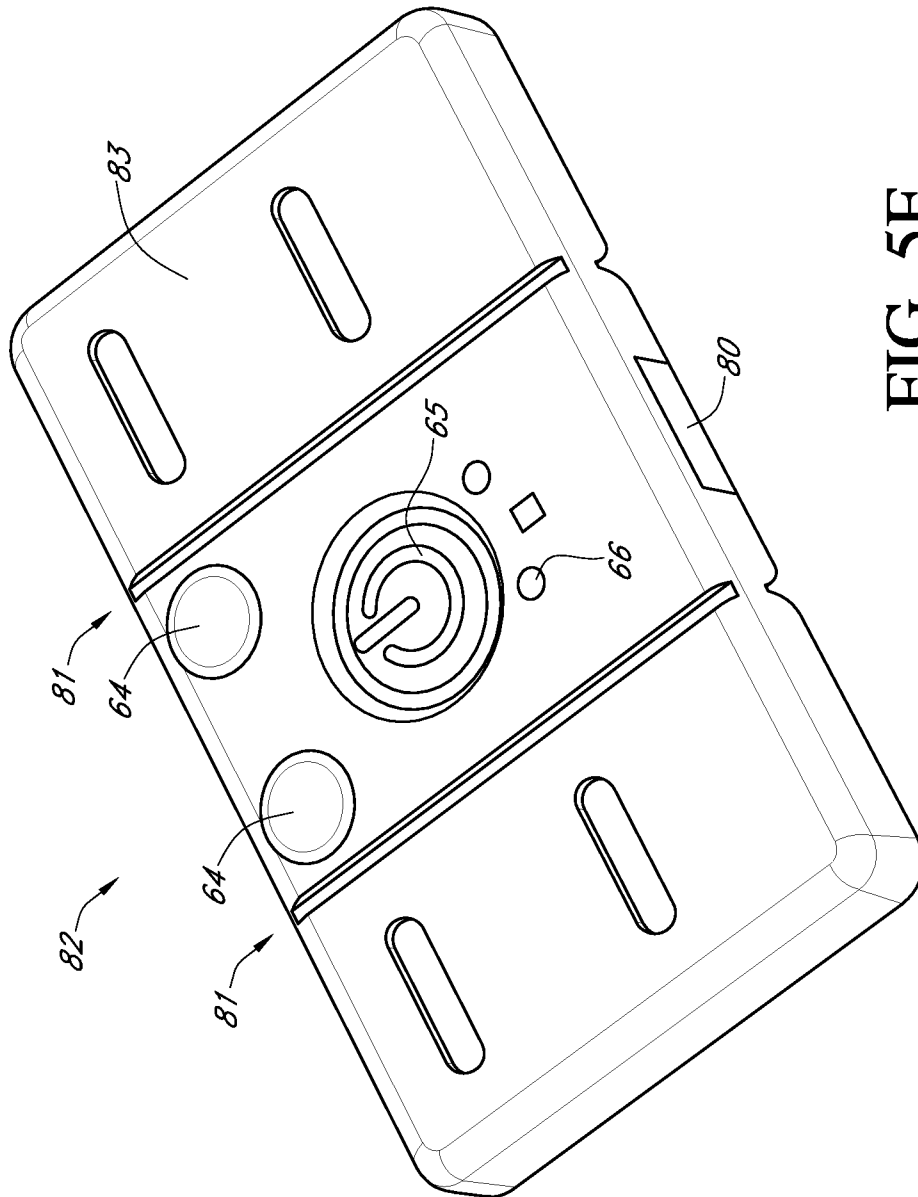

FIG. 5E

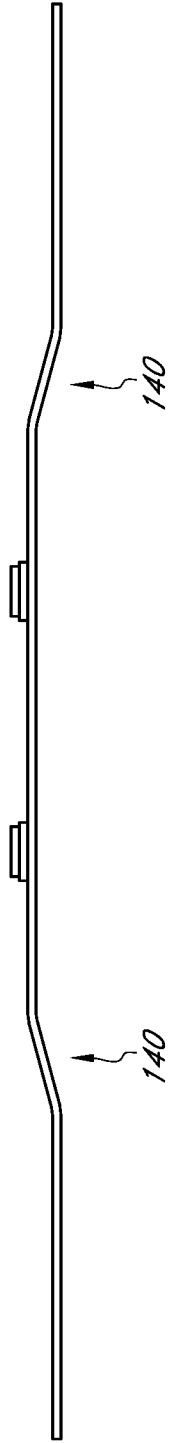

FIG. 6A

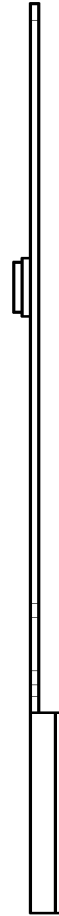

FIG. 6B

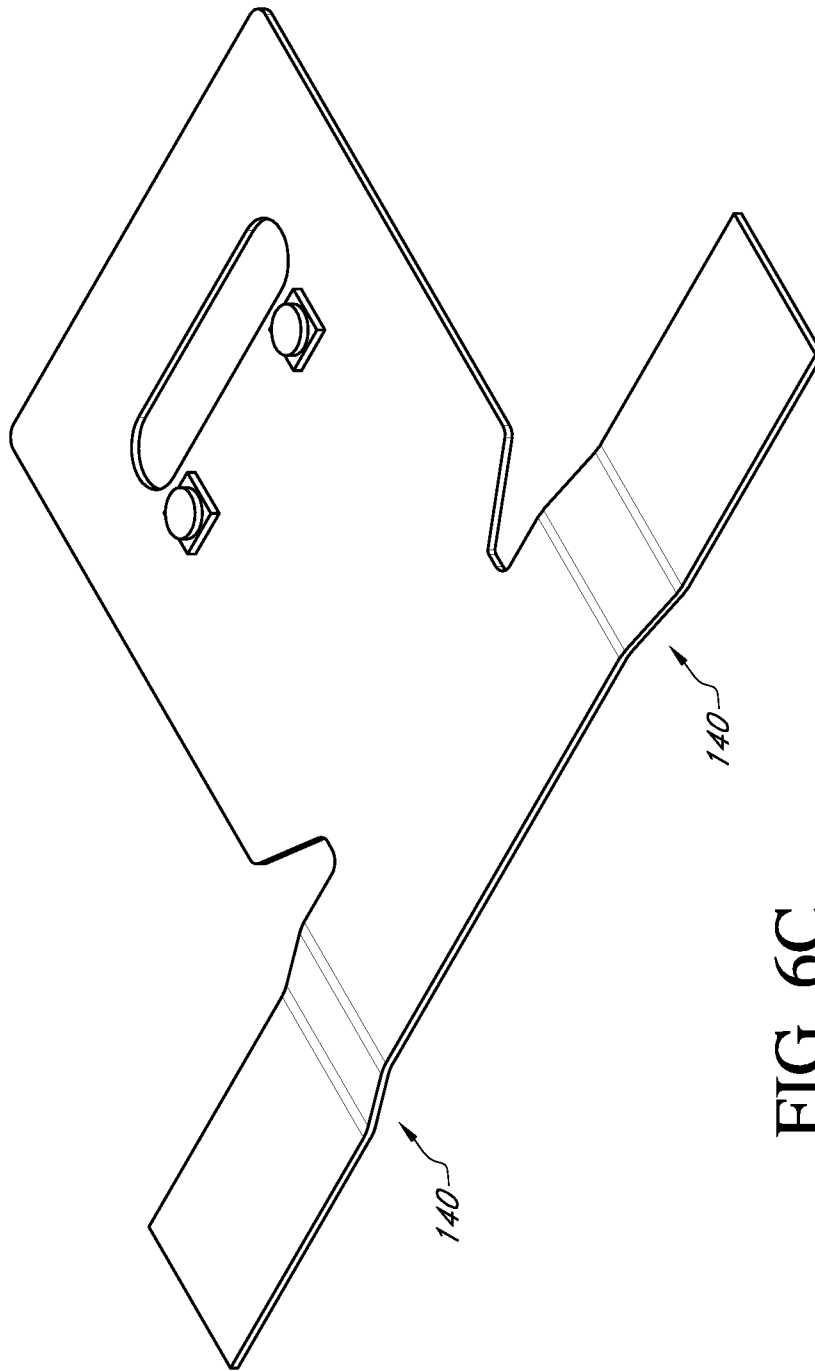

FIG. 6C

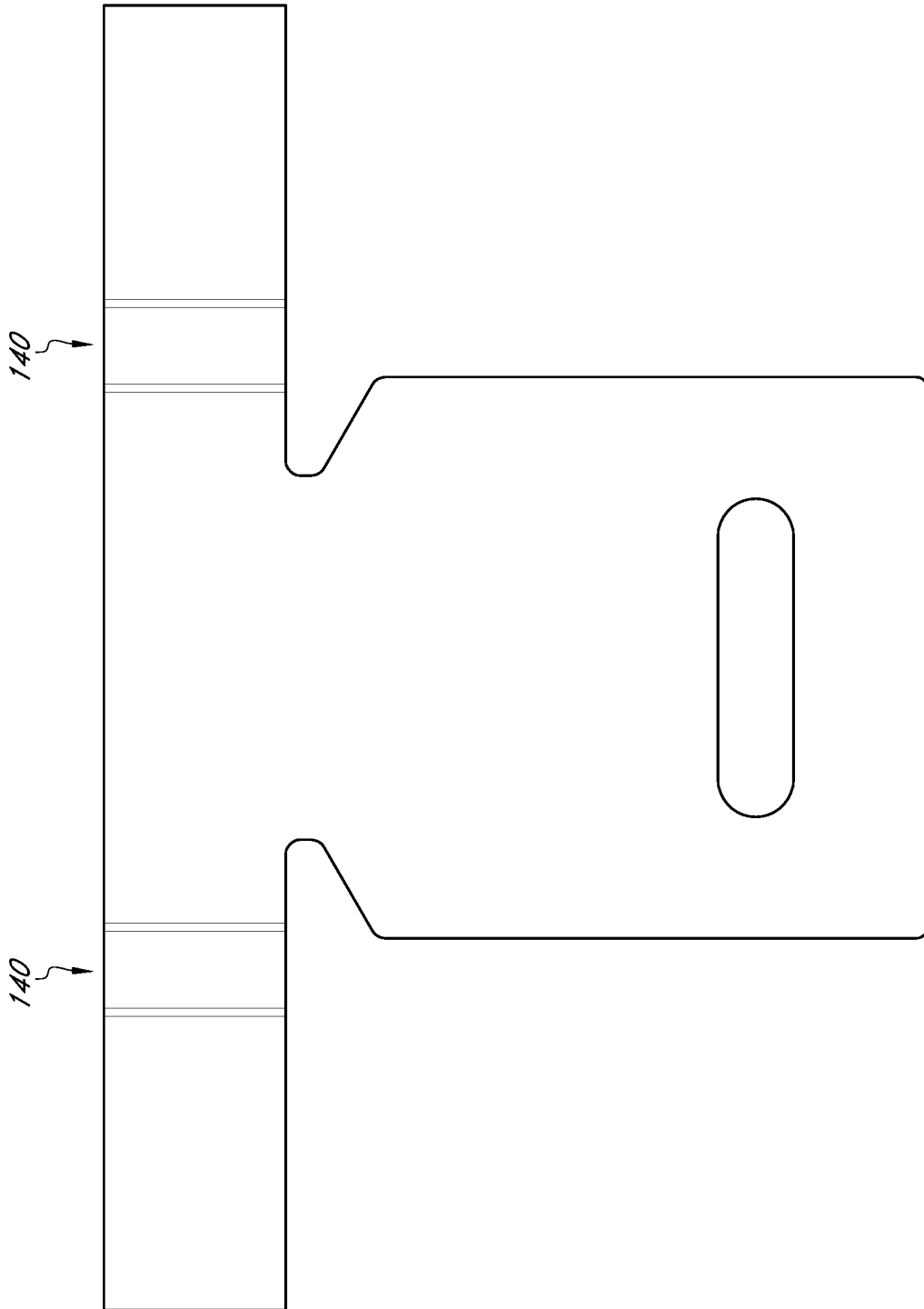

FIG. 6D

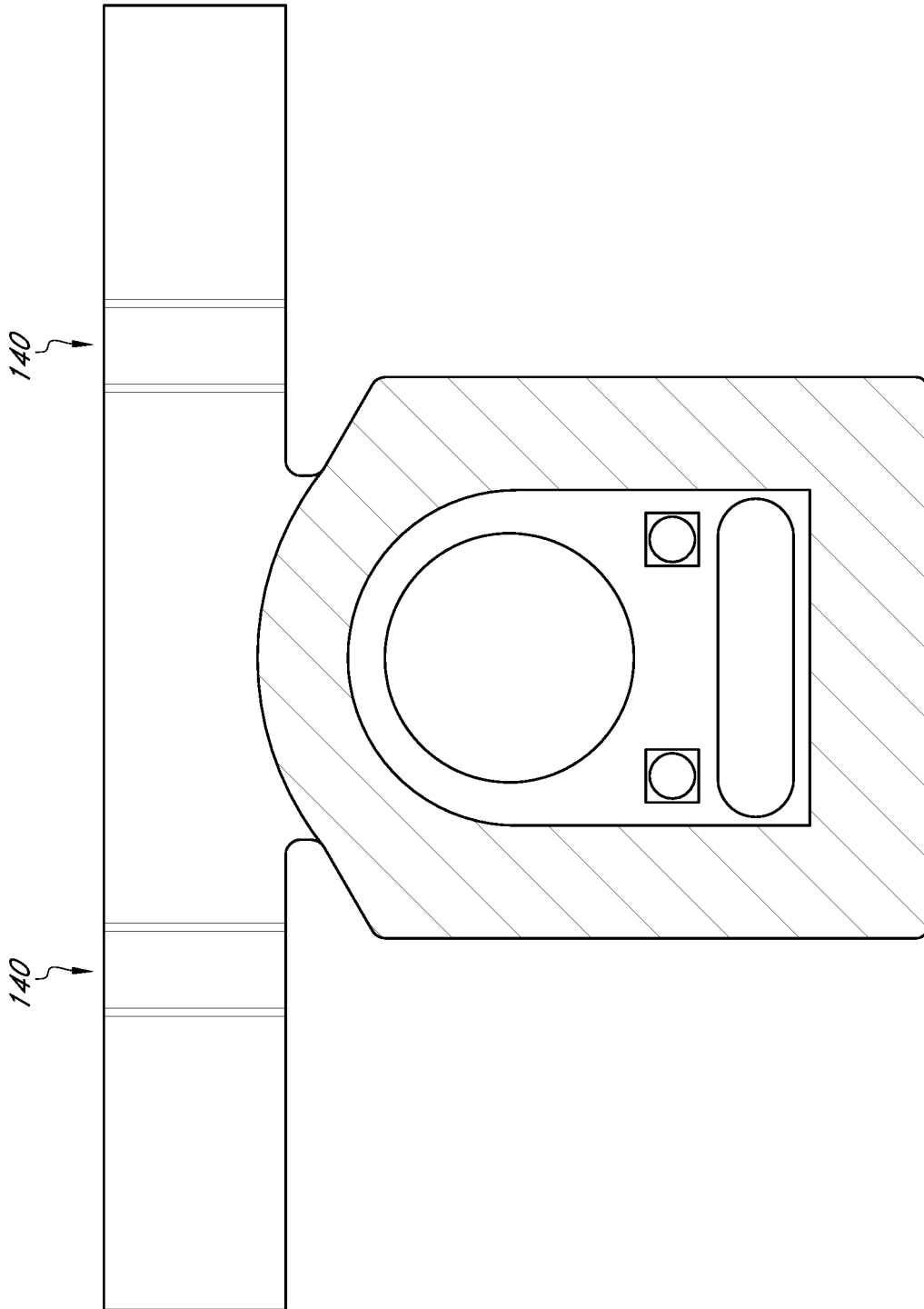

FIG. 6E

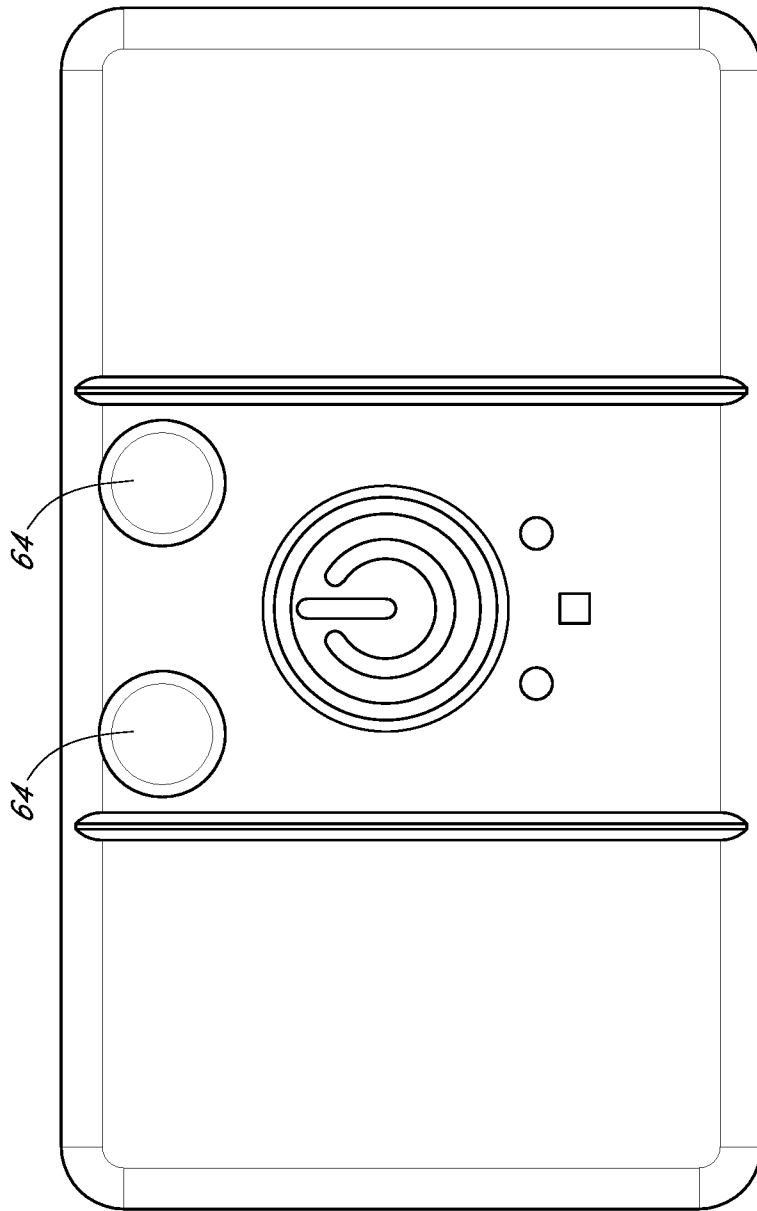

FIG. 7A

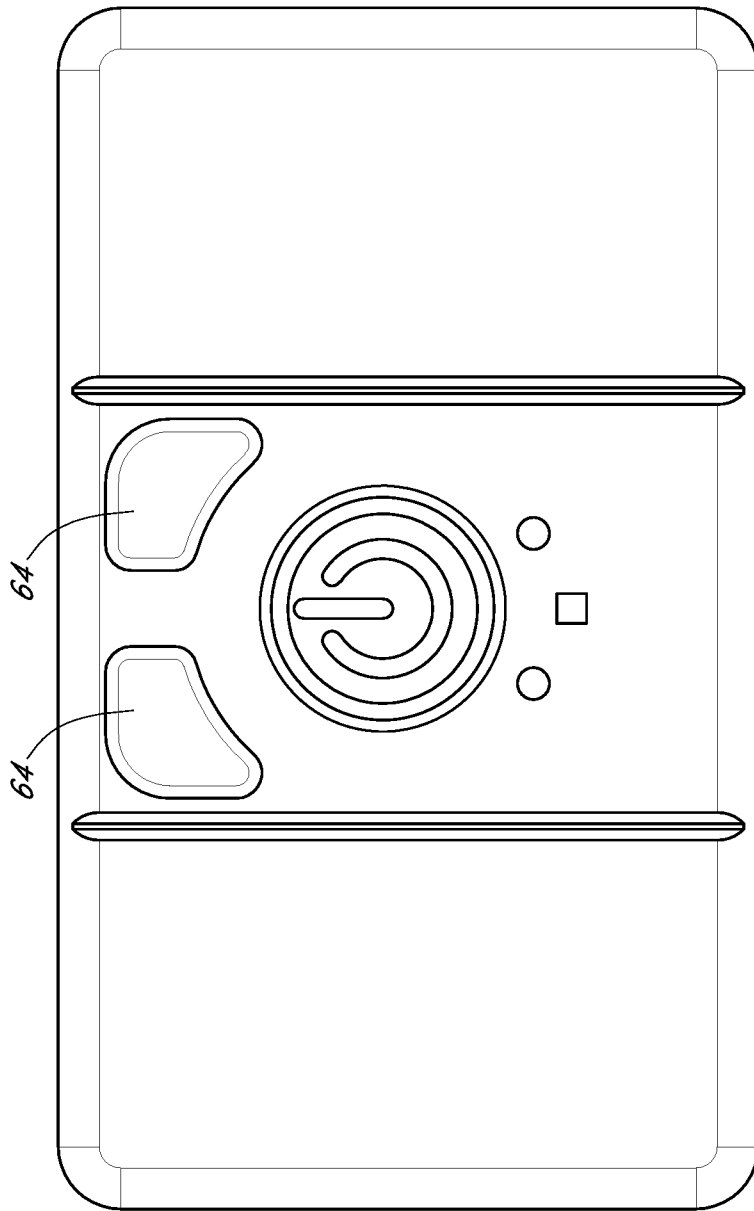

FIG. 7B

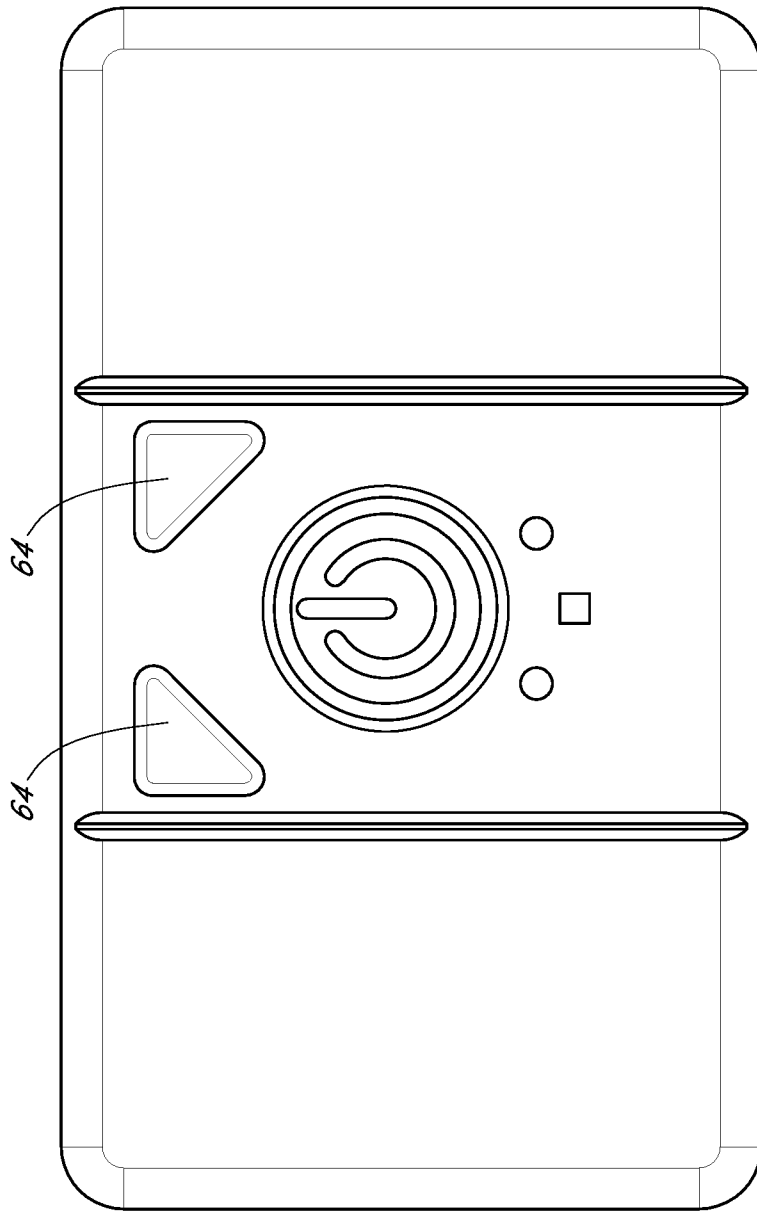

FIG. 7C

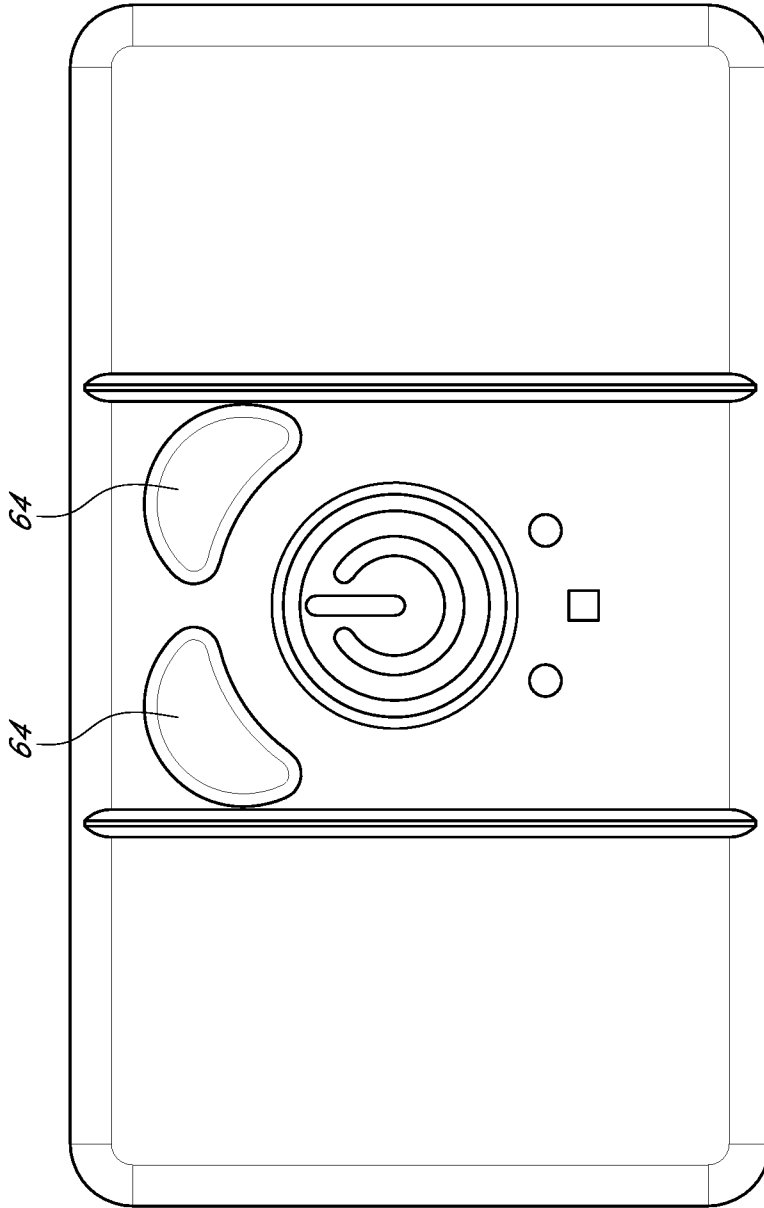

FIG. 7D

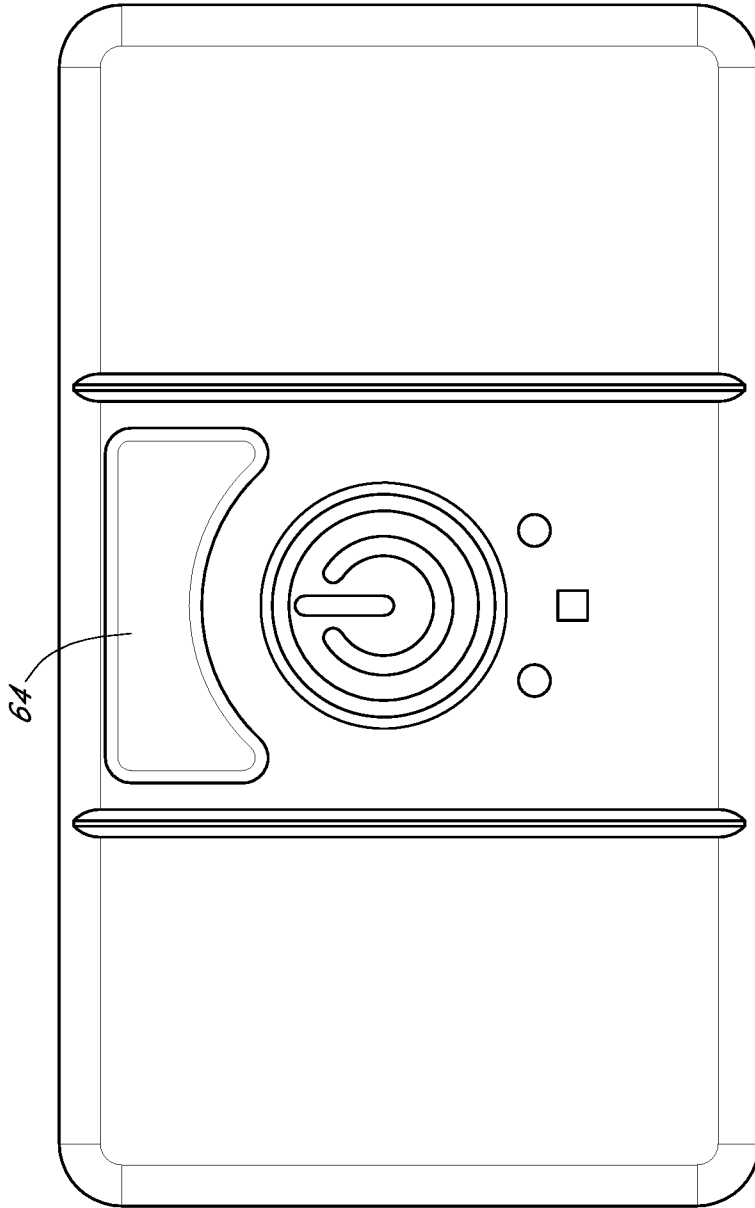

FIG. 8A

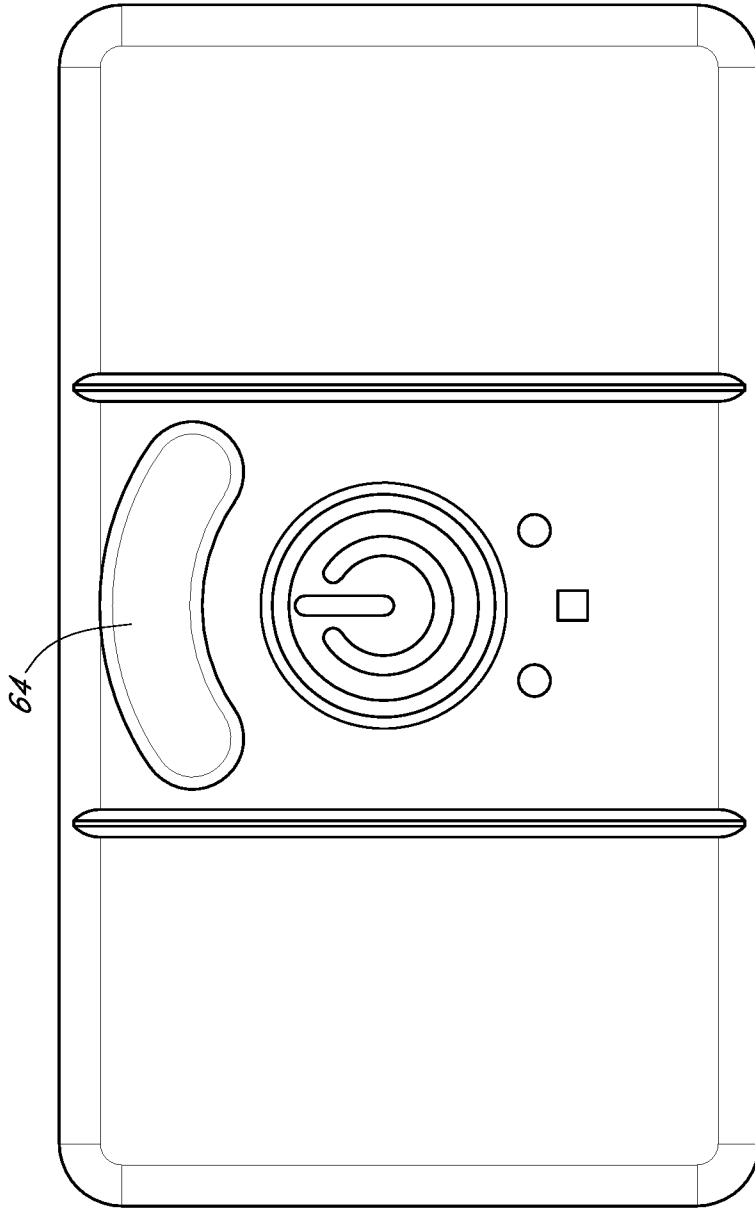

FIG. 8B

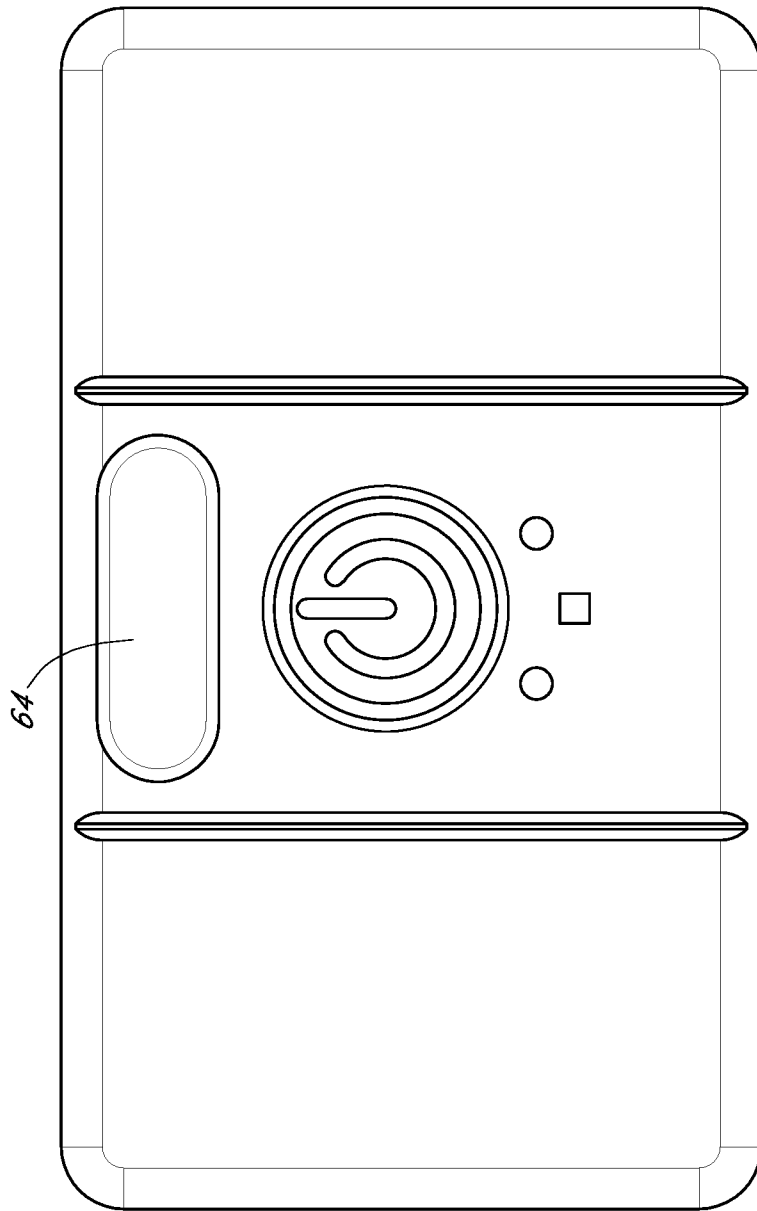

FIG. 8C

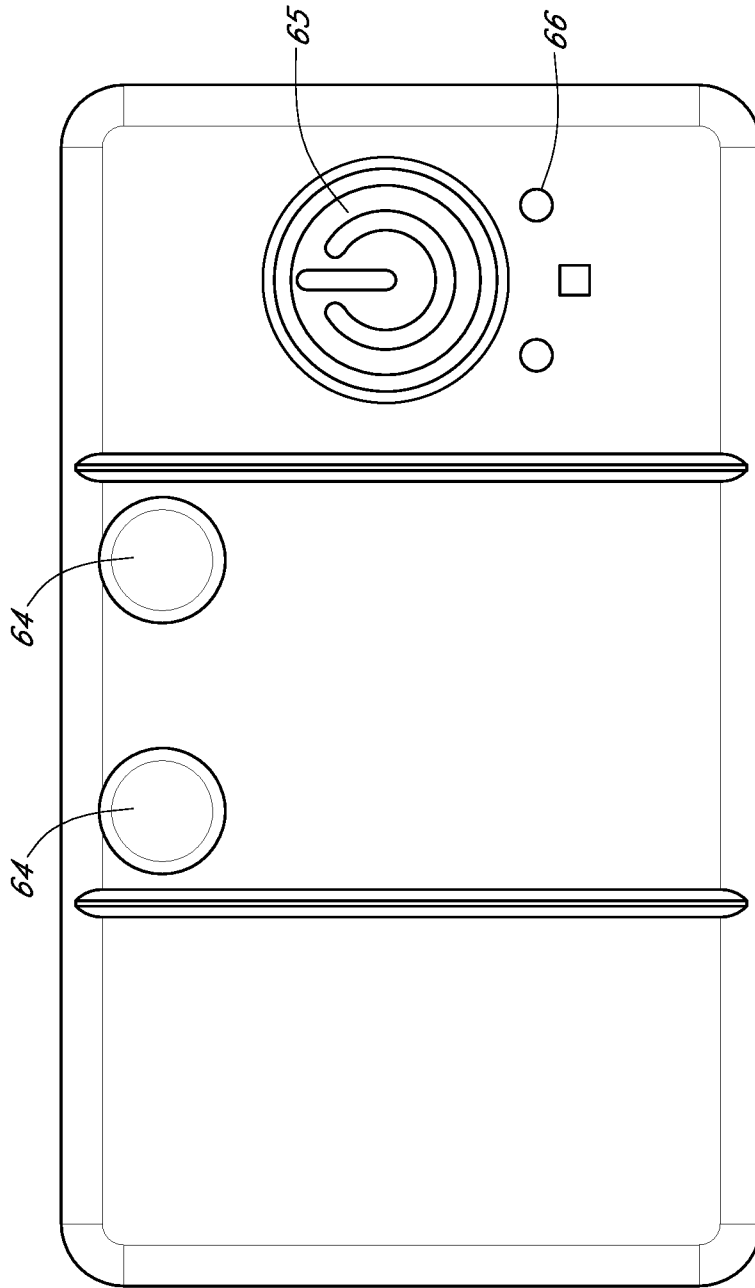

FIG. 9A

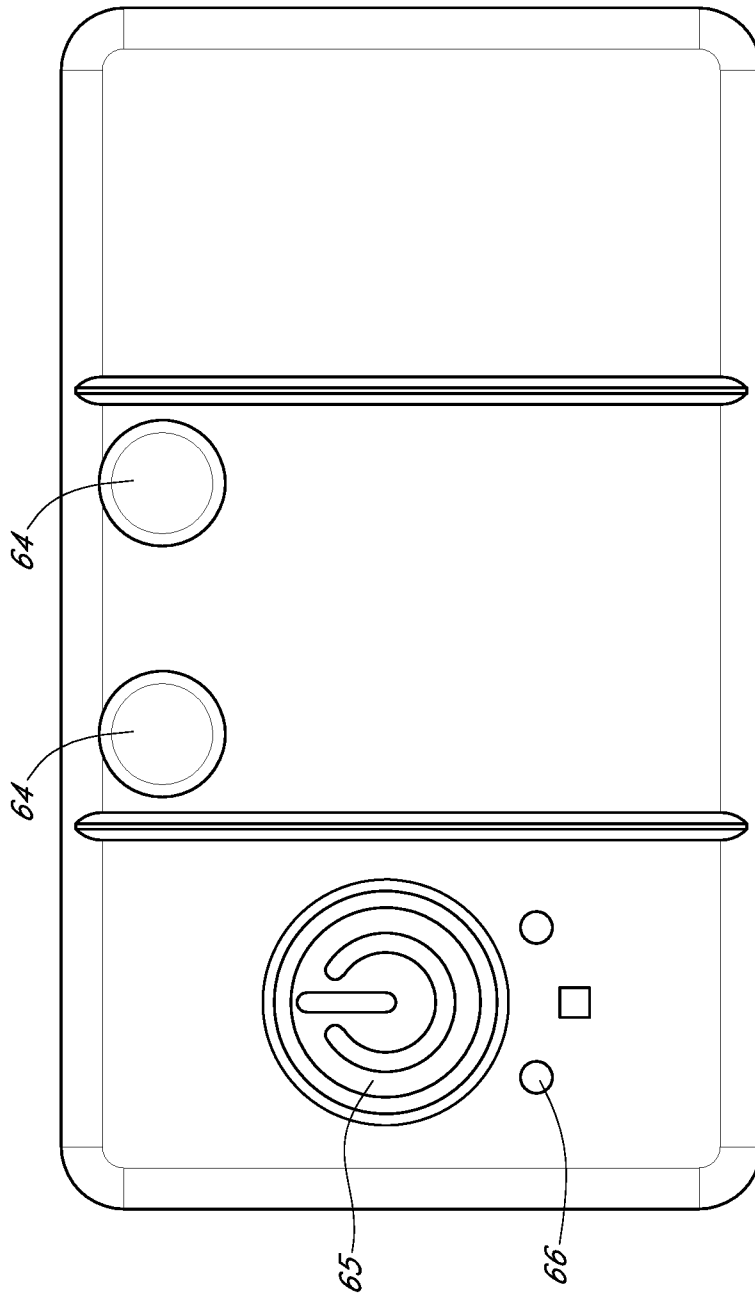

FIG. 9B

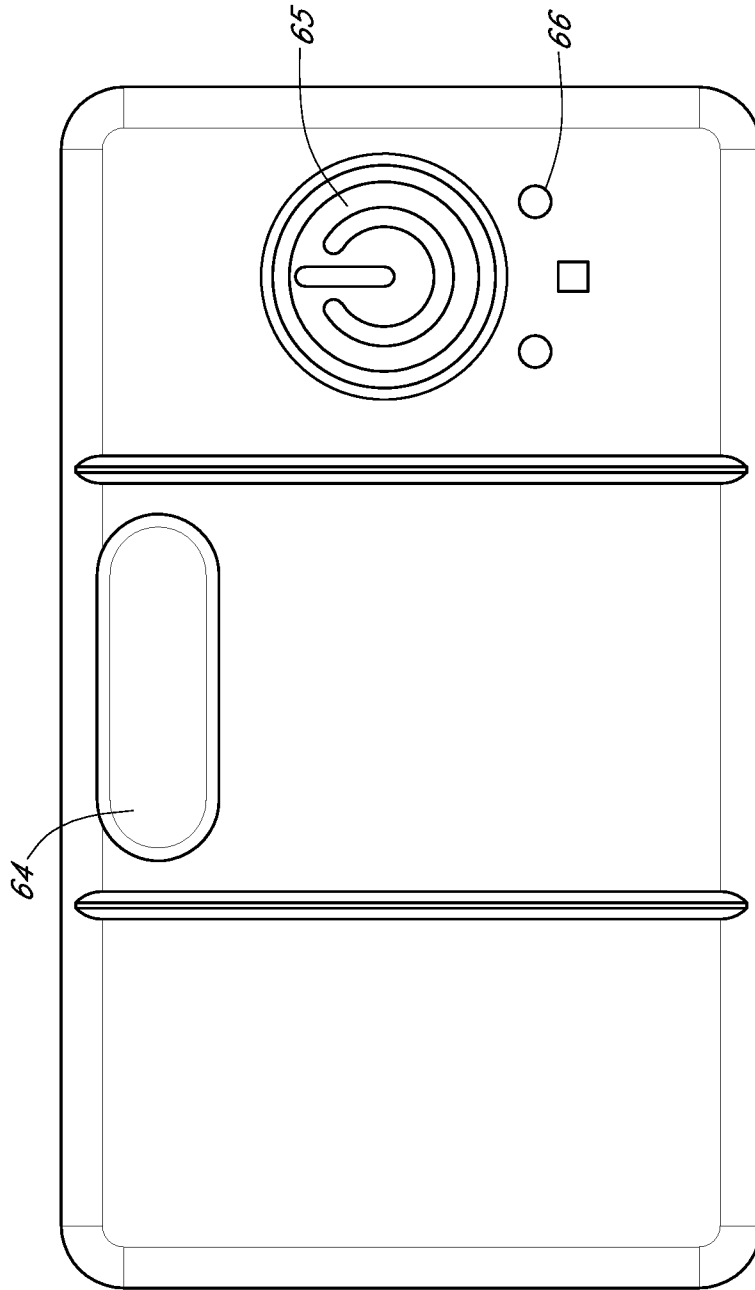

FIG. 9C

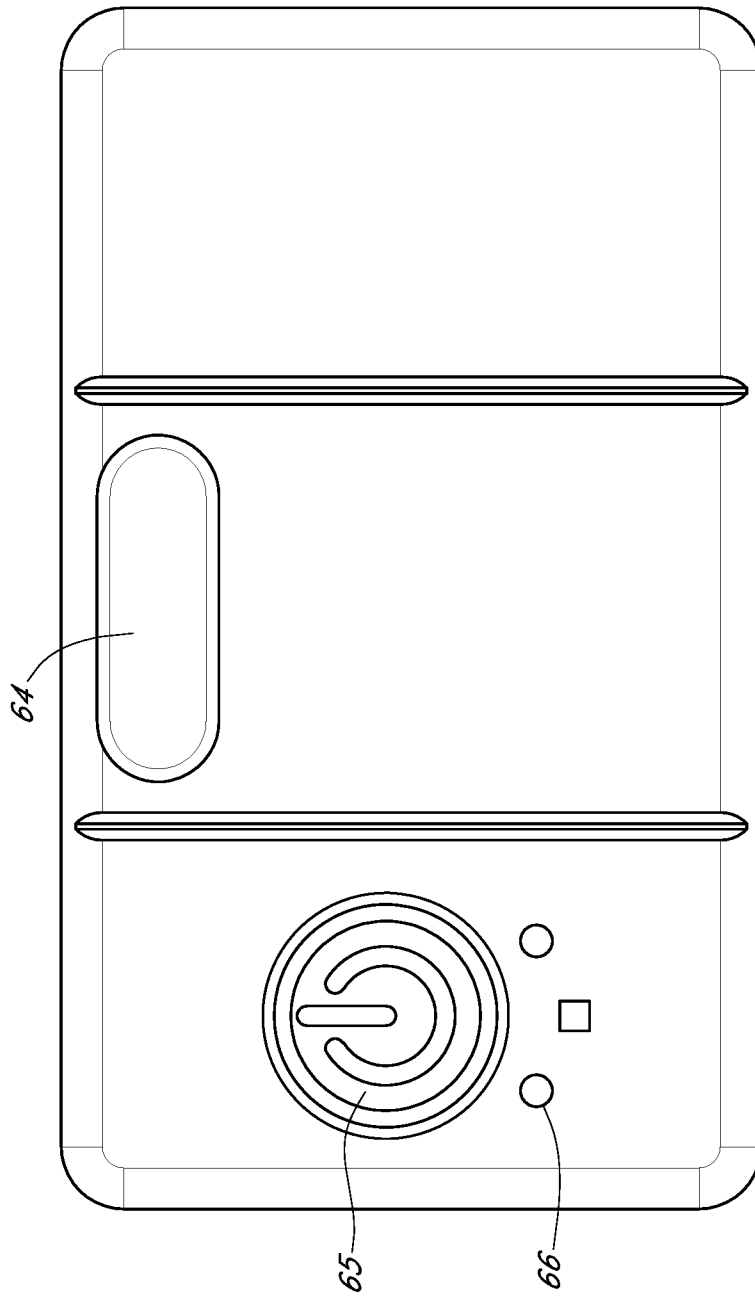

FIG. 9D

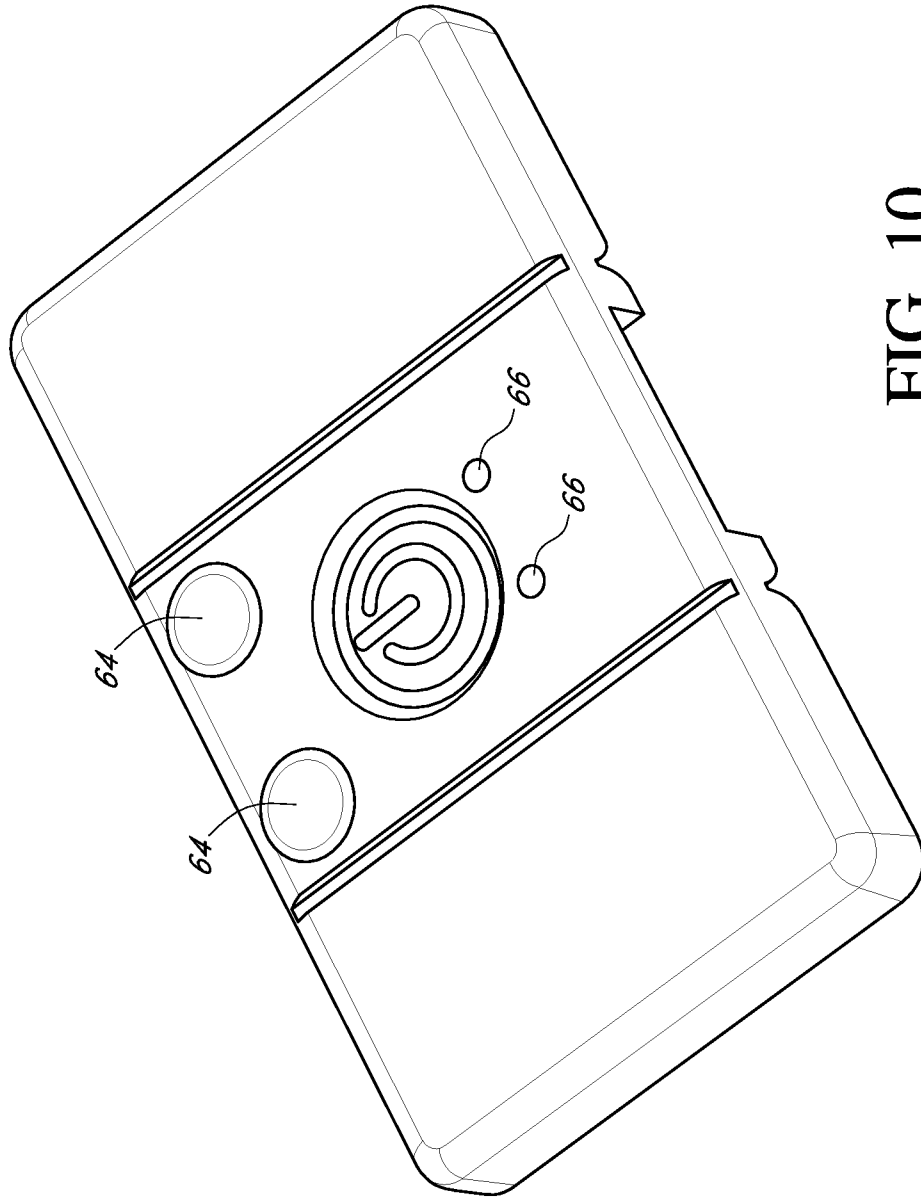

FIG. 10

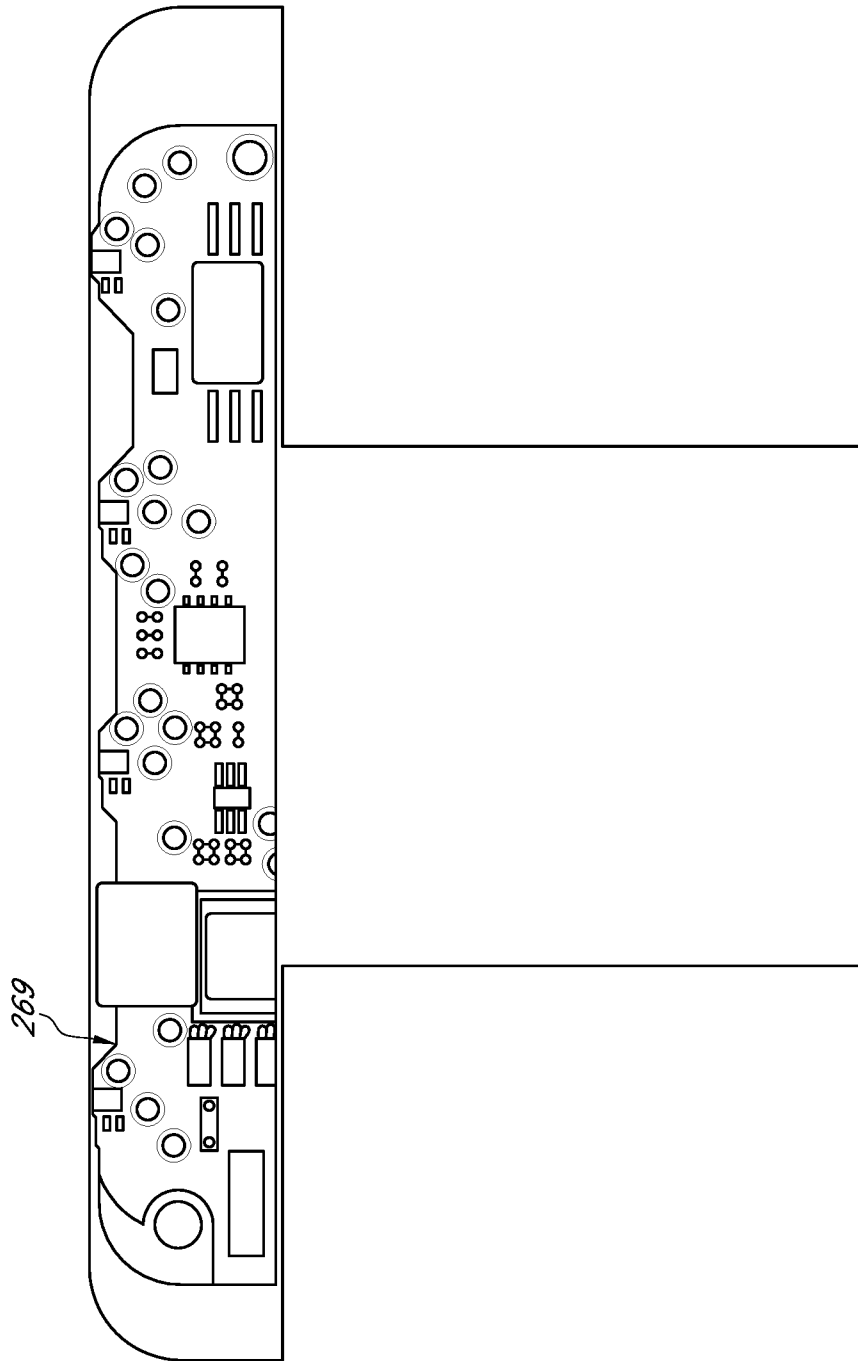

FIG. 11

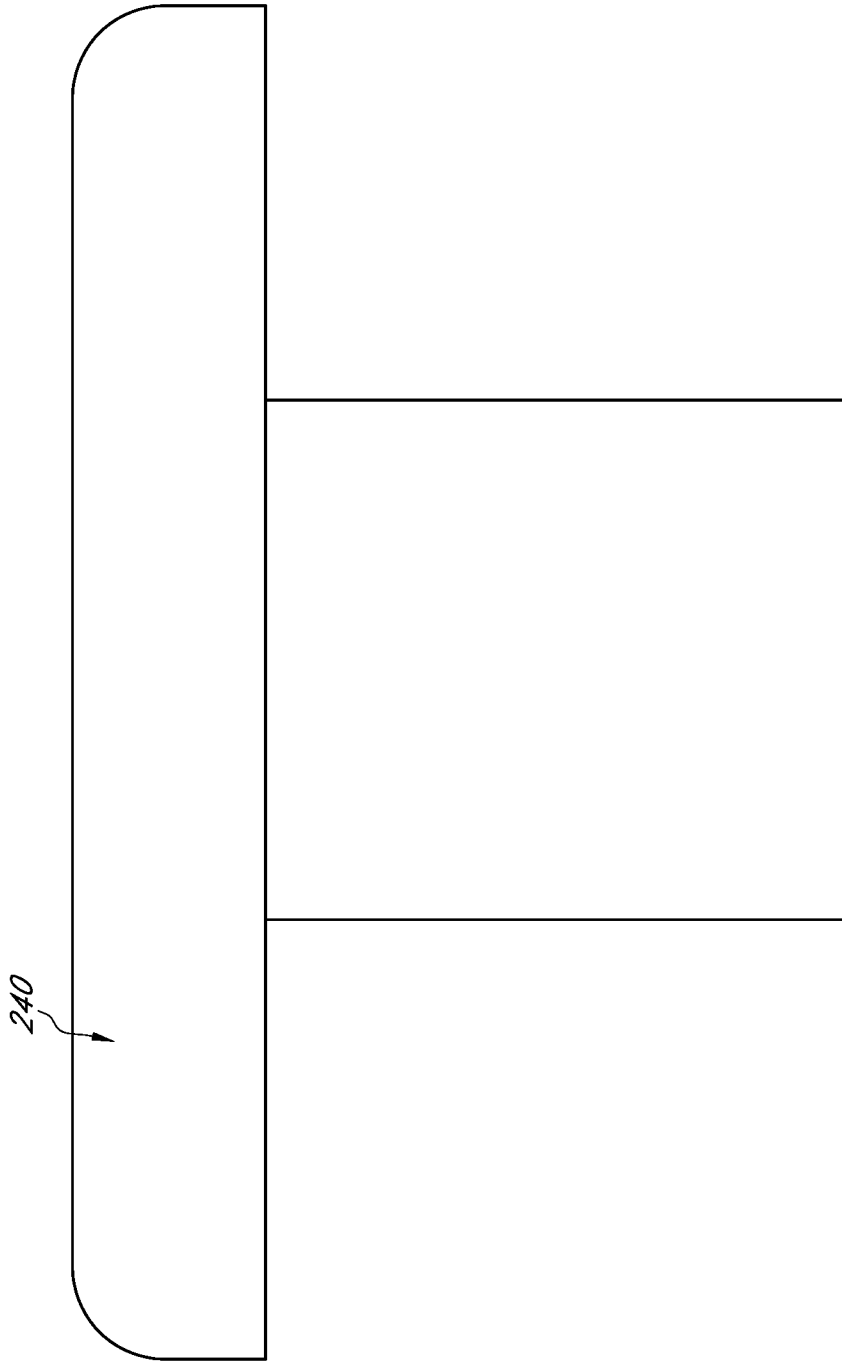

FIG. 12

30/54

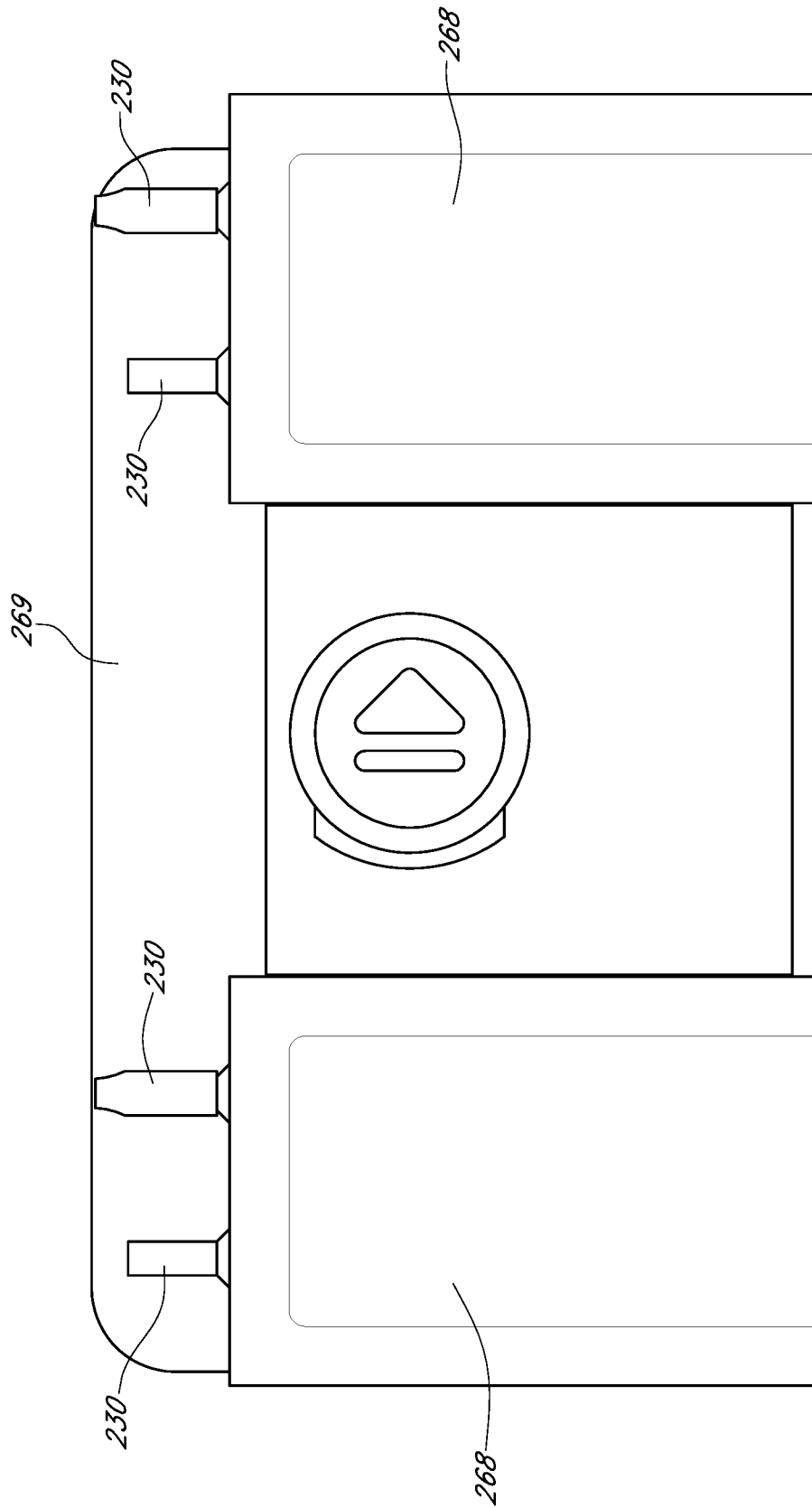

FIG. 13

31/54

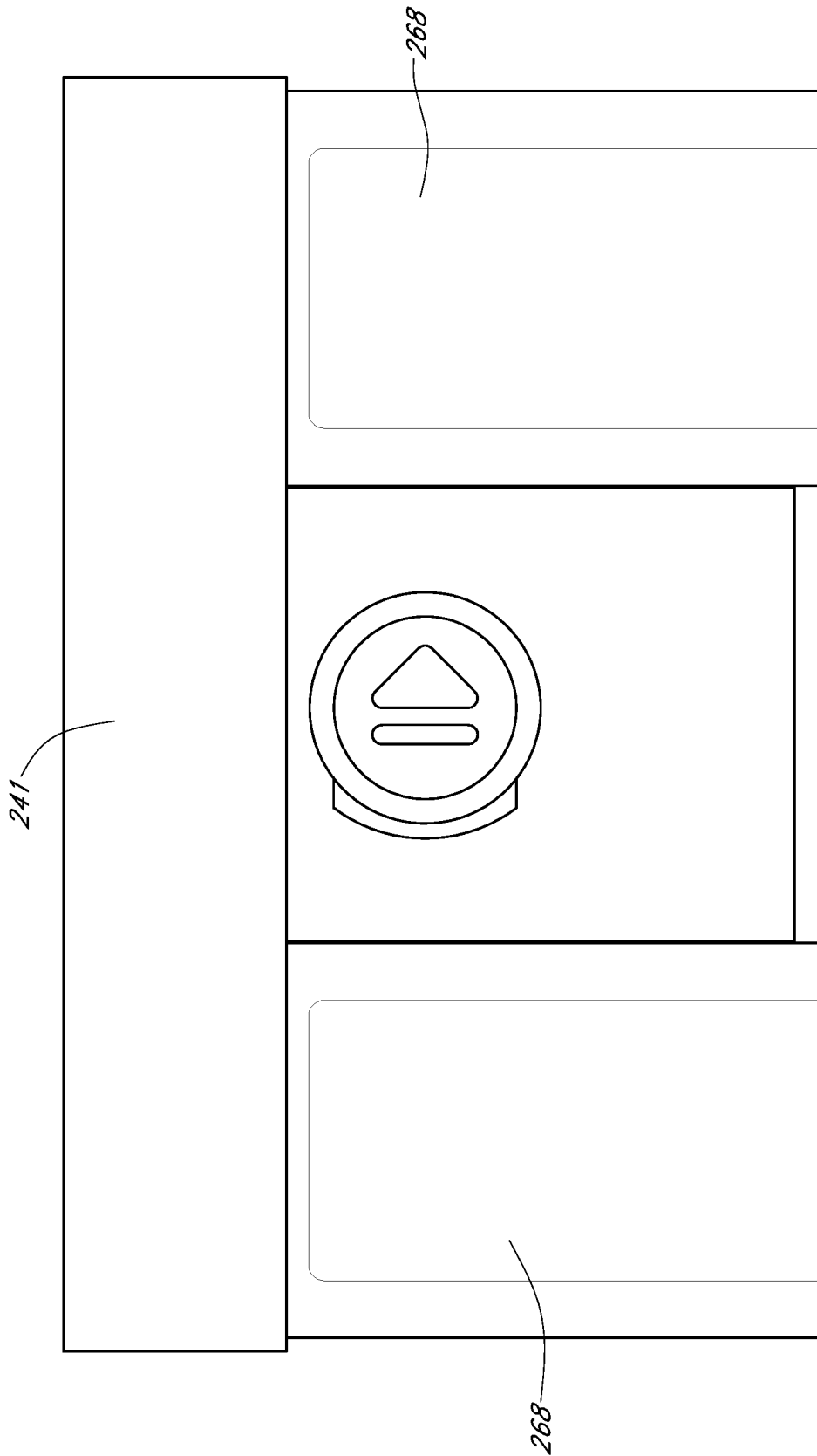

FIG. 14

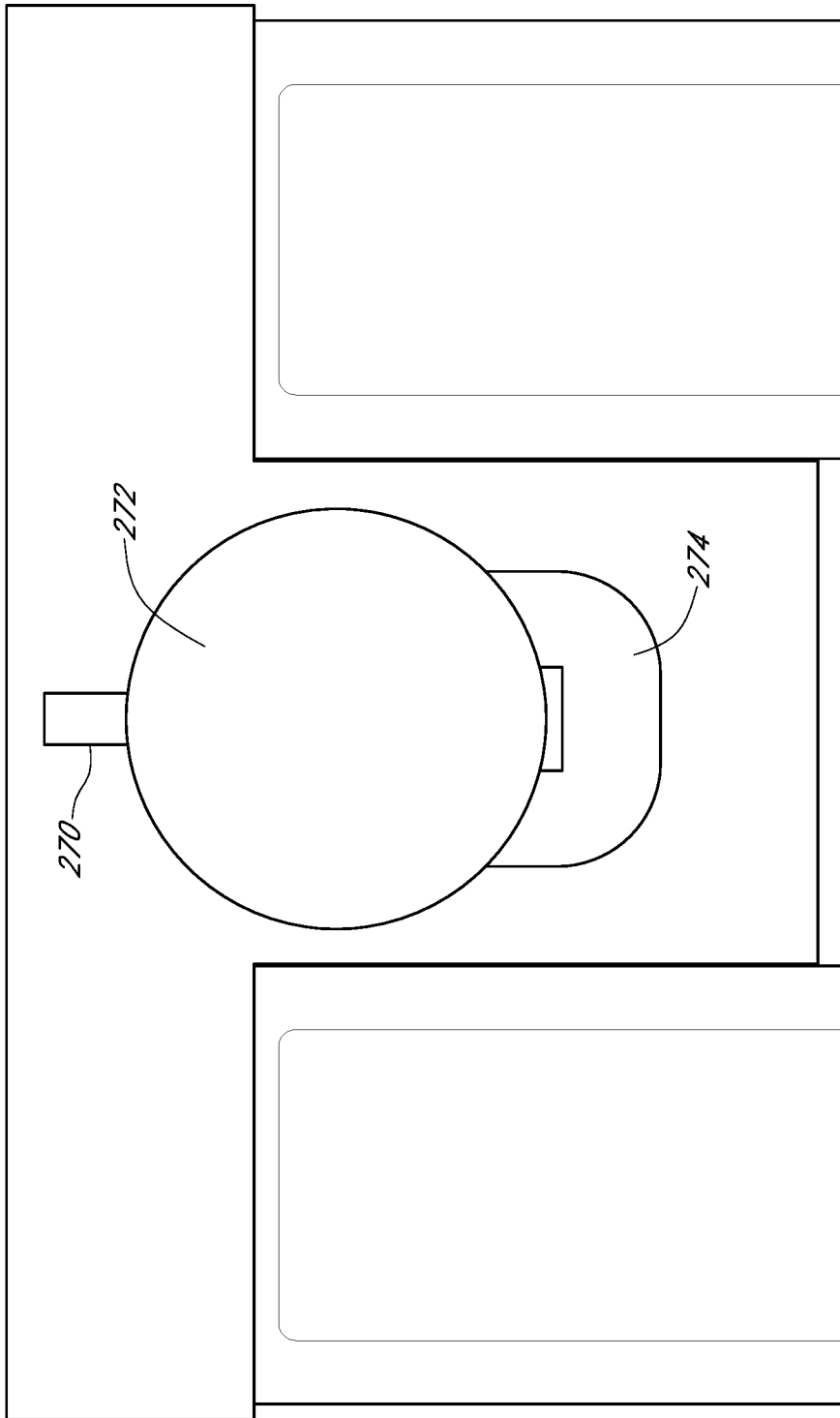

FIG. 15

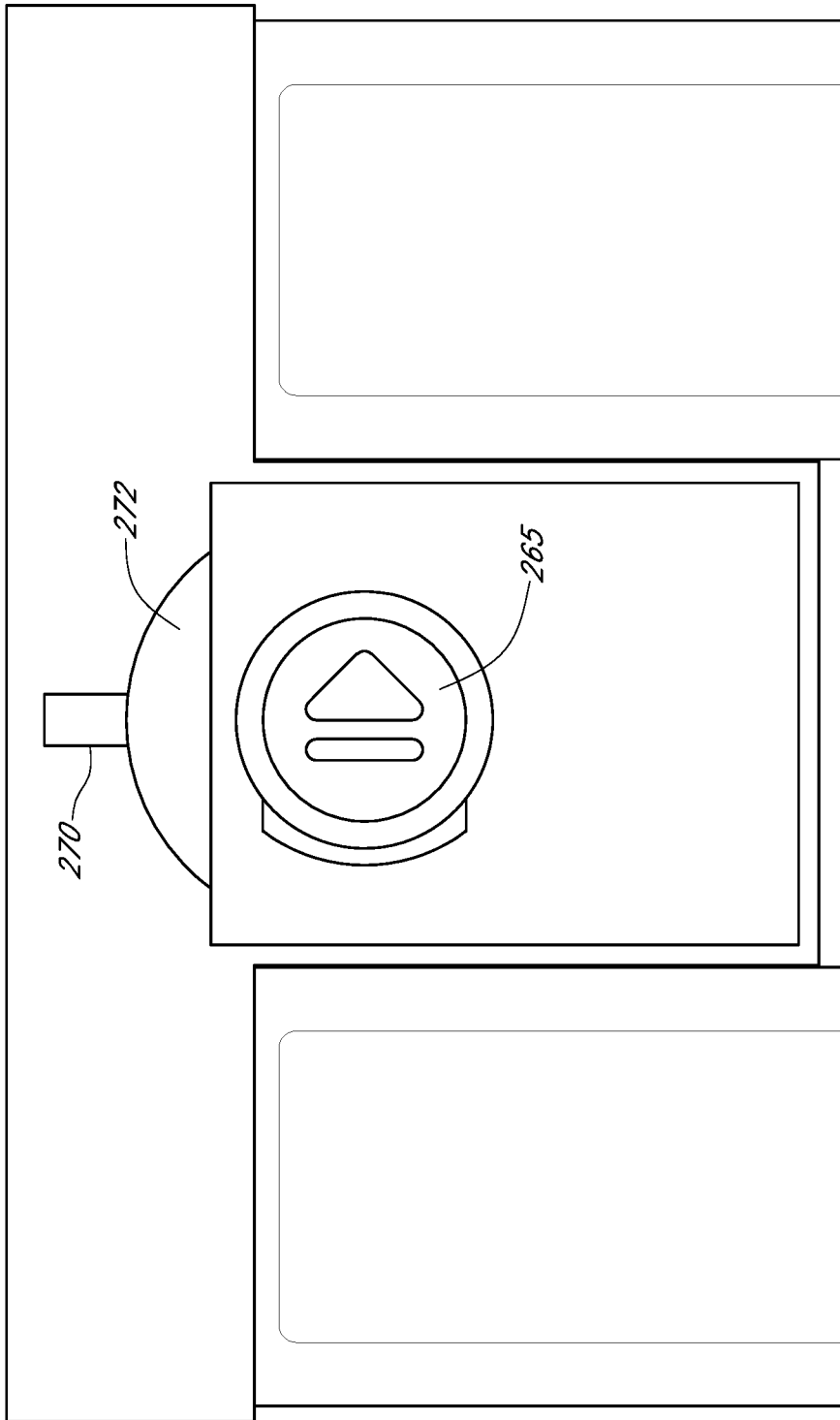

FIG. 16

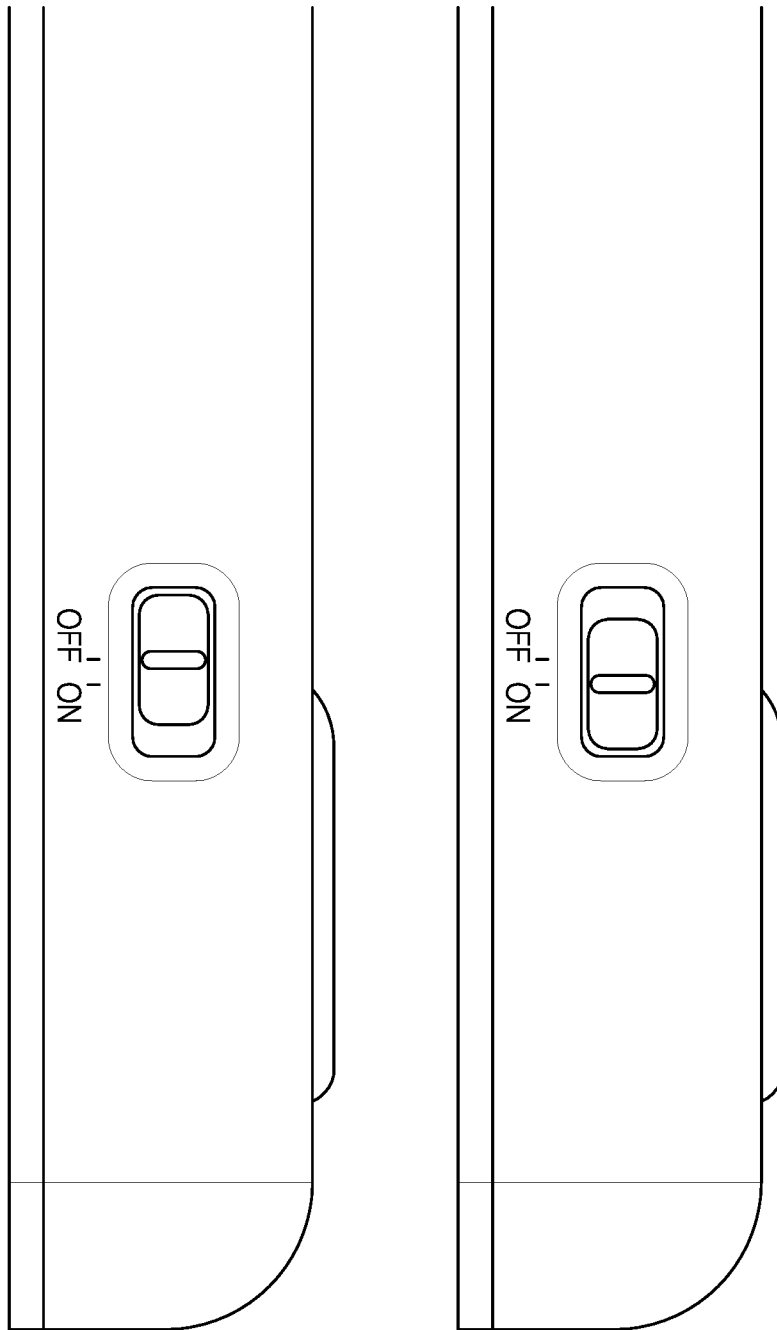

FIG. 17

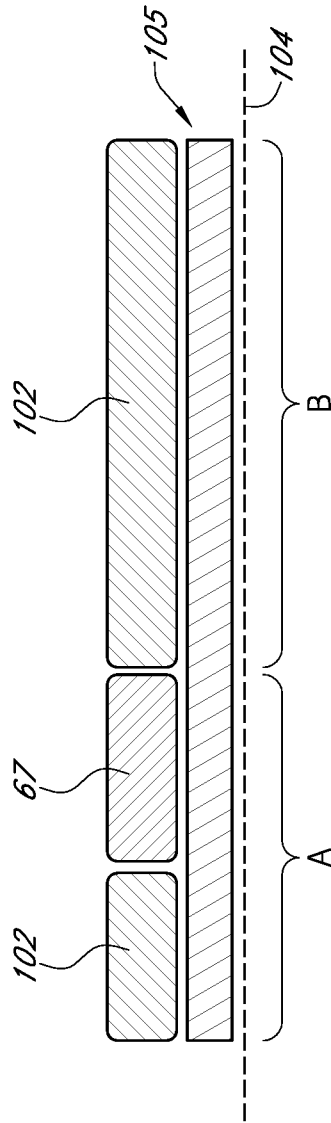

FIG. 18

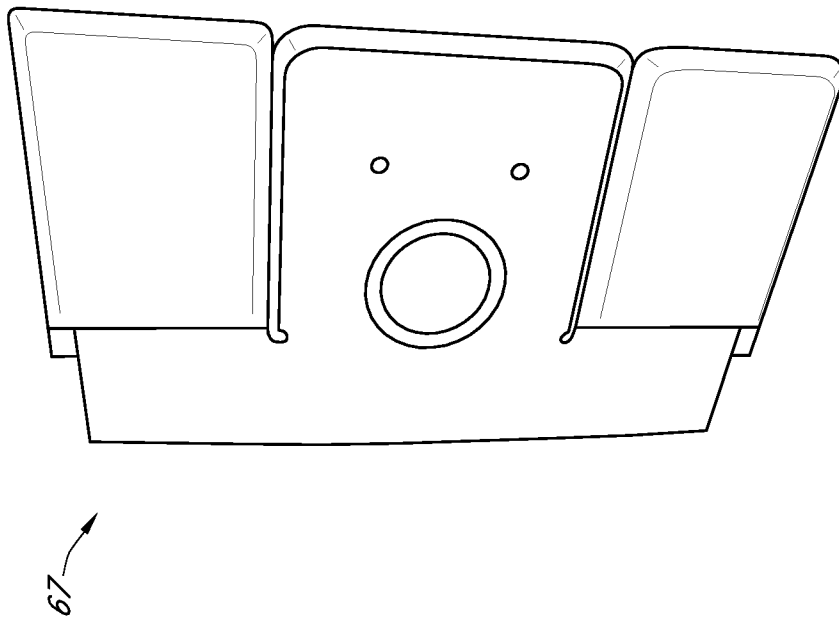

FIG. 19A

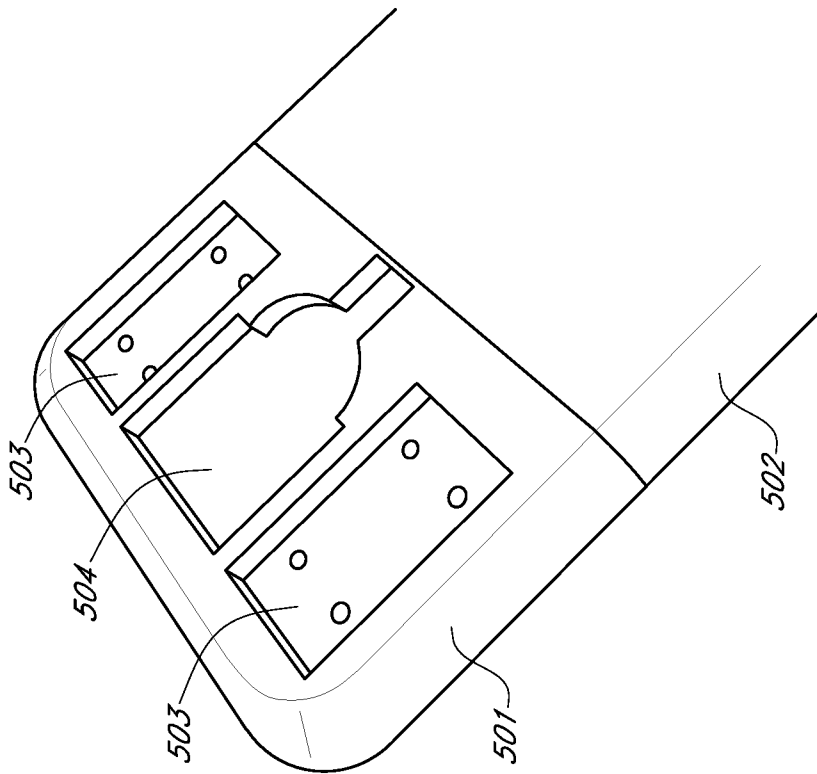

FIG. 19B

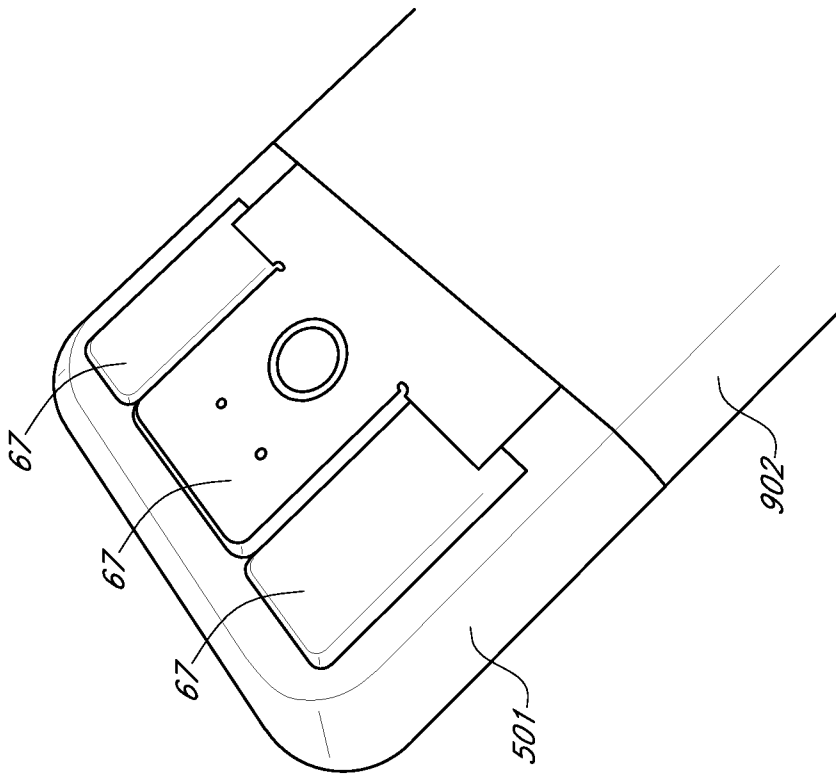

FIG. 19C

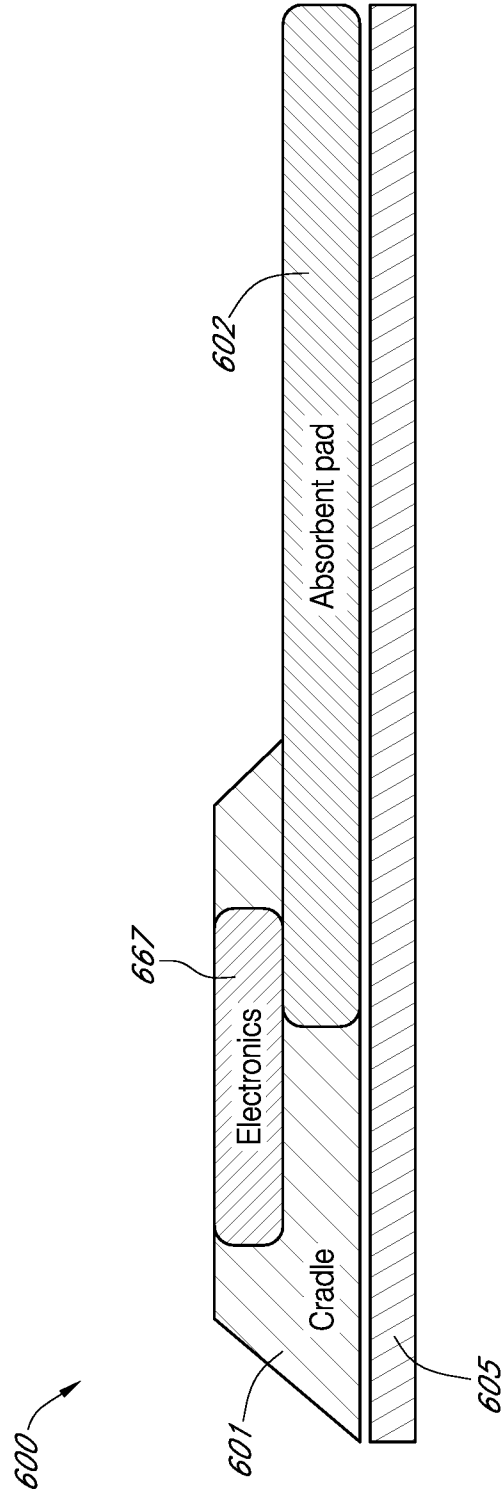

FIG. 20A

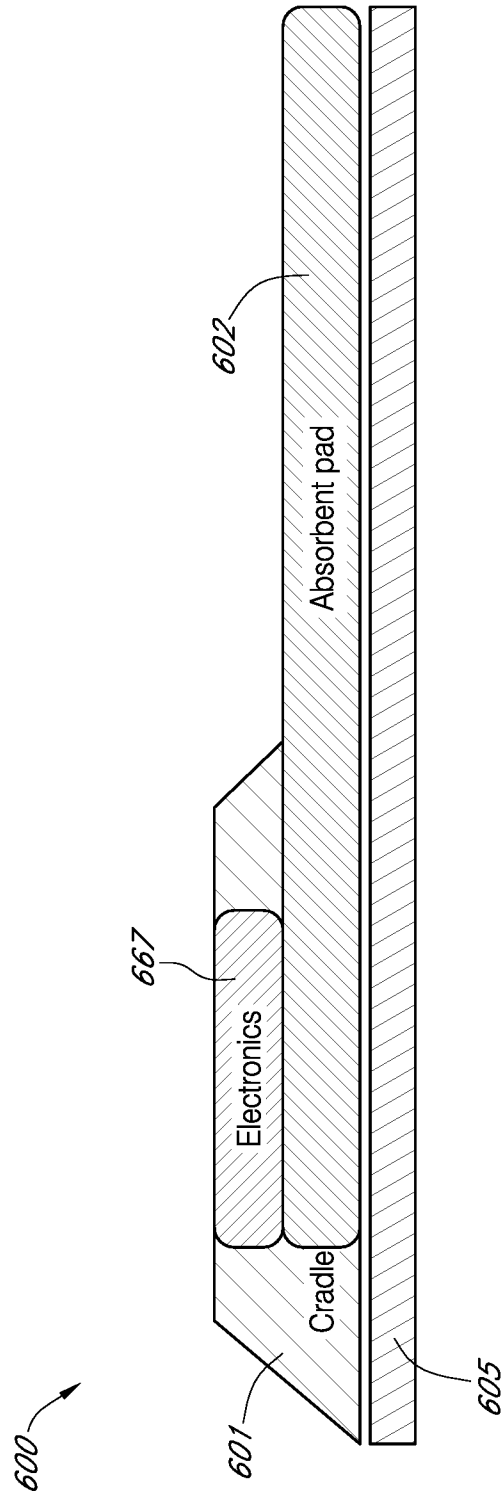

FIG. 20B

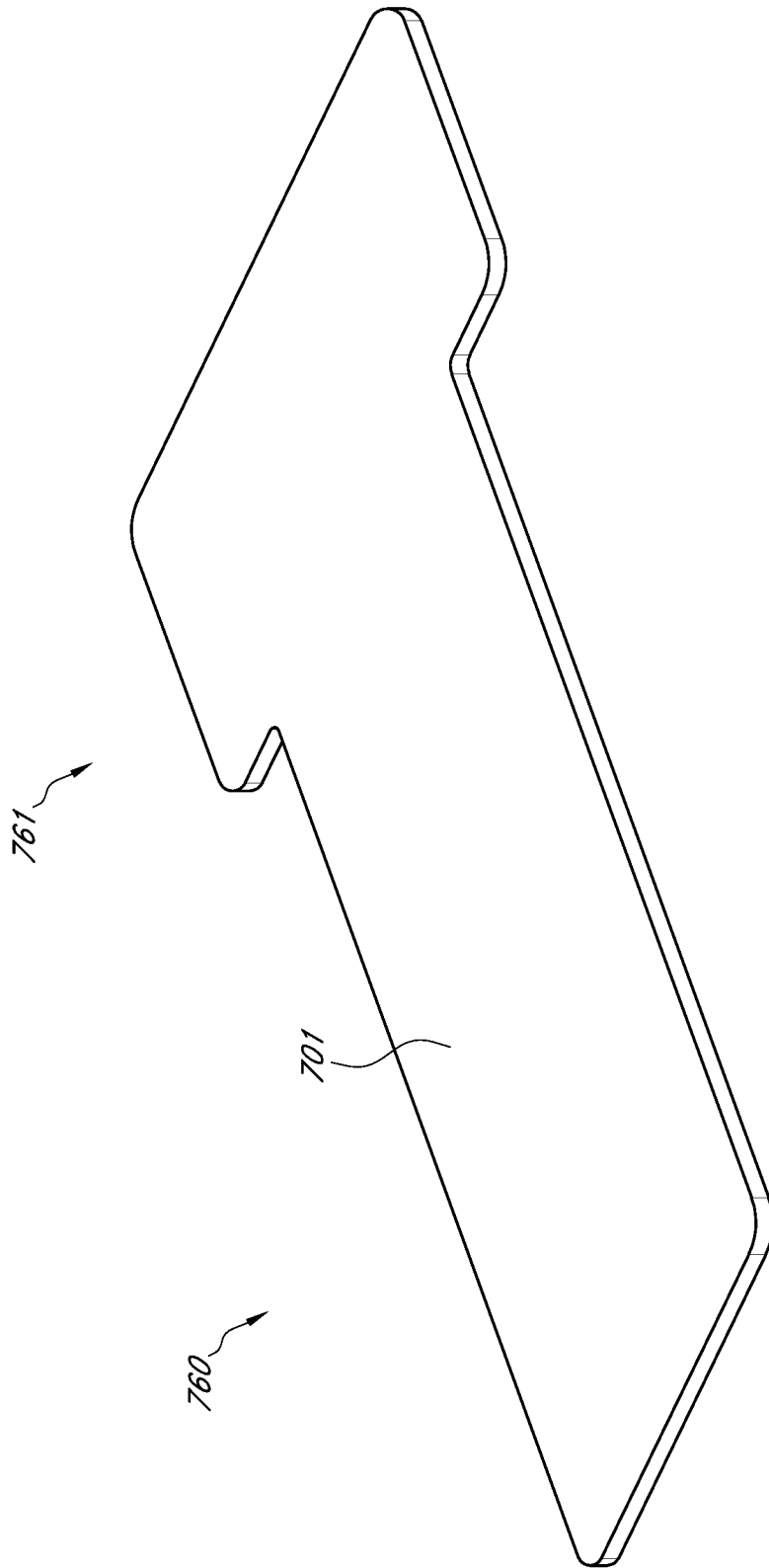

FIG. 21A

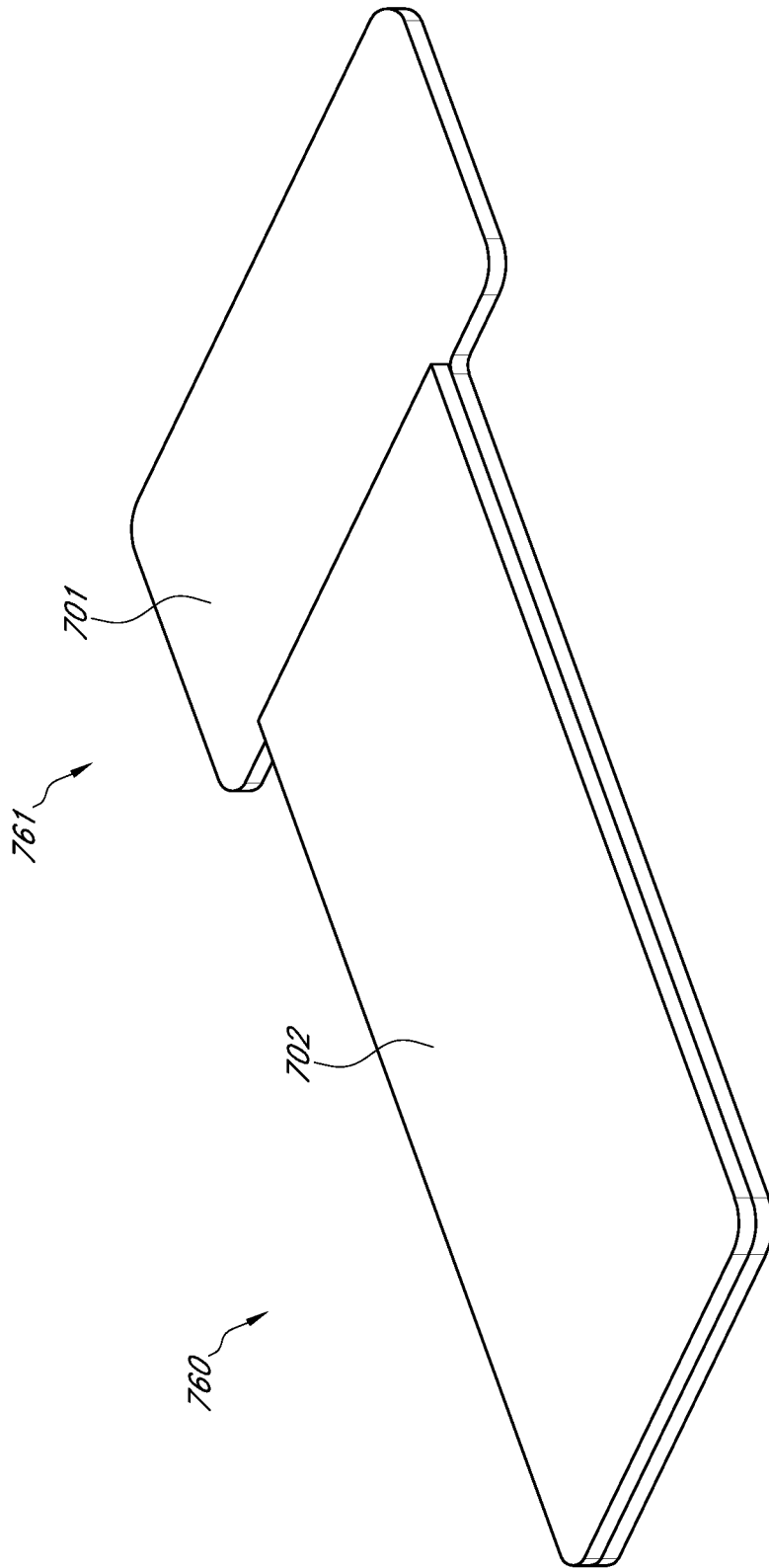

FIG. 21B

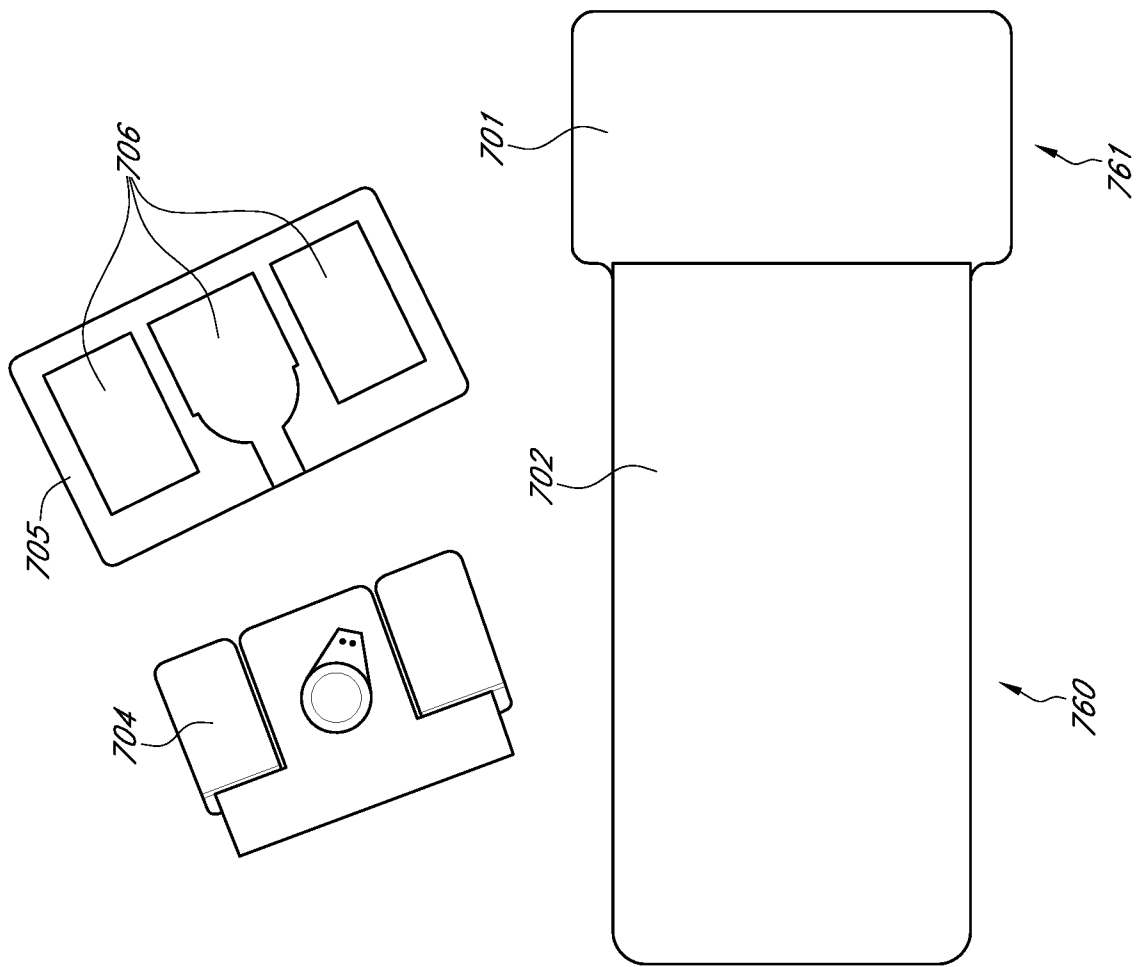

FIG. 21C

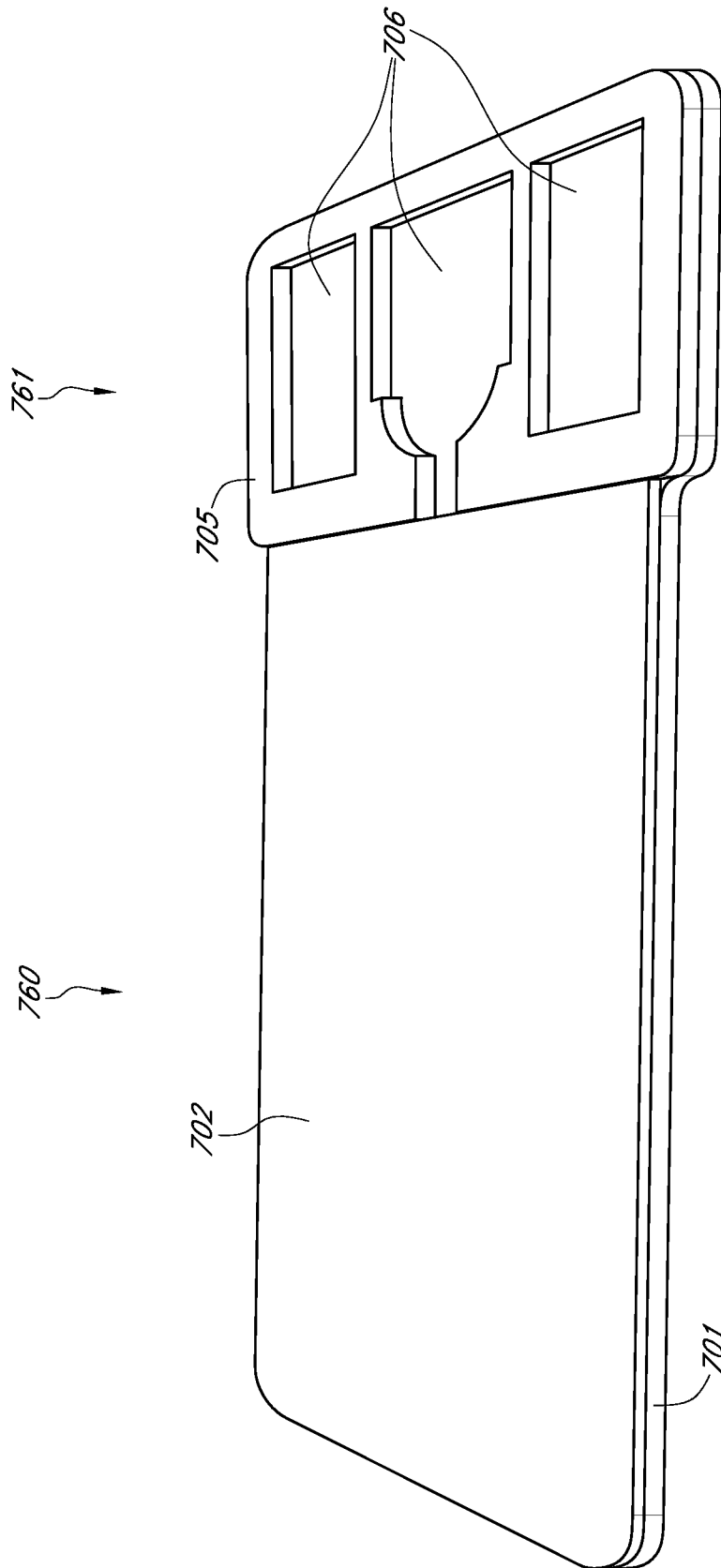

FIG. 21D

45/54

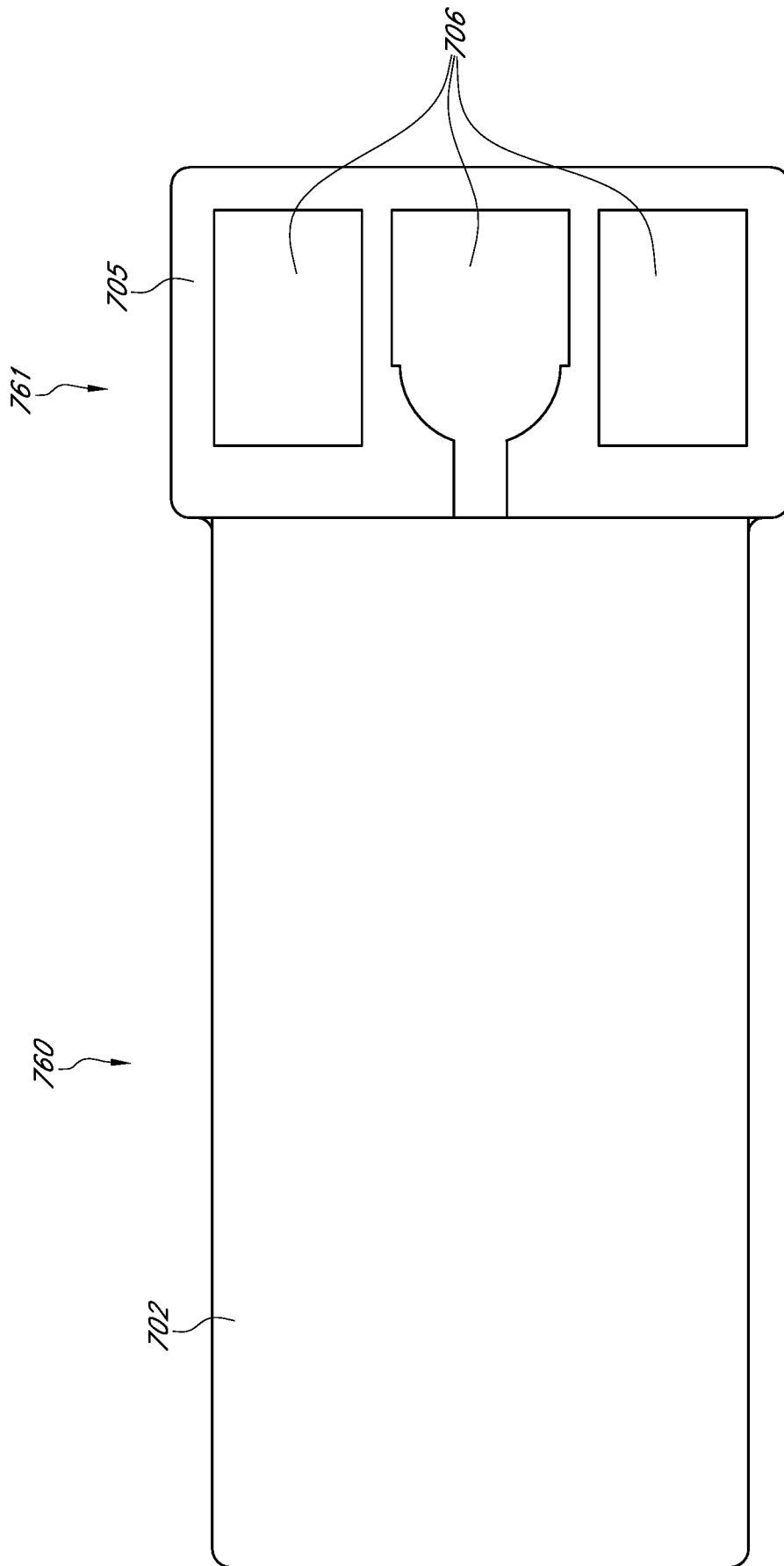

FIG. 21E

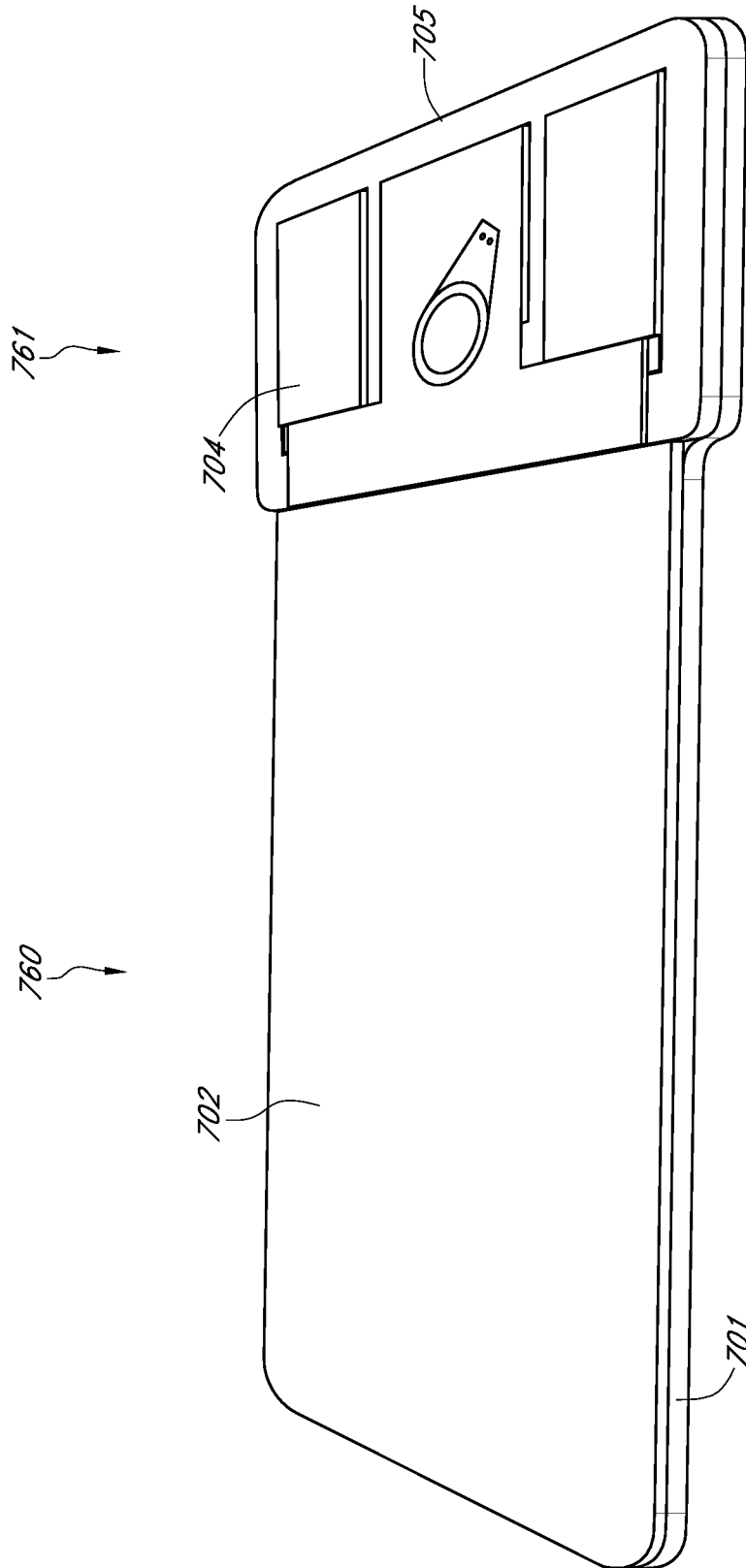

FIG. 21F

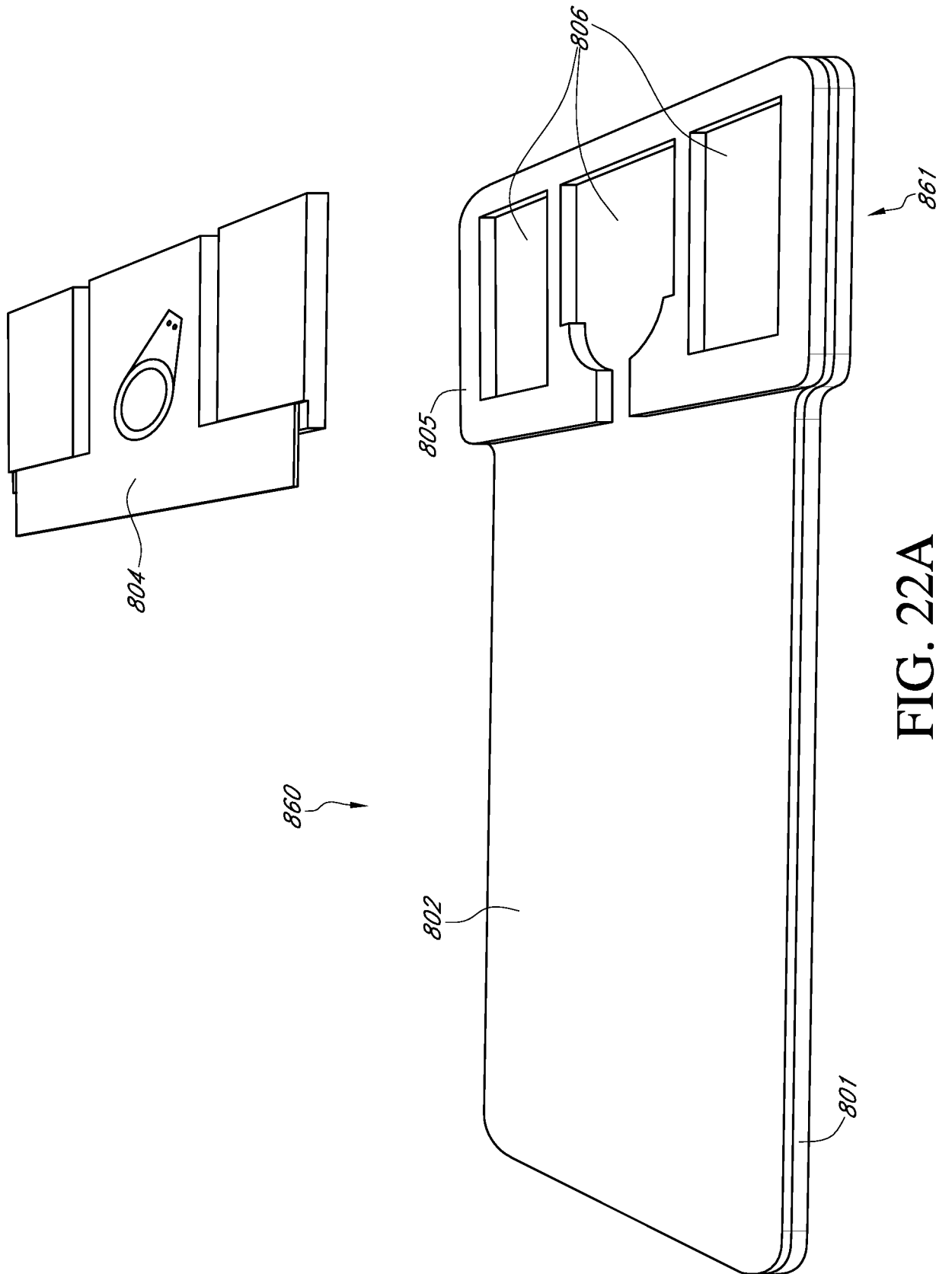

FIG. 22A

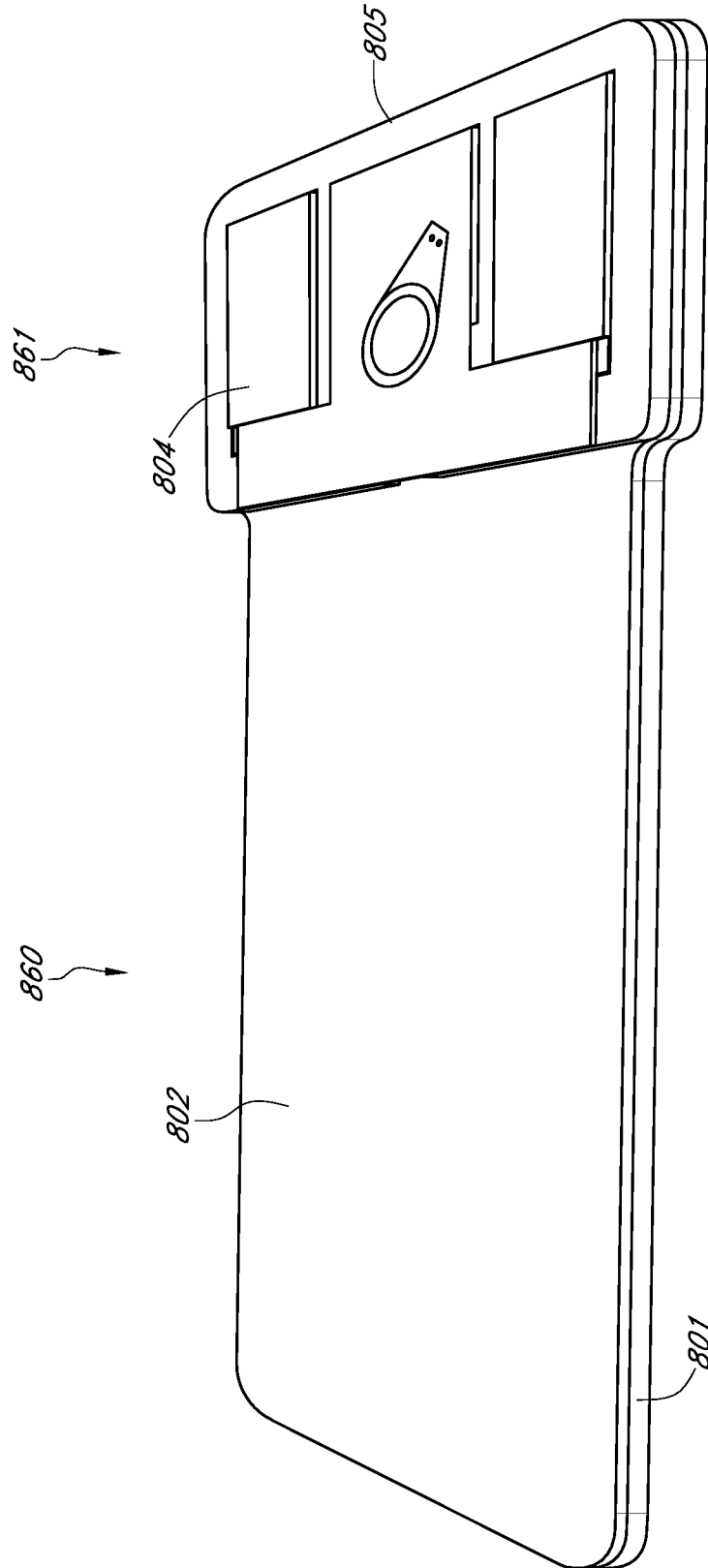

FIG. 22B

49/54

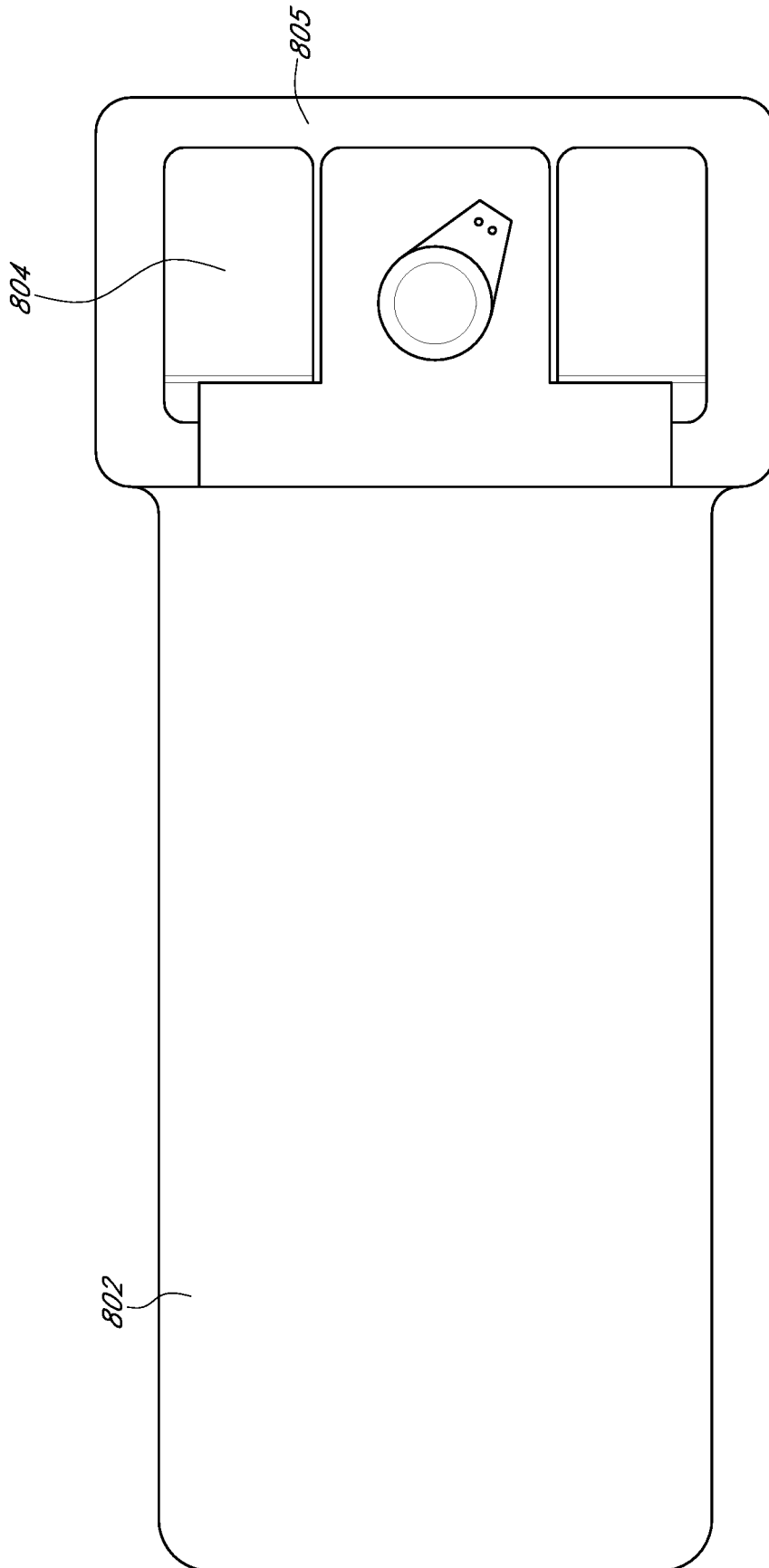

FIG. 22C

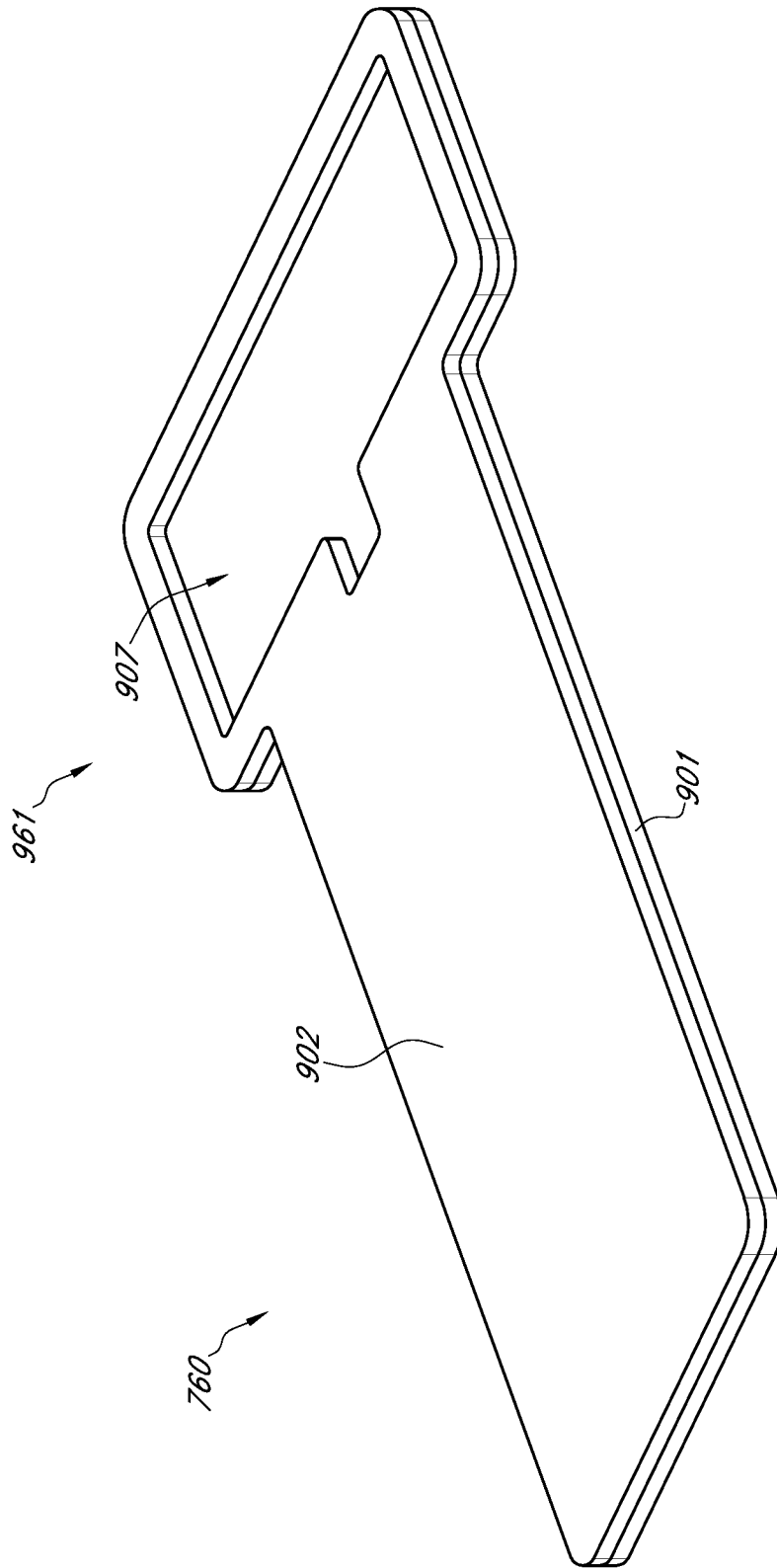

FIG. 23

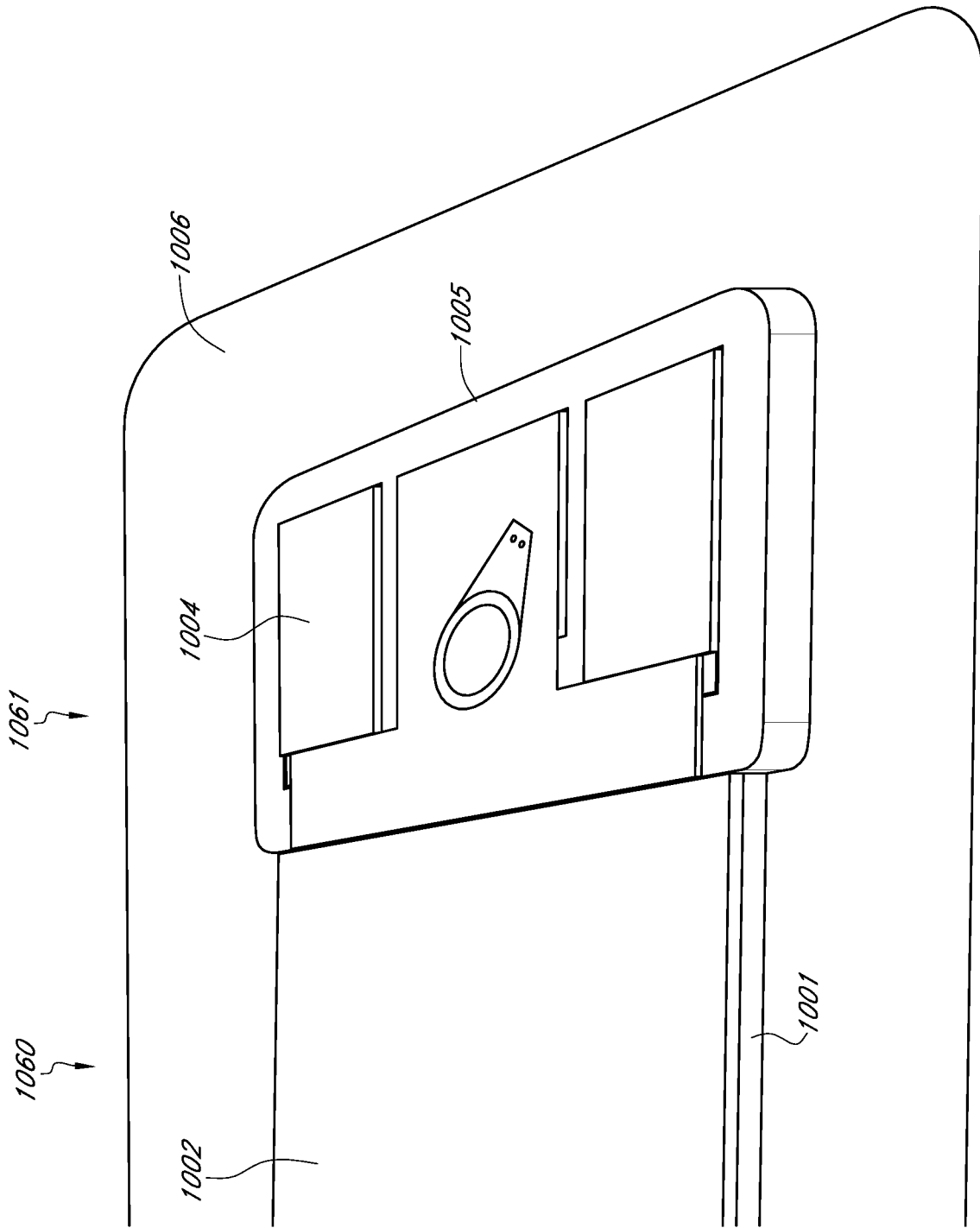

FIG. 24

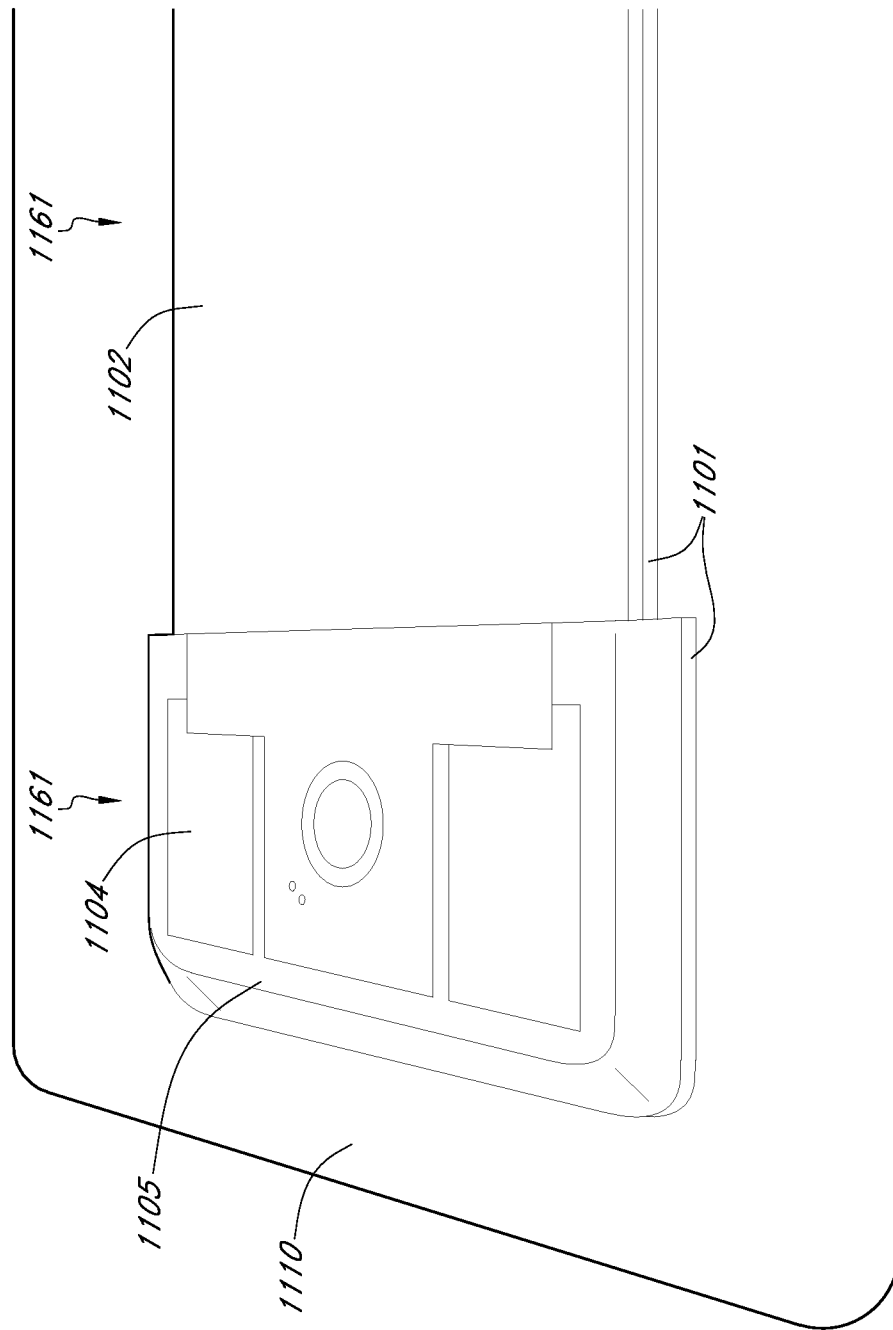

FIG. 25A

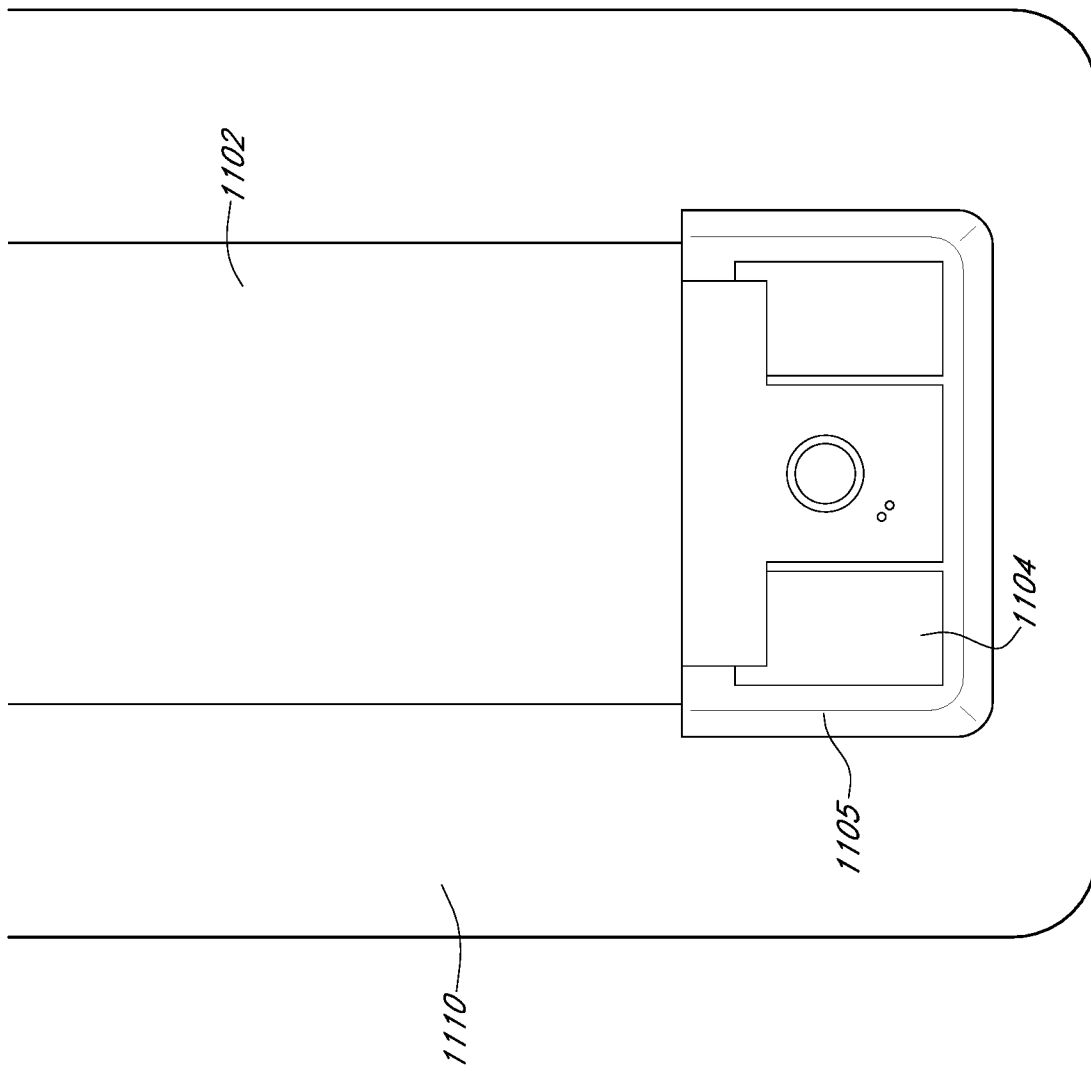

FIG. 25B

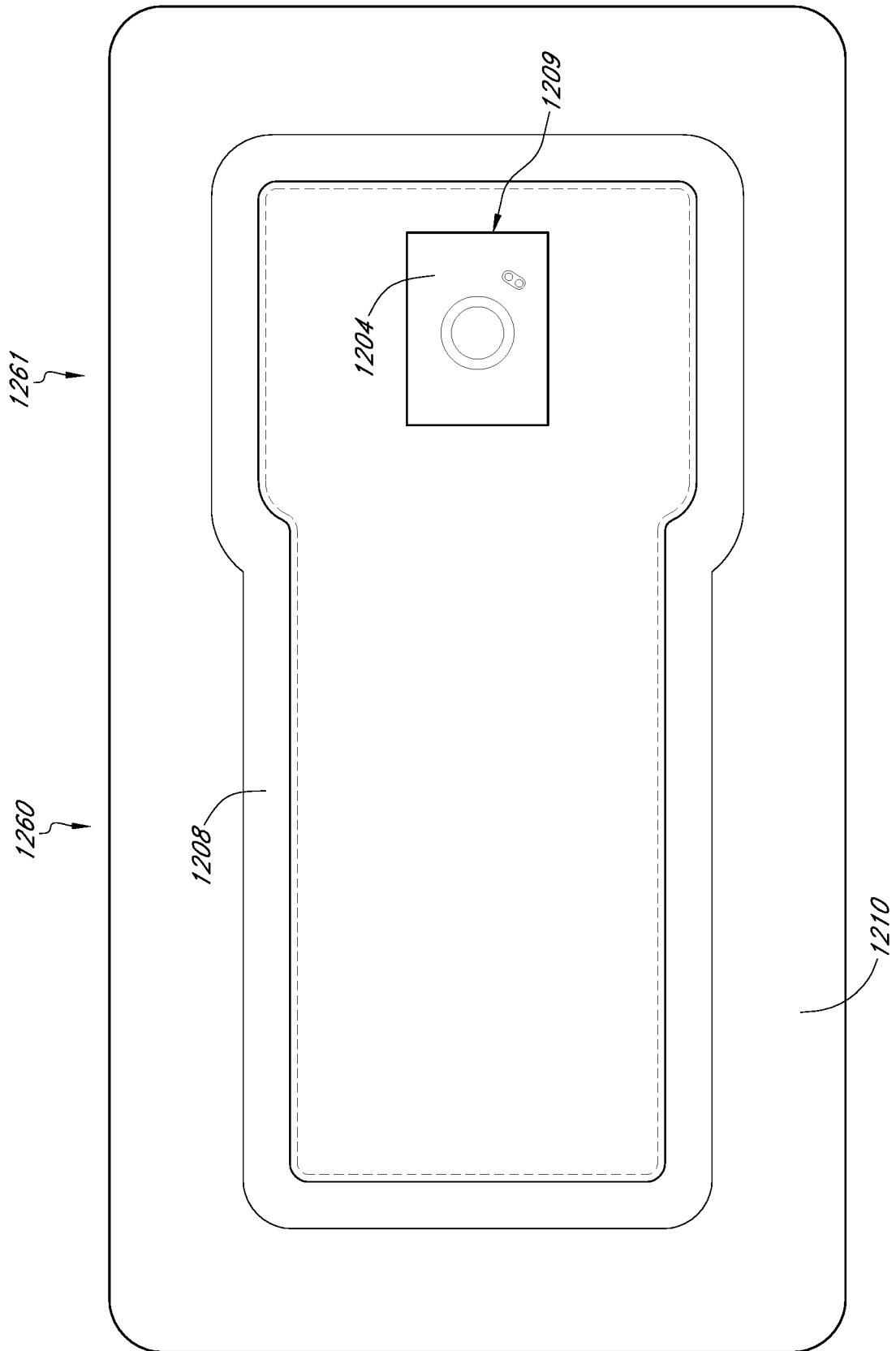

FIG. 26