

(No Model.)

2 Sheets—Sheet 1.

C. E. BAILEY & G. F. BOWEN.
METHOD OF AND DIE FOR THE MANUFACTURE OF BAND FORGINGS
FOR MILITARY RIFLES.

No. 526,286.

Fig. 1.

Patented Sept. 18, 1894.

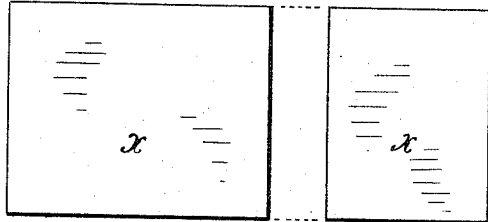

Fig. 2.

Fig. 3.

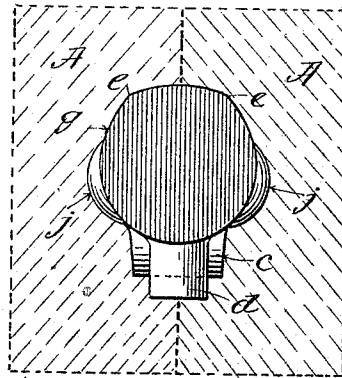
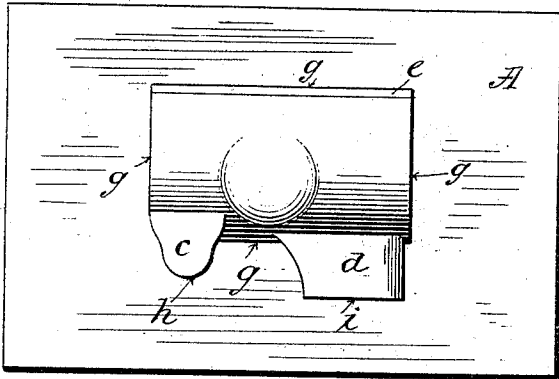

Fig. 4.

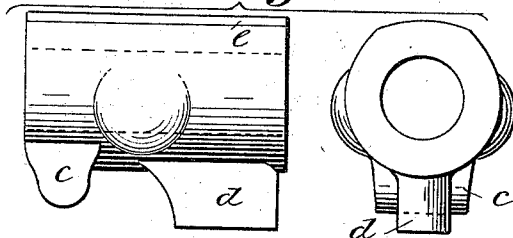

Fig. 5.

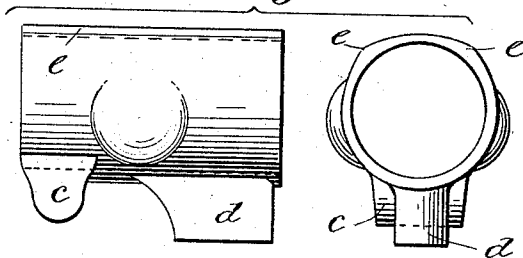
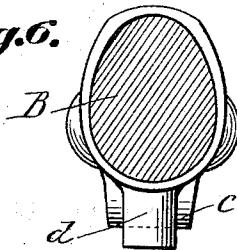

Fig. 6.



Witnesses:

J. W. Gifford,
H. J. Clemons

Inventors,

Chas. E. Bailey,
Geo. F. Bowen,
by Chapman
Attors

(No Model.)

2 Sheets—Sheet 2.

C. E. BAILEY & G. F. BOWEN.
METHOD OF AND DIE FOR THE MANUFACTURE OF BAND FORGINGS
FOR MILITARY RIFLES.

No. 526,286.

8 Fig. 7. Patented Sept. 18, 1894.

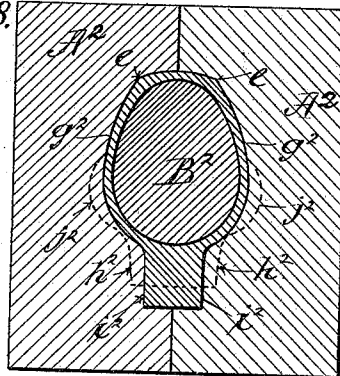
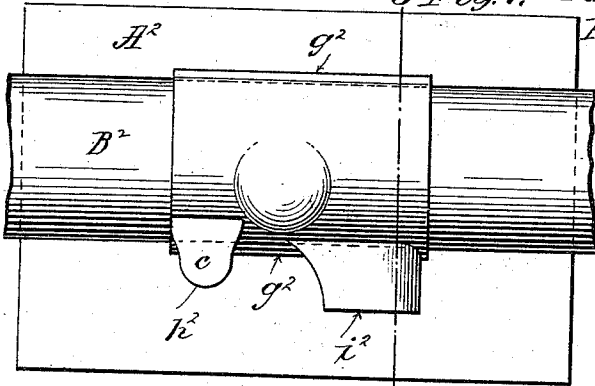

Fig. 8.

Fig. 9.

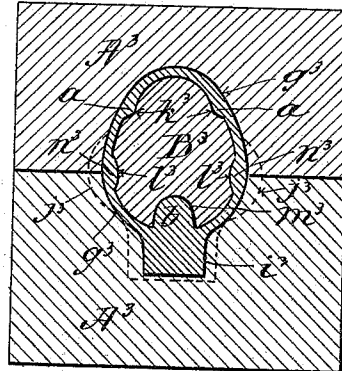
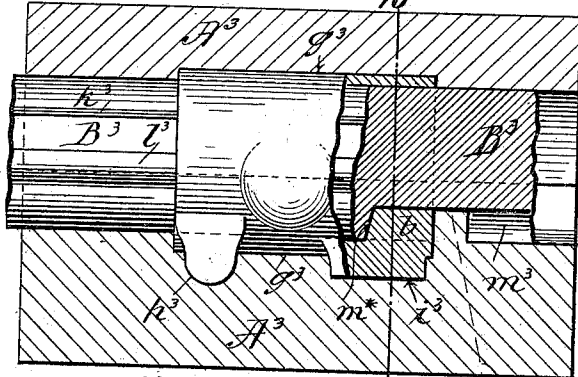

Fig. 10.

Fig. 11.

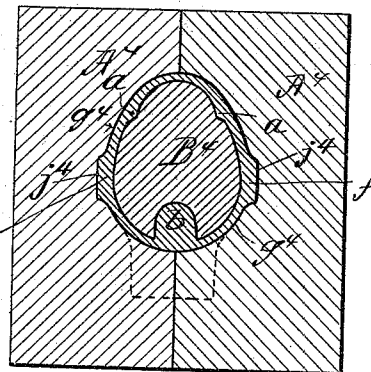
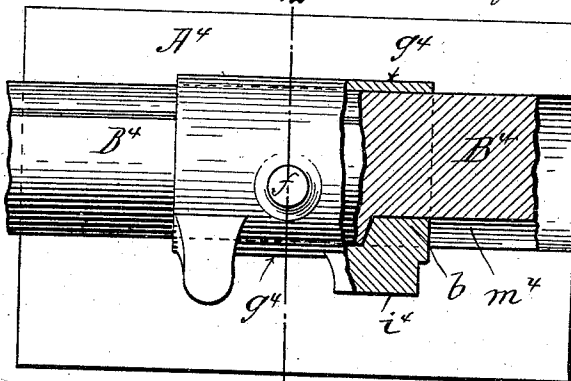

Fig. 12.

Fig. 13.

Witnesses:

J. R. Garfield
H. S. Clemens

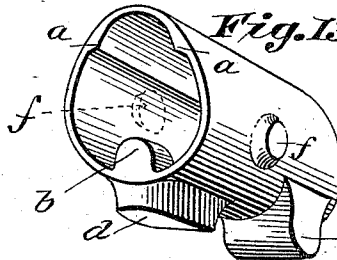

Fig. 13.

Inventors,
Chas. E. Bailey
Geo. F. Bowen
by Chapman & Co.
Attys.

UNITED STATES PATENT OFFICE.

CHARLES E. BAILEY AND GEORGE F. BOWEN, OF SPRINGFIELD, MASSACHUSETTS.

METHOD OF AND DIES FOR THE MANUFACTURE OF BAND-FORGINGS FOR MILITARY RIFLES.

SPECIFICATION forming part of Letters Patent No. 526,286, dated September 18, 1894.

Application filed March 9, 1894. Serial No. 502,982. (No model.)

To all whom it may concern:

Be it known that we, CHARLES E. BAILEY and GEORGE F. BOWEN, citizens of the United States, residing at Springfield, in the county of Hampden and State of Massachusetts, have invented new and useful Improvements in Methods of and Dies for the Manufacture of Band-Forgings for Military Rifles, of which the following is a specification.

This invention relates to the production, from an ingot, of a blank, or forging, which is in the form of a band and which has certain peculiar external and internal projections, or protuberances, the band blank being ultimately finished up to constitute a part of a well known form of military rifle, as will hereinafter somewhat more definitely be set forth.

The problem to be solved by the present invention is to devise a method of and means for producing, largely by forging operations, a band blank which has a given form and peculiarities.

The invention, as consisting in the production of the band forging is hereinafter fully described and set forth in the claims.

Reference is to be had to the accompanying drawings, in which—

Figure 1 is a side view of the ingot from which the band blank is to be produced, together with an end projection of the same. Fig. 2 is a side, or face view of one of the duplicated parts of a set of dies for the first drop, the resultant forged blank being seen.

Fig. 3 is an end view of the same forging, the pair of dies being indicated in dotted lines. Figs. 4 and 5 are side views, each with end projections, showing the next operations of boring to have been performed. Fig. 6 is an end view of the band indicating a modification in its cross-sectional form as produced by the contained mandrel. Fig. 7 is a view of the band and mandrel as last mentioned, in one of the duplicated die members which

are next used for acting on the forging. Fig. 8 is a cross section on line 8—8, Fig. 7. Fig. 9 is a longitudinal, and Fig. 10 a cross sectional view of the set of dies and peculiar mandrel next used, the forging as of the modification of its form as next produced thereby, being indicated. The line 10—10 in Fig. 9 indicates the plane on which the section, Fig. 10, is taken. Fig. 11 is a longitudinal, and

Fig. 12 a cross, section particularly showing the set of dies next used for effecting the final external formation of the forged blank, Fig. 13 being a perspective view of the latter.

The band forging, the production of which is within the province of this invention, and which is clearly shown in Fig. 13, consists of a band, or ring, of substantially oval cross section having the internal, longitudinally extended, thickened portions, *a, a*, the internal stud, *b*, (designed to be further worked out to adapt it for supporting the ram-rod,) the external swivel-boss, *c*, the external bayonet holding stud, *d*, and the lateral, external, opposed screw bosses, *f, f*. The ingots, *x*, from which the band forging is produced, as shown, are uniform, rectangular blocks of just the proper size so that in forging there is no endwise displacement, and little waste in the longitudinal fins at top and bottom of the band. The red hot ingot, at the first drop, is between the dies, *A, A*, Figs. 2 and 3, each member of which has the depression, *g*, of a general hemi-cylindrical form, each terminating within the ends of the die blocks, and it is provided with the depressions, *h* and *i*, within its face, each of which matches with its fellow, the two of each of which form the die openings for said swivel boss, *c*, and bayonet-holding stud, *d*, while in the base of the depression, *g*, of each die is the further rounded depression, *j*, for bringing out a protuberance on the forging for each lateral swell or boss, *f*. The cross section of the die chamber, formed by the said depressions, *g*, *g*, while generally, or approximately, circular, is enlarged, radially, at *e* and *e*, to impart a little extra stock, externally, at each side of the crest of the forging, which enlargements are ultimately utilized to form the internal ridges, *a, a*. The body of the forging, which has a diameter, say of one inch, is next axially drilled with a five-eighths inch hole, as seen in Fig. 4; and again drilled to enlarge the hole to seven-eighths of an inch, bringing the forging to the band form shown in Fig. 5. A mandrel, *B*, of oval cross section, is driven into the forging bringing it to the cross sectional form seen in Fig. 6. This mandrel may, at one extremity, be tapered so that it merges from a circular form, to readily enter the seven-eighths of an inch hole, up to the oval form shown by Fig. 6. The band and

this mandrel (or another similar one, either of which has a uniform diameter throughout a portion as long as the band) are placed in the dies A^2, A^2 , seen in Figs. 7 and 8, for bringing the band straight and even. In these dies are openings leading from the main die chambers, g, g , to the ends for the accommodation of the mandrel, as shown, and they also have the depressions, h^2, i^2, j^2 , leading from the main die chambers, g^2 , for the accommodation of the stock for the stud, d , and bosses, c and f, f . A pair of dies, A^3, A^3 , and a mandrel, B^3 , of further modified shape are used for producing the internal ribs, a, a , and the internal bayonet holding stud, b . The said dies, A^3, A^3 , have the main chamber, g , of a perfectly oval cross sectional form, with the further depressions, h^3, i^3, j^3 , for the aforesaid external bosses, the depression, v^3 , however, being of less depth than the corresponding depressions, i or i^2 , in the preceding dies. Here the die chambers open endwise for the accommodation of the mandrel. The mandrel, B^3 , now used is longitudinally grooved, as at l^3, l^3 , next within the thickened parts, e, e , of the forging. The mandrel also has the longitudinal side grooves, l^3, l^3 , and also the longitudinal bottom groove, m^3 , which, unlike the other grooves, has the end wall, m^3 , standing at almost a right angle to its length, at an intermediate part thereof; and when the mandrel is in the dies, as seen in said Fig. 9, the said end wall of the groove is at a short distance from the forward end of the band forging. This pair of dies, unlike all of the other dies employed, instead of having their separating faces corresponding to the long, or vertical, diameter of the oval band, separate on the short diameter thereof, and the lower die has the stud, g , to project up into the mandrel groove at a short distance from the end wall, m^3 , to prevent, at this part of the forging operation the endwise displacement of the metal forming the internal stud, b . The result of the forging action upon the partially forged band, using these dies in combination with the mandrel, grooved, as stated, is, firstly, to force a part of the metal which is at, or next to, the base of the stud, d , to produce the stud, b , which inwardly extends within the internal periphery of the band, as shown in Fig. 13; secondly, to force the outwardly and longitudinally thickened metal parts, e, e , into the longitudinal grooves of the mandrel to produce the internal longitudinal ribs, or shoulders, a, a ; and, thirdly, to provide temporary opposing reinforcing ribs, n^3, n^3 , so as to enable the band to withstand this forging operation without cracking or breaking along the sides. The forging band is next placed within the last pair of dies, A^4, A^4 , Figs. 11 and 12, which are precisely like those, A^3, A^3 , next previously employed, with the exception that they separate sidewise, as to the dies, A and A^2 , and that the superficially large, rounded depressions give place to depressions, j^4, j^4 , which have plane bases and flar-

ing circular mouths, for the production, under the next forging operation, of the trunion-like screw bosses, f, f , having flat, outer surfaces and concave flanks, as seen in Figs. 12, 13, and 14. The mandrel, B^4 , used in combination with these dies is like the one, B^3 , previously employed, minus the side grooves, n^3, n^3 . Now this mandrel, which may be tapered, may be introduced by being forcibly driven into the band of the form seen in Fig. 10, swaging out the aforementioned internal reinforcing thickened parts, l^3, l^3 , or the said ribs may be otherwise removed, or displaced, to leave the inner sides of the band smooth and even, as seen in Fig. 13.

Having thus described our invention, what we claim, and desire to secure by Letters Patent, is—

1. The method herein described of producing a band forging having externally and internally protruding studs, d and b , which consists in drop-forging an ingot to produce an approximately cylindrical piece having a radially extended projection, boring the forging to bring it to annular form, and again drop-forging the part to force a portion of the metal at the base of the external radial projection within the bore of the band, substantially as described.

2. The method herein described of producing an oval band forging having externally and internally protruding studs, d and b , which consists in drop-forging an ingot to produce a substantially cylindrical piece having a radially extended projection, boring the forging to bring it to annular form, elongating the band transversely, and again forging the part to force a portion of the metal at the base of the external, radial projection within the bore of the band, substantially as described.

3. The method herein described of producing an oval band forging having externally and internally protruding studs, d and b , and the internal longitudinal ribs, or shoulders, a, a , which consists in drop-forging an ingot to produce a substantially cylindrical piece having the longitudinally extending, externally thickened portions, and a radially extended external projection, boring the forging to bring it to annular form, elongating the band, transversely, and again forging the part to force a portion of the metal at the base of the external radial projection within the bore of the band, and displacing the metal at said externally thickened portions to produce said longitudinal ribs, a, a , substantially as described.

4. The method herein described of producing a band forging having externally and internally protruding studs, d and b , which consists in drop-forging an ingot to produce a substantially cylindrical piece, having a radially extended projection, boring the forging to bring it to annular form, striking up temporary reinforcing ribs along each side of the band and further forging the part to force

a portion of the metal at the base of the external radial projection within the bore of the band, thereby forming the internal stud, substantially as described.

5 5. The method herein described of producing a forging band with internal longitudinal ribs, which consists in die-forging an ingot to a general cylindrical form, with, however, external longitudinally enlarged portions, as *e, e*, boring the forging, axially, and by die-forging displacing the outwardly enlarged portions to produce the internally protruding ribs, substantially as and for the purposes set forth.

15 6. The combination with a pair of forging dies, A^3, A^3 , having a cylindrical, or oval, die chamber, with mandrel openings therefrom to the ends of the die, and having the further depression, v^3 , of the mandrel, B^3 , having the groove, m^3 , in its under side with an end wall which may be located next within said depression, v^3 , substantially as and for the purpose set forth.

25 7. A pair of forging dies, A^3, A^3 , having an oval die chamber with mandrel openings therefrom to the ends of the die, and having the further depression, v^3 , and the cooperating mandrel, B^3 , with the groove, m^3 , and end wall, m^* , as described in combination with a set of dies, A^2, A^2 , having a substantially oval die chamber and endwise openings and depression, v^2 , and the oval mandrel, B^2 , which is ungrooved along its side next to the depression, v^2 , substantially as described.

35 8. A pair of forging dies, A, A , with substantially cylindrical and endwise closed die-chambers with the further depression, i , in combination with a second set of dies, A^2, A^2 , with a die chamber which has an approximately oval transverse contour and endwise mandrel openings, and the depression, v^2 , and oval mandrel, B^2 , together with the set of dies, A^3, A^3 , having a similarly oval die chamber, endwise mandrel openings and depression, v^3 , and the coating mandrel provided with the groove, m^3 , in its under side with the end wall, m^* , which terminates next within said depression, m^3 , substantially as described.

50 9. A pair of forging dies, A, A , with substantially cylindrical and endwise closed die-chamber with the enlargements, *e, e*, and the further depression, i , in combination with a second set of dies, A^2, A^2 , with a die chamber which has an approximately oval transverse contour and endwise mandrel openings, and the depression, v^2 , and oval mandrel, B^2 , together with the set of dies, A^3, A^3 , having a truly oval die chamber, endwise mandrel openings and depression, v^3 , and the coating mandrel provided with the groove, m^3 , in its under side with the end wall, m^* , which terminates next within said depression, m^3 , and having the longitudinal grooves, k^3, k^3 , substantially as described.

65 10. A pair of forging dies, A^2, A^2 , with a substantially cylindrical die chamber having the

enlargements, *e, e*, and depression, v^2 , in combination with an oval mandrel, B^2 , and the pair of dies, A^3, A^3 , with the oval die chamber with endwise mandrel openings, and the depression, v^3 , together with the mandrel, B^3 , provided with longitudinal bottom groove, m^3 , having end wall, m^* , and longitudinal grooves, k^3, k^3 , substantially as and for the purpose set forth.

70 11. The combination with a pair of forging dies, A^3, A^3 , having an oval die chamber with endwise mandrel openings and having the further depressions, v^3 , of the mandrel having the groove, m^3 , with end wall, m^* , and side grooves, l^3, l^3 , substantially as and for the purposes set forth.

75 12. The combination with a pair of forging dies, A^3, A^3 , having an oval die chamber and the depression, v^3 , of the oval mandrel having the under side groove, m^3 , with the end wall, m^* , the sidewise, longitudinal grooves, l^3, l^3 , and the longitudinal grooves, k^3, k^3 , at each side of the top of the mandrel, substantially as described.

80 13. A pair of forging dies having a die chamber which is approximately cylindrical for the body of the forging and which has further depression at its bottom for the production of a longitudinally extending stud at the base of the forging and another die depression at the base of the die chamber at a different place in its length for the production of a transversely extending stud, or boss, on the under side of the body of the forging, substantially as described.

85 14. A pair of forging dies having a cylindrical, or oval die chamber with the two further base depressions, of the mandrel having the groove, m^3 , with end wall, m^* , substantially as described.

90 15. The combination with a pair of forging dies, A^3, A^3 , with oval die chamber having the sidewise concave depressions, j^3, j^3 , of the forging dies, A^4, A^4 , with a similarly oval die chamber having the sidewise depressions which have flat bases and their openings leading to the main die chamber flaring substantially as shown.

95 16. The combination with a pair of forging dies having the cylindrical, or oval, die chamber with the base depression, v^3 , and the inwardly projecting stud, q , next thereto, of the mandrel having the groove, m^3 , and provided with end wall, m^* , substantially as described.

100 17. A pair of dies having a main die chamber of a modified cylindrical form and having the sidewise depressions and two base depressions, in combination with a mandrel having the longitudinal groove which terminates in one end wall intermediate between its ends, substantially as described.

CHARLES E. BAILEY.
GEORGE F. BOWEN.

Witnesses:

WM. S. BELLOWS,
K. I. CLEMONS.