

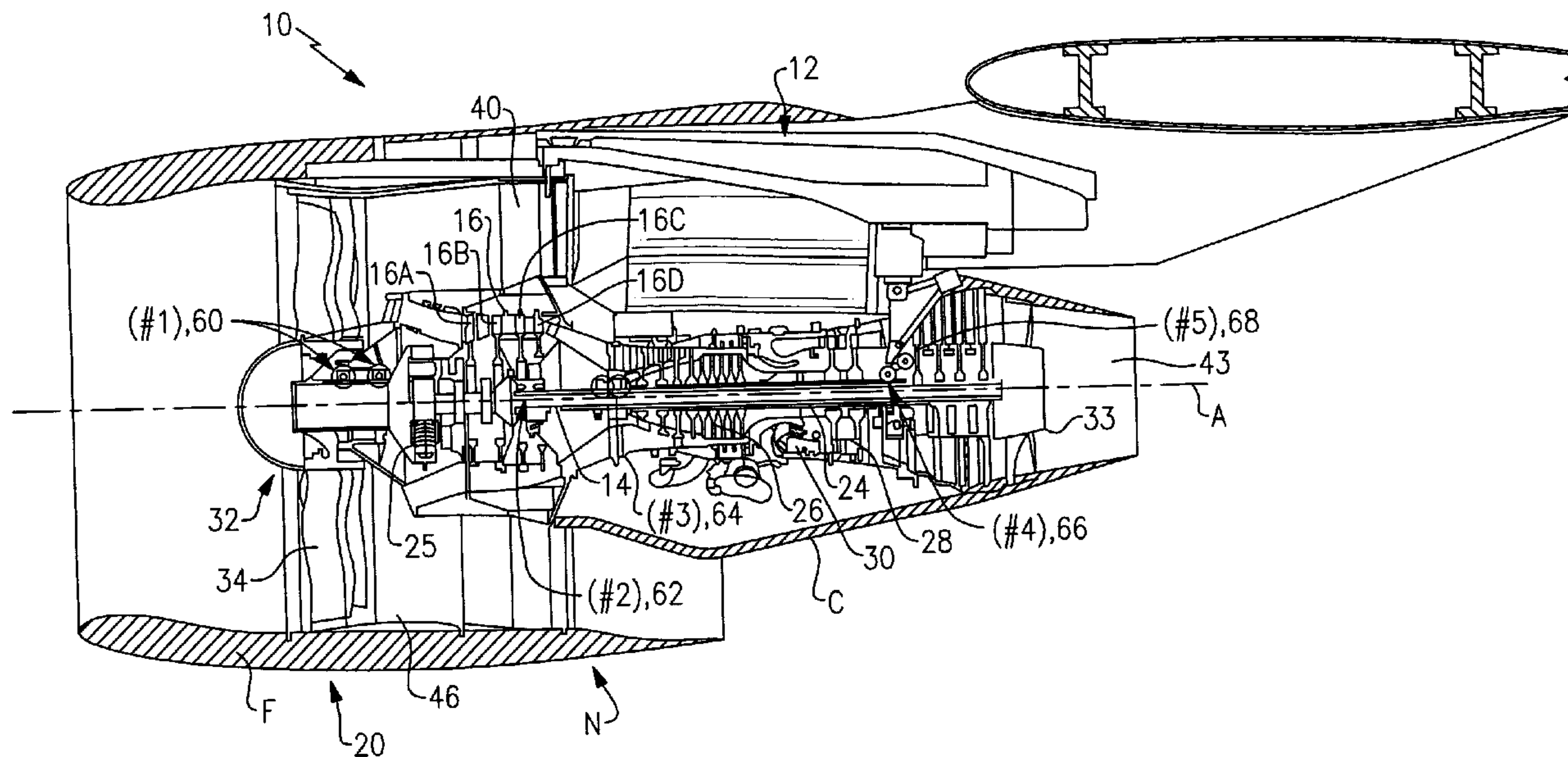

(22) Date de dépôt/Filing Date: 2012/12/21
(41) Mise à la disp. pub./Open to Public Insp.: 2013/06/30
(30) Priorité/Priority: 2011/12/30 (US13/340,988)

(51) Cl.Int./Int.Cl. *F02C 9/18* (2006.01),
F01D 25/28 (2006.01), *F02C 7/36* (2006.01),
F02K 1/06 (2006.01), *F02K 1/15* (2006.01)
(71) Demandeur/Applicant:
UNITED TECHNOLOGIES CORPORATION, US
(72) Inventeurs/Inventors:
SUCIU, GABRIEL L., US;
MERRY, BRIAN D., US;
DYE, CHRISTOPHER M., US;
JOHNSON, STEVEN B., US;
SCHWARZ, FREDERICK M., US
(74) Agent: NORTON ROSE FULBRIGHT CANADA
LLP/S.E.N.C.R.L., S.R.L.

(54) Titre : TURBINE A GAZ AVEC TURBINE A FAIBLE NOMBRE D'ETAGES ET FAIBLE PRESSION
(54) Title: GAS TURBINE ENGINE WITH LOW STAGE COUNT LOW PRESSURE TURBINE



(57) Abrégé/Abstract:
A gas turbine engine includes a spool along an engine centerline axis which drives a gear train.



ABSTRACT

A gas turbine engine includes a spool along an engine centerline axis which drives a gear train.

GAS TURBINE ENGINE WITH LOW STAGE COUNT LOW PRESSURE TURBINE

5 **BACKGROUND**

The present invention relates to a gas turbine engine and more particularly to an engine mounting configuration for the mounting of a turbofan gas turbine engine to an aircraft pylon.

10 A gas turbine engine may be mounted at various points on an aircraft such as a pylon integrated with an aircraft structure. An engine mounting configuration ensures the transmission of loads between the engine and the aircraft structure. The loads typically include the weight of the engine, thrust, aerodynamic side loads, and rotary torque about the engine axis. The engine mount configuration must also absorb the deformations to which the engine is subjected during different flight
15 phases and the dimensional variations due to thermal expansion and retraction.

One conventional engine mounting configuration includes a pylon having a forward mount and an aft mount with relatively long thrust links which extend forward from the aft mount to the engine intermediate case structure. Although effective, one disadvantage of this conventional type mounting arrangement is the
20 relatively large "punch loads" into the engine cases from the thrust links which react the thrust from the engine and couple the thrust to the pylon. These loads tend to distort the intermediate case and the low pressure compressor (LPC) cases. The distortion may cause the clearances between the static cases and rotating blade tips to increase which may negatively affect engine performance and increase fuel burn.

25

SUMMARY

A gas turbine engine according to an exemplary aspect of the present disclosure includes a core nacelle defined about an engine centerline axis, a fan nacelle mounted at least partially around the core nacelle to define a fan bypass
30 airflow path for a fan bypass airflow, a gear train defined along an engine centerline axis, the gear train defines a gear reduction ratio of greater than or equal to about 2.3, a spool along the engine centerline axis which drives the gear train, the spool

includes a three to six (3-6) low pressure turbine, and a fan variable area nozzle axially movable relative to the fan nacelle to vary a fan nozzle exit area and adjust a pressure ratio of the fan bypass airflow during engine operation.

5 In a further non-limiting embodiment of any of the foregoing gas turbine engine embodiments, the spool may be a low spool.

In a further non-limiting embodiment of any of the foregoing gas turbine engine embodiments, the low pressure turbine may define a pressure ratio that is greater than about five (5). Additionally or alternatively, the low pressure turbine may define a pressure ratio that is greater than five (5).

10 In a further non-limiting embodiment of any of the foregoing gas turbine engine embodiments, the bypass flow may define a bypass ratio greater than about ten (10). Additionally or alternatively, the bypass flow may define a bypass ratio greater than ten (10).

15 In a further non-limiting embodiment of any of the foregoing gas turbine engine embodiments, the gear train may define a gear reduction ratio of greater than or equal to about 2.5. Additionally or alternatively, the gear train may define a gear reduction ratio of greater than or equal to 2.5.

20 In a further non-limiting embodiment of any of the foregoing gas turbine engine embodiments, the engine may further include a controller operable to control the fan variable area nozzle to vary the fan nozzle exit area and adjust the pressure ratio of the fan bypass airflow.

25 In a further non-limiting embodiment of any of the foregoing gas turbine engine embodiments, the controller may be operable to reduce the fan nozzle exit area at a cruise flight condition. Additionally or alternatively, the controller may be operable to control the fan nozzle exit area to reduce a fan instability.

In a further non-limiting embodiment of any of the foregoing gas turbine engine embodiments, the fan variable area nozzle may define a trailing edge of the fan nacelle.

30 In a further non-limiting embodiment of any of the foregoing gas turbine engine embodiments, the gear train may drive a fan within the fan nacelle.

A gas turbine engine according to another exemplary aspect of the present disclosure includes a gear train defined along an engine centerline axis, the gear train defines a gear reduction ratio of greater than or equal to about 2.3, and a spool along

the engine centerline axis which drives the gear train, the spool includes a three to six (3-6) low pressure turbine.

In a further non-limiting embodiment of any of the foregoing gas turbine engine embodiments, the low pressure turbine may be a three (3) stage low pressure turbine. Additionally or alternatively, the low pressure turbine may be a five (5) or six (6) stage low pressure turbine.

In a further non-limiting embodiment of any of the foregoing gas turbine engine embodiments, the low pressure turbine may define a pressure ratio that is greater than about five (5). Additionally or alternatively, the bypass flow may define a bypass ratio greater than about ten (10).

In a further non-limiting embodiment of any of the foregoing gas turbine engine embodiments, the gear train may define a gear reduction ratio of greater than or equal to about 2.5.

In a further non-limiting embodiment of any of the foregoing gas turbine engine embodiments, the low pressure turbine may defines a pressure ratio that is greater than five (5), the bypass flow defines a bypass ratio greater than ten (10), and the gear train defines a gear reduction ratio of greater than or equal to 2.5.

BRIEF DESCRIPTION OF THE DRAWINGS

The various features and advantages of this invention will become apparent to those skilled in the art from the following detailed description of the currently disclosed embodiment. The drawings that accompany the detailed description can be briefly described as follows:

Figure 1A is a general schematic sectional view through a gas turbine engine along the engine longitudinal axis;

Figure 1B is a general sectional view through a gas turbine engine along the engine longitudinal axis illustrating an engine static structure case arrangement on the lower half thereof;

Figure 1C is a side view of an mount system illustrating a rear mount attached through an engine thrust case to a mid-turbine frame between a first and second bearing supported thereby;

Figure 1D is a forward perspective view of an mount system illustrating a rear mount attached through an engine thrust case to a mid-turbine frame between a first and second bearing supported thereby;

Figure 2A is a top view of an engine mount system;

5 Figure 2B is a side view of an engine mount system within a nacelle system;

Figure 2C is a forward perspective view of an engine mount system within a nacelle system;

Figure 3 is a side view of an engine mount system within another front mount;

10 Figure 4A is an aft perspective view of an aft mount;

Figure 4B is an aft view of an aft mount of Figure 4A;

Figure 4C is a front view of the aft mount of Figure 4A;

Figure 4D is a side view of the aft mount of Figure 4A;

Figure 4E is a top view of the aft mount of Figure 4A;

15 Figure 5A is a side view of the aft mount of Figure 4A in a first slide position; and

Figure 5B is a side view of the aft mount of Figure 4A in a second slide position.

20 **DETAILED DESCRIPTION OF THE DISCLOSED EMBODIMENT**

Figure 1A illustrates a general partial fragmentary schematic view of a gas turbofan engine 10 suspended from an engine pylon 12 within an engine nacelle assembly N as is typical of an aircraft designed for subsonic operation.

25 The turbofan engine 10 includes a core engine within a core nacelle C that houses a low spool 14 and high spool 24. The low spool 14 includes a low pressure compressor 16 and low pressure turbine 18. The low spool 14 drives a fan section 20 connected to the low spool 14 either directly or through a gear train 25.

30 The high spool 24 includes a high pressure compressor 26 and high pressure turbine 28. A combustor 30 is arranged between the high pressure compressor 26 and high pressure turbine 28. The low and high spools 14, 24 rotate about an engine axis of rotation A.

The engine 10 in one non-limiting embodiment is a high-bypass geared architecture aircraft engine. In one disclosed, non-limiting embodiment, the engine

10 bypass ratio is greater than about six (6), with an example embodiment being greater than ten (10), the gear train 25 is an epicyclic gear train such as a planetary gear system or other gear system with a gear reduction ratio of greater than about 2.3 and the low pressure turbine 18 has a pressure ratio that is greater than about 5. In
5 one disclosed embodiment, the engine 10 bypass ratio is greater than about ten (10:1), the turbofan diameter is significantly larger than that of the low pressure compressor 16, and the low pressure turbine 18 has a pressure ratio that is greater than about 5:1. The gear train 25 may be an epicycle gear train such as a planetary gear system or other gear system with a gear reduction ratio of greater than about
10 2.5:1. It should be understood, however, that the above parameters are only exemplary of one embodiment of a geared architecture engine and that the present invention is applicable to other gas turbine engines including direct drive turbofans.

Airflow enters the fan nacelle F which at least partially surrounds the core nacelle C. The fan section 20 communicates airflow into the core nacelle C to the
15 low pressure compressor 16. Core airflow compressed by the low pressure compressor 16 and the high pressure compressor 26 is mixed with the fuel in the combustor 30 where is ignited, and burned. The resultant high pressure combustor products are expanded through the high pressure turbine 28 and low pressure turbine
18. The turbines 28, 18 are rotationally coupled to the compressors 26, 16
20 respectively to drive the compressors 26, 16 in response to the expansion of the combustor product. The low pressure turbine 18 also drives the fan section 20 through gear train 25. A core engine exhaust E exits the core nacelle C through a core nozzle 43 defined between the core nacelle C and a tail cone 33.

With reference to Figure 1B, the low pressure turbine 18 includes a low
25 number of stages, which, in the illustrated non-limiting embodiment, includes three turbine stages, 18A, 18B, 18C. The gear train 22 operationally effectuates the significantly reduced number of stages within the low pressure turbine 18. The three turbine stages, 18A, 18B, 18C facilitate a lightweight and operationally efficient engine architecture. It should be appreciated that a low number of stages
30 contemplates, for example, three to six stages. Low pressure turbine 18 pressure ratio is pressure measured prior to inlet of low pressure turbine 18 as related to the pressure at the outlet of the low pressure turbine 18 prior to exhaust nozzle.

Thrust is a function of density, velocity, and area. One or more of these parameters can be manipulated to vary the amount and direction of thrust provided by the bypass flow B. The Variable Area Fan Nozzle (“VAFN”) 42 operates to effectively vary the area of the fan nozzle exit area 44 to selectively adjust the pressure ratio of the bypass flow B in response to a controller C. Low pressure ratio turbofans are desirable for their high propulsive efficiency. However, low pressure ratio fans may be inherently susceptible to fan stability/flutter problems at low power and low flight speeds. The VAFN 42 allows the engine to change to a more favorable fan operating line at low power, avoiding the instability region, and still provide the relatively smaller nozzle area necessary to obtain a high-efficiency fan operating line at cruise.

A significant amount of thrust is provided by the bypass flow B due to the high bypass ratio. The fan section 20 of the engine 10 is designed for a particular flight condition -- typically cruise at about 0.8 Mach and about 35,000 feet. The flight condition of 0.8 Mach and 35,000 ft, with the engine at its best fuel consumption - also known as “bucket cruise Thrust Specific Fuel Consumption (“TSFC”)” - is the industry standard parameter of lbm of fuel being burned divided by lbf of thrust the engine produces at that minimum point. “Low fan pressure ratio” is the pressure ratio across the fan blade alone, without the Fan Exit Guide Vane (“FEGV”) system 36. The low fan pressure ratio as disclosed herein according to one non-limiting embodiment is less than about 1.45. “Low corrected fan tip speed” is the actual fan tip speed in ft/sec divided by an industry standard temperature correction of $[(T_{\text{ambient deg R}}) / 518.7]^{0.5}$. The “Low corrected fan tip speed” as disclosed herein according to one non-limiting embodiment is less than about 1150 ft / second.

As the fan blades within the fan section 20 are efficiently designed at a particular fixed stagger angle for an efficient cruise condition, the VAFN 42 is operated to effectively vary the fan nozzle exit area 44 to adjust fan bypass air flow such that the angle of attack or incidence on the fan blades is maintained close to the design incidence for efficient engine operation at other flight conditions, such as landing and takeoff to thus provide optimized engine operation over a range of flight conditions with respect to performance and other operational parameters such as noise levels.

The engine static structure 44 generally has sub-structures including a case structure often referred to as the engine backbone. The engine static structure 44 generally includes a fan case 46, an intermediate case (IMC) 48, a high pressure compressor case 50, a combustor case 52A, a high pressure turbine case 52B, a thrust case 52C, a low pressure turbine case 54, and a turbine exhaust case 56 (Figure 1B). Alternatively, the combustor case 52A, the high pressure turbine case 52B and the thrust case 52C may be combined into a single case. It should be understood that this is an exemplary configuration and any number of cases may be utilized.

The fan section 20 includes a fan rotor 32 with a plurality of circumferentially spaced radially outwardly extending fan blades 34. The fan blades 34 are surrounded by the fan case 46. The core engine case structure is secured to the fan case 46 at the IMC 48 which includes a multiple of circumferentially spaced radially extending struts 40 which radially span the core engine case structure and the fan case 20.

The engine static structure 44 further supports a bearing system upon which the turbines 28, 18, compressors 26, 16 and fan rotor 32 rotate. A #1 fan dual bearing 60 which rotationally supports the fan rotor 32 is axially located generally within the fan case 46. The #1 fan dual bearing 60 is preloaded to react fan thrust forward and aft (in case of surge). A #2 LPC bearing 62 which rotationally supports the low spool 14 is axially located generally within the intermediate case (IMC) 48. The #2 LPC bearing 62 reacts thrust. A #3 fan dual bearing 64 which rotationally supports the high spool 24 and also reacts thrust. The #3 fan bearing 64 is also axially located generally within the IMC 48 just forward of the high pressure compressor case 50. A #4 bearing 66 which rotationally supports a rear segment of the low spool 14 reacts only radial loads. The #4 bearing 66 is axially located generally within the thrust case 52C in an aft section thereof. A #5 bearing 68 rotationally supports the rear segment of the low spool 14 and reacts only radial loads. The #5 bearing 68 is axially located generally within the thrust case 52C just aft of the #4 bearing 66. It should be understood that this is an exemplary configuration and any number of bearings may be utilized.

The #4 bearing 66 and the #5 bearing 68 are supported within a mid-turbine frame (MTF) 70 to straddle radially extending structural struts 72 which are preloaded in tension (Figures 1C-1D). The MTF 70 provides aft structural support

within the thrust case 52C for the #4 bearing 66 and the #5 bearing 68 which rotatably support the spools 14, 24.

A dual rotor engine such as that disclosed in the illustrated embodiment typically includes a forward frame and a rear frame that support the main rotor bearings. The intermediate case (IMC) 48 also includes the radially extending struts 5 40 which are generally radially aligned with the #2 LPC bearing 62 (Figure 1B). It should be understood that various engines with various case and frame structures will benefit from the present invention.

The turbofan gas turbine engine 10 is mounted to aircraft structure such as an aircraft wing through a mount system 80 attachable by the pylon 12. The mount 10 system 80 includes a forward mount 82 and an aft mount 84 (Figure 2A). The forward mount 82 is secured to the IMC 48 and the aft mount 84 is secured to the MTF 70 at the thrust case 52C. The forward mount 82 and the aft mount 84 are arranged in a plane containing the axis A of the turbofan gas turbine 10. This 15 eliminates the thrust links from the intermediate case, which frees up valuable space beneath the core nacelle and minimizes IMC 48 distortion.

Referring to Figures 2A-2C, the mount system 80 reacts the engine thrust at the aft end of the engine 10. The term "reacts" as utilized in this disclosure is defined as absorbing a load and dissipating the load to another location of the gas turbine 20 engine 10.

The forward mount 82 supports vertical loads and side loads. The forward mount 82 in one non-limiting embodiment includes a shackle arrangement which mounts to the IMC 48 at two points 86A, 86B. The forward mount 82 is generally a plate-like member which is oriented transverse to the plane which contains engine 25 axis A. Fasteners are oriented through the forward mount 82 to engage the intermediate case (IMC) 48 generally parallel to the engine axis A. In this illustrated non-limiting embodiment, the forward mount 82 is secured to the IMC 40. In another non-limiting embodiment, the forward mount 82 is secured to a portion of the core engine, such as the high-pressure compressor case 50 of the gas turbine engine 30 10 (see Figure 3). One of ordinary skill in the art having the benefit of this disclosure would be able to select an appropriate mounting location for the forward mount 82.

Referring to Figure 4A, the aft mount 84 generally includes a first A-arm 88A, a second A-arm 88B, a rear mount platform 90, a wiffle tree assembly 92 and a

drag link 94. The rear mount platform 90 is attached directly to aircraft structure such as the pylon 12. The first A-arm 88A and the second A-arm 88B mount between the thrust case 52C at case bosses 96 which interact with the MTF 70 (Figures 4B-4C), the rear mount platform 90 and the wiffle tree assembly 92. It should be understood that the first A-arm 88A and the second A-arm 88B may alternatively mount to other areas of the engine 10 such as the high pressure turbine case or other cases. It should also be understood that other frame arrangements may alternatively be used with any engine case arrangement.

Referring to Figure 4D, the first A-arm 88A and the second A-arm 88B are rigid generally triangular arrangements, each having a first link arm 89a, a second link arm 89b and a third link arm 89c. The first link arm 89a is between the case boss 96 and the rear mount platform 90. The second link arm 89b is between the case bosses 96 and the wiffle tree assembly 92. The third link arm 89c is between the wiffle tree assembly 92 rear mount platform 90. The first A-arm 88A and the second A-arm 88B primarily support the vertical weight load of the engine 10 and transmit thrust loads from the engine to the rear mount platform 90.

The first A-arm 88A and the second A-arm 88B of the aft mount 84 force the resultant thrust vector at the engine casing to be reacted along the engine axis A which minimizes tip clearance losses due to engine loading at the aft mount 84. This minimizes blade tip clearance requirements and thereby improves engine performance.

The wiffle tree assembly 92 includes a wiffle link 98 which supports a central ball joint 100, a first sliding ball joint 102A and a second sliding ball joint 102B (Figure 4E). It should be understood that various bushings, vibration isolators and such like may additionally be utilized herewith. The central ball joint 100 is attached directly to aircraft structure such as the pylon 12. The first sliding ball joint 102A is attached to the first A-arm 88A and the second sliding ball joint 102B is mounted to the first A-arm 88A. The first and second sliding ball joint 102A, 102B permit sliding movement of the first and second A-arm 88A, 88B (illustrated by arrow S in Figures 5A and 5B) to assure that only a vertical load is reacted by the wiffle tree assembly 92. That is, the wiffle tree assembly 92 allows all engine thrust loads to be equalized transmitted to the engine pylon 12 through the rear mount platform 90 by the sliding movement and equalize the thrust load that results from the dual thrust

link configuration. The wiffle link 98 operates as an equalizing link for vertical loads due to the first sliding ball joint 102A and the second sliding ball joint 102B. As the wiffle link 98 rotates about the central ball joint 100 thrust forces are equalized in the axial direction. The wiffle tree assembly 92 experiences loading only due to vertical
5 loads, and is thus less susceptible to failure than conventional thrust-loaded designs.

The drag link 94 includes a ball joint 104A mounted to the thrust case 52C and ball joint 104B mounted to the rear mount platform 90 (Figures 4B-4C). The drag link 94 operates to react torque.

The aft mount 84 transmits engine loads directly to the thrust case 52C and
10 the MTF 70. Thrust, vertical, side, and torque loads are transmitted directly from the MTF 70 which reduces the number of structural members as compared to current in-practice designs.

The mount system 80 is compact, and occupies space within the core nacelle volume as compared to turbine exhaust case-mounted configurations, which occupy
15 space outside of the core nacelle which may require additional or relatively larger aerodynamic fairings and increase aerodynamic drag and fuel consumption. The mount system 80 eliminates the heretofore required thrust links from the IMC, which frees up valuable space adjacent the IMC 48 and the high pressure compressor case 50 within the core nacelle C.

20 It should be understood that relative positional terms such as "forward," "aft," "upper," "lower," "above," "below," and the like are with reference to the normal operational attitude of the vehicle and should not be considered otherwise limiting.

The foregoing description is exemplary rather than defined by the limitations within. Many modifications and variations of the present invention are possible in
25 light of the above teachings. The disclosed embodiments of this invention have been disclosed, however, one of ordinary skill in the art would recognize that certain modifications would come within the scope of this invention. It is, therefore, to be understood that within the scope of the appended claims, the invention may be practiced otherwise than as specifically described. For that reason the following
30 claims should be studied to determine the true scope and content of this invention.

CLAIMS

What is claimed is:

1. A gas turbine engine comprising:
5 a core nacelle defined about an engine centerline axis;
a fan nacelle mounted at least partially around said core nacelle to define a fan bypass airflow path for a fan bypass airflow;
a gear train defined along an engine centerline axis, said gear train defines a gear reduction ratio of greater than or equal to about 2.3;
10 a spool along said engine centerline axis which drives said gear train, said spool includes a three to six (3-6) stage low pressure turbine; and
a fan variable area nozzle axially movable relative to said fan nacelle to vary a fan nozzle exit area and adjust a pressure ratio of the fan bypass airflow during engine operation.
15
2. The engine as recited in claim 1, wherein said spool is a low spool.
3. The engine as recited in claim 1, wherein said low pressure turbine defines a pressure ratio that is greater than about five (5).
20
4. The engine as recited in claim 1, wherein said low pressure turbine defines a pressure ratio that is greater than five (5).
5. The engine as recited in claim 1, wherein said fan bypass airflow defines a
25 bypass ratio greater than about ten (10).
6. The engine as recited in claim 1, wherein said fan bypass airflow defines a bypass ratio greater than ten (10).
- 30 7. The engine as recited in claim 1, wherein said gear train defines a gear reduction ratio of greater than or equal to about 2.5.

8. The engine as recited in claim 1, wherein said gear train defines a gear reduction ratio of greater than or equal to 2.5.
9. The engine as recited in claim 1, further comprising:
5 a controller operable to control said fan variable area nozzle to vary the fan nozzle exit area and adjust the pressure ratio of the fan bypass airflow.
10. The engine as recited in claim 9, wherein said controller is operable to reduce said fan nozzle exit area at a cruise flight condition.
10
11. The engine as recited in claim 9, wherein said controller is operable to control said fan nozzle exit area to reduce a fan instability.
12. The engine as recited in claim 1, wherein said fan variable area nozzle defines
15 a trailing edge of said fan nacelle.
13. The engine as recited in claim 1, wherein said gear train drives a fan within said fan nacelle.
- 20 14. A gas turbine engine comprising:
a gear train defined along an engine centerline axis, said gear train defines a gear reduction ratio of greater than or equal to about 2.3; and
a spool along said engine centerline axis which drives said gear train, said spool includes a three to six (3-6) stage low pressure turbine.
25
15. The engine as recited in claim 14, wherein said low pressure turbine is a three (3) stage low pressure turbine.
16. The engine as recited in claim 14, wherein said low pressure turbine is a five
30 (5) stage low pressure turbine.

17. The engine as recited in claim 14, wherein said low pressure turbine is a six (6) stage low pressure turbine
18. The engine as recited in claim 14, wherein said low pressure turbine defines a pressure ratio that is greater than about five (5).
19. The engine as recited in claim 14, wherein said spool drives a fan through said gear train, said fan defines a fan bypass airflow having a bypass ratio greater than about ten (10).
20. The engine as recited in claim 14, wherein said gear train defines a gear reduction ratio of greater than or equal to about 2.5.
21. The engine as recited in claim 14, wherein said low pressure turbine defines a pressure ratio that is greater than five (5), said spool drives a fan through said gear train, said fan defines a fan bypass airflow having a bypass ratio greater than ten (10), and said gear train defines a gear reduction ratio of greater than or equal to 2.5.

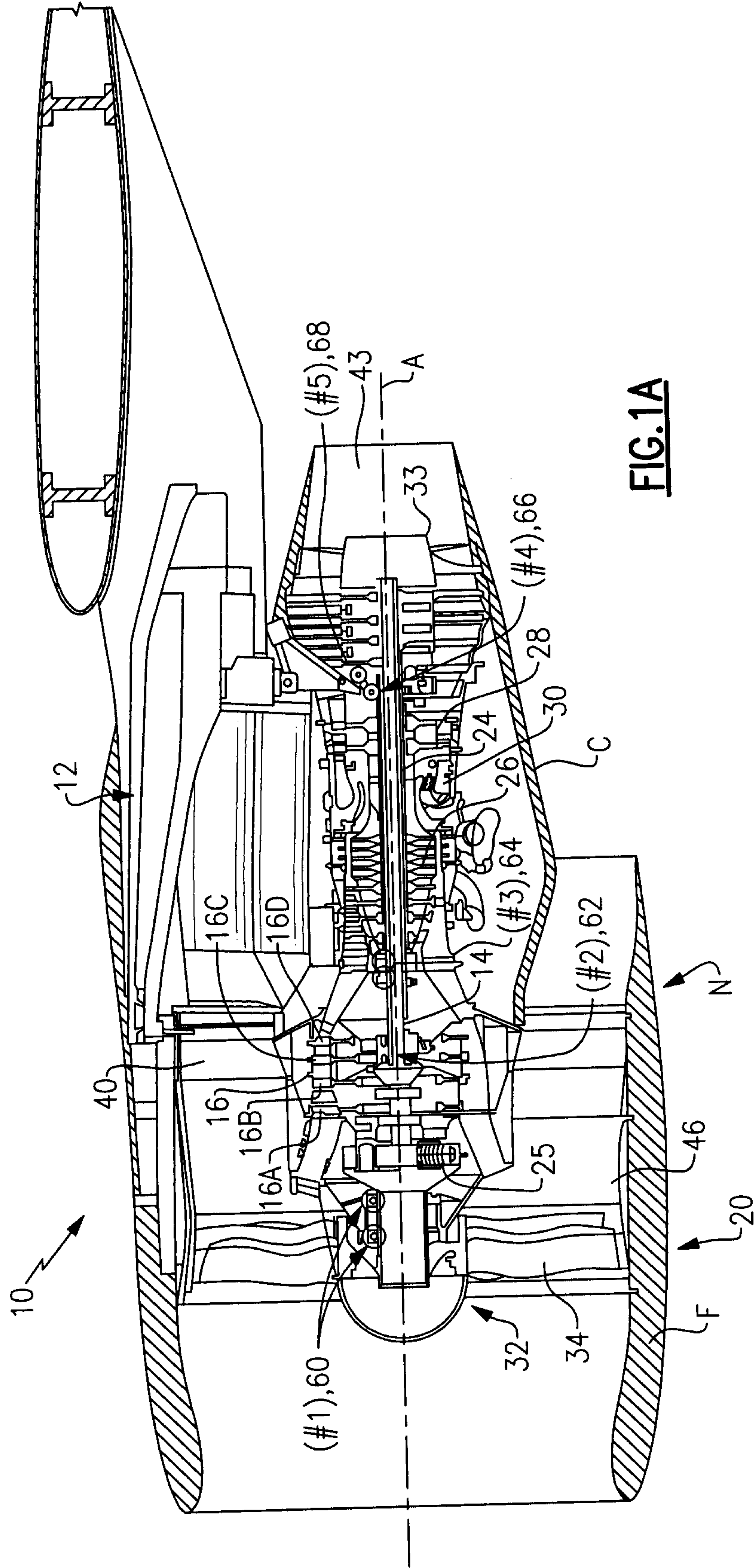

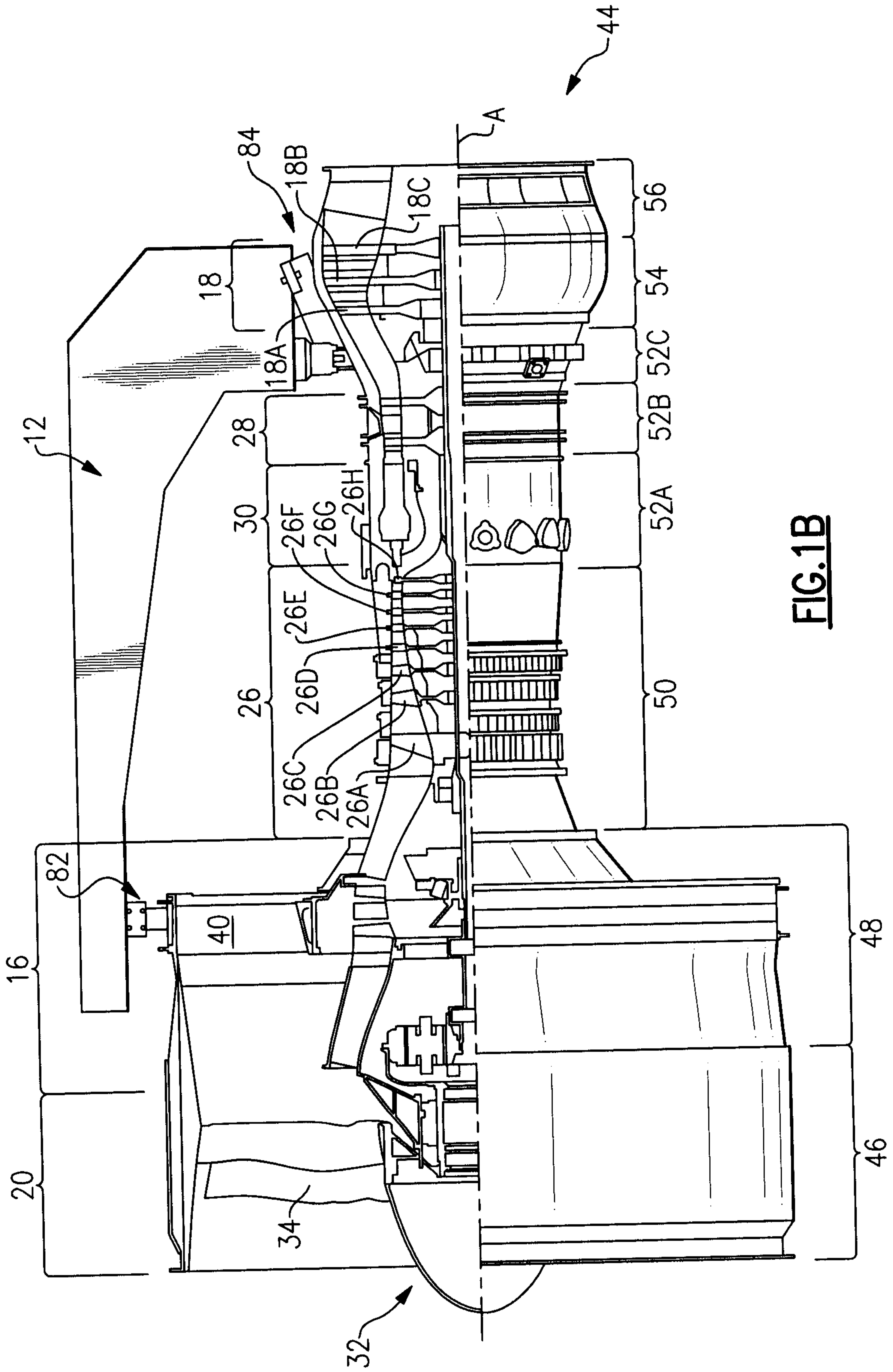

FIG. 1B

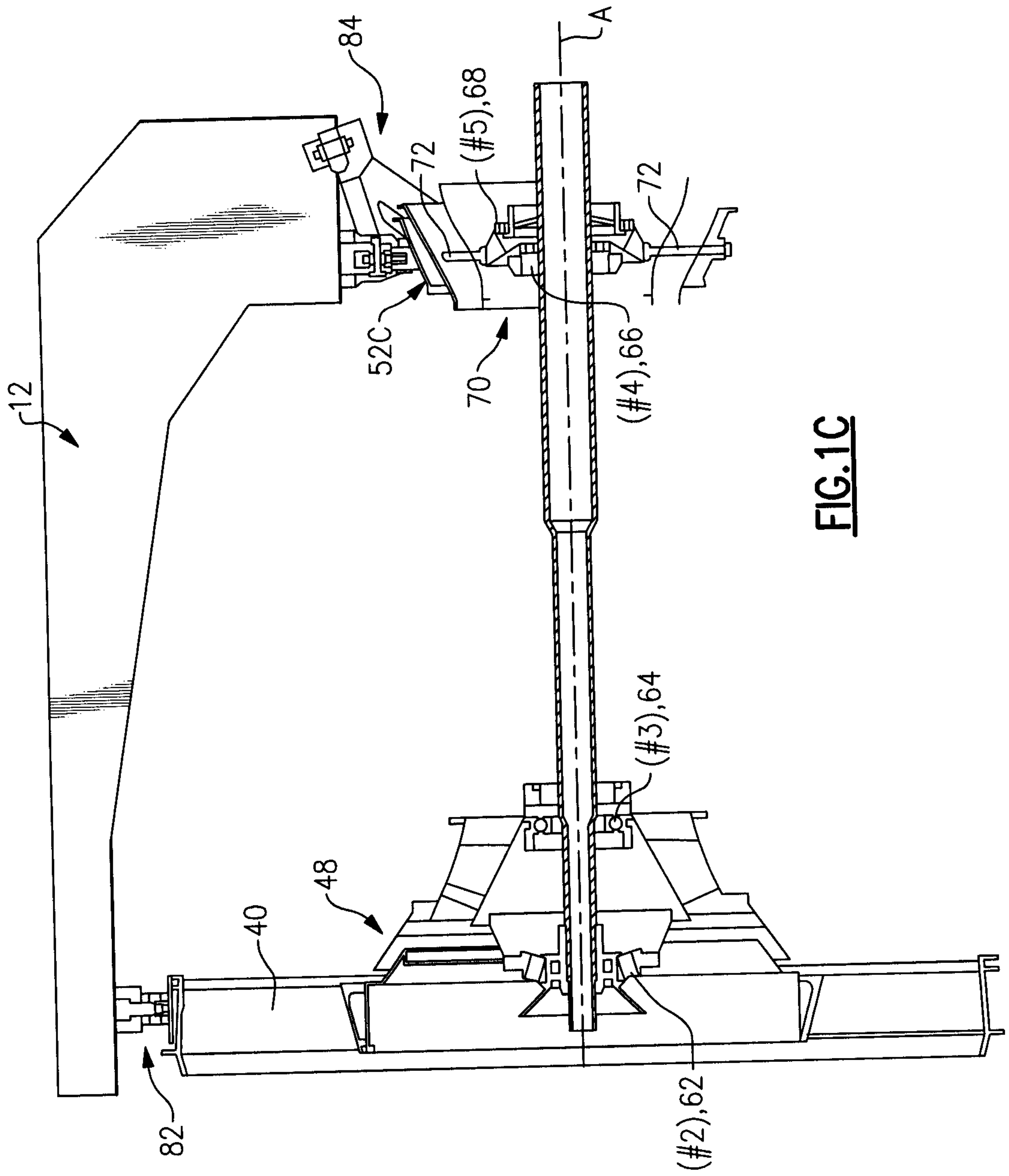

FIG.1C

4/11

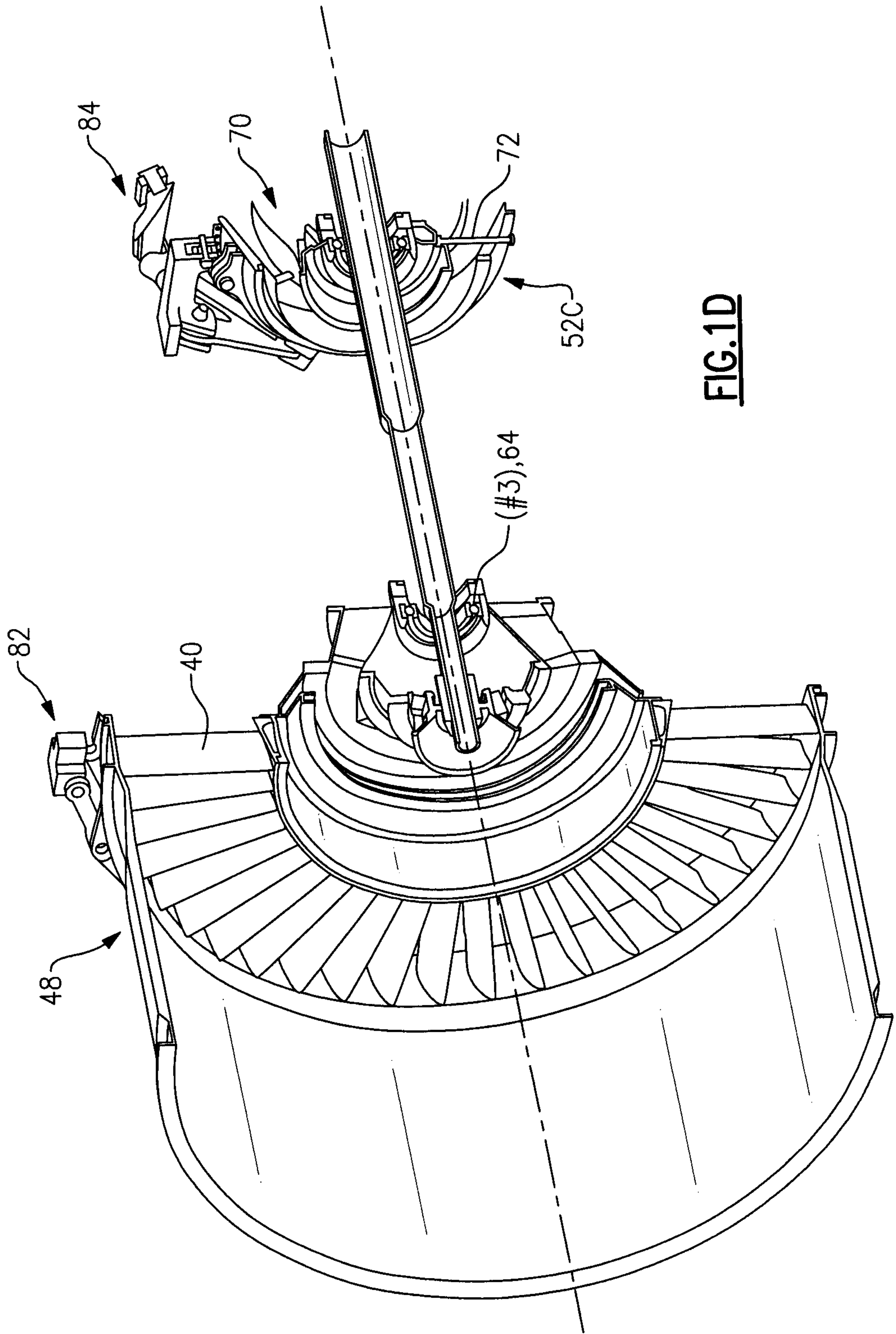

FIG. 1D

5/11

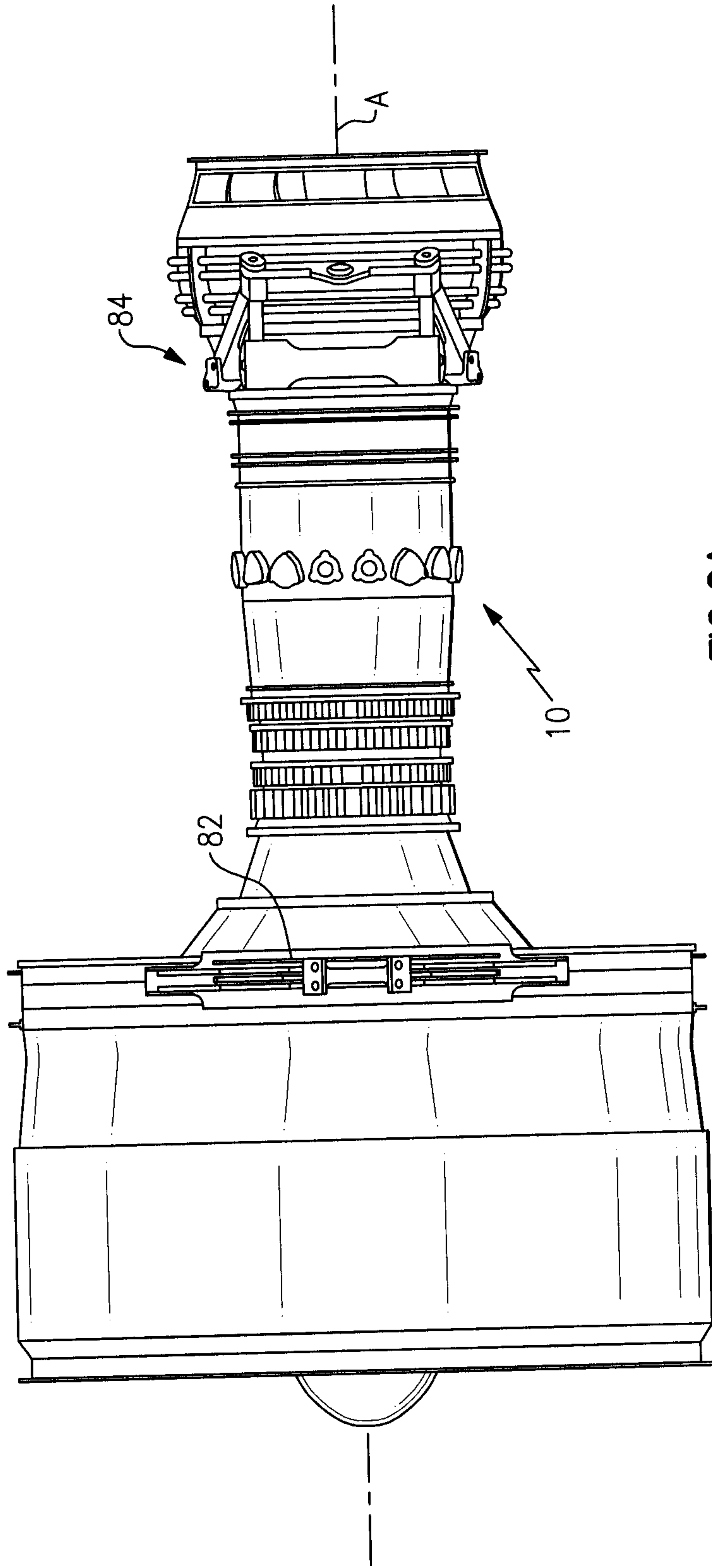
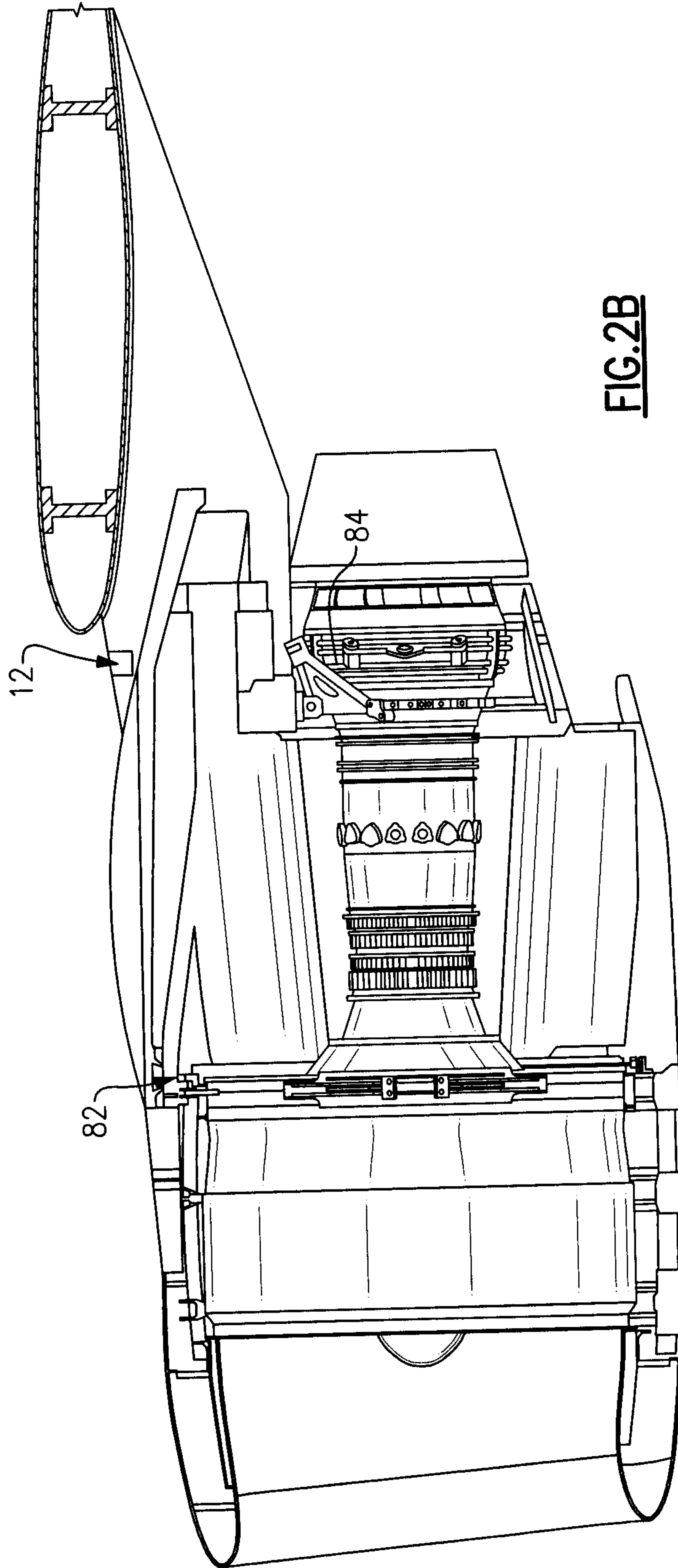

FIG. 2A

6/11



7/11

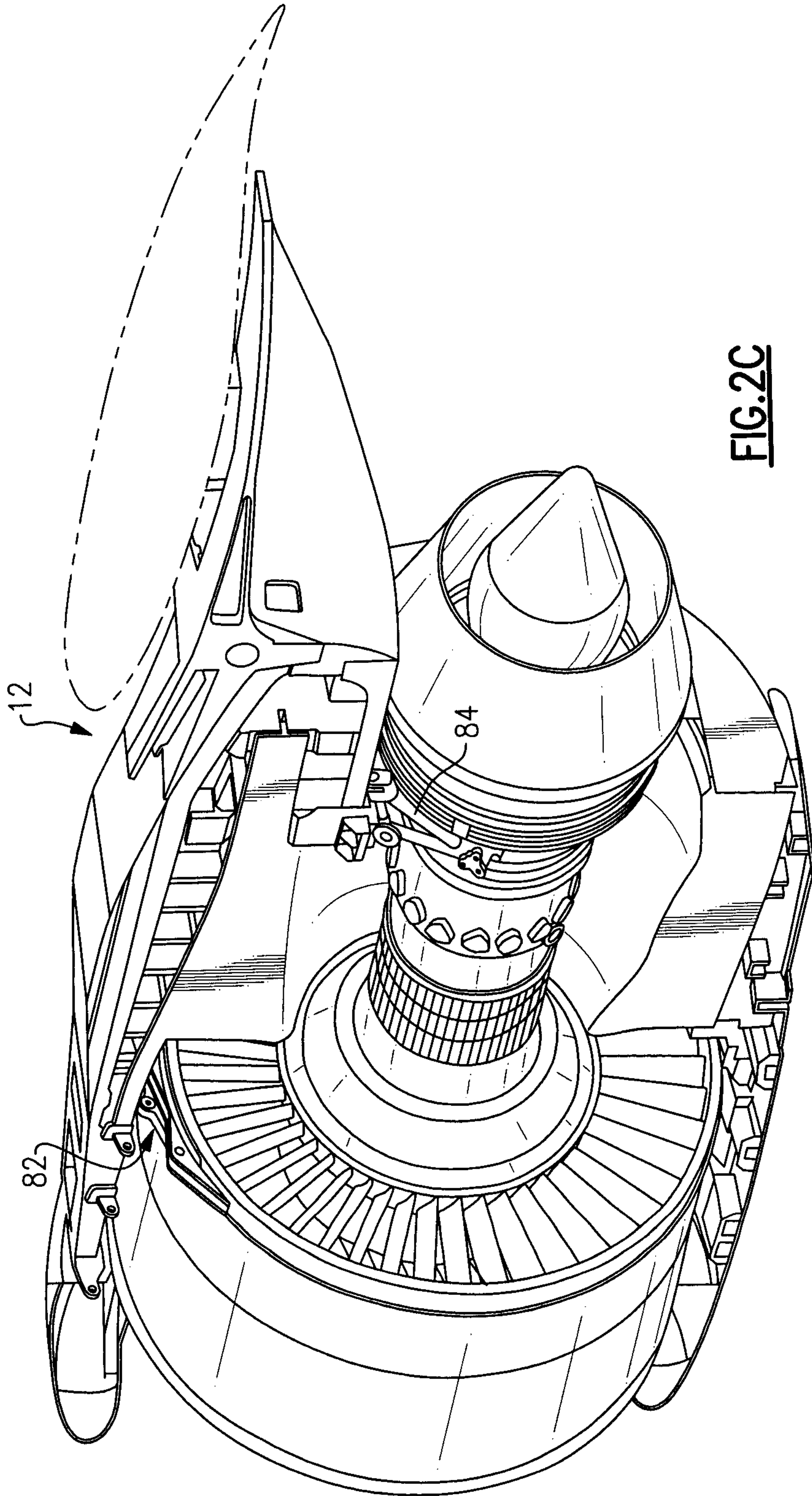
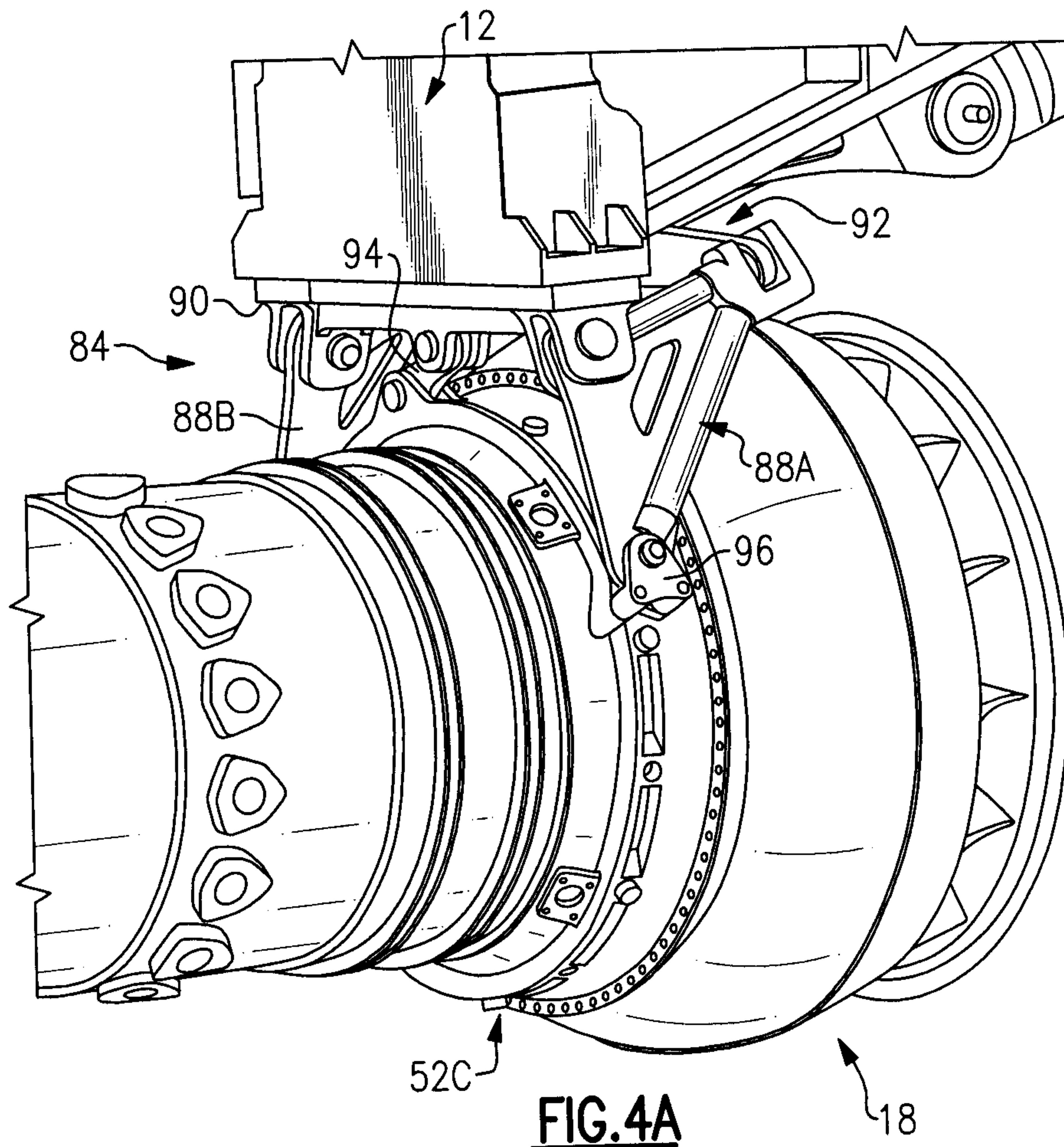
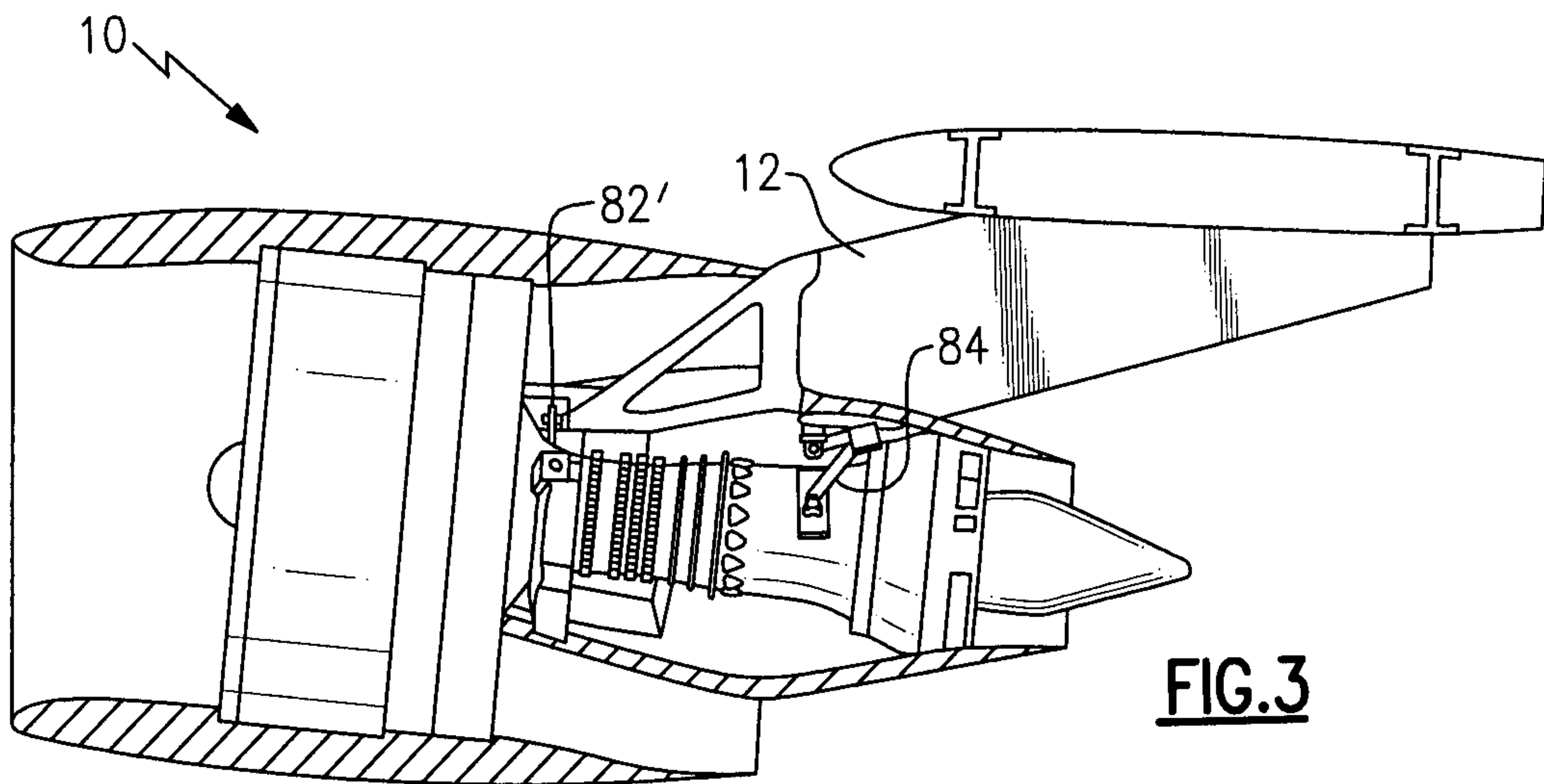
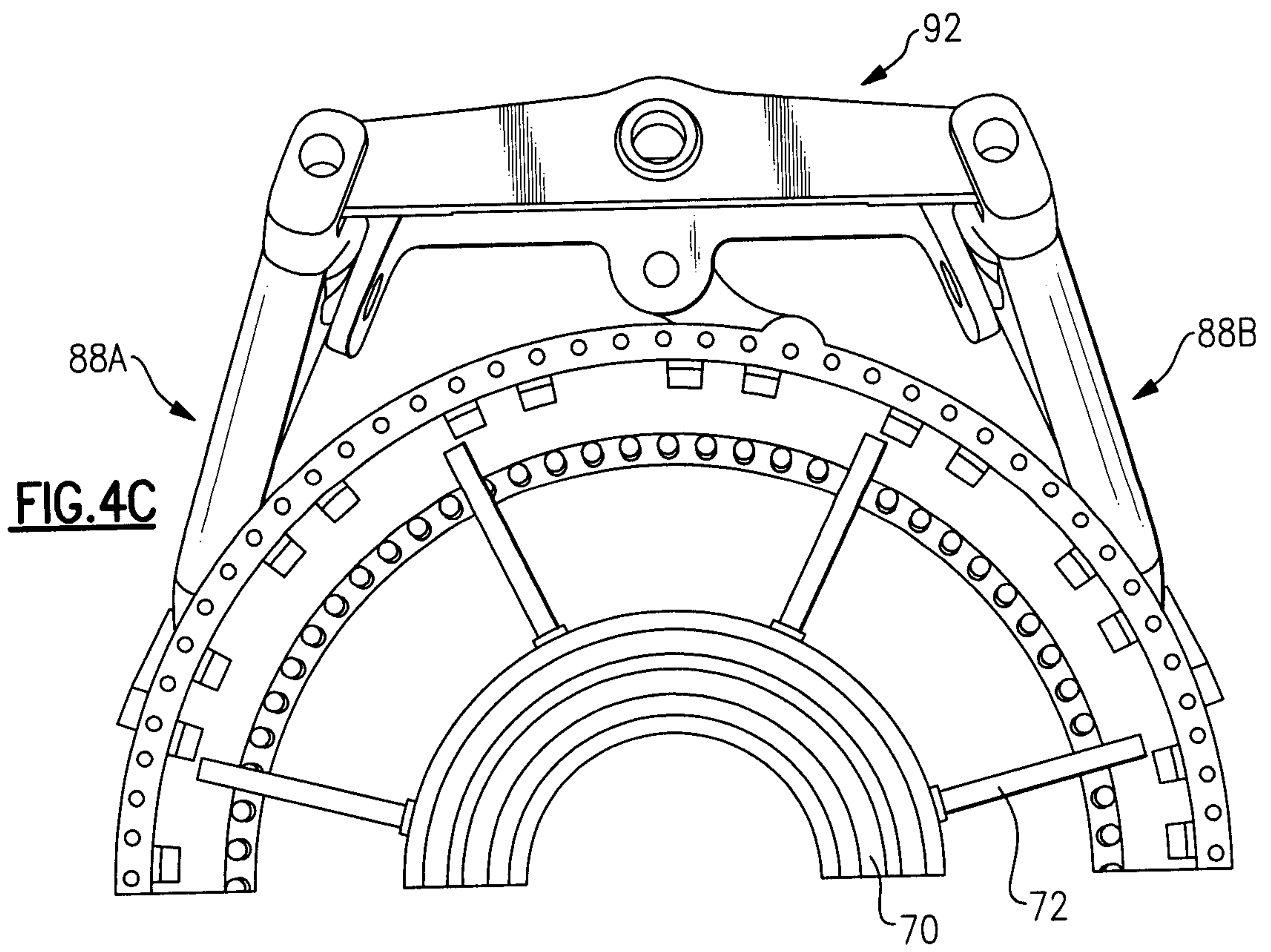
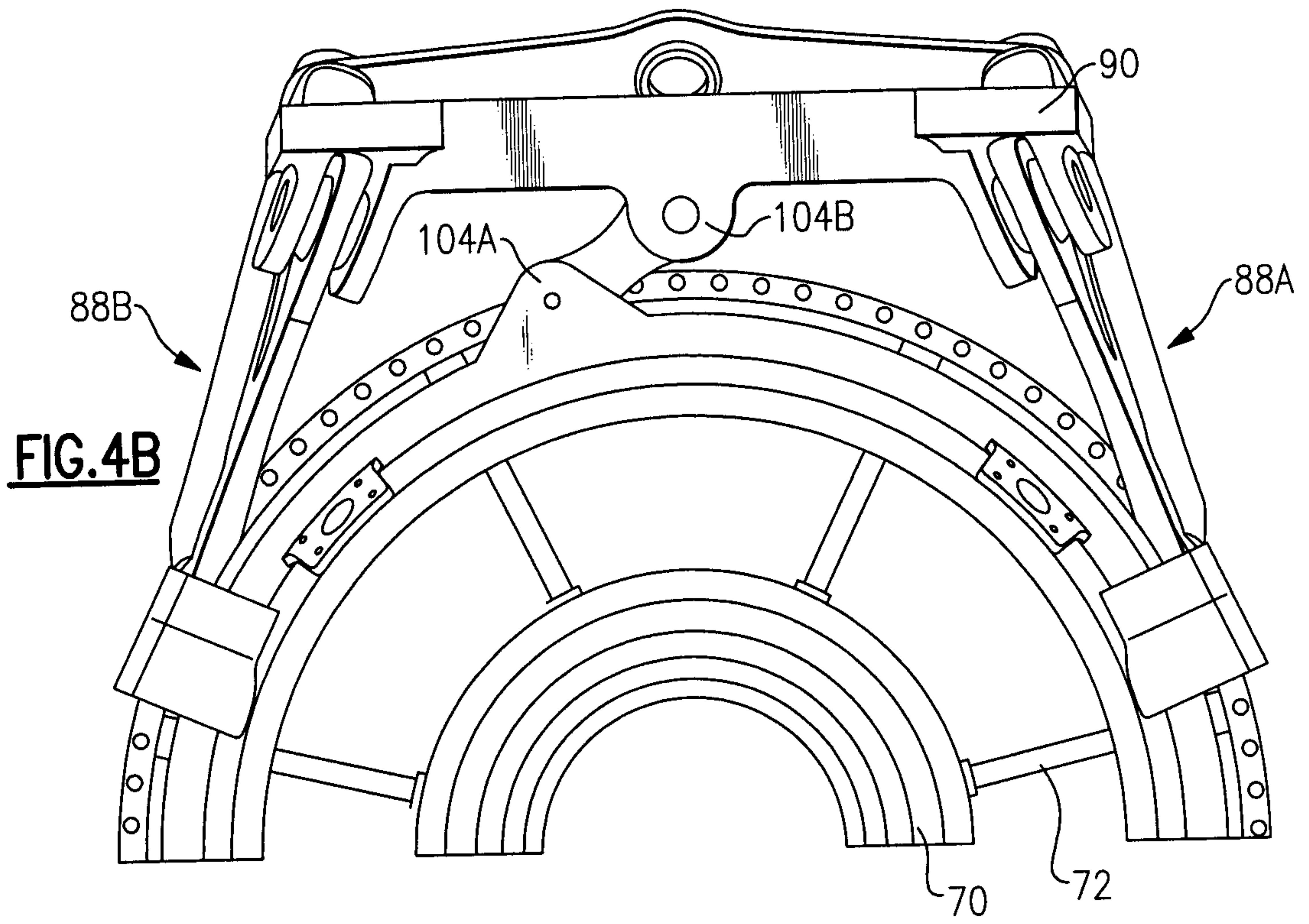

FIG. 2C

8/11



9/11



10/11

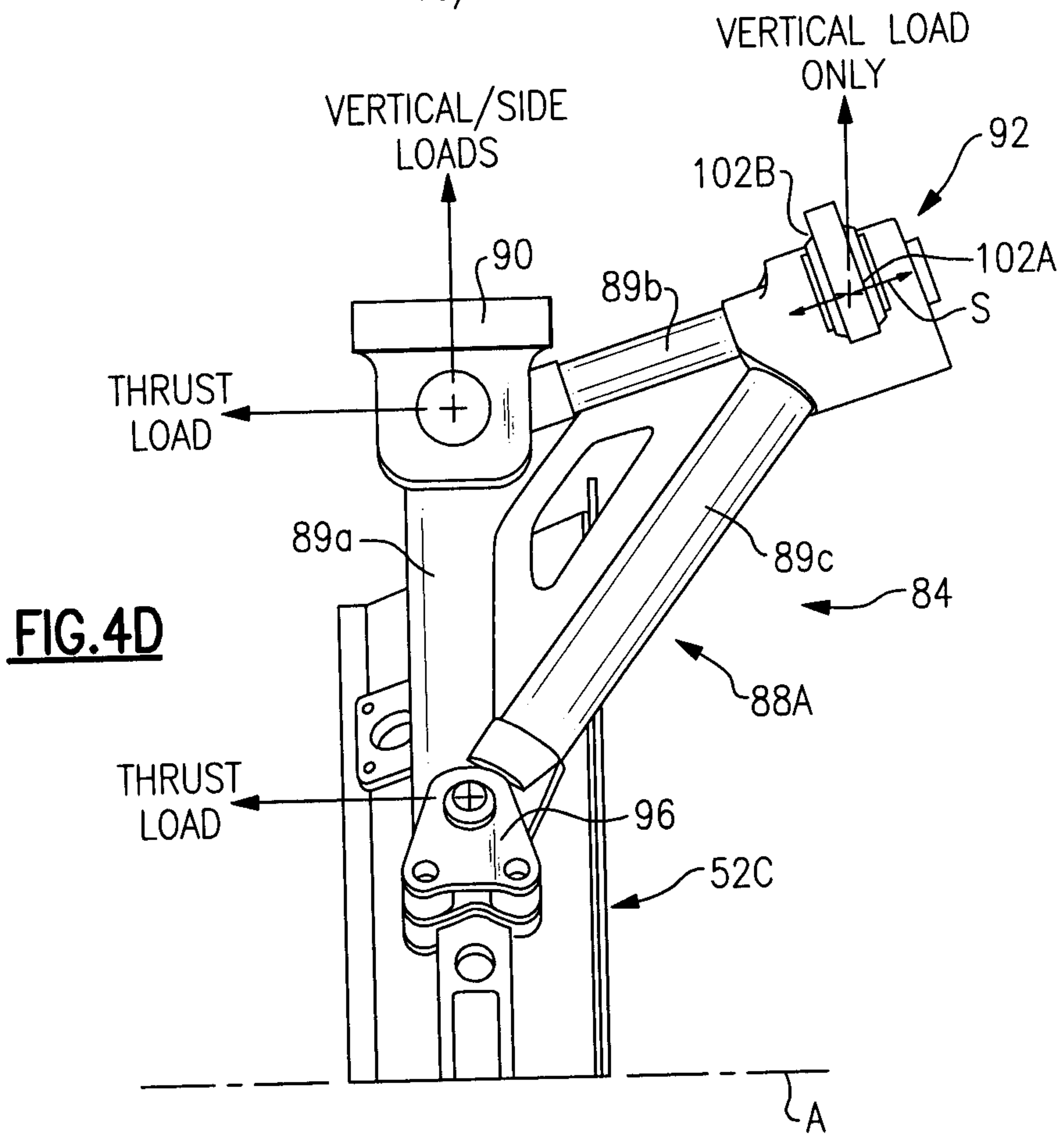

FIG. 4D

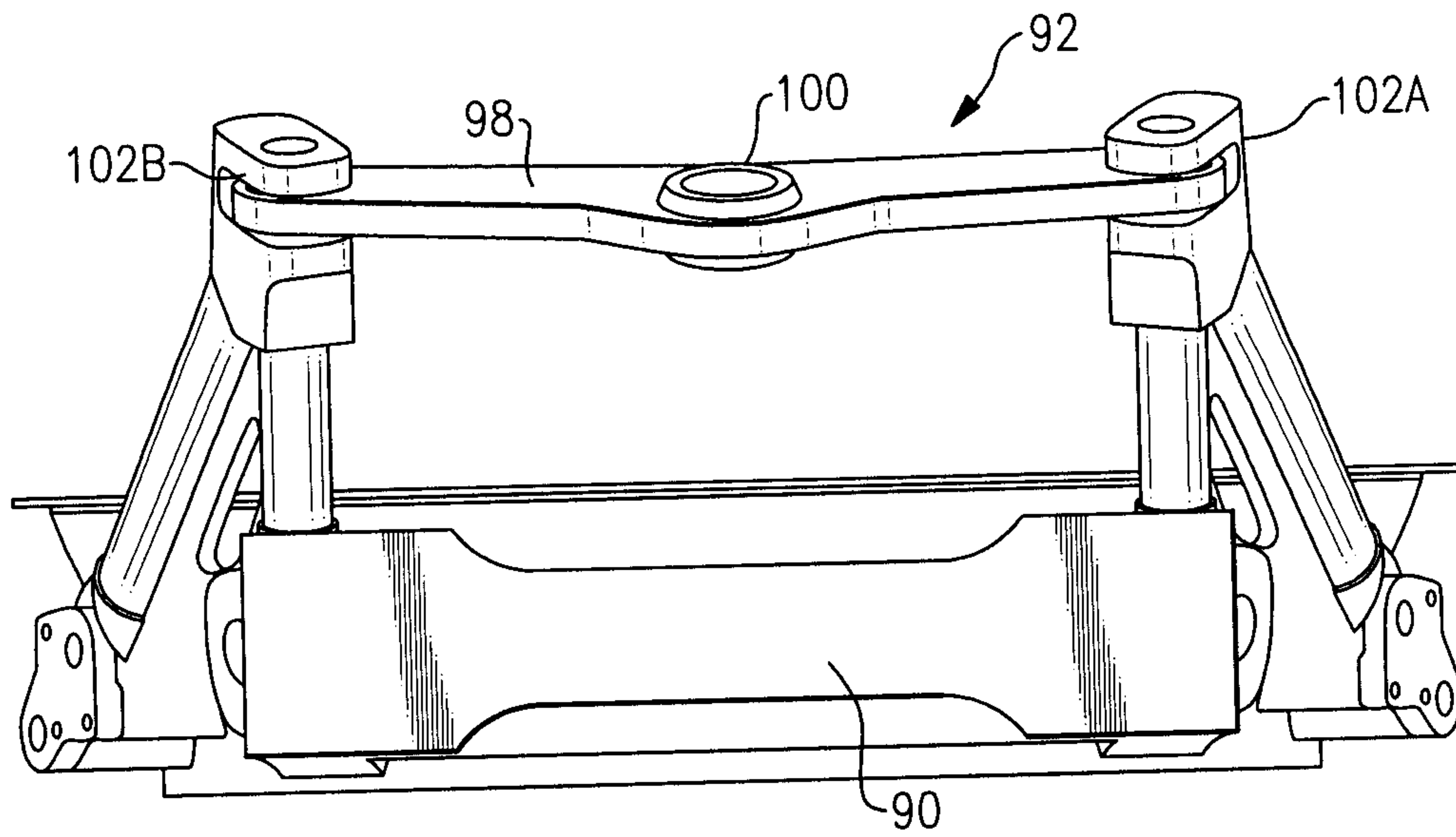

FIG. 4E

11/11

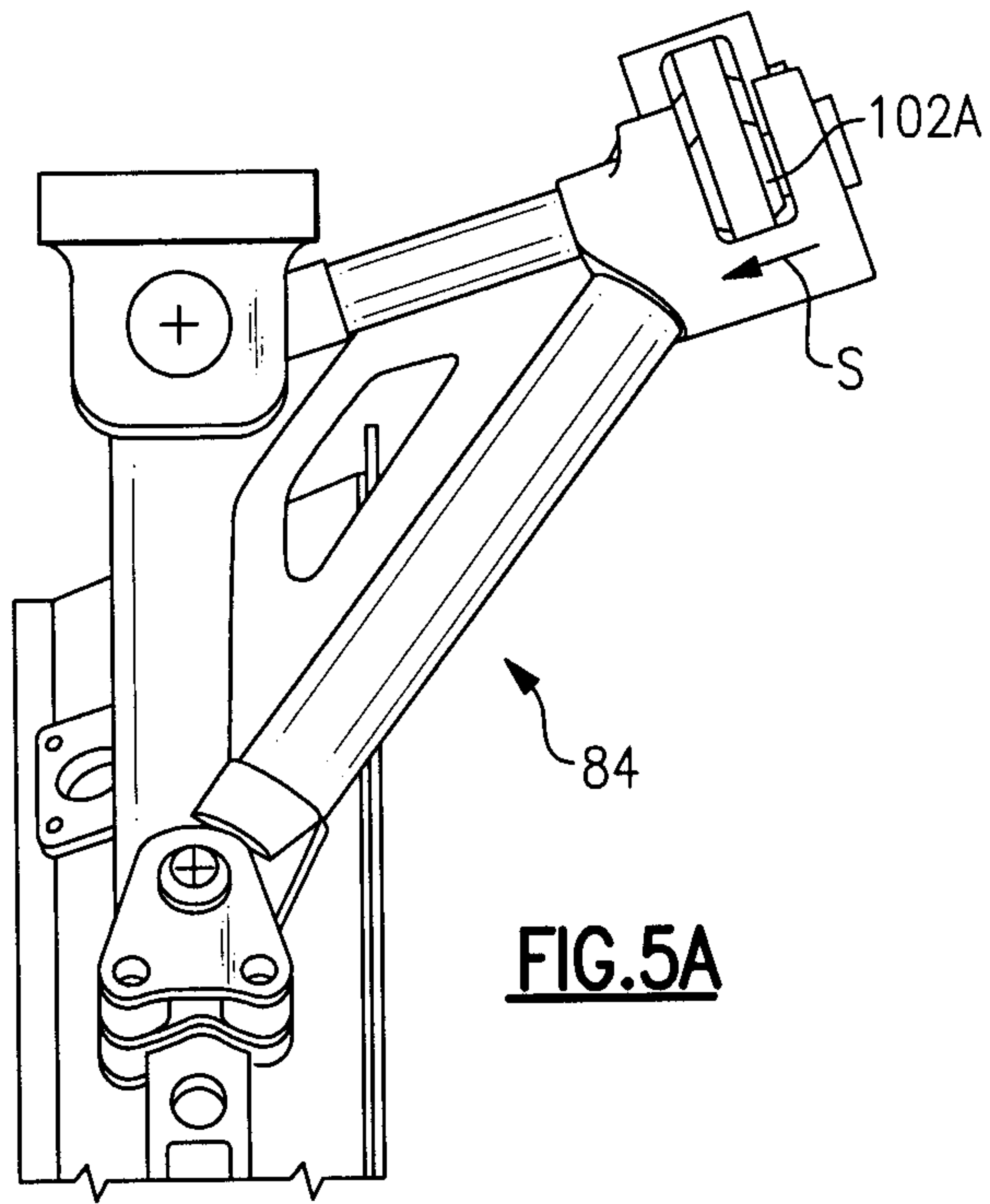

FIG. 5A

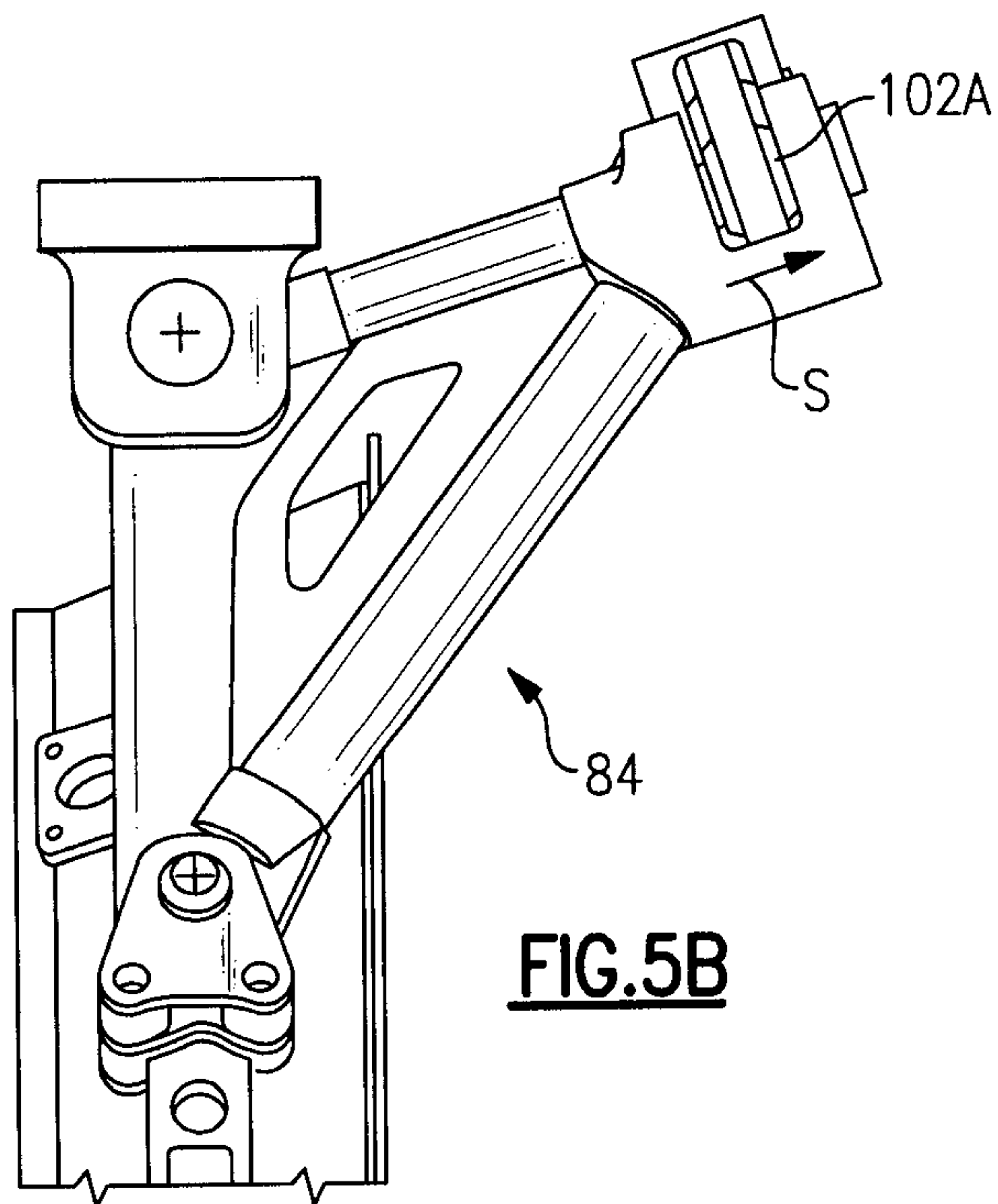

FIG. 5B

