

Aug. 27, 1963

J. R. McCORMICK

3,101,704

SLINGSHOT

Filed Feb. 19, 1962

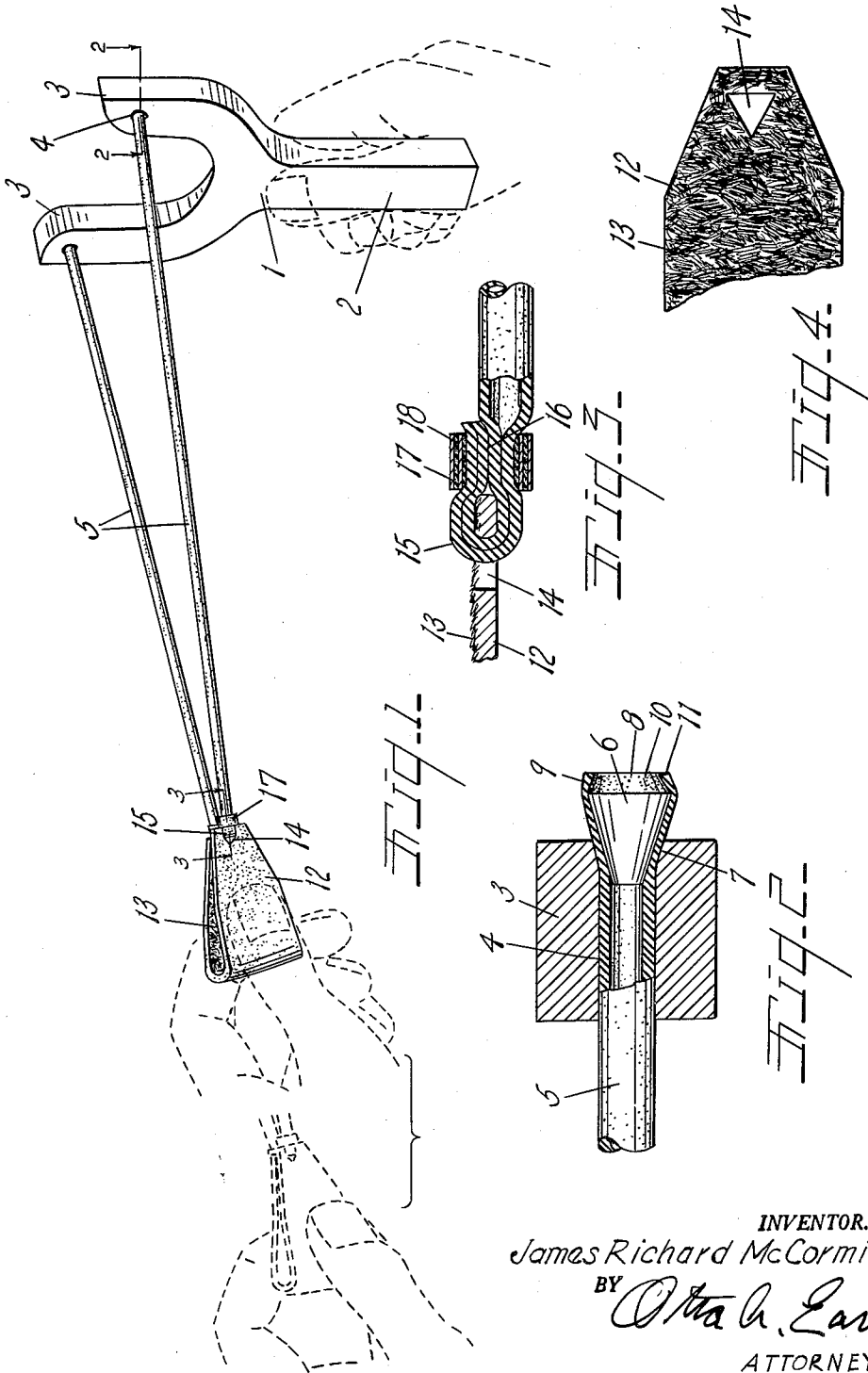

INVENTOR.
James Richard McCormick
BY *Otha L. Earl*
ATTORNEY.

1

3,101,704
SLINGSHOT

James Richard McCormick, R.R. 1, Allegan, Mich.
Filed Feb. 19, 1962, Ser. No. 173,917
11 Claims. (Cl. 124-20)

This invention relates to slingshots. The main objects of this invention are,

First, to provide a slingshot which is highly efficient and at the same time structurally simple.

Second, to provide a slingshot formed of relatively few parts, the parts being assembled so as to minimize stresses tending to break the connections for the parts.

Objects relating to details and economies of the invention will appear from the description to follow. The invention is defined and pointed out in the claims.

A preferred embodiment of the invention is illustrated in the accompanying drawing, in which:

FIG. 1 is a perspective view of a slingshot embodying my invention, hands of a user being indicated by dotted lines.

FIG. 2 is an enlarged fragmentary view partially in section on a line corresponding to line 2-2 of FIG. 1.

FIG. 3 is an enlarged fragmentary view partially in section on a line corresponding to line 3-3 of FIG. 1.

FIG. 4 is a fragmentary view of a fingerpiece and projectile holder.

It will be noted that the illustration of FIG. 1 illustrates applicant's slingshot as being used by a left handed person.

The slingshot embodying the applicant's invention comprises a forked handle designated generally by the numeral 1 and comprising the grip portion 2 and upwardly projecting laterally spaced arms 3 which have bores 4 therethrough, these bores being disposed adjacent but in downwardly spaced relation relative to the upper ends of the arms.

The elongated tubular elastic members 5 are disposed through the bores or holes 4 in the arms 3 being a slidable fit therein, that is, the bores 4 are of such dimensions that the ends of the elastic members may be inserted therethrough and project forwardly therefrom to receive the conical clutch or anchor members 6. The taper and dimensions of these anchor or clutch members are such that their inner ends project substantially into the bores 4 when the members 6 are inserted in the front end of the members 5, see FIG. 2, so that pulling stress on the members 5 results in compressing clutching engagement thereof with the forwardly facing beveled portion 7 of the bore 4. The taper angle of said bores is substantially that of said bevels.

In the desirable embodiment illustrated, the member 6 has an inwardly beveled outer end portion 8 with which the outer end 9 of the elastic member 5 is in clutching engagement. Desirably adhesive is applied to this surface 8 as indicated at 10 which prevents any stripping off as a result of the forward edge 11 being engaged with some object, not as a use, but in the matter of handling.

The combined fingerpiece and projectile holder 12 is desirably formed of leather which has an inner surface 13 with projecting filaments, as is illustrated conventionally in FIG. 3. This member 12 has holes 14 at the ends thereof through which the inner end portions 15 of the members 5 are inserted with the portions 15 collapsed, the collapsed portion being disposed in side by side relation at 16 and fixedly secured together by the strips 17 wound around the same, the strips having adhesive 18 on their inner sides which bonds the strips to the parts around which they are wrapped and also the convolutions of the strips are bonded together. The elastic tubular members 5 are thus connected to the

2

fingerpiece and projectile holder. The tubular stretchable members 5 are connected both to the handle and to the fingerpiece in a wholly effective manner and in a manner which minimizes tearing or rupturing stress on the elastic material.

I have illustrated and described my invention in a highly practical embodiment thereof. I have not attempted to illustrate modifications which might be desirable in the form of the handpiece or in the fingerpiece and projectile holder, as it is believed that this disclosure will enable those skilled in the art to embody or adapt my invention as may be desired.

Having thus described the invention, what is claimed as new and desired to secure by Letters Patent is:

1. A slingshot comprising a forked handle, the arms of which have cylindrical bores therethrough adjacent but spaced downwardly from their upper ends the forward ends of said bores being beveled, a pair of elongated tubular elastic members disposed through said bores with their ends projecting forwardly from said arms, conical clutch members disposed in the forwardly projecting ends of said tubular elastic members and having inner portions of less diameter than the bores of said arms and outer portions of substantial length of a diameter substantially exceeding the diameter of the bores, the taper angle of said clutch members being substantially that of said bevels, said clutch members also having inwardly beveled outer ends, the outer ends of said tubular elastic members being in overlapping clutching engagement with said beveled portions of said clutch members and being adhesively secured thereto, a combined fingerpiece and projectile holder of flexible material having openings adjacent the ends thereof, the inner ends of said tubular elastic members being collapsed and looped through said openings with collapsed portions thereof in overlapping relation at the ends of said fingerpiece and projectile holder, the collapsed overlapping portions of said tubular members being clampingly secured together by strips of substantial width wrapped therearound.

2. A slingshot comprising a forked handle, the arms of which have cylindrical bores therethrough adjacent but spaced downwardly from their upper ends, the forward ends of said bores being beveled, a pair of elongated tubular elastic members disposed through said bores with their ends projecting forwardly from said arms, conical clutch members disposed in the forwardly projecting ends of said tubular elastic members and having inner portions of less diameter than the bores of said arms and outer portions of substantial length of a diameter substantially exceeding the diameter of the bores, the taper angle of said clutch members being substantially that of said bevels, the outer ends of said tubular elastic members being in overlapping clutching engagement with outer end portions of said clutch members, a combined fingerpiece and projectile holder of flexible material having openings adjacent the ends thereof, the inner ends of said tubular elastic members being collapsed and looped through said openings with collapsed portions thereof in overlapping relation at the ends of said fingerpiece and projectile holder, the collapsed overlapping portions of said tubular members being clampingly secured together by strips of substantial width wrapped therearound.

3. A slingshot comprising a forked handle, the arms of which have cylindrical bores therethrough adjacent but spaced downwardly from their upper ends, the forward ends of said bores being beveled, a pair of elongated tubular elastic members disposed through said bores with their ends projecting forwardly from said arms, conical clutch members disposed in the forwardly projecting ends of said tubular elastic members and having inner portions of less diameter than the bores of said arms and outer portions of substantial length of a diameter sub-

3

stantially exceeding the diameter of the bores, the taper angle of said clutch members being substantially that of said bevels, the outer ends of said tubular elastic members being in overlapping clutching engagement with outer end portions of said clutch members, a combined fingerpiece and projectile holder of flexible material having openings adjacent the ends thereof, the inner ends of said tubular elastic members being collapsed and looped through said openings with collapsed portions thereof in overlapping relation at the ends of said fingerpiece and projectile holder, the collapsed overlapping portions of said tubular members being clampingly secured together by strips of substantial width wrapped therearound, the strips having adhesive on their inner sides whereby they are adhesively bonded to said overlapping portions and the convolutions thereof are adhesively bonded together.

4. A slingshot comprising a forked handle, the arms of which have cylindrical bores therethrough adjacent but spaced downwardly from their upper ends, a pair of elongated tubular elastic members disposed through said bores with their ends projecting forwardly from said arms, conical clutch members disposed in the forwardly projecting ends of said tubular elastic members and having inner portions of less diameter than the bores of said arms and outer portions of substantial length of a diameter substantially exceeding the diameter of the bores, said clutch members also having inwardly beveled outer ends, the outer ends of said tubular elastic members being in overlapping contracting engagement with said beveled portions of said clutch members and being adhesively secured thereto, and a combined fingerpiece and projectile holder to which the inner ends of said elastic members are fixedly connected.

5. A slingshot comprising a forked handle, the arms of which have cylindrical bores therethrough adjacent but spaced downwardly from their upper ends, a pair of elongated tubular elastic members disposed through said bores with their ends projecting forwardly from said arms, conical clutch members disposed in the forwardly projecting ends of said tubular elastic members and having inner portions of less diameter than the bores of said arms projecting into said bores to clampingly engage said elastic members within said bores and outer portions of substantial length of a diameter substantially exceeding the diameter of the bores, and a combined fingerpiece and projectile holder to which the inner ends of said elastic members are fixedly connected.

6. A slingshot comprising a forked handle, the arms of which have cylindrical bores therethrough adjacent but spaced downwardly from their upper ends, a pair of elongated tubular elastic members disposed through said bores with their ends projecting forwardly from said arms, conical clutch members disposed in the forwardly projecting ends of said tubular elastic members and having inner end portions of less diameter than the bores of said arms projecting into said bores to clampingly engage said elastic members within said bores and outer portions of substantial length of a diameter substantially exceeding the diameter of the bores, a combined fingerpiece and projectile holder of flexible material having openings adjacent the ends thereof, the inner ends of said elastic members being collapsed and looped through said openings with collapsed portions thereof in overlapping relation at the ends of said fingerpiece and projectile holder, the collapsed overlapping portions of said tubular members being clampingly secured together by strips of substantial width wrapped therearound, the strips having adhesive on their inner sides whereby they are adhesively bonded to said overlapping portions and the convolutions thereof are adhesively bonded together.

7. A slingshot comprising a forked handle, the arms of which have cylindrical bores therethrough adjacent but spaced downwardly from their upper ends, a pair of elongated tubular elastic members disposed through said bores with their ends projecting forwardly from said arms, conical clutch members disposed in the forwardly projecting ends of said tubular elastic members and having inner portions of less diameter than the bores of said arms and outer portions of substantial length of a diameter substantially exceeding the diameter of the bores, said clutch members also having inwardly beveled outer ends, the outer ends of said tubes being in overlapping clutching engagement with said beveled portions of said clutch members and being adhesively secured thereto, a combined fingerpiece and projectile holder of flexible material having openings adjacent the ends thereof, the inner ends of said elastic members being collapsed and looped through said openings with collapsed portions thereof in overlapping relation at the ends of said fingerpiece and projectile holder, the collapsed overlapping portions of said tubular members being secured together by strips wrapped therearound.

8. A slingshot comprising a forked handle, the arms of which have cylindrical bores therethrough adjacent but spaced downwardly from their upper ends, a pair of elongated tubular elastic members disposed through said bores with their ends projecting forwardly from said arms, conical clutch members disposed in the forwardly projecting ends of said tubular elastic members and having inner end portions of less diameter than the bores of said arms and outer portions of substantial length of a diameter substantially exceeding the diameter of the bores, said clutch members also having inwardly beveled outer ends, the outer ends of said tubes being in overlapping clutching engagement with said beveled portions of said clutch members and being adhesively secured thereto, a combined fingerpiece and projectile holder of flexible material having openings adjacent the ends thereof, the inner ends of said elastic members being collapsed and looped through said openings with collapsed portions thereof in overlapping relation at the ends of said fingerpiece and projectile holder, the collapsed overlapping portions of said tubular members being secured together by strips wrapped therearound.

9. A slingshot comprising a forked handle, the arms of which have cylindrical bores therethrough adjacent but spaced downwardly from their upper ends, said bores having beveled outer end portions, a pair of elongated tubular elastic members the forward ends of which are disposed through said bores in forwardly projecting relation to said arms, conical anchoring members disposed in the outer ends of said tubular members and having inner end portions of less diameter than the said beveled ends of said bores of said arms and outer portions of substantial length substantially exceeding the diameter of said bores, a combined fingerpiece and projectile holder of flexible material connected to the inner ends of said elastic members, said holder having a nap-like inner surface.

10. A slingshot comprising a forked handle, the arms of which have cylindrical bores therethrough adjacent but spaced downwardly from their upper ends, said bores having beveled outer end portions, a pair of elongated tubular elastic members the forward ends of which are disposed through said bores in forwardly projecting relation to said arms, conical anchoring members disposed in the outer ends of said tubular members and having inner end portions of less diameter than the said beveled ends of said bores of said arms and outer portions of substantial length substantially exceeding the diameter of said bores, and a combined fingerpiece and projectile holder of flexible material connected to the inner ends of said elastic members.

11. A slingshot comprising a forked handle, the arms of which have cylindrical bores therethrough adjacent but spaced downwardly from their upper ends, a pair of elongated tubular elastic members the forward ends of which are disposed through said bores and secured to said arms, a combined fingerpiece and projectile holder of flexible material having a nap-like inner surface and

4

75

5

having openings adjacent the ends thereof, the inner ends of said elastic members being disposed through said openings and collapsed, and clamps being collapsed and disposed through said openings with collapsed portions thereof in overlapping condition forwardly of the ends of the fingerpiece and projectile holder and the overlapping ends clamped together by strips having adhesive on their inner sides whereby they are adhesively secured to said

5

6

overlapped ends and the convolutions thereof are adhesively secured together.

References Cited in the file of this patent

UNITED STATES PATENTS

2,930,614	McIntosh -----	Mar. 29, 1960
2,996,060	Appleby -----	Aug. 15, 1961