

(No Model.)

J. W. COYNE & J. A. SHANNON.
CHURN.

No. 526,561.

Patented Sept. 25, 1894.

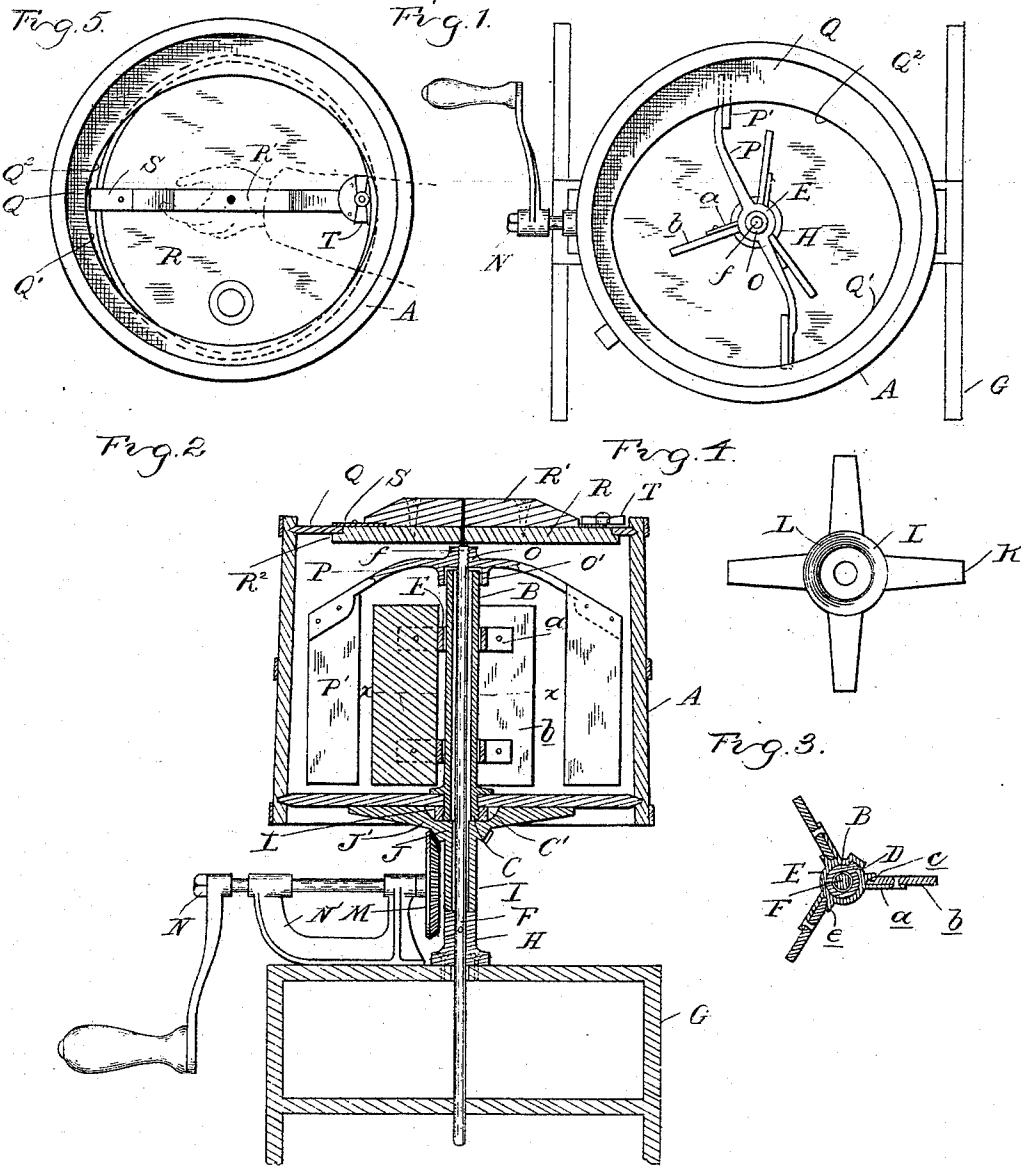

Witnesses
H. LeKobby
M. J. Pharty

By

Inventors
John W. Coyne
John A. Shannon
Wm. S. Maguire
Atty's.

UNITED STATES PATENT OFFICE.

JOHN W. COYNE, OF RIDGETOWN, AND JOHN A. SHANNON, OF DUTTON,
CANADA.

CHURN.

SPECIFICATION forming part of Letters Patent No. 526,561, dated September 25, 1894.

Application filed November 2, 1893. Serial No. 489,784. (No model.)

To all whom it may concern:

Be it known that we, JOHN W. COYNE, of Ridgetown, Kent county, and JOHN A. SHANNON, of Dutton, in the county of Elgin, Province of Ontario, Canada, both subjects of the Queen of Great Britain, have invented certain new and useful Improvements in Churns, of which the following is a specification, reference being had therein to the accompanying drawings.

The invention consists in the peculiar construction of the closure, and further in the peculiar construction, arrangement and combination of the various parts, all as more fully hereinafter described.

In the drawings, Figure 1 is a plan view of the churn with the cover removed. Fig. 2 is a vertical, central section thereof. Fig. 3 is a horizontal section on line *xx* Fig. 2. Fig. 4 is a plan view of the revolving tub support. Fig. 5 is a top plan of the tub with the cover, preparatory to securing it in place.

A is the churn body or casing, cylindrical in shape.

B is a tubular standard flanged near its lower end, which flange rests upon the upper side of the bottom of the tub and having a screw threaded nipple C passing through the bottom, the standard being secured in position by means of the clamping nut C'. This standard is provided on one side with a suitable rib or key D.

E are sleeves provided with a corresponding key way and adapted to fit over the standard B. These sleeves are provided with a series of flanges *a* to which are secured the radial dashers *b*, the ends of these dashers entering a socket *c* formed between the flanges *a* and lugs *e* on the sleeves.

F is a stationary shaft secured in the supporting frame G of the churn, preferably in the collar H at the top of said frame.

I is a collar sleeved about the shaft and resting on the collar H. This collar at its upper end is provided preferably by forming it integral therewith with a beveled pinion J, a central plate or hub J' and a series of supporting arms K, the whole forming the tub support. The hub J' is provided on its upper face with a tapering recess or bearing L in which the clamping nut C' is adapted to

fit, as plainly shown in Fig. 2 and thereby centering the sleeve or standard B about the shaft.

The tub is set upon the arms K and hubs J' with the shaft passing through the tubular standard B and is revolved by suitable drive mechanism, such as the bevel gear wheel M, meshing with the pinion J and secured to the crank shaft N, which is journaled in the bracket N' on the frame of the machine. The shaft F passes through the standard and is provided at its upper end with a screw threaded portion *f*.

O is a hub having a central screw-threaded aperture to engage the portion *f* of the shaft and serving when screwed thereon as a cap for the tubular standard B, the flange O' of the hub loosely embracing the standard. The hub is provided with radial arms P to which are secured the blades P'.

The cover or closure comprises a flat ring Q fitting tightly into the chine at the upper end of the tub or churn casing and provided with a central aperture Q' which is circular the greater part of its circumference, but at one side is provided with the eccentric portion Q². The cover R is of corresponding shape and is provided with a cross-bar R' having on its lower edge an inwardly extending flange R² adapted to project beneath the ring Q.

S is a plate or an extension of the cross-bar adapted to extend over the upper edge of the ring, as plainly shown in Fig. 2.

T is a locking button upon the upper face of the cover upon the opposite end of the cross-bar. To engage the cover in position the narrow portions of the cover are engaged in the wide portions of the opening as shown in Fig. 5, and then the cover is turned until it fits the aperture. The flange R² engaging beneath the ring and the plate S and button T engaging above, will clamp the cover in position. As all pressure is outward and as the centrifugal motion of the liquid tends to throw it outward to the sides it is evident that this form of cover will form a tight joint. The shape of the cover being as described gives us a maximum of opening through which the blades and dashers may be readily inserted and at the same time enables us to

lock the cover with its flange bearing against the under face of the ring Q. Motion being imparted to the crank shaft will turn the tub support upon which the tub stands and thereby rotate the tub and the central dashers b, the blades P' remaining stationary.

What we claim as our invention is—

1. In a churn, the combination of the casing of a rotary dasher therein, means for rotating the dasher, a flat ring fitting into the top of the casing having the eccentric inner portion Q², of the cover R, correspondingly shaped, said cover having the marginal flange R² on the lower edge thereof, and means for clamping this flange against the under face of the ring, substantially as described.

2. In a churn, the combination of the casing of a rotary dasher therein, means for rotating the dasher, a flat ring fitting into the top of the casing, having the eccentric inner portion Q², of the cover R correspondingly shaped, said cover having the marginal flange R² on the lower edge of the cover, the cross-

bar R', the extension S at one end, and the turn button T at the opposite end, substantially as described.

3. In a churn, the combination of the casing, a central tubular standard secured to the bottom and extending to near the top having a flange near its base resting on the bottom and a nipple extending through the base, a nut on the nipple below the base, of dashers secured to the standard, means for rotating the casing, stationary blades at the sides of the casing, a cap supported on the top of the standard to which said blades are secured, and a shaft extending through the standard, supporting the cap, substantially as described.

In testimony whereof we affix our signatures in presence of two witnesses.

JOHN W. COYNE.
JOHN A. SHANNON.

Witnesses:

M. B. O'DOHERTY,
JAMES WHITTEMORE.