



(72) MIYASHITA, TAKUYA, JP

(72) UKECHI, MITSUO, JP

(72) KAKU, RYOJI, JP

(71) JAPAN AVIATION ELECTRONICS INDUSTRY LIMITED, JP

(51) Int.Cl.⁶ G02B 6/122

(30) 1998/07/28 (212228/98) JP

(54) **DISPOSITIF DE GUIDE D'ONDES OPTIQUES ET METHODE DE FABRICATION DE CELUI-CI**

(54) **OPTICAL WAVEGUIDE DEVICE AND METHOD OF PRODUCING THE SAME**

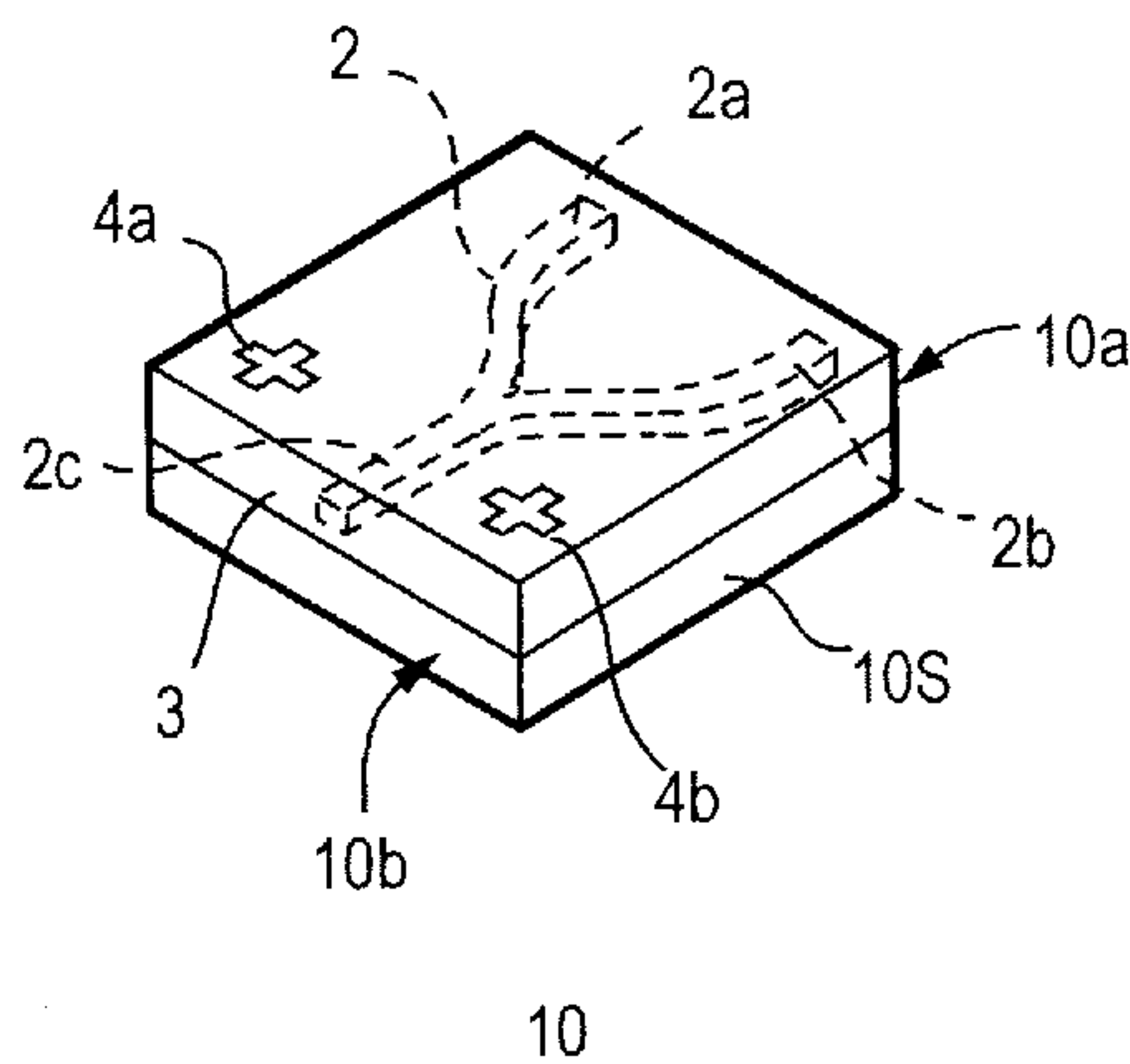

(57) An optical waveguide device is provided which comprises an optical waveguide chip (10) constructed by forming an optical waveguide (2) embedded in a clad layer (3) and alignment marks (4a, 4b) on the surface of a silicon single crystal board by the use of the etching technique and film forming technique; a device substrate (5) constructed by forming V grooves (5a, 5c) and alignment marks (4a', 4b') on the surface of a silicon single crystal board by the use of the etching technique and film forming technique, the optical waveguide chip and the device substrate being aligned with each other with reference to the respective alignment marks (4a, 4b) and (4a', 4b') and joined together; and optical fibers (8a, 8c) fitted and fixed in the V grooves (5a, 5c).

ABSTRACT

An optical waveguide device is provided which comprises an optical waveguide chip (10) constructed by forming an optical waveguide (2) embedded in a clad layer (3) and alignment marks (4a, 4b) on the surface of a silicon single crystal board by the use of the etching technique and film forming technique; a device substrate (5) constructed by forming V grooves (5a, 5c) and alignment marks (4a', 4b') on the surface of a silicon single crystal board by the use of the etching technique and film forming technique, the optical waveguide chip and the device substrate being aligned with each other with reference to the respective alignment marks (4a, 4b) and (4a', 4b') and joined together; and optical fibers (8a, 8c) fitted and fixed in the V grooves (5a, 5c).

OPTICAL WAVEGUIDE DEVICE AND METHOD OF PRODUCING THE SAME

BACKGROUND OF THE INVENTION

5 This invention relates to an optical waveguide device and a method of producing the same, and more particularly, to an optical waveguide device which allows for easily adjusting and aligning silicon substrates and an optical waveguide substrate with each other in their optimal relative positional relationship by passive
10 alignment and a method of producing the same.

 An example of the prior art will be described below with reference to Figs. 1A, 1B, 1C and 2.

 In Fig. 1A, formed on one side surface of a generally rectangular optical waveguide substrate 10S as cut out of a silicon
15 crystal, for example is a clad layer 3 in which a Y-shaped optical waveguide 2 is embedded. The branch passages 2a and 2b of the optical waveguide 2 terminate in end faces intersecting with one end surface of the optical waveguide substrate 10S while the branch passage 2c of the optical waveguide 2 terminates in an end face
20 intersecting with the opposite end surface of the optical waveguide substrate 10S.

 Referring to Fig. 1B, a generally rectangular V-grooved substrate 5A formed of silicon has formed in its surface 5As two grooves 5a, 5b (which will be referred to as V groove hereinafter)
25 having a V-shaped cross-section, the two grooves being parallel to each other and the side edges of the substrate 5A. On the other hand, another V-grooved substrate 5B shown in Fig. 1C has formed

in its surface 5Bs a single V groove 5c parallel to the side edges of the substrate 5B. It is a known practice to form V grooves 5a, 5b, 5c by etching in the surfaces of the substrates 5A, 5B cut out of a silicon single crystal. As shown in Fig. 2, optical fibers 8a, 8b and 5 8c are positioned and fixed in the respective V grooves 5a, 5b and 5c of the V-grooved substrates 5A and 5B such that their end faces are flush with or protrude slightly beyond the end faces 5Aa and 5Ba of the corresponding V-grooved substrates 5A and 5B. The center-to-center spacing between the two V grooves 5a and 5b is equal to that 10 between the outer ends of the two branch passages 2a and 2b of the Y-shaped optical waveguide 2.

As noted above, the optical waveguide substrate 10S having the optical waveguide 2 formed therein and the V-grooved substrates 5A and 5B having the optical fibers 8a, 8b and 8c fixed 15 thereto are separately manufactured, and then the V-grooved substrates 5A and 5B are translationally moved toward each other in the directions as indicated by the arrows in Fig. 2 by an alignment apparatus (not shown) such that the end faces of the optical fibers 8a, 8b and 8c are opposed to the end faces of the 20 respective optical branch passages 2a, 2b and 2c while the substrates 5A and 5B are both transversely and vertically adjusted so that the centers of the cores of optical fibers 8a, 8b and 8c are brought into alignment with the centers of the ends of the corresponding branch passages 2a, 2b and 2c of the optical 25 waveguide 2, whereafter the substrates are joined together as an integral unit. When joining the substrates together to form an integral unit, a ray of light is input into the optical fiber 8c fixed to

the left-side V-grooved substrate 5B. The three substrates are adjusted to their optimal relative positional relationship while monitoring the amount of the light as it is input through the optical waveguide 2 of the optical waveguide 2 into the two optical fibers 8a, 5 8b fixed to the right-side V-grooved substrate 5B, prior to joining the substrates together in alignment with each other. It is known as active alignment to adjust the substrates to their optimal relative positional relationship while monitoring the amount of the light transmitted. Such active alignment, however, does not 10 involve putting alignment marks on the optical waveguide substrate 10S and V-grooved substrates 5A, 5B to insure the exact relative positional relation.

An example of the conventional optical waveguide device is disclosed in Japanese Patent Publication 7-69497 for example. 15 This prior art example also requires that the optical waveguide substrate and the silicon substrates formed with V grooves for fixing optical fibers be separately made and that the substrates are adjusted to their optimal relative positional relationship prior to bonding and securing the substrates together. It should be noted 20 in this example, however, that alignment marks are put on the optical waveguide substrate while the corresponding reference marks are put on the silicon substrates to aid in adjusting the substrates to their optimal relative positional relationship. In adjusting the substrates to their optimal relative positional 25 relationship, it is known as passive alignment to adjust their relative positional relationship in a simple manner with the aid of alignment marks and reference marks without monitoring the

amount of the light transmitted.

As discussed above, the active alignment technique involving adjusting the substrates to their optimal relative positional relationship into alignment with each other while monitoring the amount of light transmitted is employed to assemble an optical waveguide device. While this method insures that the alignment process be accurately performed, it requires not only a complicated process of alignment to seek for the optimal position, but also a longer time to perform the process of alignment.

10

SUMMARY OF THE INVENTION

It is an object of this invention to provide an optical waveguide device which allows for easily adjusting and aligning device substrates and the optical waveguide substrate with each other in their optimal relative positional relationship by the use of the passive alignment technique rather than the active alignment technique and a method of producing the same.

15

An optical waveguide device according to this invention comprises a device substrate, an optical waveguide chip, and optical fibers,

20

the device substrate having a first region and a second region defined on the top surface thereof, the first and second regions being arranged in side-by-side juxtaposition from one end of the device substrate, the first region being formed with a V groove extending from the one end of the device substrate to a boundary between the first and second regions, and the second region having at least two first alignment marks formed at at least two spaced

25

apart locations on the second region;

the optical waveguide chip comprising an optical waveguide substrate having a first end surface and a second end surface, a clad layer formed over one side surface of the optical waveguide substrate and having one end edge flush with the first end surface of the optical waveguide substrate, an optical waveguide formed in the clad layer and extending from the one end edge to the other end edge of the clad layer, and at least two second alignment marks formed on the optical waveguide substrate at at least two locations spaced from each other and spaced from the optical waveguide substrate; and

the optical fiber being fitted and secured in the V groove and terminating in one end intersecting with the boundary between the first and second regions with the other end protruding from the device substrate;

wherein the optical waveguide chip is mounted on the device substrate such that the clad layer lies on the second region of the device substrate, the locations of the first and second alignment marks being defined such that superposing the first and second alignment marks one on the other will put one end face of the optical fiber into opposed alignment with one end of the optical waveguide.

BRIEF DESCRIPTION OF THE DRAWINGS

Fig. 1A is a perspective view of the substrate of the conventional optical waveguide device having optical waveguide formed therein;

Fig. 1B is a perspective view of the V-grooved substrate for mounting two optical fibers in the conventional optical waveguide device;

Fig. 1C is a perspective view of the V-grooved substrate for mounting one optical fiber in the conventional optical waveguide device;

Fig. 2 is a perspective illustration illustrating the process of assembling the three substrates shown in Figs. 1A, 1B and 1C;

Fig. 3A is a perspective view of an optical waveguide and the substrate forming an optical waveguide splitter according to this invention;

Fig. 3B is a perspective view of the device substrate composed of two V-grooved substrate sections and a mount substrate section in the foregoing embodiment;

Fig. 3C is a perspective view of an embodiment of the invention in the form of an optical waveguide splitter as assembled;

Fig. 4A is a sketch illustrating the first step of forming alignment marks for the optical waveguide and the substrate;

Fig. 4B is a sketch illustrating the second step of forming alignment marks for the optical waveguide and the substrate;

Fig. 4C is a sketch illustrating the third step of forming alignment marks for the optical waveguide and the substrate;

Fig. 4D is a sketch illustrating the fourth step of forming alignment marks for the optical waveguide and the substrate;

Fig. 4E is a sketch illustrating the fifth step of forming alignment marks for the optical waveguide and the substrate;

Fig. 4F is a sketch illustrating the sixth step of forming

alignment marks for the optical waveguide and the substrate;

Fig. 4G is a sketch illustrating the seventh step of forming alignment marks for the optical waveguide and the substrate;

Fig. 5A is a perspective view of an optical waveguide chip
5 forming an optical transmission/receiving module in another embodiment of the invention;

Fig. 5B is a perspective view of the device substrate in the embodiment of Fig. 5A;

Fig. 6 is a perspective view of an optical
10 transmission/receiving module formed by mounting the optical waveguide chip of Fig. 5A on the device substrate of Fig. 5B;

Fig. 7A is a perspective view of an optical waveguide chip constituting an optical transmission/receiving module in yet another embodiment of the invention;

Fig. 7B is a plan view of the optical waveguide chip shown in
15 Fig. 7A;

Fig. 7C is a perspective view of the device substrate in the embodiment of Fig. 7A; and

Fig. 8 is a perspective view of an optical
20 transmission/receiving module formed by assembling the optical waveguide chip of Fig. 7A and the device substrate of Fig. 7C.

DETAILED DESCRIPTION OF THE PREFERRED EMBODIMENTS

25 An embodiment of the invention be will be described below with reference to Figs. 3A, 3B and 3C. Figs. 3A and 3B are exploded perspective views of an optical waveguide splitter in the

form of an optical waveguide device with optical fibers removed while Fig. 3C is a perspective view of the optical waveguide splitter assembled with optical fibers.

As shown in Fig. 3A, a clad layer 3 and a Y-shaped optical
5 waveguide 2 including branch passages 2a, 2b and 2c therein are formed by the known etching technique and film forming technique on the surface of a generally rectangular optical waveguide substrate 10S cut out of a silicon single crystal to constitute an optical waveguide chip 10. Additionally, alignment marks 4a, 4b
10 are formed on or in the clad layer 3 on the opposite sides of the branch passage 2a toward the end surface 10b of the substrate 10S. The end faces of the branch passages 2a, 2b lie in one end surface 10a of the substrate 10S while the end face of the branch passage 2c lies in the end surface 10b of the substrate 10S opposite from the
15 one end surface.

As shown in Fig. 3B, a generally rectangular device substrate
5 cut out of a silicon single crystal is formed with two spaced apart dicing grooves 5d, 5e extending perpendicularly to the length of the device substrate 5 so as to divide the surface thereof into three
20 regions to thereby define two V-grooved substrate sections 5A, 5B separated by a mount substrate section 5C. It is thus to be appreciated that the top surfaces (three regions) of the substrate sections 5A, 5B and 5C lie in the same plane which will hereinafter be defined as a reference plane 5s. The dicing grooves 5d, 5e are
25 preliminarily formed to insure that the V grooves 5a, 5b and 5c which will be subsequently formed by etching will have no insufficiently etched shallow portions adjacent their inner ends.

Two grooves 5a, 5b (V grooves) having a V-shaped cross-section and one V groove 5c are formed on the surfaces of the V-grooved substrate sections 5A and 5B, respectively by the known etching technique so as to extend from the opposite longitudinal ends of the device substrate 5 perpendicularly into communication with the dicing grooves 5d and 5e. In addition, alignment marks 4a', 4b' are formed on the surface of the mount substrate section 5C.

Then, the optical waveguide chip 10 is turned upside down and placed on the mount substrate section 5C. The optical waveguide chip 10 is precisely positioned relative to the V-grooved substrate sections 5A, 5B such that the alignment marks 4a', 4b' on the mount substrate section 5C are superposed in registration on the corresponding alignment marks 4a, 4b on the optical waveguide substrate 10S, followed by bonding the optical waveguide chip to the waveguide substrate 10S. Subsequently, optical fibers 8a, 8b and 8c are attached to the corresponding V grooves 5a, 5b and 5c such that the end faces of the fibers are opposed to the end faces of the respective optical branch passages 2a, 2b and 2c comprising the optical waveguide 2 to construct an optical waveguide device as shown in Fig. 3C. It is to be understood that this allows for constructing an optical waveguide device in which the center of the optical fibers 8 is in accurate alignment with the center of the optical waveguide 2.

The positional relationship between the centers of the optical branch passages 2a, 2b, 2c and the alignment marks 4a, 4b is preliminarily set with high precision, and the positional relationship between the centers of the alignment marks 4a', 4b'

and the V grooves 5a, 5b and 5c is preliminarily set with high precision to insure accurate alignment between the centers of the ends of the optical branch passages 2a, 2b, 2c and the centers of the optical fibers 8a, 8b and 8c fixed to the V grooves 5a, 5b and 5c.

5 The optical fibers have a uniform diameter while the V grooves have a uniform opening angle, so that the height of the center of each optical fiber above the substrate reference plane 5s can be set at any height between a positive value less than the radius of the optical fiber and a negative value.

10 The sequential steps of manufacturing the optical waveguide chip 10 will now be described with reference to Figs. 4A-4G.

In the step shown in Fig. 4A, an under-clad layer 31 is formed on the surface of an optical waveguide substrate 10S cut out of a silicon single crystal. Polyimide may be used as an example of the material of which the under-clad layer 31 may be formed. The polyimide layer may be prepared by mixing a plurality of kinds of polyimide solutions in appropriate proportions and applying the mixture to the substrate prior to calcining it. While the thickness of the under-clad layer 31 is exaggerated for purposes of illustration, actually it is extremely thin such as on the order of 15 μm together with an over-clad layer 31' which will be described later. Metallic films 32 which are subsequently to be alignment marks 4 are formed on the surface of the under-clad layer 31 at predetermined positions. Titanium or CrAu may be used by way of example for the material of which the metallic films 32 may be formed.

25 In Fig. 4B, a layer 23 of polymeric material which is subsequently to be an optical waveguide 2 is formed on the entire

surface of the under-clad layer 31 containing the metallic films 32. While specifically the polymeric material layer 23 may also be formed from polyimide, it is of such composition that it will exhibit a refractive index higher than that of the under-clad layer 31 and the thickness of the layer may be on the order of 7 μm by way of example. A pattern 2', 4a", 4b" for the optical waveguide 2 and the alignment marks 4a, 4b is formed on the surface of the polymeric material layer 23.

In the step of Fig. 4C, the polymeric material layer 23 is removed by the reactive ion etching technique (RIE). The reactive ion etching RIE does not act on the metallic films 32.

The step shown in Fig. 4D is to remove the remaining pattern 2' and 4a", 4b" which are metallic films and those portions of the metallic films 32 which are exposed, whereby the optical waveguide 2 and the alignment marks 4a, 4b both made of polymeric material are produced.

In the step of Fig. 4E, an over-clad layer 31' is formed over the entire surface of the under-clad layer 31 containing the patterns formed. The material for the over-clad layer 31' is of the same composition as the material of which the under-clad layer 31 is formed, such as polyimide. The over-clad layer 31' may be prepared by mixing a plurality of kinds of polyimide solutions in appropriate proportions and applying the mixture to the surface followed by calcining it. The over-clad layer 31' together with the under-clad layer 31 forms a clad layer 3 which surrounds the optical waveguide 2 and which has a refractive index lower than that of the optical waveguide 2.

In the further step shown in Fig. 4F, a Y-shaped pattern of metallic film 33 is formed to cover the optical waveguide 2 (optical branch passages 2a, 2b, 2c) on the over-clad layer 31'.

In the step of Fig. 4G, those portions of the over-clad layer 31' other than those portions underlying the metallic film 33, and the under-clad layer 31 and those portions of the polymeric material layer 23 over the alignment marks 4a, 4b are removed by RIE to expose the surfaces of the alignment marks and the optical waveguide substrate 10S. The over-clad layer 31' remaining underneath the metallic film 33 and the under-clad layer 31 correspond to the clad layer 3.

While the metallic film 33 is illustrated as remaining in Fig. 4G, it may be and usually is removed. In addition while in the example of Figs. 4A-4G the pattern of the over-clad layer 31' is illustrated as being in the shape of Y so as to conform with the Y-shaped optical waveguide 2, the over-clad layer 31' may remain as formed over the entire surface of the substrate 10S as shown in Fig. 3A. In that case, the steps of Figs. 4F and 4G are omitted.

As can be appreciated from the foregoing, the relative positional relationship between the optical waveguide 2 and the alignment marks 4a, 4b may be accurately defined by forming the optical waveguide 2 and the alignment marks 4a, 4b in a single masking pattern (pattern 2', 4a'', 4b'' in Figs. 4B and 4C). A high precision alignment can thus be realized. In consideration of the requirement that the alignment marks 4 which are metallic films be neither vaporized nor oxidized when forming the layer 23 which will be an optical waveguide 2, the material of which the layer 23 is

formed may preferably be a polymeric material which can be worked on at a low processing temperature below 400 °C. In this regard, it should be noted that if an attempt is made to form an optical waveguide from quartz by flame deposition process, such
5 waveguide could not be allowed to remain normally on the under-clad layer 31 because the processing temperature of quartz exceeds 1000 °C. It is a matter of course that the material of which the under-clad layer 31 is formed would also be burned out at such a high processing temperature as 1000 °C.

10 Referring to Figs. 5A, 5B and Fig. 6, an optical transmission/receiving module in another embodiment of the optical waveguide device according to this invention will be described below.

First with reference to Fig. 5A, in this embodiment a clad
15 layer 3 is formed on an optical waveguide substrate 10S which is greater both in width and length than the clad layer with one end surface of the clad layer flush with one end surface of the substrate 10S such that marginal areas are left on the substrate on the other opposite end and on the opposite sides of the clad layer 3. An end
20 face of the optical branch passage 2a lies in the middle of the end surface of the clad layer 3 flush with the one end surface of the optical waveguide substrate 10S while the end faces of the branch passages 2a, 2b lie in the opposite end surface of the clad layer. In this embodiment, a laser diode 9 and a photo diode 15 are disposed
25 in opposition to the end faces of the branch passages 2a and 2b, respectively with their one electrodes placed on electrodes 11a and 11b, respectively formed on substrate 10S. Alignment marks 4a,

4b, 4c and 4d are formed on the substrate 10S at four corners of an area surrounding the arrangement of the clad layer 3, laser diode 9 and photo diode 15. Further formed on the substrate 10S outside of the alignment marks 4c and 4d are electrodes 11c and 11d which
5 are wire-bonded to the other terminals of the laser diode 9 and photo diode 15, respectively.

Each of the electrodes 11a and 11b is in the shape of H comprising two lands interconnected by a bridge with one of the lands positioned inside of an imaginary extension of the
10 corresponding one of the opposite side edges of the clad layer 3 while the other land is positioned outside of an imaginary extension of the corresponding one of the opposite side edges of the clad layer 3. Placed on and connected with the inner lands of the electrodes 11a and 11b are the laser diode 9 and photo diode 15. The lands of
15 the electrodes 11c and 11d are positioned outside of the imaginary extensions of the opposite side edges of the clad layer 3 and have leads extending therefrom toward inside of the imaginary extensions. It can thus be appreciated that the positional relationship between the various parts attached and formed on the
20 optical waveguide substrate 10S and the alignment marks 4a-4b may be accurately set and defined.

Next referring to Fig. 5B, a generally rectangular substrate 5, which is greater both in width and length than the optical waveguide substrate 10S, is formed in its top surface with a dicing
25 groove 5e extending transversely of the length of the substrate 5 so as to divide the length thereof into two sections to thereby define a mount substrate section 5C and a V-grooved substrate section 5B.

-15-

As in the case of Fig. 3B, the V-grooved substrate section 5B has formed therein a V groove 5c extending from the center of the end face thereof into communication with the dicing groove 5e. The mount substrate section 5C has formed in its top surface a recess 12
5 extending from the end face of the section opposite from the dicing groove 5e into communication with the dicing groove 5e so as to leave banks 5Ca, 5Cb on the opposite sides of the recess. The width of the recess 12 is sized to accommodate the clad layer 3. Formed on the top surfaces of the banks 5Ca, 5Cb are alignment
10 marks 4a', 4b', 4c' and 4d' in correspondence with the alignment marks 4a, 4b, 4c and 4d shown in Fig. 5A. Further formed on the top surfaces of the banks 5Ca, 5Cb are H-shaped electrodes 11a', 11b', 11c' and 11d' having inner lands which will underlie the substrate 10S and outer lands which will be positioned outside of
15 the substrate. The inner lands have solder bumps 13 formed thereon. In assembly, the clad layer 3 and the laser diode 9 and photo diode 15 protruding from the surface of the optical waveguide substrate 10S are all accommodated in the recess 12.

After the laser diode 9 and photo diode 15 have been
20 mounted on the optical waveguide substrate 10S as described above with reference to Fig. 5A, the resulting optical waveguide chip 10 is turned upside down and placed in position on the mount substrate section 5C described in Fig. 5B with reference to the alignment marks 4a'- 4d' to form an assembly as shown in Fig. 6. Then, the
25 entire assembly is heated while the substrate 10S is pressed against the mount substrate section 5C to bond them together by means of the solder bumps 13. Further, gaps (recess 12) between

the optical waveguide chip 10 and the mount substrate section 5C is filled with resin to protect the mounted laser diode 9 and photo diode 15.

Referring now to Figs. 7A, 7B, 7C and Fig. 8, an optical transmission/receiving module in still another embodiment of the optical waveguide device according to this invention will be described below.

In the art of optical communication, plans are now afoot to provide both bi-directional digital communications via signal light with a wavelength of $1.31\ \mu\text{m}$ and analog picture broadcasting via signal light with a wavelength of $1.55\ \mu\text{m}$ in a single optical fiber. In this instance, a terminal equipment designed to utilize such signal lights would need a bi-directional communication module capable of separating the signal lights of two wavelengths of $1.31\ \mu\text{m}$ and $1.55\ \mu\text{m}$ through a filter prior to introducing the signal light of $1.31\ \mu\text{m}$ into both of the laser diode 9 and photo diode 15 while introducing the signal light of $1.55\ \mu\text{m}$ into a picture receiver (not shown).

In the embodiment of Figs. 7A, 7B, 7C and Fig. 8, a single silicon substrate 5 is divided into three regions, a central mount substrate section 5C and two V-grooved substrate sections 5A, 5B on the opposite sides of the mount substrate section 5C as in the embodiment of Figs. 3A, 3B, 3C. The mount substrate section 5C has formed by etching in its top surface a recess 12 extending from the dicing groove 5d into communication with the dicing groove 5e so as to define banks 5Ca, 5Cb on the opposite sides of the recess like the embodiment of Fig. 5B. The V-grooved substrate section

-17-

5A is formed with a V groove 5a and may have formed on the top surface thereof electrodes 11a, 11b on which optical-electronic elements (such as laser diode 9 and photo diode 15) may be mounted.

5 Now with reference to Fig. 7A, a clad layer 3 having an optical waveguide 2 embedded therein is formed on an optical waveguide substrate 10S. The optical waveguide 2 in this embodiment comprises a straight optical waveguide path 2D for transmitting signal light of a wavelength of 1.31 μm and signal
10 light of a wavelength of 1.55 μm and optical branch passages 2a, 2b, 2c constituting a Y-branched optical waveguide path 2Y for transmitting signal light of a wavelength of 1.31 μm . The ends of the straight optical waveguide path 2D and the optical branch
15 passage 2c are coupled together, the coupled end face lying in the end surface 10b of the clad layer 3. Formed on the end surface 10b of the clad layer 3 over the coupled end face is a dielectric multi-layer film filter 14 allowing the passage of the signal light of a wavelength of 1.31 μm but reflecting the signal light of a
20 wavelength of 1.55 μm . It is seen in Fig. 7B which is a top plan view of the optical waveguide chip 10 that the end surface 10b of the clad layer 3 with which the coupled end face intersect is not at right angles but at an angle with respect to the straight optical
25 waveguide path 2D so that the reflected light at the dielectric multi-layer film filter 14 may be introduced into the optical branch passage 2c. More specifically, the angle is chosen such that a line bisecting the angle defined at the coupled end between the straight optical waveguide path 2D and the optical branch passage 2c makes

-18-

a right angle with the plane of the end surface 10b of the clad layer 3. The optical waveguide 2 and the alignment marks 4a, 4b may be formed by the same method as that described with reference to Figs. 4A-4G. It is to be noted that the fact that the optical
5 waveguide 2 is formed on the optical waveguide substrate 10S separate from the device substrate 5 is a favorable factor in forming the dielectric multi-layer film filter 14 the end surface of the optical waveguide 2 and actually facilitates the formation of the filter.

Referring to Fig. 7C, the V-grooved substrate section 5A of
10 the device substrate 5 is formed with a V groove 5a for receiving and securing an optical fiber 8a intersecting at right angles with the dicing groove 5d, and has formed on the top surface thereof electrodes 11a and 11b with which a photo diode 15 (Fig. 8) and a
15 laser diode 9 (Fig. 8) may be connected. The direction of extension of the dicing groove 5e is angled at $\Phi/2$ with respect to a direction perpendicular to the direction of extension of the V groove 5a such that the direction of extension of the groove 5e will coincide with the plane of the end surface 10b of the optical waveguide substrate 10S when the optical waveguide chip 10 is turned upside down and
20 placed on the mount substrate section 5C. The V groove 5c is formed in the V-grooved substrate section 5B to extend such that it will coincide with the direction of extension of the V groove 5a.

The optical waveguide chip 10 shown in Fig. 7A is turned upside down and placed in position on the mount substrate section
25 5C shown in Fig. 7C with the waveguide chip and the mount substrate section being aligned with each other by superposing the alignment marks 4a, 4b on the optical waveguide chip 10 over the

alignment marks 4a', 4b' on the mount substrate section 5C, followed by bonding the optical waveguide chip 10 and the substrate 5 together to form an integral assembly. In addition, optical fibers 8a and 8c are fitted and fixed in the V grooves 5a and 5b, respectively to form an optical transmission/receiving module as shown in Fig. 8.

In order to register the alignment marks 4a, 4b formed on the optical waveguide chip 10 and the alignment marks 4a', 4b' formed on the mount substrate section 5C while recognizing one against the other, a camera may be inserted between the opposed substrates to perform the alignment procedures while simultaneously observing the patterns of the opposed alignment marks. Alternatively, light having a high penetrating power such as infrared rays or X rays may be used to irradiate the alignment marks on the substrates so that the alignment process may be carried out by observing the transmitted light. The optical waveguide substrate 10S and the device substrate 5, which have actually extremely thin thickness on the order of 500 μm , permits easy transmission of infrared rays or X rays to allow the operator to fluoroscope the alignment marks. The positioning and alignment process as described above not only is very simple and easy but also requires only a short period time.

In the optical transmission/receiving module the assembly of which has been completed, the optical fibers 8a and 8c have their central axes in opposition to the centers of the end faces of the straight optical waveguide path 2D while the laser diode 9 and photo diode 15 are in opposition to the centers of the end faces of the

respective branch passages of the Y-branched optical waveguide path 2Y.

With the construction as described above in connection with Figs. 7 and 8, signal light LS3 of a wavelength of 1.55 μm introduced through the optical fiber 8a on one side is passed into the straight optical waveguide path 2D, penetrates through the dielectric multi-layer film filter 14 and is output to the optical fiber 8c on the other side. In contrast, signal light LS1 of a wavelength of 1.31 μm introduced through the optical fiber 8a on one side is passed into the straight optical waveguide path 2D and reflected at the dielectric multi-layer film filter 14 to be introduced into the Y-branched optical waveguide path 2Y and is received by the photo diode 15 positioned in opposition to the end face of the optical branch passage 2a. Signal light LS2 of a wavelength of 1.31 μm transmitted from the laser diode 9 is introduced into the optical branch passage 2c through the end face of the optical branch passage 2b opposing the laser diode 9, is reflected at the dielectric multi-layer film filter 14 to be introduced into the straight optical waveguide path 2D and is then output to the optical fiber 8a on the one side. It will thus be appreciated that this invention allows for both providing bi-directional digital communications via signal light of a wavelength of 1.31 μm and by passing signal light of a wavelength of 1.55 μm in a single optical fiber.

25 EFFECTS OF THE INVENTION

From the foregoing description, it can be seen that this invention involves forming on a substrate of raw material an optical

waveguide embedded in a clad layer and alignment marks by utilization of etching and film forming techniques to constitute an optical waveguide chip, forming on a substrate of raw material V grooves and alignment marks by utilization of etching and film forming techniques to constitute a device substrate, whereby positioning and securing of the optical waveguide chip and the device substrate relative to each other may be effected easily and accurately by referring to the alignment marks on the chip and the substrate. In spite of the fact that the alignment operation according to this invention is based on the so-called passive alignment technique, the accuracy in positioning and alignment is comparable to that obtainable by the active alignment technique, and yet the positioning and aligning process of this invention not only is simple and easy, but also requires only a short period time.

WHAT IS CLAIMED IS:

1. An optical waveguide device comprising,
a device substrate having a first region and a second region defined on the top surface thereof, said first and second regions being arranged in side-by-side juxtaposition from one end of said device substrate, said first region being formed with a V groove extending from said one end of said device substrate to a boundary between said first and second regions, and said second region having at least two first alignment marks formed at at least two spaced apart locations on the second region;

an optical waveguide chip comprising an optical waveguide substrate having a first end surface and a second end surface, a clad layer formed over one side surface of said optical waveguide substrate and having one end edge flush with the first end surface of the optical waveguide substrate, an optical waveguide formed in said clad layer and extending from said one end edge to the other end edge of the clad layer, and at least two second alignment marks formed on said optical waveguide substrate at at least two locations spaced from each other and spaced from said optical waveguide substrate; and

an optical fiber fitted and secured in said V groove and terminating in one end intersecting with said boundary between said first and second regions with the other end protruding from said device substrate;

wherein said optical waveguide chip is mounted on said device substrate such that said clad layer lies on the second region of said device substrate, the locations of said first and second

alignment marks being defined such that superposing the first and second alignment marks one on the other will put one end face of said optical fiber into opposed alignment with one end of said optical waveguide.

2. The optical waveguide device of claim 1, wherein said optical waveguide includes a Y-branched optical waveguide path comprising one optical branch passage terminating in an end intersecting with said one end edge of the clad layer and two optical branch passages terminating in an end intersecting with said other end edge of the clad layer.

3. The optical waveguide device of claim 1, wherein said optical waveguide includes a first optical waveguide path and a second optical waveguide path extending from said one end edge toward said other end edge of the clad layer, said first and second optical waveguide paths being coupled together at said one end edge of the clad layer into a coupled end which constitutes said one end of said optical waveguide, said first and second optical waveguide paths having other ends spaced apart from each other and intersecting with said other end edge of the clad layer, and further including a dielectric multi-layer film filter formed on the one end edge of the clad layer so as to cover said coupled end, said dielectric multi-layer film filter allowing passage of light of a first wavelength but reflecting light of a second wavelength, said one end edge of the clad layer being at right angle to a line bisecting an angle defined at the coupled end between said first and second optical waveguide

paths.

4. The optical waveguide device of claim 1, 2 or 3, wherein said one end edge of the clad layer is located to extend along the boundary between said first and second regions, said device substrate having formed in its surface a dicing groove extending along said boundary.

5. The optical waveguide device of claim 2, wherein said device substrate has a third region adjoining said second region on the side opposite from said first region, said third region having formed in its surface two V grooves extending from the end edge of said device substrate opposite from said second region to a boundary between said second and third regions, and including two optical fibers having their end portions fitted and secured in said two V grooves with end faces of said two optical fibers in opposition to the spaced apart ends of said branch passages at said other end edge of the clad layer.

6. The optical waveguide device of claim 2, wherein said device substrate has a third region adjoining said second region on the side opposite from said first region, said third region having mounted thereon a light emitting element and a light receiving element in opposition to the spaced apart ends of said branch passages positioned at said other end edge of the clad layer.

7. The optical waveguide device of claim 5 or 6, wherein

said device substrate has formed in its surface another dicing groove extending along a boundary between said second and third regions.

8. The optical waveguide device of claim 2, wherein said clad layer is formed so as to leave marginal areas on said optical waveguide substrate on the second end surface, and including a light emitting element and a light receiving element mounted on said marginal areas on said optical waveguide substrate in opposition to the spaced apart ends of said branch passages of said Y-branched optical waveguide path positioned at said other end edge of the clad layer.

9. The optical waveguide device of claim 1, wherein said optical waveguide includes a straight optical waveguide path extending generally linearly from said one end edge to said other end edge of the clad layer, a Y-branched optical waveguide path having as branch passages two arms and one leg, said one leg terminating in one end intersecting with said one end edge of the clad layer, said two arms terminating in one ends intersecting with said other end edge of the clad layer, one end of said straight optical waveguide path and said leg end of said Y-branched optical waveguide path being coupled together edge of the clad layer into a coupled end so as to define an included angle therebetween of less than 90° , said one end edge of the clad layer being approximately at right angles to a lined bisecting said angle, and further including a dielectric multi-layer film filter formed on the one end edge of the

clad layer so as to cover the end face of said coupled end, said dielectric multi-layer film filter allowing passage of light of a first wavelength but reflecting light of a second wavelength.

10. The optical waveguide device of claim 9, further including a light emitting element positioned and fixed on the surface of said optical waveguide substrate in opposition to the end face of one of the two arms of said Y-branched optical waveguide path.

11. The optical waveguide device of claim 10, further including a light receiving element positioned and fixed on the surface of said optical waveguide substrate in opposition to the end face of the other of the two arms of said Y-branched optical waveguide path.

12. The optical waveguide device of claim 9, 10 or 11, wherein said device substrate has a third region adjoining said second region on the side opposite from said first region, said third region having formed in its surface another V groove extending from the end edge of the device substrate opposite from said second region to a boundary between said second and third regions, and including another optical fiber having its end portions fitted and secured in said another V groove with an end face of said another optical fiber in opposition to the other end of said straight optical waveguide path.

13. The optical waveguide device of any one of claims 1, 2, 3, 5, 6, 8, 9, 10 and 11, wherein said optical waveguide is formed of polymeric material.

14. The optical waveguide device of any one of claims 1, 2, 3, 5, 6, 8, 9, 10 and 11, wherein at least two of said alignment marks are formed in spaced relation to each other on each of the surfaces of said optical waveguide substrate and said device substrate.

15. The optical waveguide device of any one of claims 1, 2, 3, 5, 6, 8, 9, 10 and 11, wherein said optical waveguide substrate and said device substrate each comprise a board of silicon single crystal.

16. The optical waveguide device of any one of claims 1, 2, 3, 5, 6, 8, 9, 10 and 11, further including metallic film lands formed on a plurality of opposed positions on the opposed surfaces of said optical waveguide substrate and said device substrate, and solder bumps formed on said metallic film lands for bonding the opposed metallic film lands.

17. The optical waveguide device of any one of claims 1, 2, 3, 5, 6, 8, 9, 10 and 11, wherein gaps between said optical waveguide substrate and said device substrate are filled with resin.

18. A method of producing an optical waveguide device, comprising the steps of:

- (a) forming an under-clad layer on an optical waveguide

substrate composed of a silicon single crystal board;

(b) forming an alignment mark-forming metallic film on a predetermined location on a surface of said under-clad layer;

(c) forming an optical waveguide-forming polymeric material layer on the entire surface of said under-clad layer containing said alignment mark-forming metallic film;

(d) forming an optical waveguide-forming pattern and an alignment mark-forming pattern on a surface of said optical waveguide-forming polymeric material layer

(e) removing said optical waveguide-forming polymeric material layer by reactive ion etching technique;

(f) removing those portion of said optical waveguide-forming pattern, an alignment mark-forming pattern and said alignment mark-forming metallic film; and

(g) forming an over-clad layer on the entire surface of said under-clad layer to thereby construct an optical waveguide chip; and

(h) disposing said optical waveguide chip on a device substrate having a V groove and alignment marks formed on the surface thereof, with said clad layer side of the chip facing the device substrate;

(i) bonding said optical waveguide chip and said device substrate together with the alignment marks on said optical waveguide substrate in superposed registration with the alignment marks on said device substrate; and

(j) fitting and securing an end portion of an optical fiber in said V groove.

19. The method of claim 18, wherein said step (g) further including the steps of:

- (g-1) forming a protective metallic film on that area of the surface of said over-clad layer covering said optical waveguide; and
- (g-2) removing said over-clad layer except that area thereof underlying said protective metallic film by reactive ion etching technique to thereby expose said alignment marks and the surface of said optical waveguide substrate.

20. The method of claim 18 or 19, further including the following steps of producing device substrate:

- (u) forming a dicing groove transversely in the surface of said device substrate which has been cut out of a silicon single crystal board to define a first region and an adjoining second region separated by said dicing groove;
- (v) forming a V groove extending from one end of said device substrate longitudinally through said first region into said dicing groove;
- (w) forming alignment marks on said second region;
- (x) disposing said optical waveguide chip on said second region of said device substrate, with said optical waveguide substrate facing outside;
- (y) aligning the alignment marks on said optical waveguide substrate in superposed registration with the alignment marks on said device substrate prior to bonding said optical waveguide chip and said device substrate together; and

-30-

(z) fitting and securing an end portion of an optical fiber in said V groove with an end face of the optical fiber facing the end face of said optical waveguide.

FIG. 1A PRIOR ART

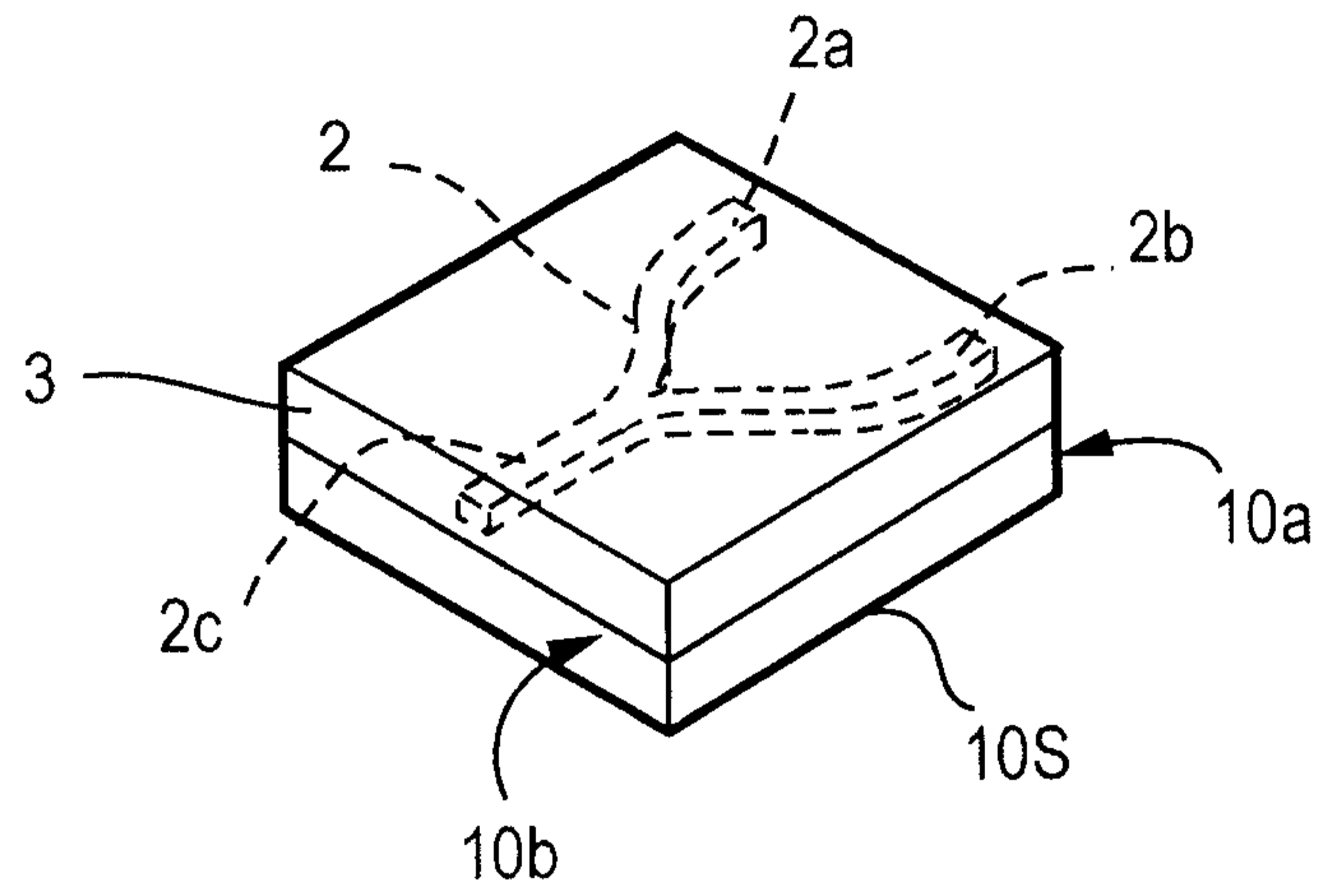

FIG. 1B PRIOR ART

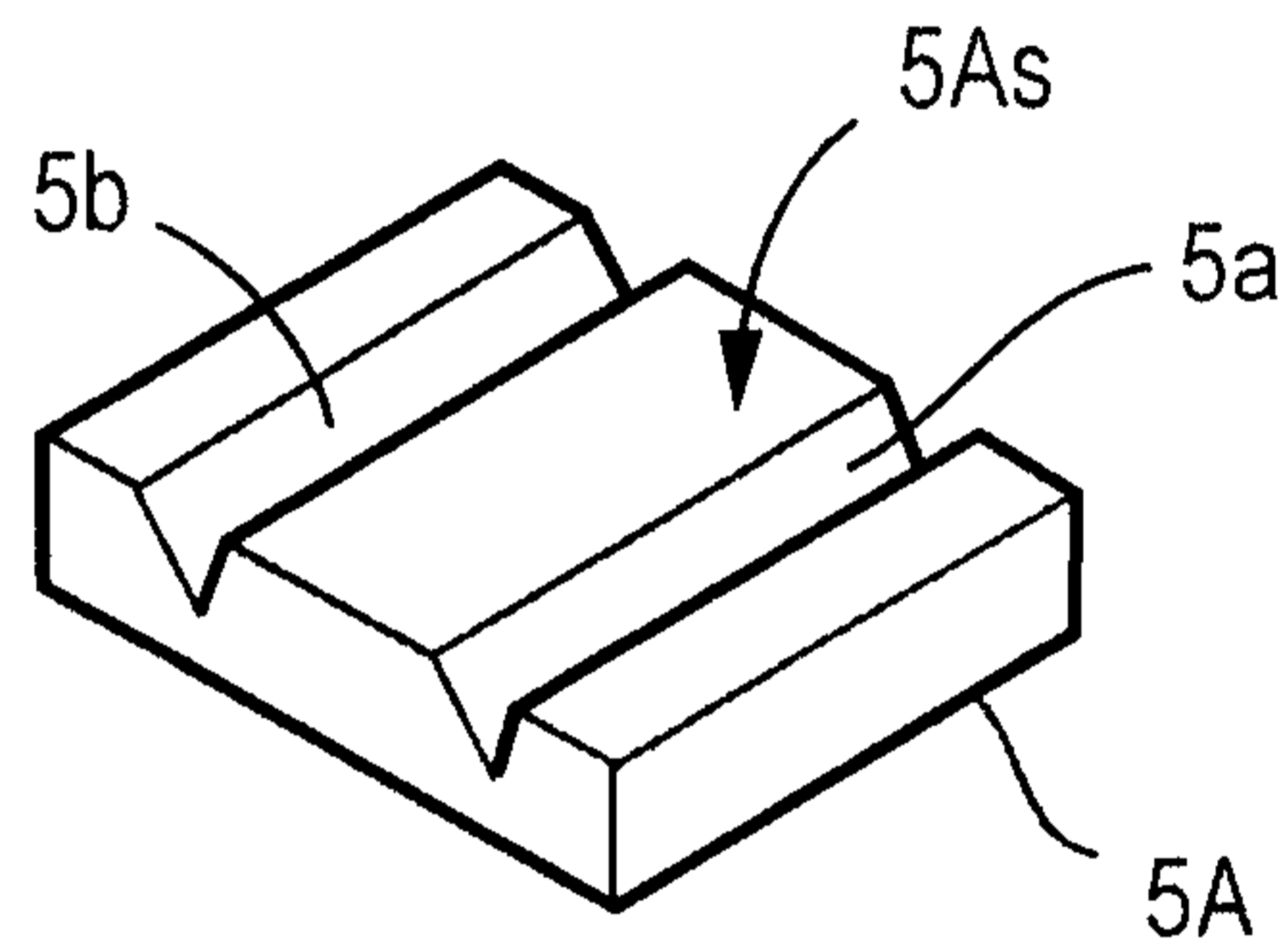

FIG. 1C PRIOR ART

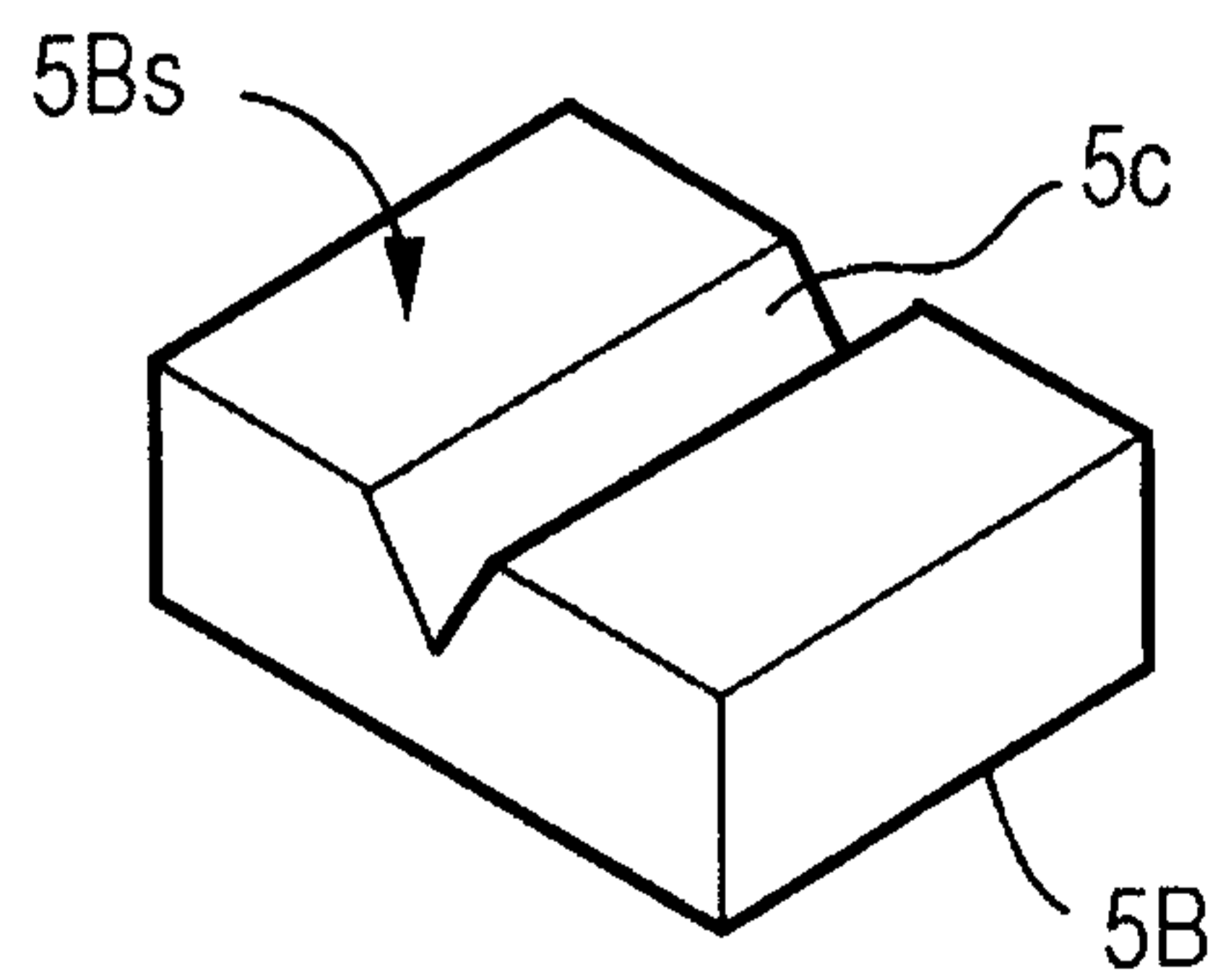

FIG. 2 PRIOR ART

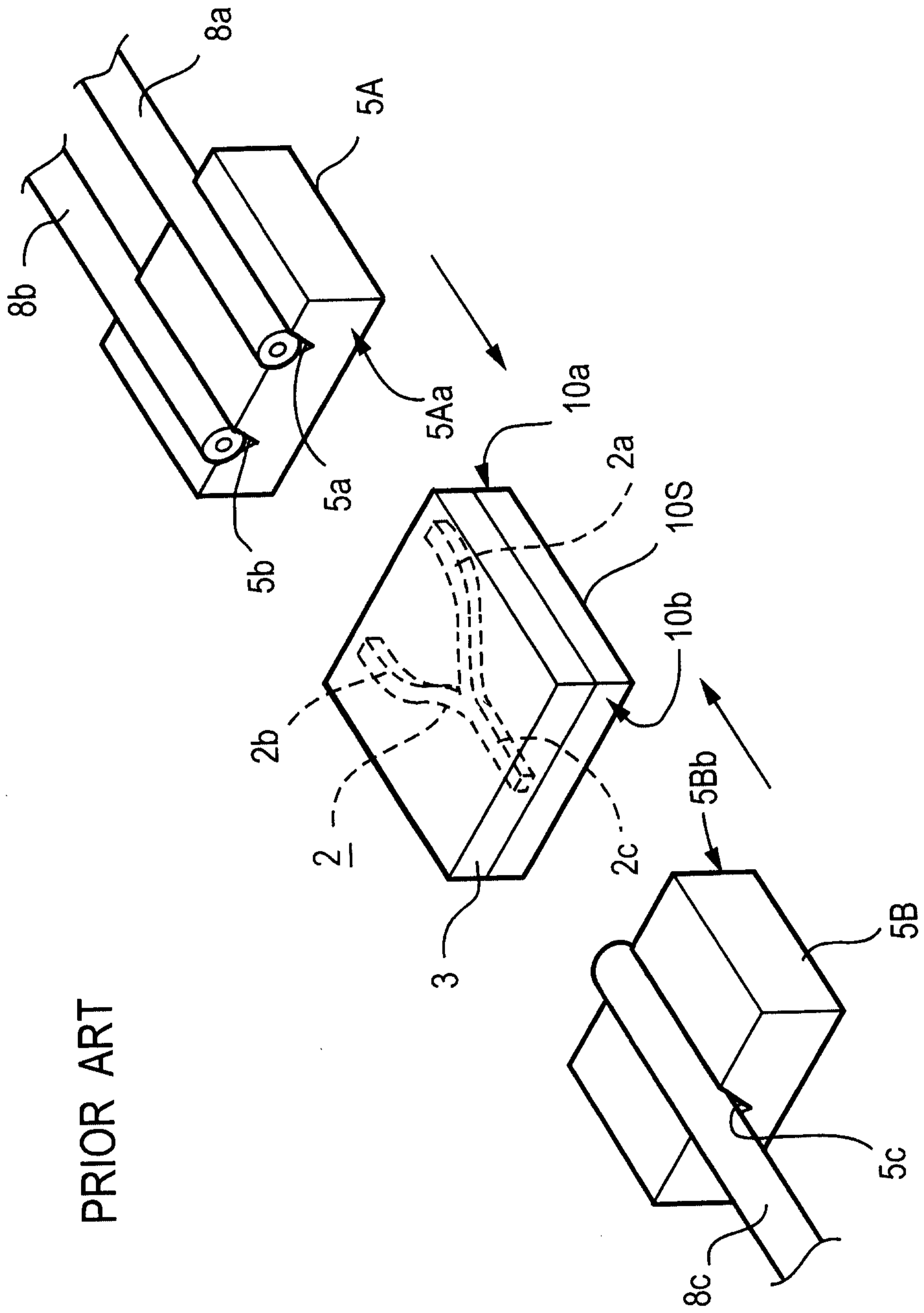

FIG. 3B

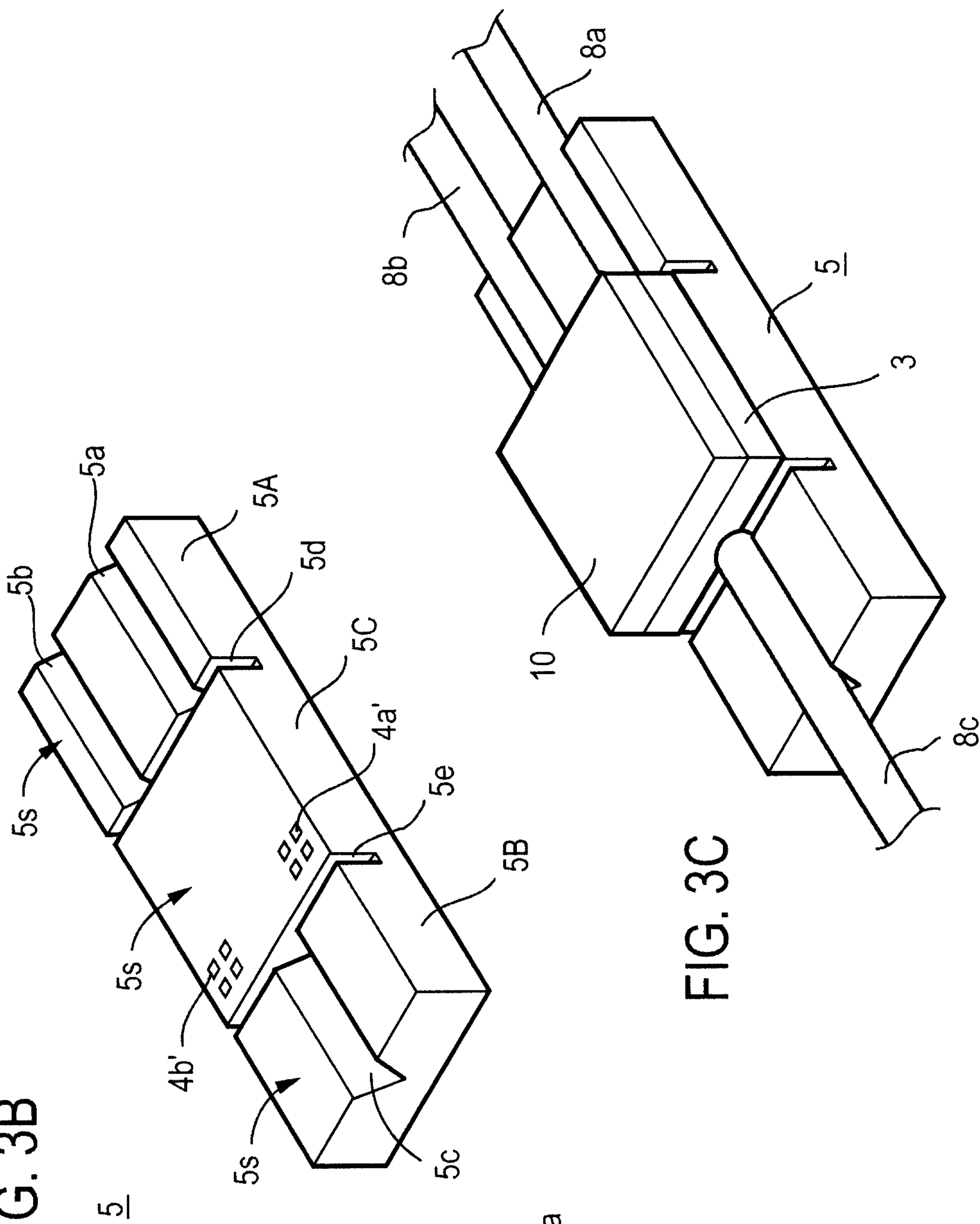

FIG. 3A

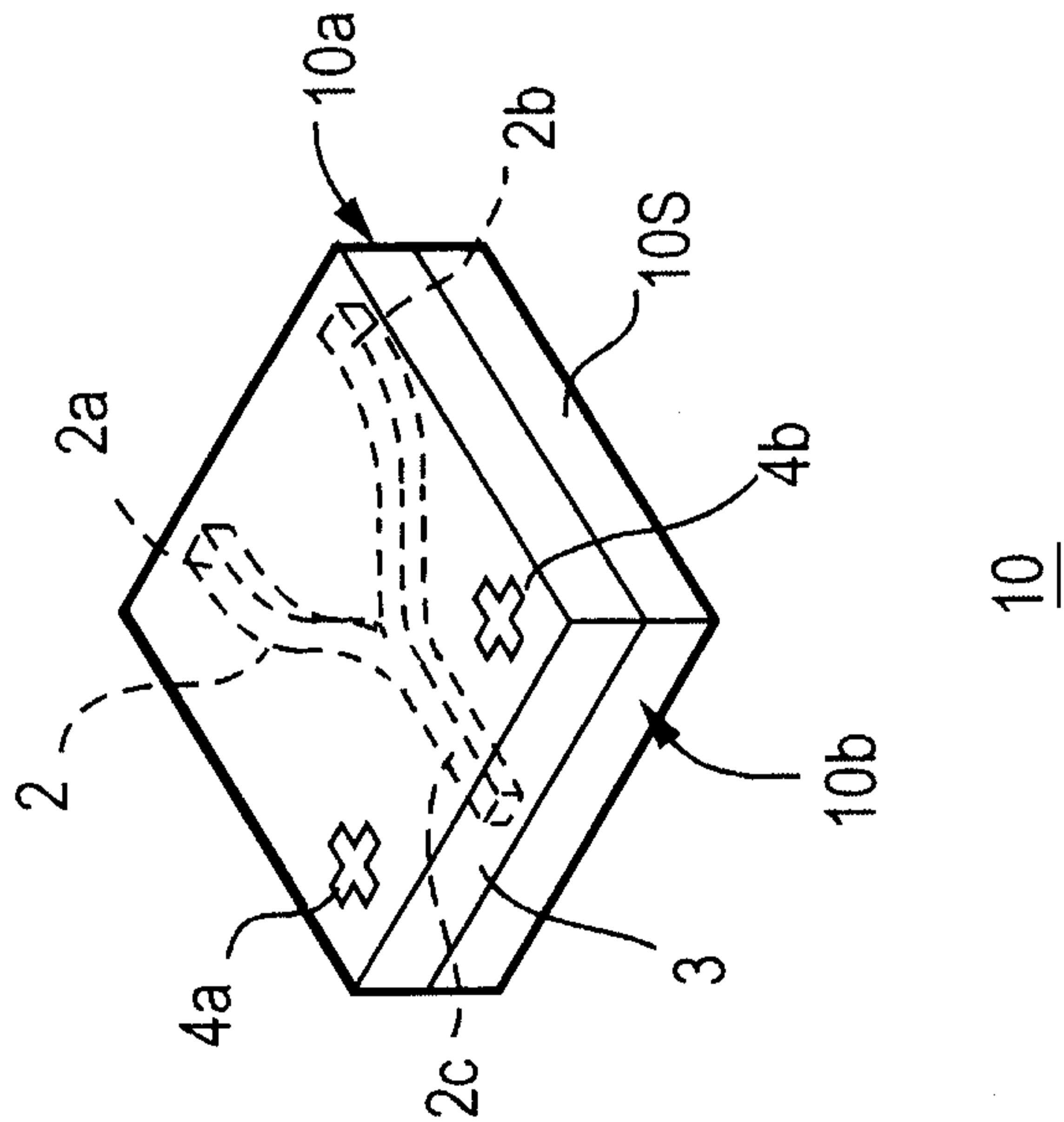

FIG. 3C

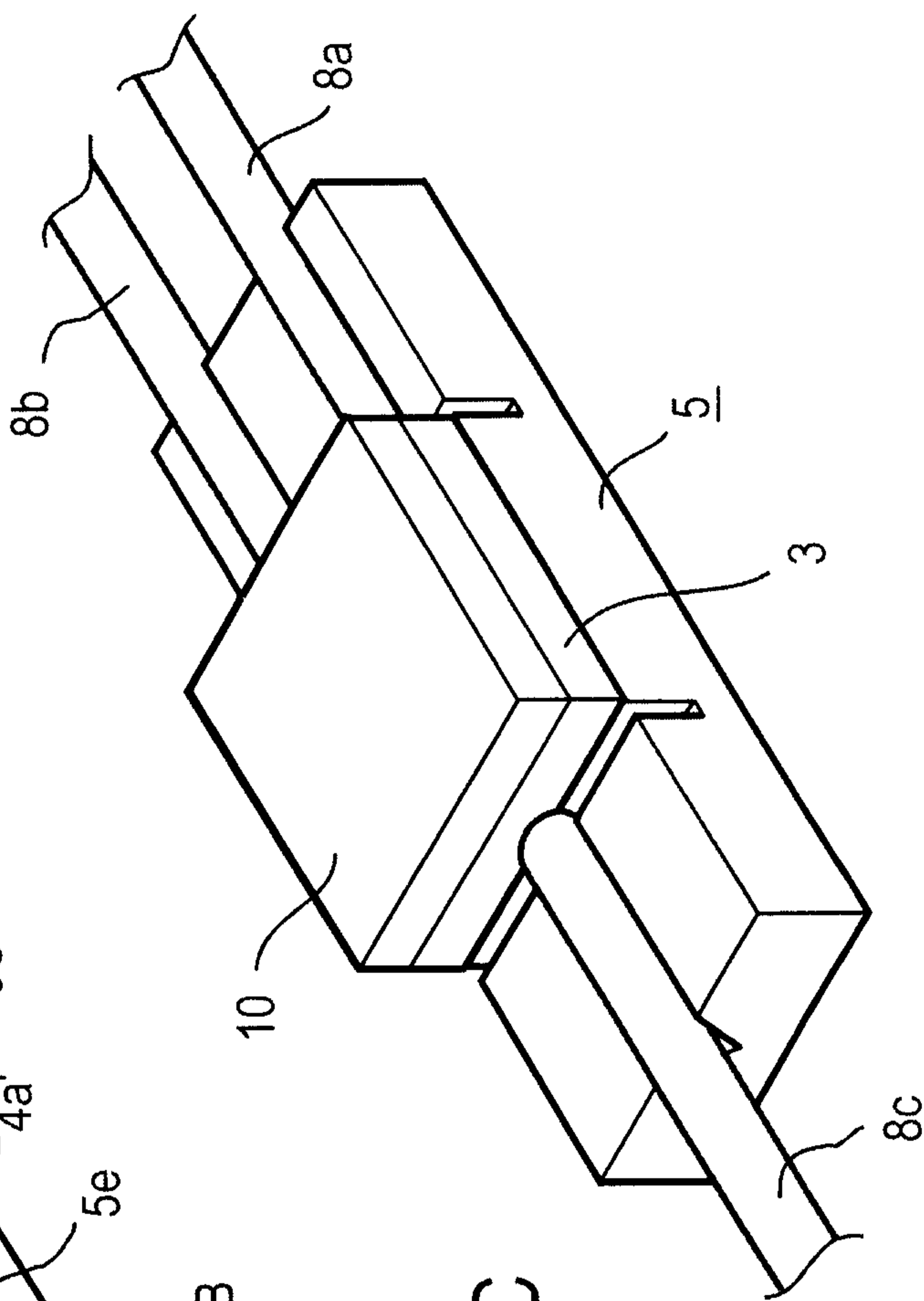

FIG. 4A

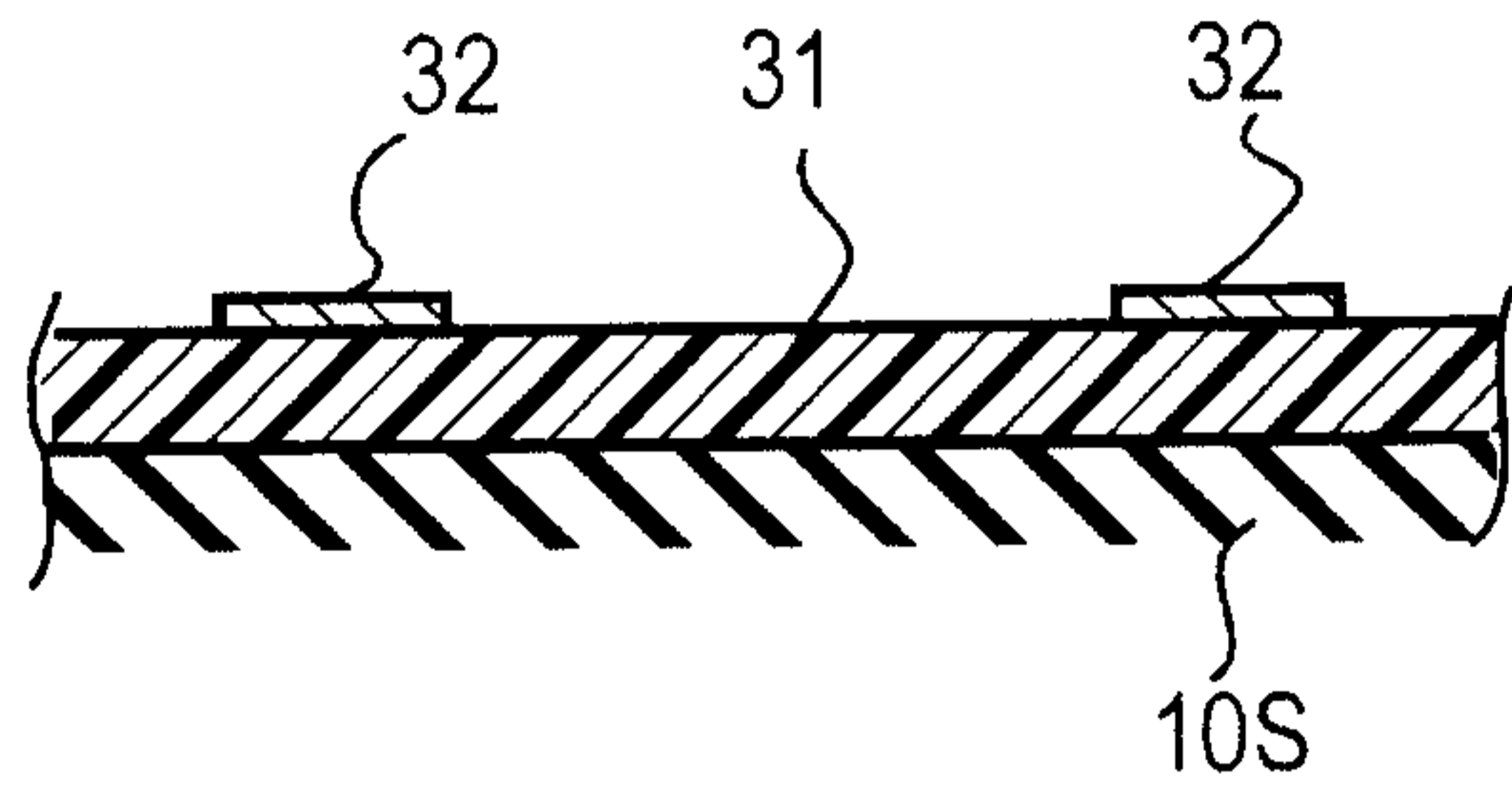

FIG. 4D

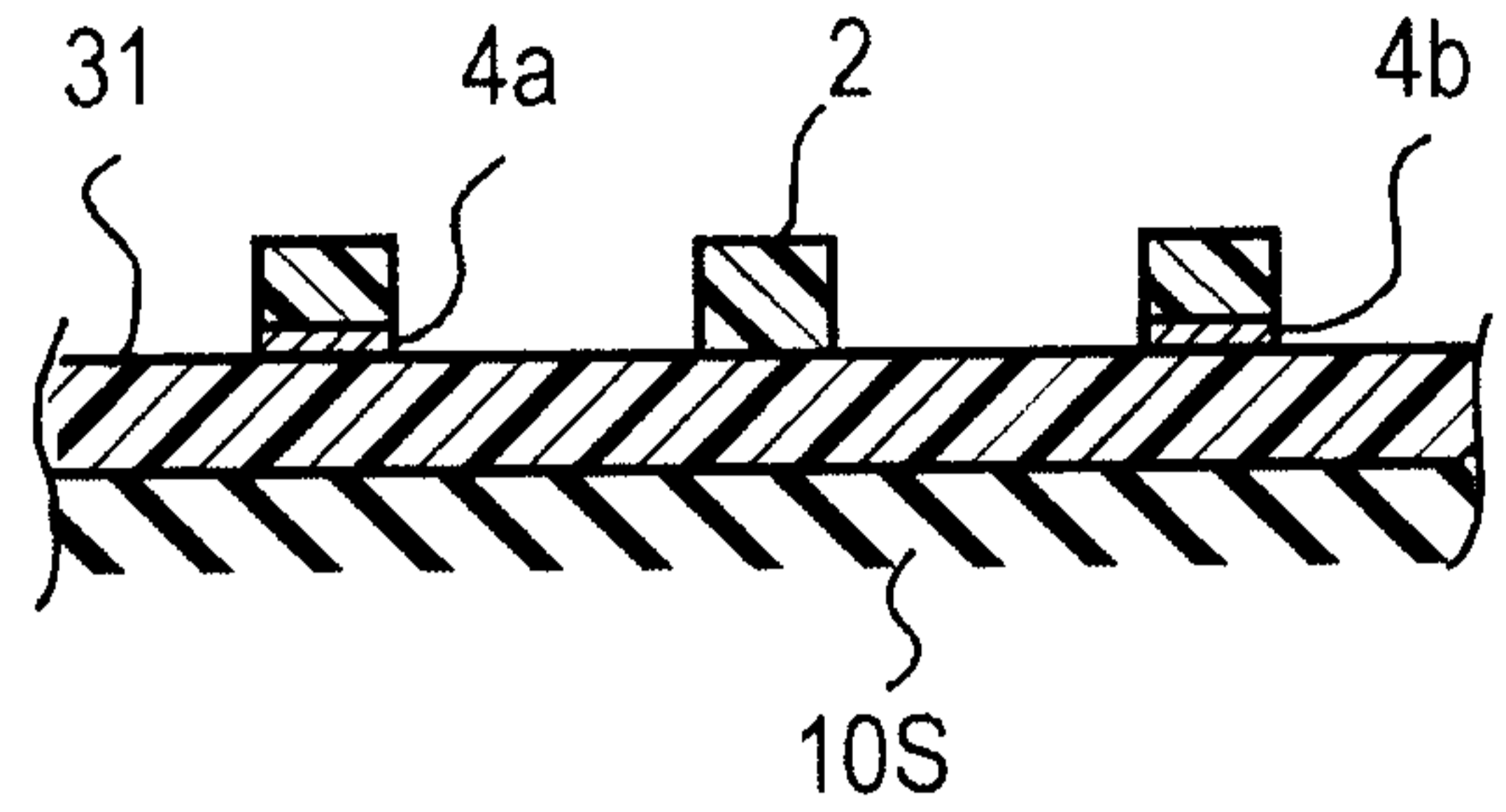

FIG. 4B

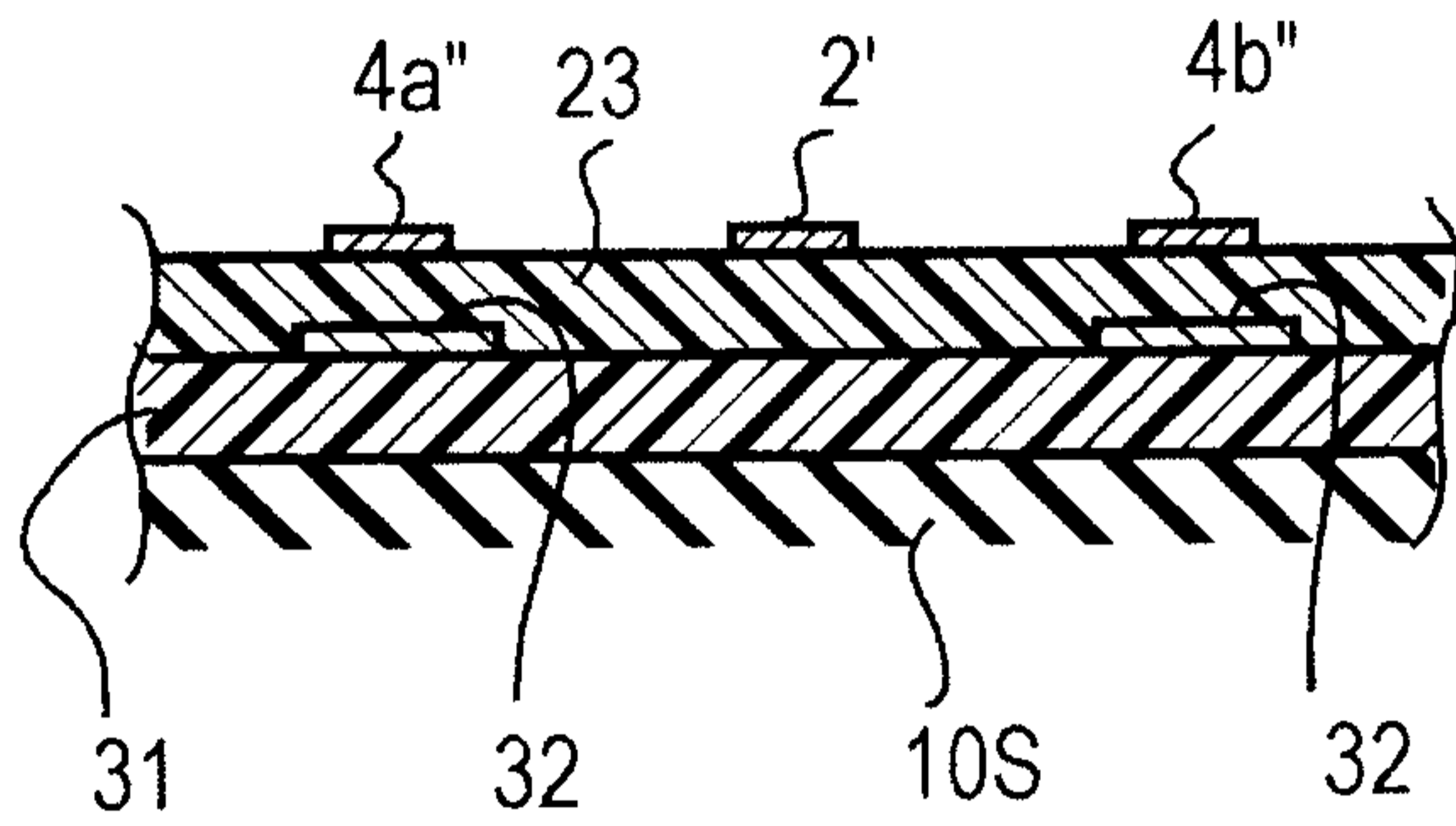

FIG. 4E

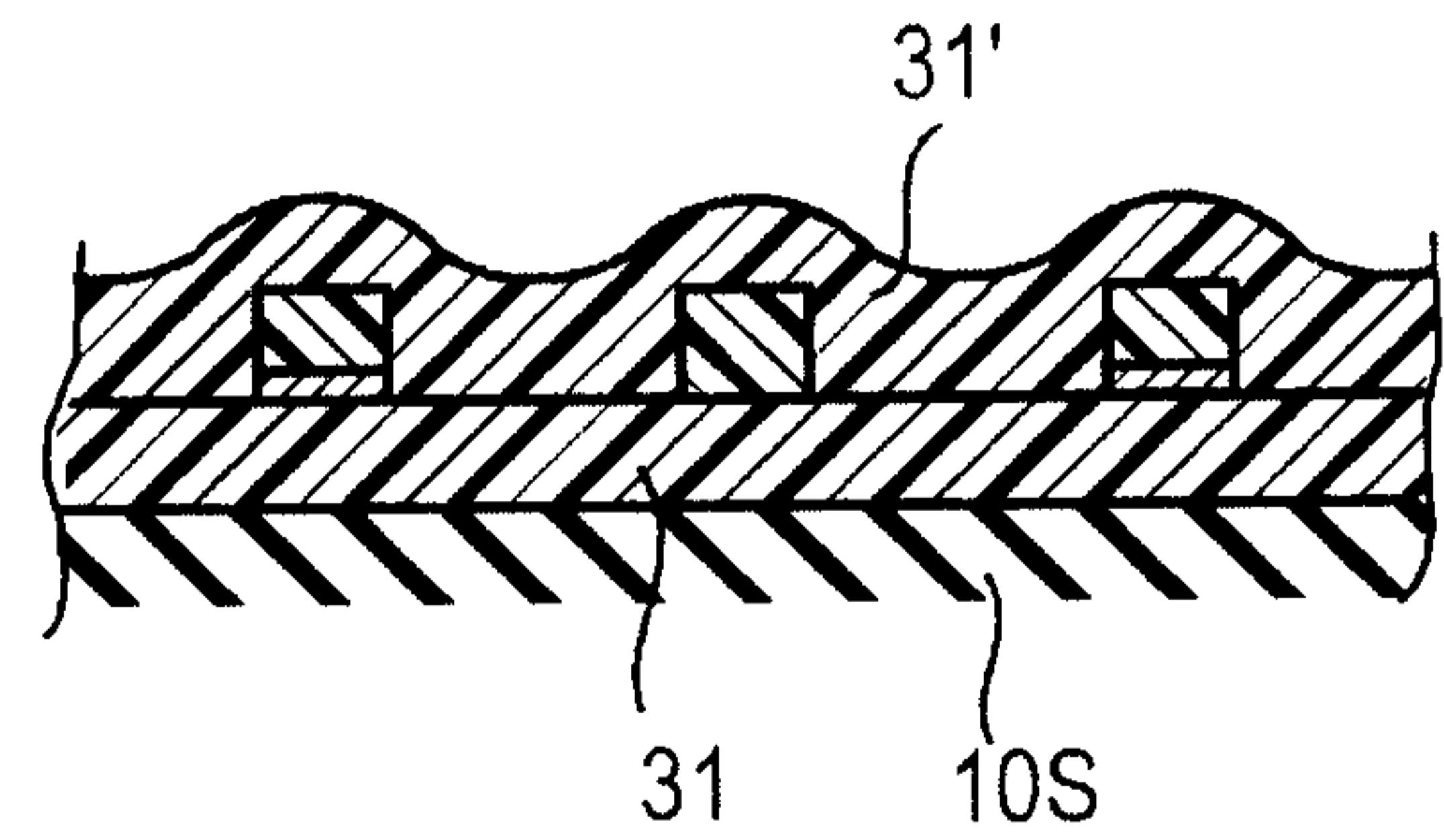

FIG. 4F

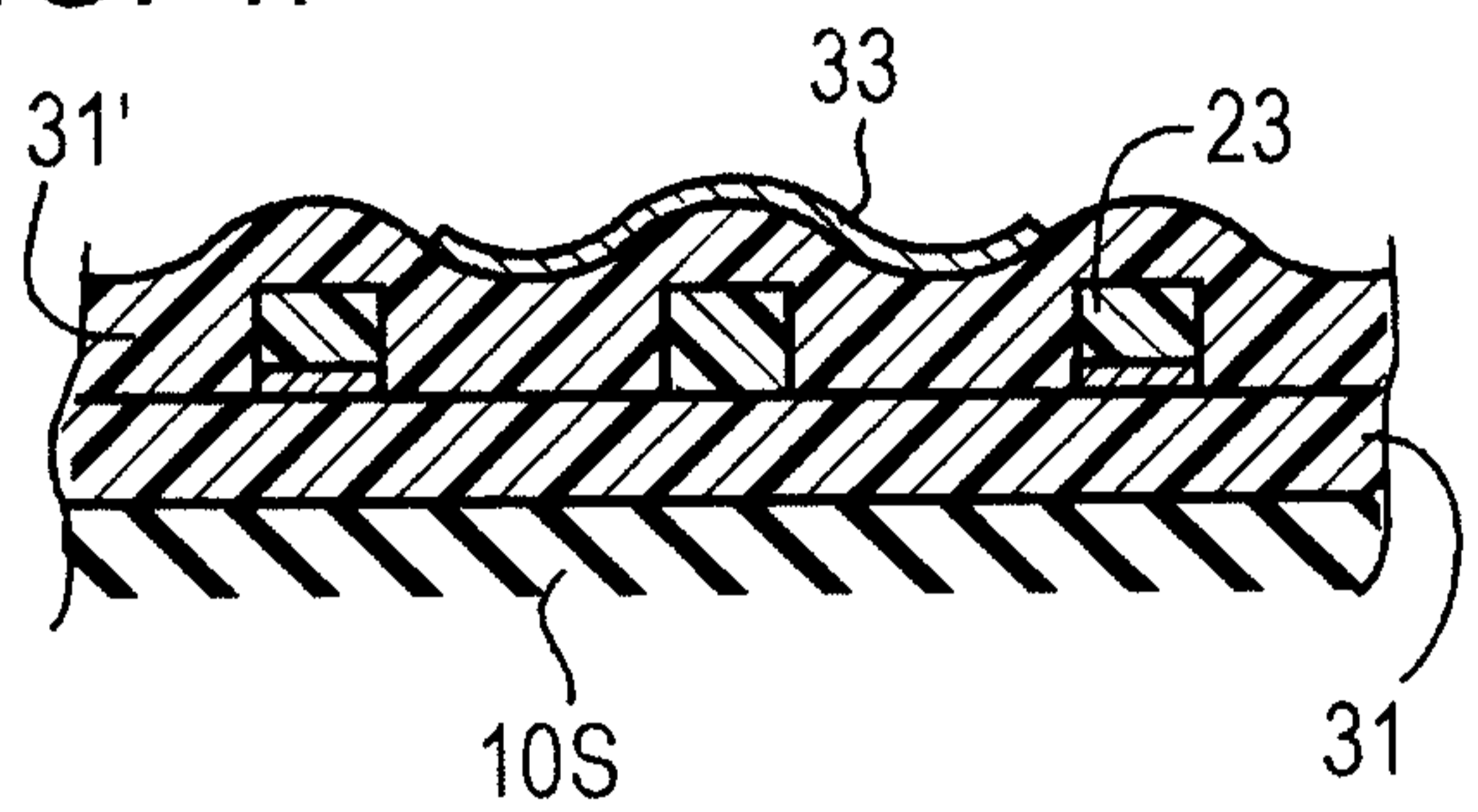

FIG. 4C

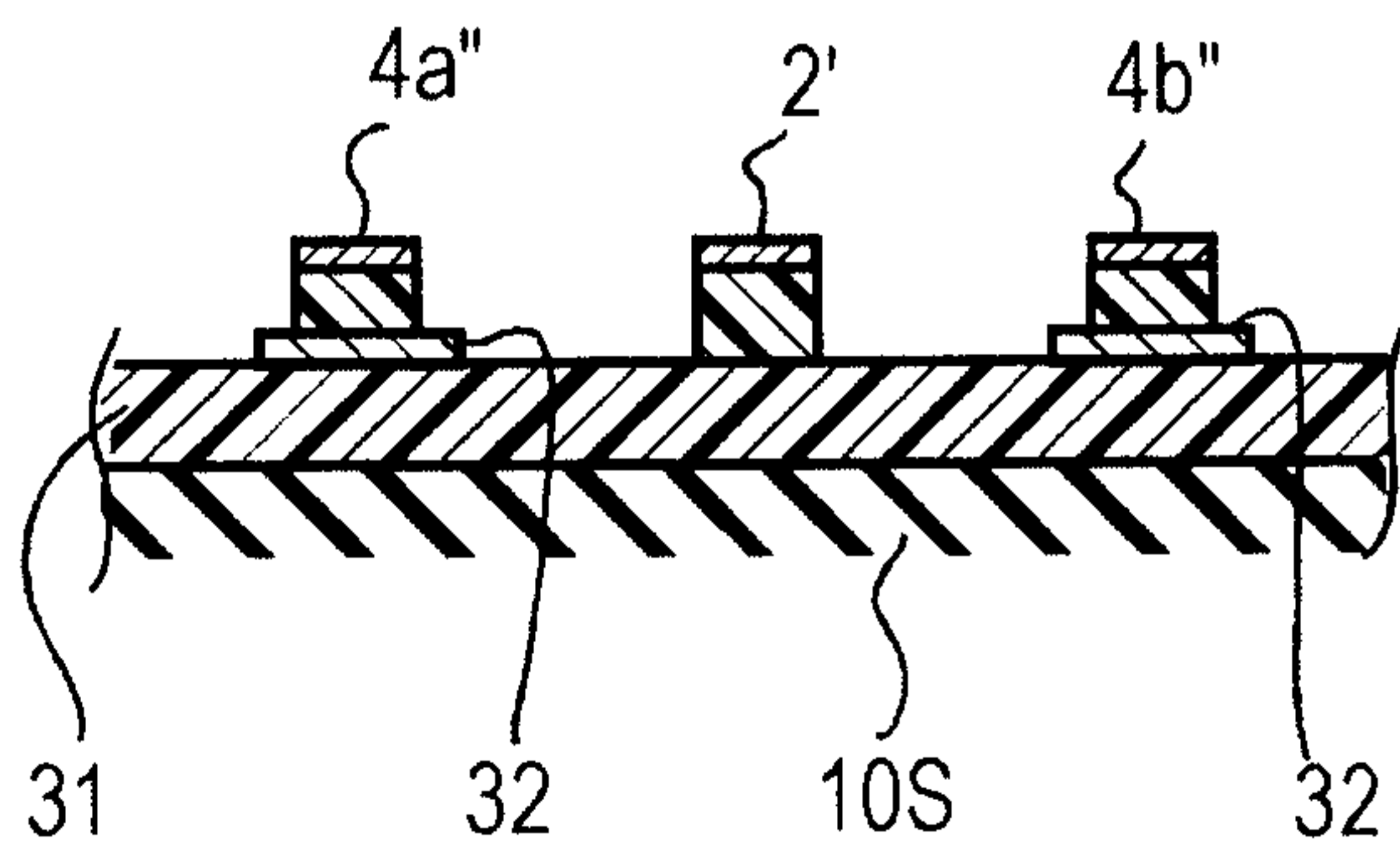

FIG. 4G

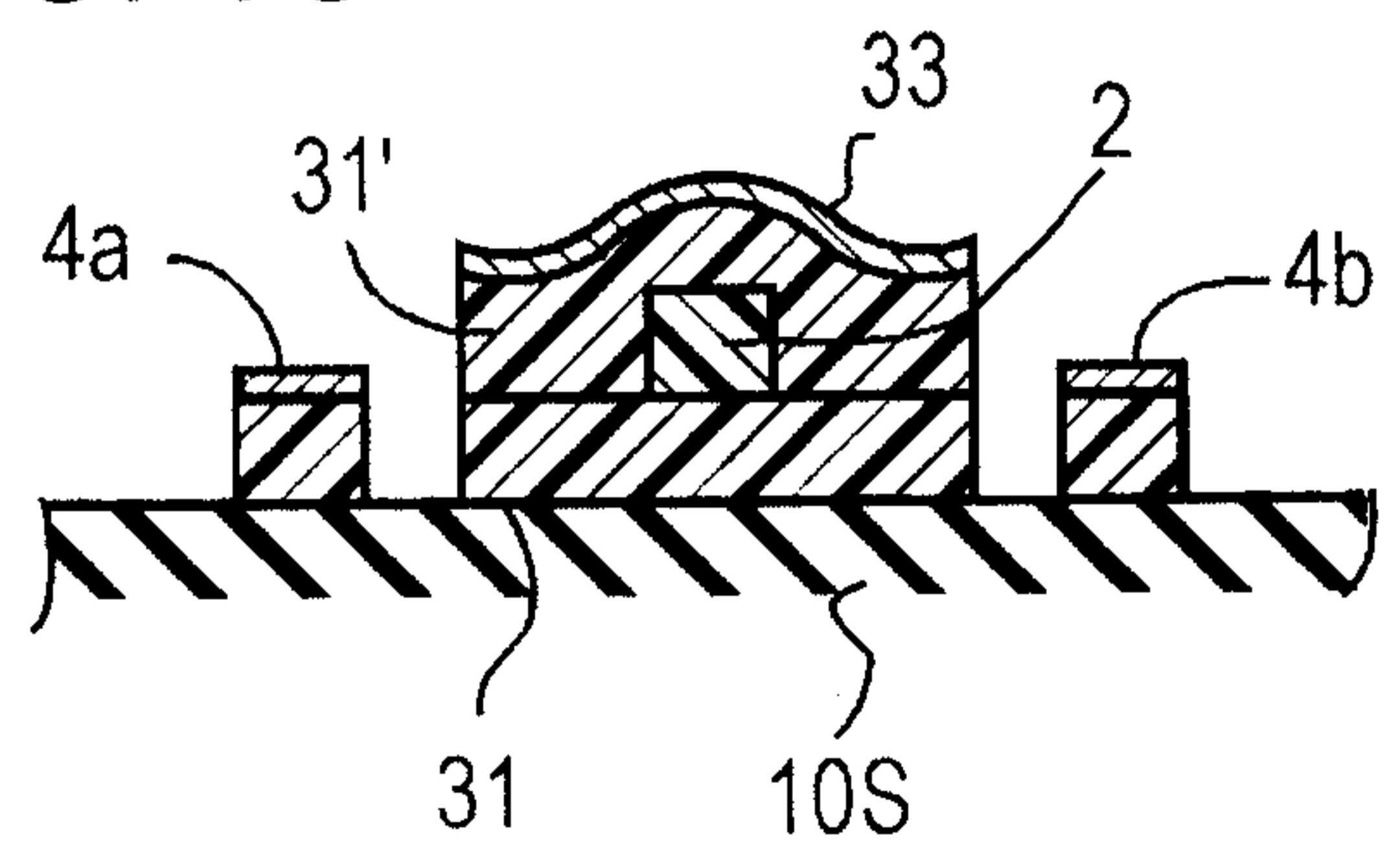

FIG. 5A

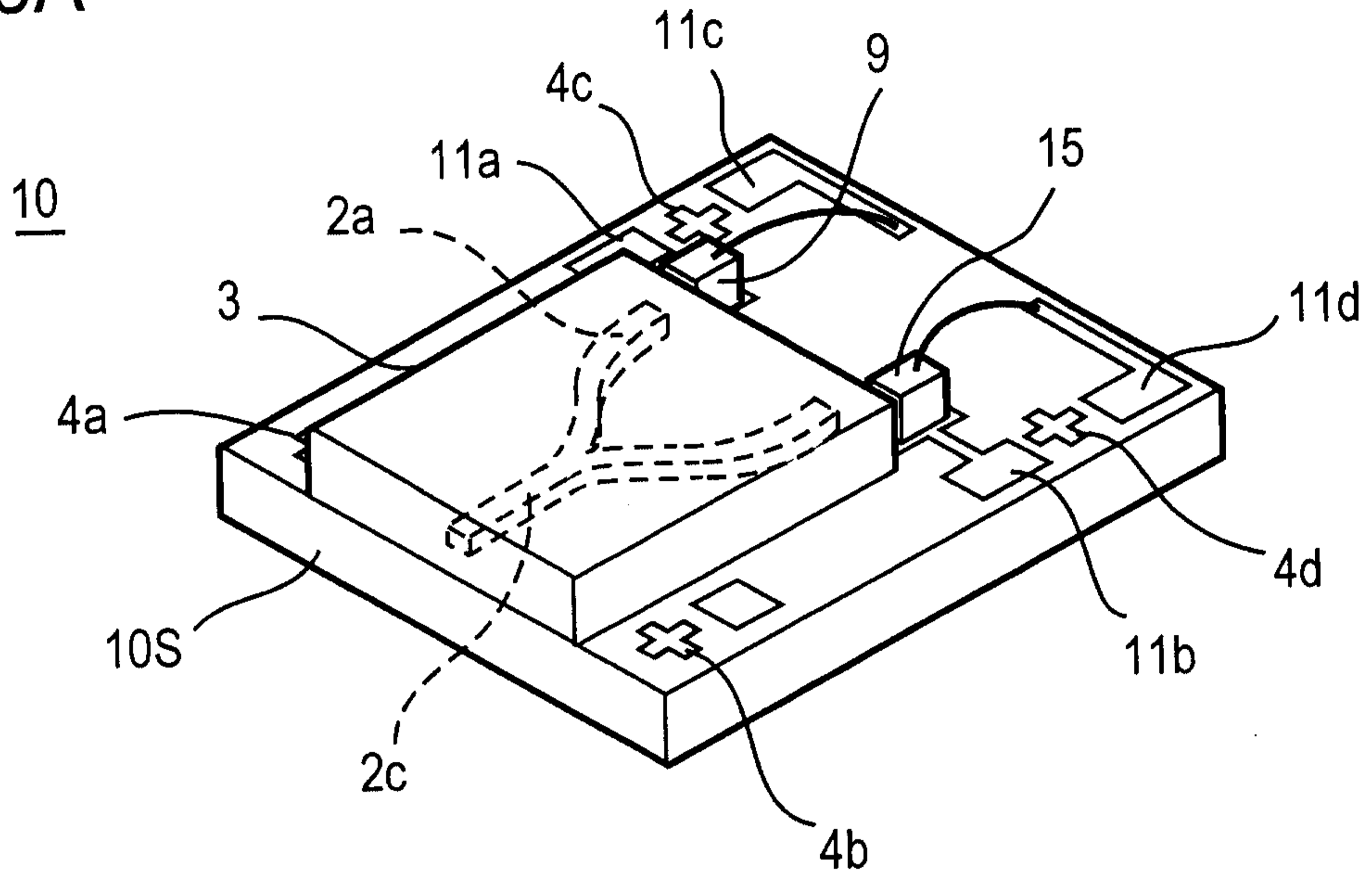

FIG. 5B

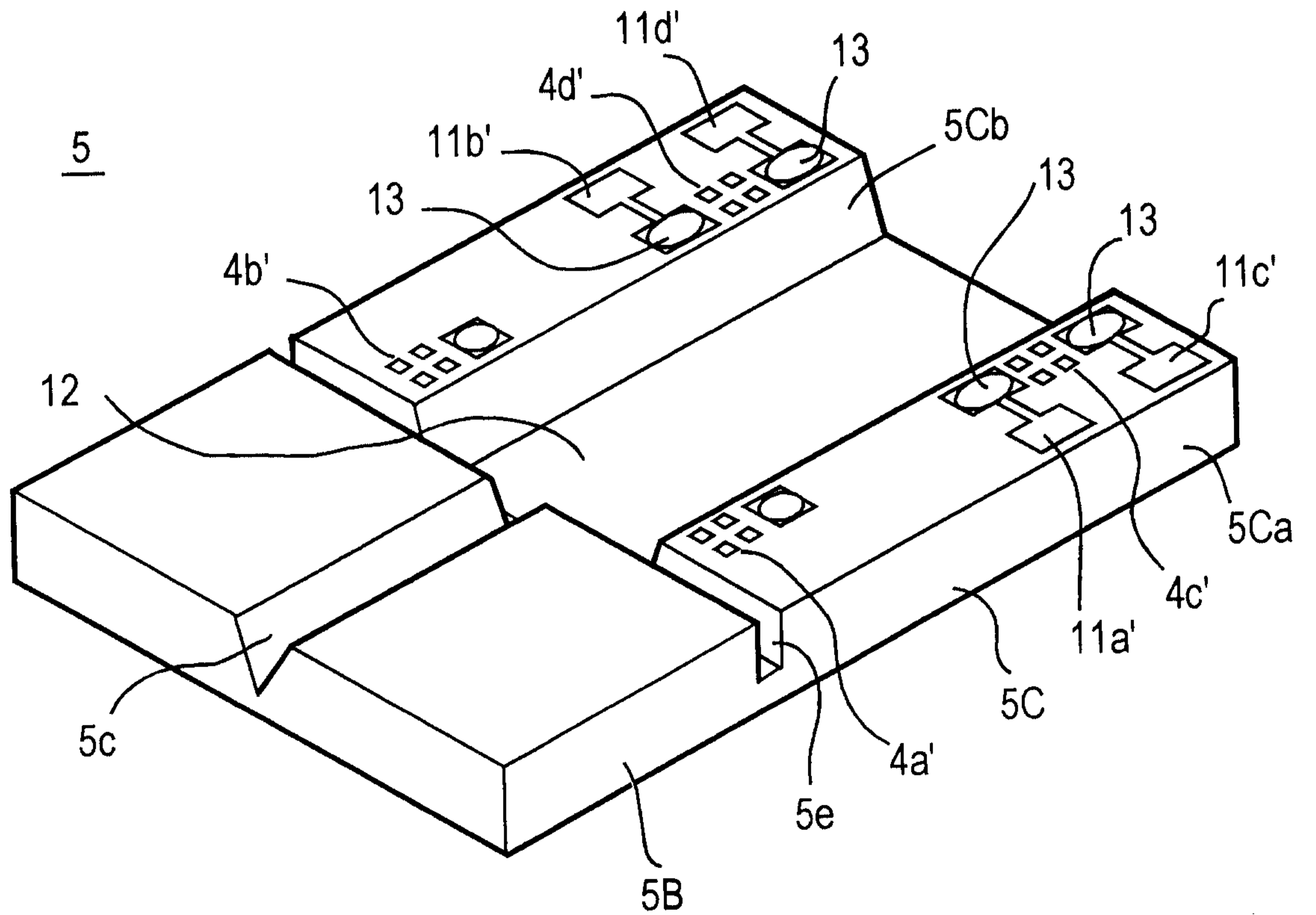

FIG. 6

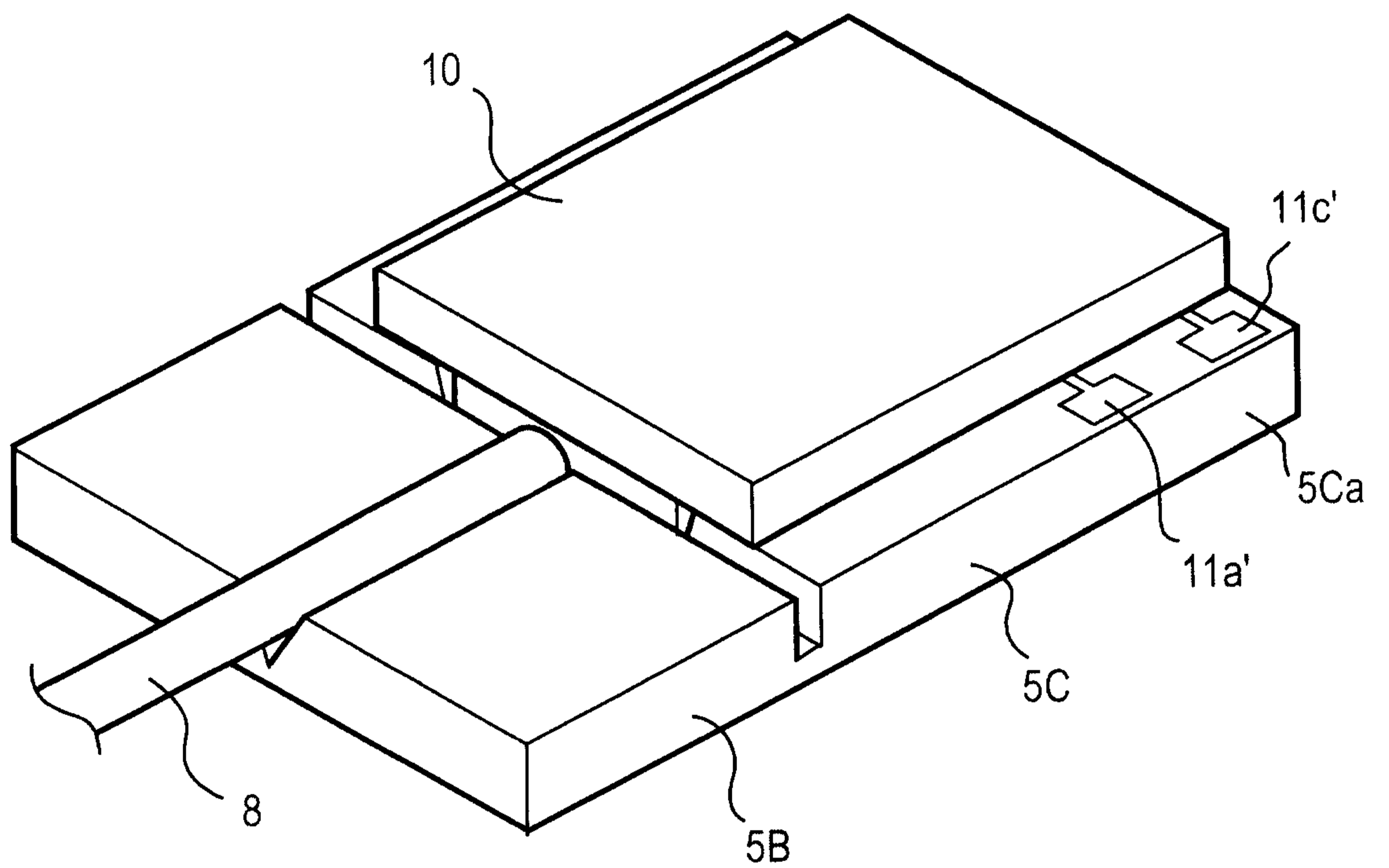

FIG. 7A

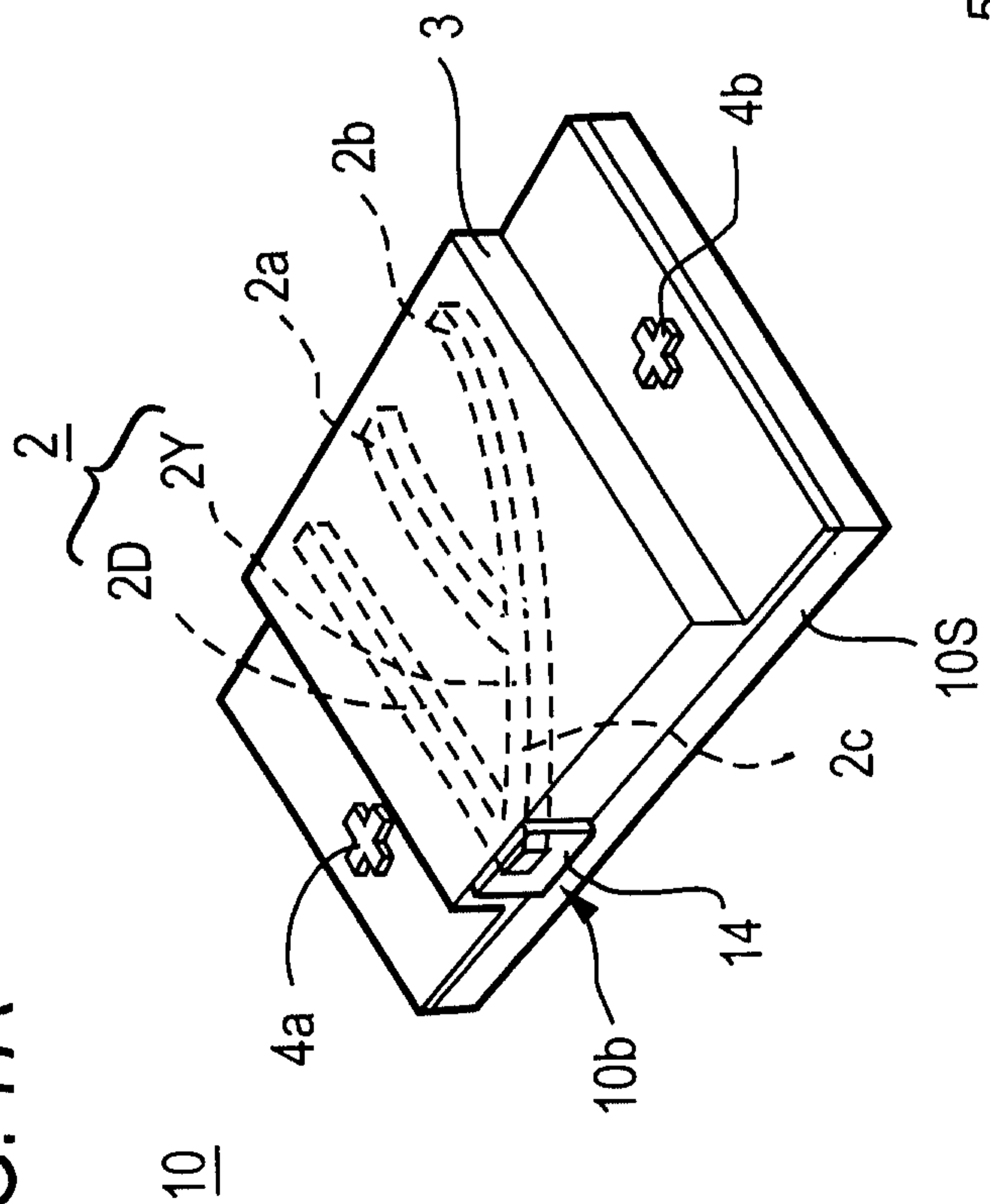

FIG. 7B

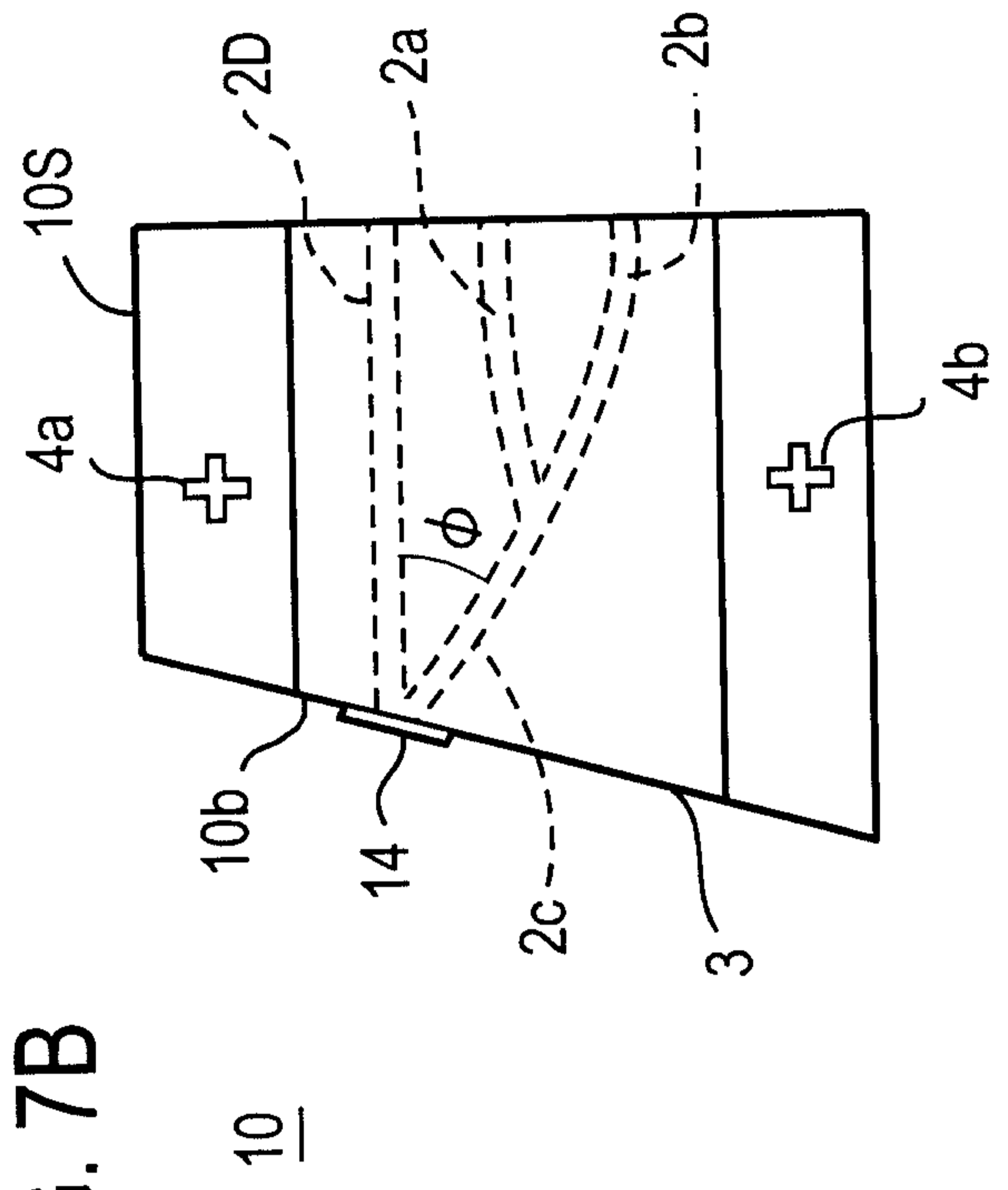
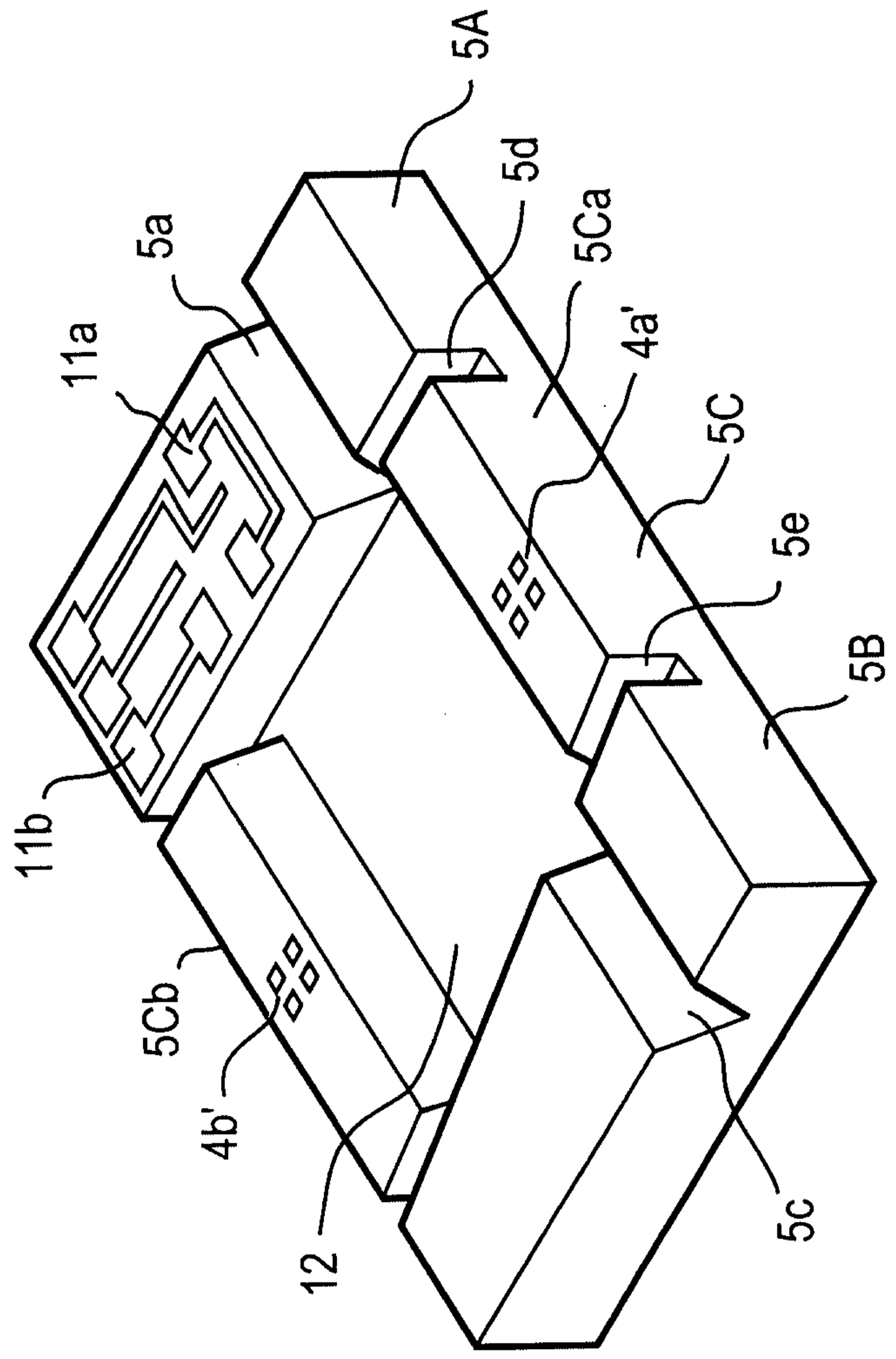

FIG. 7C



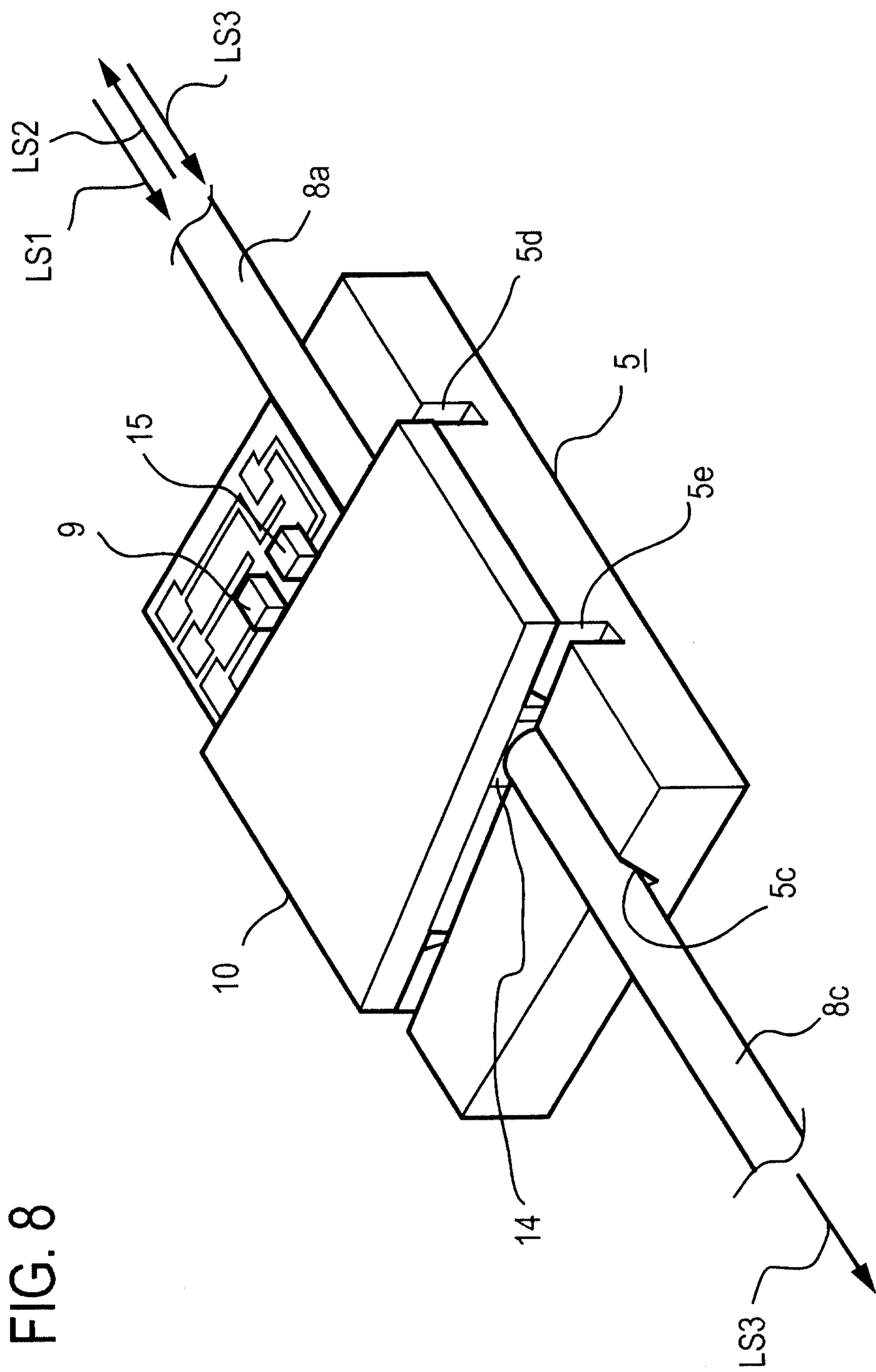

FIG. 8