

LAHAYE & WOOTTEN.

Car-Axle Box.

No. 105,096.

Patented July 5, 1870.

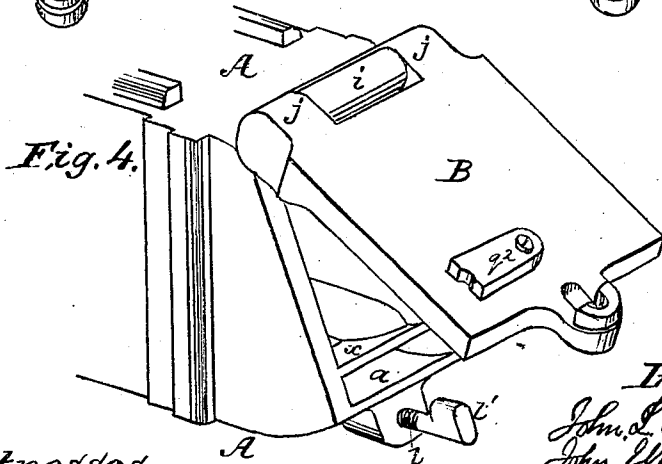
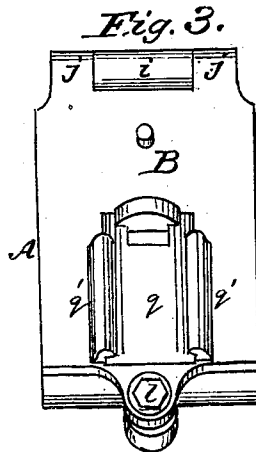
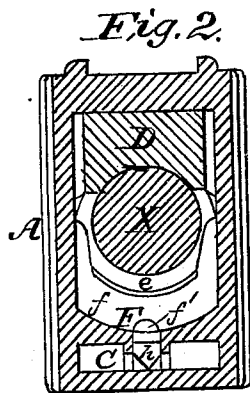
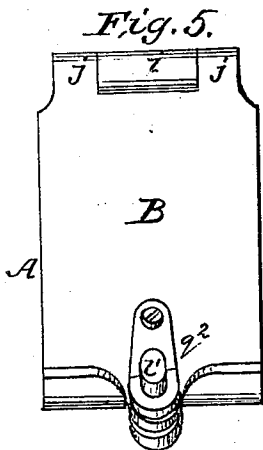
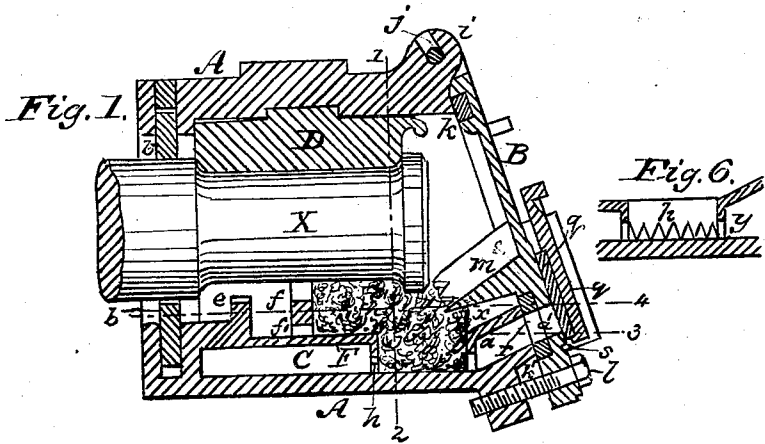

Witnesses:  
*Wm. A. Steel*  
*John B. Harding*

Inventors:  
*John S. Lahaye*  
*John E. Wootten*  
 By their attorneys  
*Houderston*

# United States Patent Office.

JOHN JOSEPH LAHAYE AND JOHN EASTBURN WOOTTEN, OF READING,  
PENNSYLVANIA.

Letters Patent No. 105,096, dated July 5, 1870.

## IMPROVEMENT IN AXLE-BOXES.

The Schedule referred to in these Letters Patent and making part of the same.

We, JOHN JOSEPH LAHAYE and JOHN EASTBURN WOOTTEN, of Reading, county of Berks, State of Pennsylvania, have invented an Improved Axle-Box, of which the following is a specification.

### *Nature and Object of the Invention.*

Our invention relates to certain improvements fully described hereafter in that class of axle-boxes which is furnished with reservoirs for lubricating material, the said improvements having been designed principally with the view of dispensing with the usual wicks employed in connection with boxes of this class, of preventing waste or leakage of the lubricating material, of affording ready means of introducing the said lubricating material into the box, and of maintaining the saturated cotton-waste in a proper position in respect to the journal of the axle.

### *Description of the Accompanying Drawing.*

Figure 1 is a longitudinal section of our improved axle-box;

Figure 2, a transverse section of the same, on the line 1 2 fig. 1;

Figure 3, a front view;

Figure 4, a perspective view of the box, slightly modified, and with the lid partly opened;

Figure 5, a front view of fig. 4; and

Figure 6, a detached sectional view of part of the box.

### *General Description.*

The box A is of the same general form as those in common use, and has at the back the usual opening for the admission of the end of the axle and an inclined front, to which is adapted a lid, B.

At the bottom of the box is an oil-reservoir, C, to which access is had from the front of the box, through an inclined passage, *a*.

At the back of the box, and surrounding the axle, is the usual packing *b*, to prevent the penetration of dust, and between the journal X of the axle and the top of the box is the ordinary bearing D.

In addition to the usual single flange *e*, near the rear of the box, beneath the journal of the axle, there is a flange, *f*, having an opening or openings, *f'*, and the bottom plate F is elevated at the rear of the flange *e*, so as to be level, or nearly so, with the lower edge of the opening in the rear of the box.

The bottom plate is inclined upward toward the front of the box, as shown at *x*, fig. 1, for a purpose described hereafter.

In the bottom plate, adjacent to the front end of the same, is an opening, which forms a communication

between the chamber C and the space beneath the axle, and from the edge of this opening, on all four sides of the same, a grated or serrated flange, *y*, extends to or nearly to the bottom of the chamber C, fig. 6.

The lid B, instead of being hinged to the front of the box or secured to the same by bolts, as usual, is merely hooked onto a slotted projection, *i*, at the top of the box; the lid having two lugs, *j, j*, and a connecting-pin, *j'*, adapted to the said projection, as best observed in figs. 1 and 4, the pin *j'* being, if desired, cast with and forming a part of the lid.

The lid is furnished with cork or other packing, *l*, and is secured at the bottom by a bolt or set-screw, *l*.

The lid described possesses this advantage over ordinary lids, that when the bolt is withdrawn it can be readily lifted and entirely detached from the box, owing to the slots in the lug *i*, when it is necessary to obtain free access to the interior of the box, or to replace the lid with a new one in case of accidental breakage.

On the inner side of the lid is a projection, *m*, which extends toward or into the space beneath the end of the axle. And in the lid beneath this semicircular projection is an opening, *a'*, coinciding with the passage *a*, which communicates with the chamber C, and this opening is covered with a cap, *q*, which is arranged to slide between vertical guides, *q'*, of the lid, so that it may be raised to a limited extent, thereby exposing the said opening, and the cap is furnished with a yielding packing, *r*, which bears against an inclined projection, *s*, on the lid of the box, the object of this inclination being to tighten the packing against the edges of the opening *a'*, when the cap is covered, as shown in fig. 3.

In preparing the box for use, the lid B is first raised or detached, and the space beneath the axle and in front of the flange *f*, is filled with cotton-waste, as is also the opening in the top of the box, and this waste is well saturated with oil.

When the lid is closed its projection *m* will be so forced against the mass of cotton-waste in the box as to press it back and maintain it in its proper position in respect to the axle, the projections, in the present instance, being serrated, so as to maintain a hold of the waste and keep it within proper limits.

In ordinary boxes of this class there is a simple opening in the bottom plate F, for the insertion of a wick, which is coiled in the reservoir, and which serves to conduct the lubricating material to the cotton-waste above.

These wicks, which are of a somewhat larger size than those used for lamps, cost from four to six cents

apiece, and have to be replaced at intervals, as they are apt to become clogged, so that aside from their inconvenience and loss of time occasioned by their proper adjustment, the annual cost of these wicks alone, on extensive railways, amounts to several thousand dollars.

By adopting the larger opening *h*, however, the wicks may be entirely dispensed with, as a portion of the cotton-waste can be introduced into the opening, so as to serve as a medium for conveying the oil to the waste above.

The object of the serrated flange extending on all four sides of the opening *a* is to prevent the cotton-waste from extending laterally into the chamber *C*. This flange may be simply perforated, or, instead of the flange, a simple perforated vessel may be introduced into the opening *h* and a portion of the waste pushed into the vessel.

It has been remarked above that in first using the box after the waste has been deposited therein, the waste is thoroughly saturated with oil; in fact, oil sufficient may be introduced when the lid is open to reach the line 4; for the oil, even if it reaches this level, cannot get behind the rear flange *e*, and the waste will prevent it from flowing outward through the opening *a*, for a short time, long enough, however, to enable the attendant to fasten down the lid, thus the box will receive a plentiful supply of oil in the outset, owing to the elevation of the bottom of the box and to the still more elevated rear flange *e*.

After this plentiful supply of oil and thorough saturation of the waste it will not be necessary to again open the lid for the purpose of replenishing the box with oil, for when the latter is so far reduced as to be below the dotted line 3, the sliding lid or cap *g* may be raised so as to expose the opening *a'* through which the oil can be passed to fill the reservoir *C* and rise in the waste so as to thoroughly lubricate the journal.

While the flange *f* serves to prevent the extension of the waste too far toward the rear of the box, and

while the flow of oil too far toward the rear is prevented by the flange *e*, any oil which may accidentally pass over the flange *f* will return to the waste through the opening or openings in the said flange.

As the bolts or set-screws *l* are apt to become lost or misplaced we propose to use a set-screw with a head of the form illustrated in fig. 4, this head being of oblong form, and projecting on one side of the screw, and the lid having an opening of corresponding form, to admit the head, which by turning the screw can be brought to bear, not only on the lid, but on an arm, *q*<sup>2</sup>, which is hung to the same.

When this arrangement is adopted the cap *g* may be dispensed with, as the lid can be readily opened for introducing oil into the box.

#### Claims.

1. The projection *m*, arranged on the lid *B*, for controlling the waste in the interior of the box, as set forth.

2. The arrangement of the flange *e*, flange *f*, opening *f'*, and body of waste in front of the flange *f*, as and for the purpose described.

3. An opening, *h*, in the bottom of the box, for receiving a portion of the said waste, when the latter is confined by a serrated flange, or its equivalent, substantially in the manner described.

4. The combination of the lid *B*, its inclined projection, *s*, guides *q' q'*, and the sliding cap *g*, with its packing, as set forth.

5. The set-screw *l*, having a head, *z*, of the form described, in combination with the cover *B*.

In testimony whereof we have signed our names to this specification in the presence of two subscribing witnesses.

JOHN JOSEPH LAHAYE.  
JOHN EASTBURN WOOTTEN.

Witnesses:

F. KELTON,  
MATTHIAS MARGEL.