

W. V. TEETER.
 STRAW ELEVATOR.
 APPLICATION FILED JULY 3, 1909.

973,892.

Patented Oct. 25, 1910.

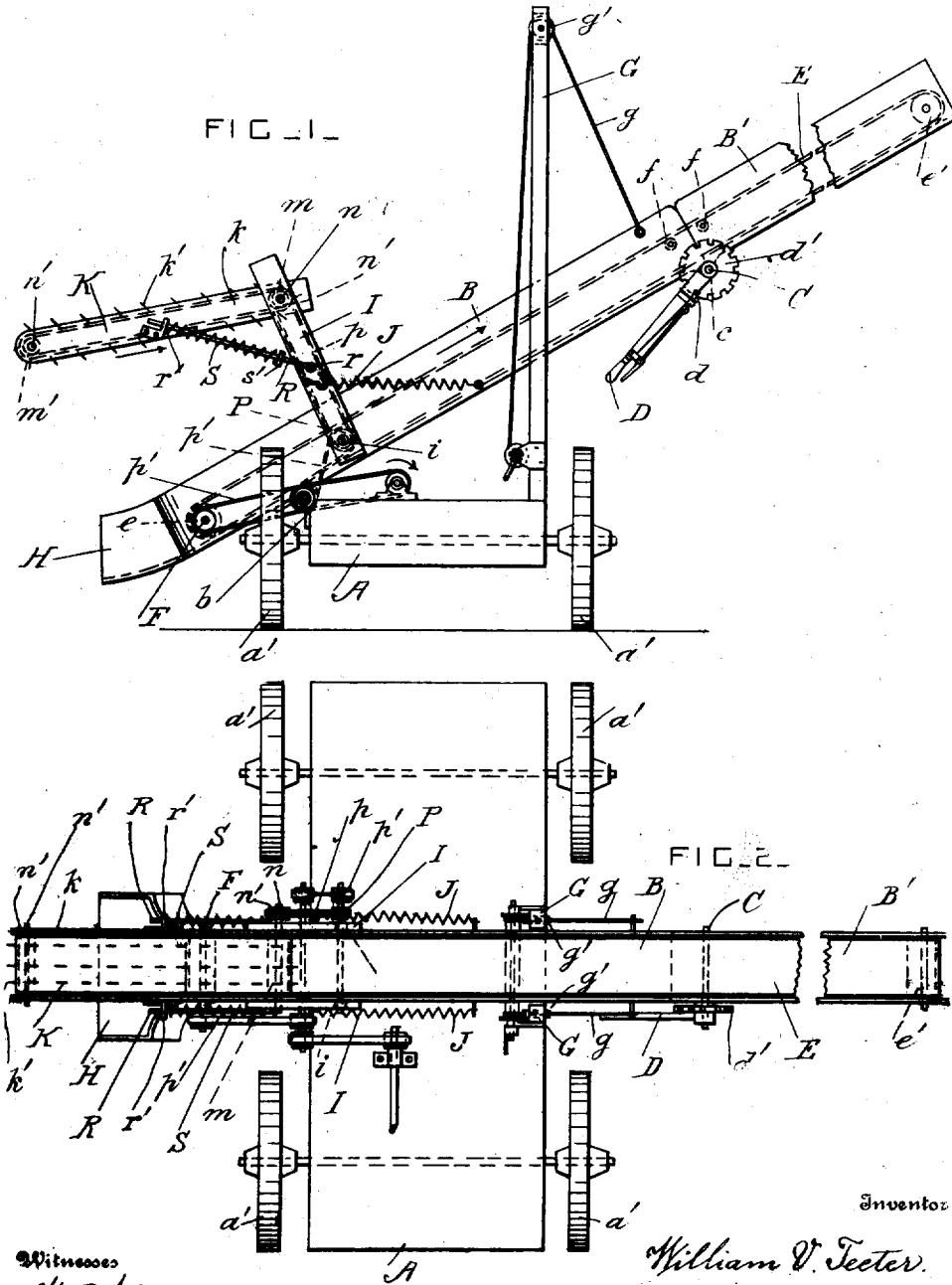

Witnesses
 W. Allen
 L. B. Middleton

Inventor
 William V. Teeter.
 Hubert W. D. Jenner.
 Attorney

UNITED STATES PATENT OFFICE.

WILLIAM V. TEETER, OF GRINNELL, KANSAS.

STRAW-ELEVATOR.

973,892.

Specification of Letters Patent. Patented Oct. 25, 1910.

Application filed July 3, 1908. Serial No. 505,917.

To all whom it may concern:

Be it known that I, WILLIAM V. TEETER, a citizen of the United States, residing at Grinnell, in the county of Gove and State of Kansas, have invented certain new and useful Improvements in Straw-Elevators; and I do hereby declare the following to be a full, clear, and exact description of the invention, such as will enable others skilled in the art to which it appertains to make and use the same.

This invention relates to elevators specially constructed for unloading loose unthreshed grain from wagons; and it consists in the novel construction and combination of the parts hereinafter fully described and claimed.

In the drawings, Figure 1 is an end view of the stacker. Fig. 2 is a plan view of the stacker.

A is a truck or carriage of any approved construction provided with wheels *a'* for road or for rail. This truck has any suitable motor (not shown) mounted on it, and it is preferably provided with self-propelling gear of any approved construction, which is driven by the said motor, so that the machine may be transported from place to place.

B is a straw-elevator, the lower section of which is hinged to one side of the truck A by hinges *b*, between two of the wheels *a'*. The lower end portion of the elevator projects at one side of the truck, and its upper end portion projects at the other side of the truck.

B' is the upper section of the elevator, which is pivoted to the lower section B by a shaft C. The shaft C is rigidly secured to the upper section and is journaled in bearings *c* on the lower section.

D is an operating handle or lever which is rigidly secured to one end portion of the shaft C, and which is provided with a retractable catch *d'* which engages with a notched plate *d'* which is rigidly secured to the lower section B.

E is an endless elevator carrier arranged in the trough-shaped frames of the upper and lower elevator sections. The end portions of the carrier E pass over rollers *e* and *e'*, and the lower roller *e* is secured on a shaft F which is driven from the motor by any approved intermediate driving wheels or connections.

Suitable guide rollers *f* are provided for

supporting the middle parts of the carrier.

The upper section of the elevator can be arranged in line or out of line with the lower section, as required; and when the machine is being transported from place to place, the upper section is folded with respect to the lower section. The upper section of the elevator is turned downward out of line with the lower section, so that it does not project to an inconvenient extent, when the machine is drawn along, and the upper section may be secured in a vertical position or in any other convenient position.

The upper parts of the elevator are arranged between uprights G, and *g* is a cord which passes over a guide-sheave *g'* at the upper part of one of the uprights. One end of this cord is secured to the elevator, and the other end is secured to the upright or to the truck. Any approved winding-mechanism can be provided, if desired, for winding up the cord and raising the elevator. The lower end portion of the elevator projects below the truck and the tops of the wheels *a'* when the elevator is raised, and it is provided with a curved receiving hopper H which is wider than the elevator.

I are arms which are pivoted by pins *i* to the lower part of the elevator above the hopper, and which project upwardly and away from the elevator.

J are springs between the arms I and the lower section of the elevator. These springs sustain the arms in their raised position.

K is a drag-rake. The frame *k* of this drag-rake is pivoted to the upper end portions of the arms I, and the drag-rake is provided with endless traveling bands and cross-slats provided with teeth *k'*. The endless bands are carried by wheels *m* and *m'* secured on shafts *n* and *n'* which are journaled at the end portions of the drag-rake. The upper shaft *n* is the driving-shaft and it is provided with a driving-wheel *n'*.

The driving-wheel *m* is driven by an endless drive-chain *p* from a driving-wheel P at the lower part of the elevator, and this driving-wheel P is driven by the motor on the truck in any approved manner. The driving-wheel P is preferably connected with the driving-shaft of the elevator by any approved intermediate driving-devices *p'*, so that the elevator and the drag-rake are driven simultaneously. The arrows in Fig. 1 show the directions of the motion of the drag-rake and the elevator.

R are rods pivoted at one end by pins *r* to the arms I. The other end portions of the rods R are slidable in guides *r'* secured to the sides of the frame of the drag-rake.

5 Sustaining springs S are arranged around the rods R between the guides *r'* and collars *s'* on the rods, and these springs normally hold the drag-rake in a raised position, as shown in Fig. 1.

10 A wagon containing unthreshed grain in loose form is arranged alongside the truck, and under the free end portion of the drag-rake. The free end portion of the drag-rake is pressed down by hand onto the

15 grain, and the grain is dragged by the teeth into the hopper, and is carried up the elevator by the endless carrier and is delivered at the opposite side of the truck from the wagon. As the elevator is arranged cross-

20 wise of the truck and between its wheels, it is always well balanced. The springs J permit the drag-rake to be pressed into engagement with the grain, and permit the arms I to move on their pivots to let the drag-rake

25 be moved up and down. The springs J also raise the arms I toward their vertical position automatically when the free end portion of the drag-rake is lifted up by hand.

This machine can also be used to stack 30 grain in bundles, or any other material similar to straw. The wagons are mounted on wheels, and two or more wagons are preferably used, so that when one wagon is being discharged by the straw-stacker, another 35 wagon is being filled by the header which cuts the grain in the field.

The self-propelling mechanism (not shown) is used to move the straw-stacker 40 about from field to field, and from stackyard to stackyard. It is preferably driven by the same engine which drives the elevator mechanism, but a separate engine may be provided to propel the truck, if desired, 45 or the machine may be moved about in any other approved manner.

What I claim is:

1. In a straw elevator, the combination, with a truck, of a straw carrier pivotally supported by the truck and having end 50 portions of unequal length which project on opposite sides of its pivot, the shorter end portion being provided with a receiving hopper of greater width than its main portion, said hopper being an extension of the

carrier frame and arranged substantially in 55 line with it, means for supporting the straw carrier in an inclined position with the hopper projecting below the top of the truck, arms having their lower parts pivoted to 60 the longer end portion of the straw carrier, a drag-rake pivoted at one end to the upper parts of the said arms with its free end projecting over the said hopper and adapted to drag the straw into it, and means for supporting the upper parts of the said arms 65 from the straw carrier and permitting them to be moved pivotally.

2. The combination, with a truck mounted on wheels, of a straw-elevator hinged to one side of the truck and projecting crosswise 70 thereof between its wheels, spring-supported arms having their lower end portions pivoted to the lower end portion of the elevator, a drag-rake pivoted at one end to the upper end portions of the said arms and arranged 75 to feed the straw onto the elevator, and means for supporting the upper part of the elevator from the truck.

3. The combination, with a straw-elevator, of spring-supported arms having their 80 lower end portions pivoted to the lower end portion of the elevator, and a drag-rake pivoted at one end to the upper end portions of the said arms and arranged to feed the straw onto the elevator. 85

4. The combination, with a straw-elevator, of arms pivoted to the elevator, supporting springs arranged between the said arms and the elevator and permitting the arms to be moved pivotally, and a drag-rake 90 pivoted to the free end portions of the arms.

5. The combination, with a straw-elevator, of spring-supported arms having their lower end portions pivoted to the lower end portion of the elevator, a drag-rake pivoted 95 at one end to the upper end portions of the said arms and arranged to feed the straw onto the elevator, guides secured to the sides of the drag-rake, rods pivoted to the said arms and slidable in the said guides, and supporting springs carried by the said rods 100 and bearing against the said guides.

In testimony whereof I have affixed my signature in the presence of two witnesses.

WILLIAM V. TEBETER.

Witnesses:

PETER DE BOER,
J. E. BORAH.