

Jan. 27, 1953

L. HORNOSTEL

2,626,543

FLUID PRESSURE SEALED GARTER STRAP FOR CYLINDER MOLDS

Filed Oct. 27, 1948

2 SHEETS—SHEET 1

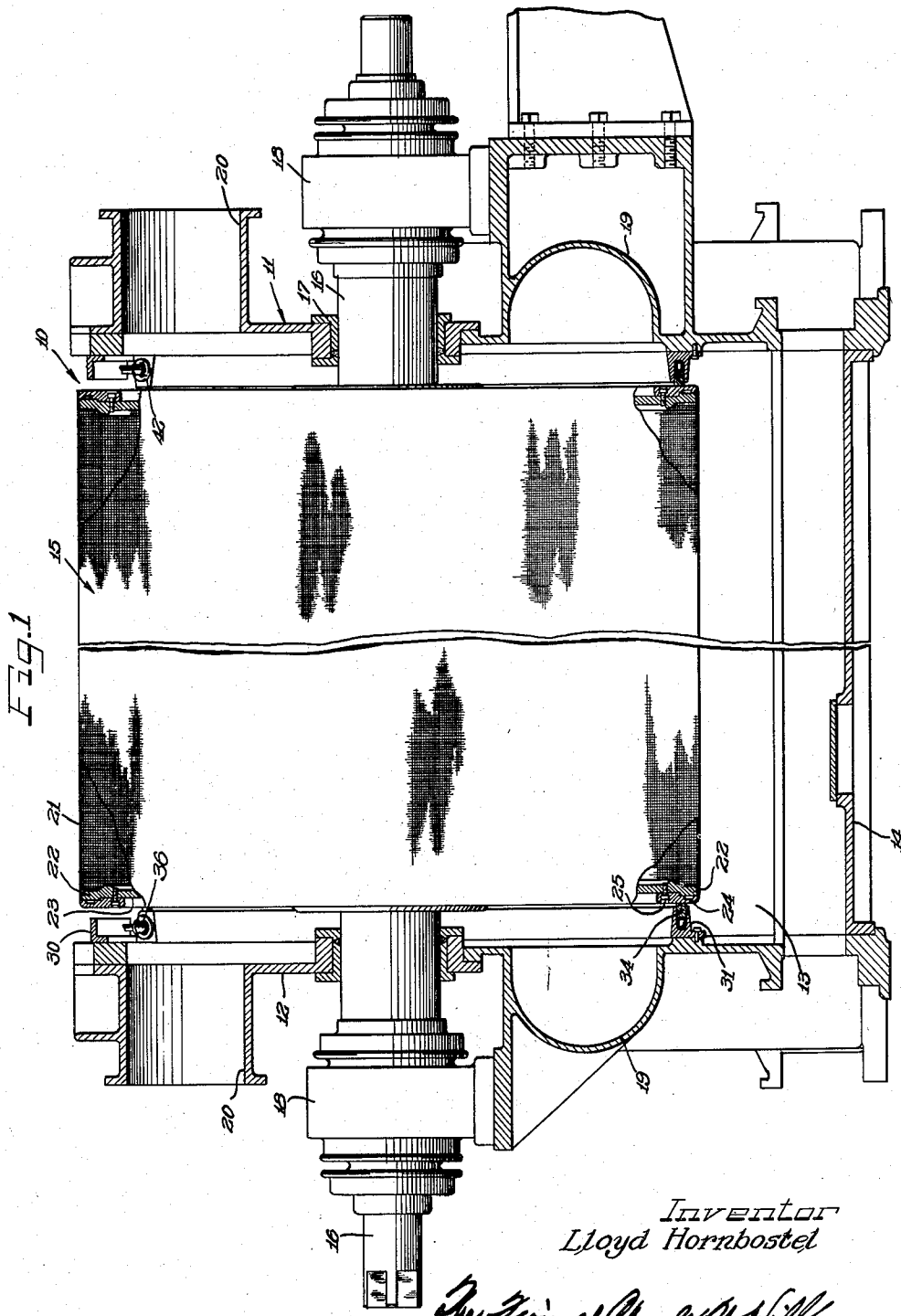

Inventor
Lloyd Hornostel

By *Charles H. Mills*
ATTORNEYS

Jan. 27, 1953

L. HORNBOSTEL

2,626,543

FLUID PRESSURE SEALED GARTER STRAP FOR CYLINDER MOLDS

Filed Oct. 27, 1948

2 SHEETS—SHEET 2

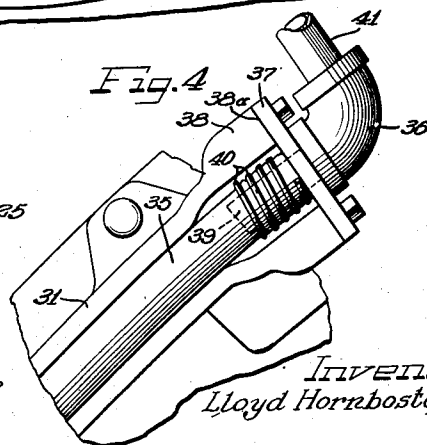
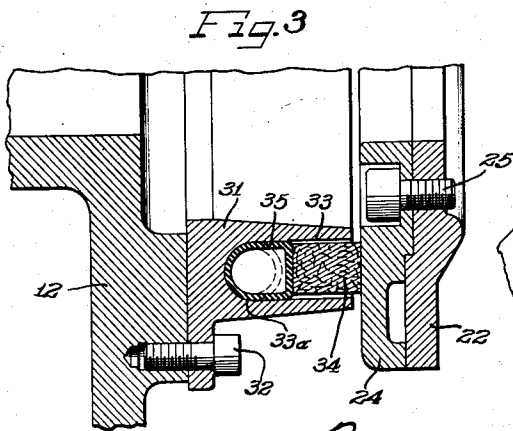
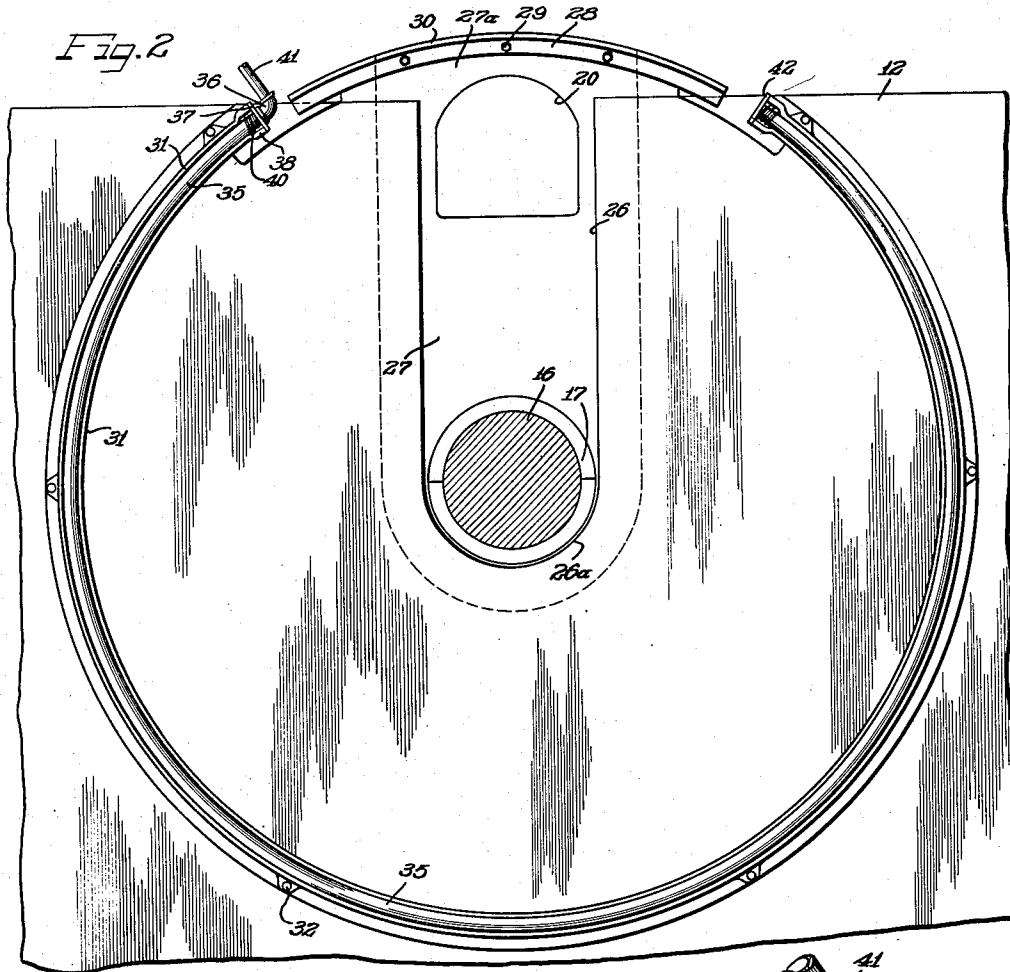

Inventor
Lloyd Hornbostel

By *Charles H. Hill* Atty=

UNITED STATES PATENT OFFICE

2,626,543

FLUID PRESSURE SEALED GARTER STRAP FOR CYLINDER MOLDS

Lloyd Hornbostel, Beloit, Wis., assigner to Beloit
Iron Works, Beloit, Wis., a corporation of Wis-
consin

Application October 27, 1948, Serial No. 56,808

5 Claims. (Cl. 92-43)

1

The present invention relates to a fluid pressure sealed garter strap for cylinder-type paper machines and more particularly to a liquid-tight seal for sealing the circular end faces of a cylinder mold despite frictional wear of the seal in operation of the machine.

In cylinder-type paper making machines a cylinder provided with a foraminous or screen-covered exterior is rotated within a stock vat containing a pond of pulp suspension within which the cylinder mold is partially immersed. The exterior of the cylinder mold is evacuated and as the mold rotates, the pond liquid passes through the foraminous surface of the mold and out through the circular end faces of the mold into drain boxes carried by the vat side walls. As the liquid passes through the foraminous mold surface, a deposition of pulp fibers is formed upon this surface as a web. The web is removed from the mold surface by means of a pick-up felt which is pressed against the mold surface by means of a couch roll.

The circular end faces of the cylinder mold are open to permit the evacuation of the center of the mold and also to permit the egress of white water passing through the cylinder surface to deposit fibers thereon. A proper sealing of the end faces of the mold has been a problem longstanding in the art and numerous expedients have been proposed for effectively sealing these faces. However, in each instance of the prior art, frictional losses during operation of the machine have seriously hampered the effective sealing of the cylinder ends and it has become necessary to frequently shut down the machine so that the sealing means may be replaced. This shutting down of the machine has, of course, resulted in a considerable loss of operating time and has hampered efficient, economical operation of this type of paper machine.

The present invention now provides an improved type of sealing means in which fluid pressure is employed to maintain a sealing ring in contact with the circular end faces of the cylinder mold. The use of a fluid pressure-urged sealing ring not only makes possible efficient initial sealing of the cylinder mold end faces but also makes possible continuous sealing of the machine by maintaining the sealing ring in contact with the mold even though the sealing ring may become worn.

The present invention comprises in general an arcuate mounting block for attachment to the interior side walls of a cylinder machine vat in a position adjacent the circular end faces of the

2

cylinder mold mounted therein. This arcuate mounting block is provided with a concentric groove in which the sealing ring is slidably mounted. An expansible tube connected to a suitable source of fluid, such as air, under pressure is bottomed in the groove to urge the sealing ring into contact with the circular end faces of the cylinder mold. Upon wear of the sealing ring, the tube is expanded by fluid pressure to maintain the sealing ring in contact with the end faces of the mold even though the sealing ring may be eroded by frictional losses caused during rotation of the mold.

It is, therefore, an important object of the present invention to provide an improved type of seal for a cylinder mold of a cylinder type paper machine, the sealing means being actuated by fluid pressure to maintain liquid-tight sealing contact with the circular end faces of the cylinder mold despite frictional wear of the sealing means itself.

Another important object of the present invention is to provide an improved seal for cylinder-type paper making machines in which a sealing ring is urged into contact with the circular end faces of a rotatable cylinder mold by means of fluid pressure.

A still further important object of the present invention is to provide an improved seal for a cylinder-type paper making machine comprising a mounting block adapted to be secured to the interior side wall surfaces of a cylinder paper making machine, the mounting block being provided with a groove concentric with a cylinder mold disposed within the vat, and a sealing ring disposed in the groove and urged toward the cylinder mold by fluid pressure, the seal ring being maintained in contact with the cylinder mold by fluid pressure despite frictional wear of the ring during operation of the machine.

Other and further important objects of this invention will be apparent from the disclosures in the specification and the accompanying drawings.

On the drawings:

Figure 1 is a vertical sectional view, with parts shown in elevation, of a cylinder-type paper making machine with the improved sealing means of the present invention;

Figure 2 is a fragmentary, enlarged elevational view of a side wall of a paper making machine having the cylinder mold removed and equipped with improved sealing means of the present invention;

Figure 3 is an enlarged, fragmentary, cross-sec-

3

tional view similar to Figure 1 illustrating in greater detail a portion of the sealing means of the present invention; and

Figure 4 is a fragmentary, enlarged, elevational view of a portion of the improved sealing means of the present invention.

As shown on the drawings:

In Figure 1, reference numeral 10 refers generally to a cylinder-type paper making machine including a vat 11 defined by side walls 12, end walls 13 and a bottom closure wall 14. A cylinder mold 15 is rotatably mounted within the vat 11 on shaft 16 extending axially through the mold 15 and packing rings 17 carried by side walls 12 into suitable journal boxes 18 adjacent each side wall 12. Shaft 16 is connected to a suitable source of power (not shown) for rotating cylinder mold 15 within vat 11. Each side wall 12 of vat 11 carries a drain box 19 for receiving the drainage from the interior of cylinder mold 15 and an outlet 20 for connection to an eductor fan for evacuating the interior of cylinder mold 15.

Cylinder mold 15 is provided with a foraminous or wire screen covered surface 21 supported by spiders 22 having radial arms 23 connected to the shaft 16. The end spiders 22 carry annular wear rings 24 removably secured thereto, as by recessed screws 25.

Adjacent each end of the cylinder mold 15, the vat side walls 12 are provided with an open topped slot 25 extending downwardly from the top of the vat and terminating in a rounded bottom 25a at a level above the drain boxes 19, as best shown in Figure 2. A removable wall portion 27 is mounted on each side wall 12 to cover the slot 26. The removable wall portion 27, fitting snugly within the slot 26, includes outlet 20 and carries packing ring 17, receiving shaft 16 therethrough. The upper portion 27a of removable wall 27 extends above the side walls 12 and carries at its upper end an arcuate ring segment 28 secured to portion 27a by suitable fastening means, such as bolts or screws 29. The arcuate segment 28 is concentric with cylinder mold 15 and carries an integral flange 30 (Figure 1) extending inwardly from side walls 12 toward the cylinder mold 15. This flange 30 aids in supporting the parallel edges of a conventional pick-up felt (not shown) contacting the mold 15.

As shown in Figures 1, 2 and 3, a fragmental ring or arcuate mounting block 31 is secured to the interior surface of each vat side wall 12 by suitable means, as by screws 32. Mounting block 31 is concentric with and of slightly smaller radius than cylinder mold 15.

The mounting block 31 is provided with an arcuate groove 33 concentric with the block 31 and opening toward cylinder mold 15. The bottom 33a of groove 33 is generally rounded for a purpose to be hereinafter more fully described.

An arcuate seal ring 34 of substantially rectangular cross-section is slidably retained in groove 33, the ring extending beyond the terminal edge of block 31 for contacting the ring 24 of cylinder mold 15 as best shown in Figure 3. An inflatable tube 35, formed of rubber, plastic, or other suitable non-porous flexible, expansible material, is mounted in the groove 33 and seated on the curved bottom 33a behind the seal ring 34.

The tube 35 is connected by means of elbow 36 to a suitable source of fluid, such as air, water and the like under pressure. As best shown in Figure 4, elbow 36 abuts closure plate 37 secured to the flat end surface 38a of enlarged terminal portion 38 of mounting block 31. One end of the

4

elbow 36 receives a nipple 39 extending into tube 35 and secured therein by means of wire or other suitable flexible fastening material wrapped about the surface of tube 35. A pipe or hose 41 attached to the other end of elbow 36 is connected to a suitable source of fluid under pressure as hereinbefore described.

The other end of tube 35, opposite that end secured to elbow 36, is closed, as shown in Figure 2, by means of closure plate 42 similar to plate 37 and carrying a second nipple extending into tube 35 and secured thereto by means as hereinbefore described.

As shown in dotted outline in Figure 3, the non-inflated tube 35 may be of generally circular cross-section. However, upon inflation of the tube, the tube becomes deformed as shown in Figure 3 to bear uniformly against sealing ring 33 to urge the sealing ring into sealing contact with the wear ring 24 of the cylinder mold 15. As the seal ring becomes worn by friction during rotation of the cylinder 15, the inflated tube 35 expands to urge the seal ring into close fitting sealing engagement with the wear ring 24. Thus, a positive seal is provided between the cylinder mold 15 and the vat walls 12 by the present invention and this seal is not broken by wear of the seal ring.

It will, of course, be understood that various details of construction may be varied through a wide range without departing from the principles of this invention and it is, therefore, not the purpose to limit the patent granted hereon otherwise than necessitated by the scope of the appended claims.

I claim as my invention:

1. A seal adapted for the end face of a paper making machine cylinder mold rotatably mounted in a vat, comprising an arcuate mounting block for attachment to an interior wall of said vat adjacent a mold end face to oppose the mold end face in concentric relation therewith, an arcuate round-bottomed groove formed in said block, a resilient sealing strip of rectangular cross-section slidably mounted in said groove, and an expansible tube originally of circular cross-section adapted to be connected to a source of fluid under pressure and snugly bottomed in said groove for urging said strip into contact with said mold end face, said tube being partially deformed from its original circular cross-section by its fluid pressure contact with said sealing strip and the expansion of said tube under pressure maintaining said strip in contact with said mold cylinder by sliding movement of said strip in said groove despite wear of the strip whereby the fluid pressure in said tube is uniformly applied via said strip throughout the contact area between said strip and said mold end face.

2. A seal adapted for sealing the circular end face of a paper making machine cylinder mold rotatably mounted in a vat, comprising a mounting block adapted for mounting on a wall of said vat adjacent said mold, said block having an arcuate groove therein with an arcuate closed end and an open end for facing said circular end of said mold in concentric relation therewith, a resilient sealing strip slidably mounted in said groove, and expansible means in extended surface engagement with said strip and snugly bottomed against the arcuate closed end of said groove, said means being connected to a source of fluid under pressure for urging said sealing

5

ring into contact with said mold whereby the fluid pressure in said expansible means is uniformly applied via said strip throughout the contact area between said sealing strip and said mold end face.

3. A seal adapted for sealing an open end face of a cylindrical mold rotatably mounted in a vat, comprising an annular wear ring adapted for detachable mounting on a circular end face of said mold, an arcuate mounting block adapted for attachment to an interior wall of said vat adjacent said mold end face, said block having an arcuate round-bottomed groove for concentric alignment with said mold end face, a resilient sealing strip slidably mounted in said groove and an expansible tube of originally circular cross-section connected to a source of fluid under pressure and bottomed in said groove in conforming contact with the bottom thereof behind said strip in extended contact therewith throughout the length of said groove for urging said strip into contact with said wear ring, the expansion of said tube under fluid pressure serving to maintain said strip in contact with said ring by sliding movement of said strip in said groove despite wear of said strip whereby the fluid pressure in said tube is uniformly applied via said strip throughout the contact area between said strip and said wear ring.

4. In a cylinder-type paper making machine having a cylinder mold rotatably disposed in a vat containing a pulp suspension, a seal disposed between the end faces of said mold and the adjacent side walls of said vat, comprising an arcuate mounting block for attachment to said vat side walls, said block having an arcuate groove formed therein, said groove having an arcuate bottom and an open end facing toward said mold, a resilient sealing strip of rectangular cross-section slidably mounted in said groove and extending therebeyond, and expansible means bottomed in said groove and contacting said strip throughout substantially the entire length thereof, said expansible means being in conforming arcuate contact with the bottom of said groove and in conforming plain contact with the inner face of said strip for urging said strip into resilient sealing engagement with the adjacent end face of said mold whereby the fluid pressure in said expansible means is applied uniformly via said strip throughout the contact area between said sealing strip and said mold end face.

6

5. A cylinder-type paper making machine comprising an open topped vat having opposed side walls, a cylinder mold rotatably disposed in said vat and having annular end faces in closely spaced relation to the inner faces of said side walls of said vat, an arcuate mounting block secured to the inner face of each of the side walls of said vat and having an arcuate round-bottomed groove therein opening inwardly toward the adjacent end face of said mold, an expansible tube originally of circular cross-section mounted in each of said grooves in conforming extended surface contact with the bottoms thereof and adapted to be connected to a source of fluid under pressure, and a resilient arcuate sealing strip of rectangular cross-section slidably received by each of said grooves and bottomed against said tube in surface engagement with substantially the entire length thereof, those portions of said tubes contacting said strips being deformed from their original circular cross-section into conformity with the adjacent side of said sealing strips and those portions of said tubes bottomed in said grooves retaining its original arcuate configuration, said strips being adapted to extend beyond said blocks into surface engagement with said mold end faces in sealing engagement therewith under fluid pressures exerted thereon by said expansible tubes with said fluid pressures and sliding movement of said tubes in said grooves maintaining said strips in sliding engagement with said end faces despite wear of said strips.

LLOYD HORNBOSTEL.

REFERENCES CITED

The following references are of record in the file of this patent:

UNITED STATES PATENTS

Number	Name	Date
1,166,882	Beaumont	Jan. 4, 1916
1,800,149	Miller et al.	Apr. 7, 1931
2,312,519	Berry	Mar. 2, 1943

FOREIGN PATENTS

Number	Country	Date
26,049	Great Britain	Nov. 10, 1909
421,020	France	Feb. 13, 1911
248,021	Germany	June 14, 1912
543,260	Germany	Feb. 3, 1932
656,453	Germany	Feb. 7, 1938