

(12) STANDARD PATENT
(19) AUSTRALIAN PATENT OFFICE

(11) Application No. **AU 2013209931 B2**

(54) Title
Piston for a needleless valve system

(51) International Patent Classification(s)
A61M 5/30 (2006.01) **A61M 39/22** (2006.01)
A61M 5/315 (2006.01)

(21) Application No: **2013209931** (22) Date of Filing: **2013.01.16**

(87) WIPO No: **WO13/109586**

(30) Priority Data

(31) Number	(32) Date	(33) Country
13/355,037	2012.01.20	US

(43) Publication Date: **2013.07.25**

(44) Accepted Journal Date: **2017.10.19**

(71) Applicant(s)
CareFusion 303, Inc.

(72) Inventor(s)
Panian, Tyler Devin;Yeh, Jonathan

(74) Agent / Attorney
FB Rice Pty Ltd, L 23 44 Market St, Sydney, NSW, 2000, AU

(56) Related Art
US 2007/0233046 A1
US 5203775 A
US 5749861 A
US D507447 S
US 5601207 A
US 2006/0276757 A1



- (51) International Patent Classification:
A61M 5/30 (2006.01) A61M 39/22 (2006.01)
A61M 5/315 (2006.01)
- (21) International Application Number:
PCT/US2013/021674
- (22) International Filing Date:
16 January 2013 (16.01.2013)
- (25) Filing Language: English
- (26) Publication Language: English
- (30) Priority Data:
13/355,037 20 January 2012 (20.01.2012) US
- (63) Related by continuation (CON) or continuation-in-part (CIP) to earlier application:
US 13/355,037 (CON)
Filed on 20 January 2012 (20.01.2012)
- (71) Applicant: CAREFUSION 303, INC. [US/US]; 3750 Torrey View Court, San Diego, California 92130 (US).
- (72) Inventors: PANIAN, Tyler Devin; 3490 Kemble Ave, Long Beach, California 90808 (US). YEH, Jonathan; 1323 Barberrry Drive, Diamond Bar, California 91765 (US).

- (74) Agents: GALLENSON, Mavis S. et al.; 5670 Wilshire Boulevard, Suite 2100, Los Angeles, California 90036 (US).
- (81) Designated States (unless otherwise indicated, for every kind of national protection available): AE, AG, AL, AM, AO, AT, AU, AZ, BA, BB, BG, BH, BN, BR, BW, BY, BZ, CA, CH, CL, CN, CO, CR, CU, CZ, DE, DK, DM, DO, DZ, EC, EE, EG, ES, FI, GB, GD, GE, GH, GM, GT, HN, HR, HU, ID, IL, IN, IS, JP, KE, KG, KM, KN, KP, KR, KZ, LA, LC, LK, LR, LS, LT, LU, LY, MA, MD, ME, MG, MK, MN, MW, MX, MY, MZ, NA, NG, NI, NO, NZ, OM, PA, PE, PG, PH, PL, PT, QA, RO, RS, RU, RW, SC, SD, SE, SG, SK, SL, SM, ST, SV, SY, TH, TJ, TM, TN, TR, TT, TZ, UA, UG, US, UZ, VC, VN, ZA, ZM, ZW.
- (84) Designated States (unless otherwise indicated, for every kind of regional protection available): ARIPO (BW, GH, GM, KE, LR, LS, MW, MZ, NA, RW, SD, SL, SZ, TZ, UG, ZM, ZW), Eurasian (AM, AZ, BY, KG, KZ, RU, TJ, TM), European (AL, AT, BE, BG, CH, CY, CZ, DE, DK, EE, ES, FI, FR, GB, GR, HR, HU, IE, IS, IT, LT, LU, LV, MC, MK, MT, NL, NO, PL, PT, RO, RS, SE, SI, SK, SM, TR), OAPI (BF, BJ, CF, CG, CI, CM, GA, GN, GQ, GW, ML, MR, NE, SN, TD, TG).

[Continued on next page]

(54) Title: PISTON FOR A NEEDLELESS VALVE SYSTEM

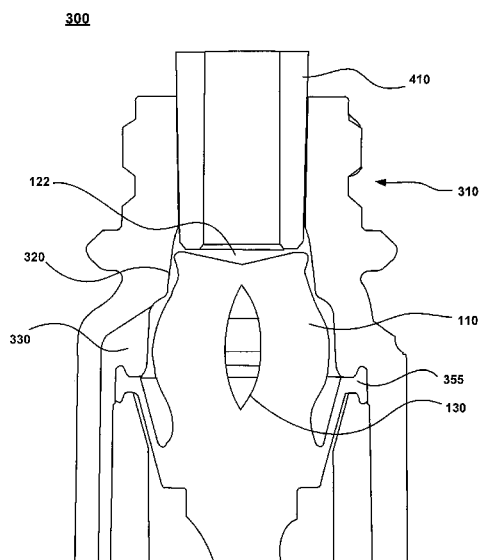

FIG. 4

(57) Abstract: A piston for a needleless valve system comprising a head portion configured to be disposed in the needleless valve system and controlling fluid flow through the needleless valve system. The head portion comprising a continuous top surface, and an opening disposed proximate the continuous top surface, wherein the continuous top surface is non-planar when the opening is in an open position.



Published:

— *with international search report (Art. 21(3))*

PISTON FOR A NEEDLELESS VALVE SYSTEM

PRIORITY

[0001] This Application is related to and claims priority to U.S. Serial Number 13/355,037 filed on January 20, 2012, entitled "PISTON FOR A NEEDLELESS VALVE SYSTEM," which is incorporated by reference herein.

BACKGROUND

[0002] Any discussion of the prior art throughout the specification should in no way be considered as an admission that such prior art is widely known or forms part of common general knowledge in the field.

[0003] Needleless devices or connectors are utilized as an alternative to hypodermic needles. Needleless connectors are utilized as fluid ports for a catheter attached to a patient. As a result of not using needles, needleless connectors reduce the risk of acquiring bloodborne diseases.

[0004] However, needleless connectors may contain surfaces and features that are difficult to clean. For example, some needleless connectors include a "split septum" (e.g., slit, cut, pathway, etc.) on a top surface of a piston or valve plug. Typically, the split septum is unable to be properly swabbed after use. Accordingly, pathogens may be present in the unsanitized areas which may lead to patient infection.

BRIEF DESCRIPTION OF THE DRAWINGS

[0005] Preferred embodiments of the invention will now be described, by way of example only, with reference to the accompanying drawings in which:

[0006] Fig. 1 illustrates an embodiment of a piston.

[0007] Fig. 2 illustrates an embodiment of a head portion of a piston.

[0008] Figs. 3 and 4 illustrate embodiments of a needleless valve system.

[0009] Fig. 5 illustrates an embodiment of a method for flow control in a needleless valve system.

[0010] The drawings referred to in this description should be understood as not being drawn to scale except if specifically noted.

SUMMARY

[0011] It is an object of the present invention to overcome or ameliorate at least one of the disadvantages of the prior art, or to provide a useful alternative.

[0012] One embodiment provides a piston for a needleless valve system comprising:

a head portion configured to be disposed in said needleless valve system and controlling fluid flow through said needleless valve system, said head portion comprising:

a continuous top surface; and

an opening disposed proximate to said continuous top surface, wherein said continuous top surface is non-planar when said opening is in an open position.

[0013] One embodiment provides a needleless valve system comprising:

a housing comprising a fluid port; and

a head portion disposed in said housing, wherein said head portion is configured for controlling fluid flow through said housing, said head portion comprising:

a continuous top surface; and

an opening disposed proximate to said continuous top surface, wherein said continuous top surface is non-planar when said opening is in an open position.

[0014] One embodiment provides a method for flow control in a needleless valve system, said method comprising:

sealing a port of a housing with a continuous top surface, wherein said continuous top surface is planar when said port is sealed, wherein a channel disposed proximate to said continuous top surface is compressed in a closed position;

depressing said continuous top surface by a needleless device;

opening said channel such that said continuous top surface is non-planar; and

in response to said opening said channel, allowing fluid to flow around said non-planar continuous top surface.

[0015] One embodiment provides a piston for a needleless valve system, the piston comprising:

a head portion configured to be disposed in said needleless valve system and controlling fluid flow through said needleless valve system, said head portion comprising:

a continuous top surface without a slit therethrough; and

an opening disposed proximate to said continuous top surface, wherein said continuous top surface is non-planar when said opening is in an open position.

[0016] One embodiment provides a needleless valve system comprising:

a housing comprising a fluid port; and

a head portion disposed in said housing, wherein said head portion is configured for controlling fluid flow through said housing, said head portion comprising:

- a continuous top surface without a slit therethrough; and
- an opening disposed proximate to said continuous top surface, wherein said continuous top surface is non-planar when said opening is in an open position.

[0017] One embodiment provides a piston for a needleless valve system, the piston comprising:

- a continuous top surface without a slit therethrough;
 - an opening disposed proximate to and separated from the top surface, the opening having an open position and a closed position; and
 - a spacer disposed in the opening,
- wherein the top surface is non-planar when the opening is in the open position.

[0018] One embodiment provides a piston for a needleless valve system, the piston comprising:

- a continuous top surface without a slit therethrough;
- an opening disposed proximate to and separated from the top surface, the opening having an open position and a closed position, wherein the open position comprises a relaxed state of the opening, and wherein the top surface is non-planar when the opening is in the open position.

[0019] One embodiment provides a piston for a needleless valve system comprising:

a head portion configured to be disposed in said needleless valve system and controlling fluid flow through said needleless valve system, said head portion comprising:

a continuous top surface; and

an opening disposed proximate to said continuous top surface, wherein said continuous top surface is non-planar when said opening is in an open position,

wherein said open position is a relaxed state of said opening.

[0020] One embodiment provides a method for flow control, the method comprising the step of:

connecting a needleless device to a port of a housing of a needleless valve system,

wherein the port is sealed by a piston having a continuous top surface without a slit therethrough, the top surface being proximate to the port and planar with a periphery that is in sealing contact with the port thereby sealing the port when no needleless device is connected to the port, and

wherein connection of a needleless device to the port displaces the top surface from the port thereby opening the port, and wherein the top surface is non-planar due to an opening that is proximate to and separated

from the top surface moving from a closed position to an open position when the top surface is displaced from the port.

[0021] One embodiment provides a piston for a needleless valve system, the piston comprising:

a head portion having a continuous top and compression features; and

the continuous top surface having an open configuration and a closed configuration, the top surface being substantially planar in the closed configuration and being non-planar in the open configuration,

wherein the compression features (i) are separated by an opening adjacent the top surface when in an open position; and (ii) are moved toward each other in a closed position, the compression features assuming the open position when unrestrained, and the closed position when the compression features are directed toward the opening; and

wherein the continuous top surface changes to the closed configuration when the compression features change to the closed position, and the open configuration when the compression features change to the open position.

[0022] One embodiment provides a needleless valve system comprising:

a housing comprising a fluid port; and

a piston disposed in said housing, the piston comprising a head portion having a continuous top surface and compression features, the

continuous top surface having an open configuration and a closed configuration, the top surface being substantially planar in the closed configuration and being non-planar in the open configuration;

wherein the compression features: (i) are separated by an opening adjacent the top surface when in an open position, and (ii) are moved toward each other in a closed position, the compression features assuming the open position when unrestrained, and the closed position when the compression features are directed toward the opening; and

wherein the continuous top surface changes to the closed configuration when the compression features change to the closed position, and the open configuration when the compression features change to the open position.

[0023] One embodiment provides a needleless valve system comprising:

a housing comprising a fluid port; and

a piston disposed in said housing, the piston having a head portion and configured to extend into the fluid port, the head portion comprising:

a continuous top surface having an open configuration, when the head portion does not extend into the fluid port, and a closed configuration, when the head portion extends into the fluid port, the top surface being substantially planar in the closed configuration and being non-planar in the open configuration; and

compression features (i) separated by an opening, positioned adjacent the top surface, when the top surface is in the open configuration; and (ii) directed toward each other when the top surface changes to the closed configuration.

[0024] One embodiment provides a piston for a needleless valve system, the piston comprising:

a continuous top surface without a slit therethrough; and

an opening disposed proximate to and separated from the top surface, wherein said continuous top surface is non-planar when said opening is in an open position.

[0025] One embodiment provides a needleless valve system comprising:

a housing comprising a fluid port; and

a piston disposed in said housing, the piston comprising:

a continuous top surface without a slit therethrough, the top surface having a periphery configured to sealingly mate with the fluid port to block flow through the fluid port; and

an opening disposed proximate to said continuous top surface, wherein said continuous top surface is non-planar when said opening is in an open position.

[0026] One embodiment provides a method for flow control in a needleless valve system, said method comprising:

connecting a needleless device to a port of a housing of a needleless valve system, wherein the port is sealed by a piston having a continuous top surface without a slit therethrough, the top surface being proximate to the port and planar with a periphery that is in sealing contact with the port thereby sealing the port when no needleless device is connected to the port, and wherein connection of a needleless device to the port displaces the top surface from the port thereby opening the port, and wherein the top surface is non-planar due to an opening that is proximate to and separated from the top surface moving from a closed position to an open position when the top surface is displaced from the port.

[0027] One embodiment provides a piston for a needleless valve system, the piston comprising:

- a continuous top surface without a slit therethrough;
- an opening disposed proximate to and separated from the top surface, the opening having an open position and a closed position, the open position comprises a relaxed state of the opening, wherein said continuous top surface is non-planar when said opening is in the open position.

[0028] A further embodiment of the invention provides a piston for a needleless valve system, the piston comprising:

- a continuous top surface without a slit therethrough;
- an opening disposed proximate to and separated from the top surface, said opening having an open position and a closed position, wherein

said continuous top surface is non-planar when said opening is in an open position; and
a spacer disposed in said opening.

[0029] A further embodiment of the invention provides a piston for a needleless valve system, the piston comprising:

a continuous top surface without a slit therethrough;
an opening disposed proximate to and separated from the top surface, the opening having an open position and a closed position, the open position comprising a relaxed state of the opening, wherein said continuous top surface is non-planar when said opening is in the open position.

[0030] A further embodiment of the invention provides a method for flow control in a needleless valve system, said method comprising:

connecting a needleless device to a port of a housing of a needleless valve system, wherein the port is sealed by a piston having a continuous top surface without a slit therethrough, the top surface being proximate to the port and planar with a periphery that is in sealing contact with the port thereby sealing the port when no needleless device is connected to the port, and wherein connection of a needleless device to the port displaces the top surface from the port thereby opening the port, and wherein the top surface is non-planar due to an opening that is proximate to and separated from the top surface moving from a closed position to an open position when the top

surface is displaced from the port, and wherein a spacer is disposed in the opening.

[0031] A further embodiment of the invention provides a needleless valve system comprising:

a housing comprising a fluid port;

a piston disposed in said housing, the piston comprising:

a continuous top surface without a slit therethrough, the continuous top surface having a periphery configured to sealingly mate with the fluid port to block flow through the fluid port; and

an opening disposed proximate to said continuous top surface, said opening having an open position and a closed position,

wherein said continuous top surface is non-planar when said opening is in said open position; and

a spacer disposed in said opening.

[0032] Unless the context clearly requires otherwise, throughout the description and the claims, the words “comprise”, “comprising”, and the like are to be construed in an inclusive sense as opposed to an exclusive or exhaustive sense; that is to say, in the sense of “including, but not limited to”.

DESCRIPTION OF EMBODIMENTS

[0033] Reference will now be made in detail to embodiments of the present technology, examples of which are illustrated in the accompanying drawings.

While the technology will be described in conjunction with various

embodiment(s), it will be understood that they are not intended to limit the present technology to these embodiments. On the contrary, the present technology is intended to cover alternatives, modifications and equivalents, which may be included within the spirit and scope of the various embodiments as defined by the appended claims.

[0034] Furthermore, in the following description of embodiments, numerous specific details are set forth in order to provide a thorough understanding of the present technology. However, the present technology may be practiced without these specific details. In other instances, well known methods, procedures, components, and circuits have not been described in detail as not to unnecessarily obscure aspects of the present embodiments.

[0035] Figure 1 depicts an embodiment of piston 100 which is configured to be disposed in a needleless valve system. The structure and function of the needleless valve system will be described in detail further below.

[0036] Piston 100 includes head portion 110 and base portion 150. In various embodiments, base portion 150 can be any physical structure that facilitates in head portion 110 controlling the flow of fluid through the needleless valve system. As such, base portion 150 is generically depicted as a simple square with dotted lines. Accordingly, the focus of the description herein will focus primarily on the structure and functionality of head portion 110 with respect to a needleless valve system.

[0037] Head portion 110 includes continuous top surface 120, opening 130 and compression features 140 and 141.

[0038] Continuous top surface 120 is configured to seal a port of a housing, which will be described in detail below. Continuous top surface 120 does not include (or does not require) any broken portions. For example, continuous top surface 120 is a continuous feature that does not include a slit, cut, hole, etc.

[0039] Continuous top surface 120 is a smooth surface. Accordingly, when continuous top surface 120 is swabbed, pathogens are readily removed and continuous top surface 120 is properly sanitized.

[0040] Continuous top surface 120 is non-planar in the relaxed state of head portion 110. This is based, in part, on opening 130 being in a relaxed open position, as depicted in Figure 1. A relaxed state is understood as the natural physical position of head portion 110 without any forces applied to head portion 110.

[0041] In one example, continuous top surface 120 includes non-planar configuration of a trough 122 in the relaxed state. It should be understood that the non-planar configuration can be any non-planar configuration that is conducive to allowing fluid flow around continuous top surface 120. Examples of non-planar configurations can be, but are not limited to, a concave surface, a valley, cavity, etc.

[0042] In one embodiment, head portion 110 is cylindrical. Thus, continuous top surface 120 is circular.

[0043] Opening 130 is disposed proximate continuous top surface 120. Opening 130 is in an open position when head portion 110 is in a relaxed state, as described above.

[0044] Opening 130 can be compressed to a closed position. For example, when head portion 110 is laterally compressed, then opening 130 is also laterally compressed to a closed position. In other words, the outer surface or walls of head portion is compressed inwards until opening 130 is closed. As a result, continuous top surface 120 is deformed into a planar surface.

[0045] Opening 130 can be any physical feature (e.g., hollow, void, channel, etc.) disposed in any orientation within head portion 110 and is able to resiliently open and close. Moreover, opening can be any shape that facilitates in allowing head portion 110 to deform such that continuous top surface 120 is deformed into a planar surface. For example, shapes of opening 130 can be, but is not limited to elliptical, oval, diamond, circle, etc.

[0046] Opening 130 is enclosed within head portion 110. For example, the periphery (or side surfaces) of opening 130 is fully enclosed within head portion 110.

[0047] In one embodiment, opening 130 is disposed along a diameter of head portion 110. In another embodiment, opening 130 is centrally disposed along a center axis of head portion 110. In various embodiments, opening 130 is disposed in any location that enables the deformation of continuous top surface 120.

[0048] Compression features 140 and 141 are disposed on the periphery of head portion 110. Compression features 140 and 141 are configured to facilitate in engaging with a housing such that opening 130 is compressed in a closed position.

[0049] In one embodiment, compression features 140 and 141 are bulges. It should be understood that compression features can be any physical features that facilitates in the engaging of a housing such that opening 130 is compressed in a close position.

[0050] Figure 2 depicts an embodiment of spacer 232 disposed in opening 130. Spacer 232 is configured to facilitate in the resilient opening of opening 130 from a closed position to an open position. Spacer 232 is depicted in a relaxed or natural position. However, spacer 232 can be fully compressed when opening 130 is in the closed position. It should be understood that spacer 232 can be any resiliently compressible material. Moreover, spacer 232 can be any shape disposed in any orientation within opening 130 to facilitate in the resilient opening of opening 130 from a closed position to an open position.

[0051] Figures 3 and 4 depict embodiments of needleless valve system 300. In general, needleless valve system 300 is configured to be coupled with medical devices (e.g., a catheter) and convey fluid without the use of a needle.

[0052] Needleless valve system 300 includes piston 100 disposed in housing 310. Housing 310 includes port 315, inner wall 320, and base 360.

[0053] Needleless valve system 300 is initially sealed, as depicted in Figure 3. In particular, piston 100 is seated in housing 310 such that port 315 is fluidly sealed by head portion 110. Additionally, the outer diameter of head portion 110 is compressed and seated within inner wall 320 to create a seal.

[0054] Opening 130 is compressed in a close position which results in continuous top surface 120 to be deformed into a planar surface. As a result, port 315 is sealed by continuous top surface 120 because the periphery of continuous top surface 120 mates with port 315.

[0055] In one embodiment, needleless valve system 300 is fluidly connected to a catheter. For example, female luer fitting 361 of base 360 is connected to a catheter. Accordingly, fluid flow is able to flow to/from the catheter.

[0056] Figure 4 depicts needleless valve system 300 in an open position due to tip 410 of a needleless syringe being inserted into needleless valve

system 300. Tip 410 displaces head portion 110 downward along inner wall 320. In one embodiment, housing 310 includes a male luer fitting 312 that corresponds to a female luer fitting of the syringe.

[0057] The diameter of inner wall 320 increases in the downward direction. Accordingly, the diameter of head portion 110 also increases when moving in the downward direction. Thus, opening 130 subsequently expands into its natural open position.

[0058] Moreover, continuous top surface 120 is deformed from planar to non-planar to create trough 122. Therefore, fluid is able to flow around continuous top surface 120 via trough 122 to volume 330. The fluid then flows from volume 330 through base 360 to a medical device, such as a catheter.

[0059] In one embodiment, fluid is able to flow in the opposite direction. For example, blood flows from a patient into volume 330 around continuous top surface 120 via trough 122 and into the syringe.

[0060] In various embodiments, it should be appreciated that needleless valve system 300 can allow positive and/or negative fluid displacement.

[0061] Piston 100 is an elastic body. As such, piston 100 is able to deform back to its original position such that head portion 110 is pushed up through

inner wall 320. Accordingly, head portion is compressed against inner wall 320 and port 315 is subsequently sealed.

[0062] In particular, base portion 350 acts as a spring to facilitate in opening 130 deforming to a closed position and head portion 110 resealing port 315. For example, base portion 350 includes a tail that resiliently deforms to its original position in response to tip 410 being removed from housing 310. The spring force of base portion 350 causes head portion 110 to move upward within inner wall 320 and head portion 110 is compressed within inner wall 320. As a result, opening 310 is deformed into a closed position and continuous top surface 120 is deformed into a planar surface. Moreover, the spring force of the diaphragm 355 also causes head portion 110 to move in and be compressed within inner wall 320.

[0063] Additionally, compression features 140 and 141 (e.g., bulges) enhance the compression of head portion 110 within housing 310. Compression features 140 and 141 increase the diameter of head portion 110 and thus, increase the forces applied on head portion 110 to close opening 130.

[0064] It should be appreciated that base portion 350 can include any elastic feature for generating a spring force to translate head portion 110 within inner wall 320 such that port 315 is resealed.

[0065] In various embodiments, a base portion (e.g., base portion 150 or base portion 350) can include any combination of a tale and/or a diaphragm. In one embodiment, a base portion does not include a tale and/or a diaphragm.

[0066] Oftentimes pathogens may be present on or around continuous top surface 120 after tip 410 of the syringe is removed from needleless valve system 300. However, the pathogens are easily swabbed away from the smooth continuous top surface. Therefore, the risk of patient infection is reduced.

[0067] Figure 5 depicts an embodiment of a method 500 for controlling fluid flow. In some embodiments, method 500 is performed at least by needleless valve system 300, as depicted in Figures 3 and 4.

[0068] At 510 of method 500, a port of a housing is sealed with a continuous top surface. The continuous top surface is planar when the port is sealed, and a channel disposed proximate continuous top surface is compressed in a closed position. For example, port 315 is fluidly sealed with continuous top surface 120 when continuous top surface 120 is planar. Moreover, opening 130 (e.g. a channel) is disposed proximate continuous top surface 120 and is collapsed or compressed.

[0069] At 520, the continuous top surface is depressed by a needleless device. For example, continuous top surface 120 is depressed down through housing 310 by tip 410 of a needleless syringe.

[0070] At 530, the channel is opened such that the continuous top surface is non-planar. For example, when head portion 110 slides down through housing 310, opening 130 expands to a natural open position.

[0071] At 540, in response to the opening the channel, fluid is allowed to flow around the non-planar continuous top surface. For example, opening 130 expands to a natural open position which causes continuous top surface 120 to bend or fold to create trough 122. As a result, fluid is allowed to flow around non-planar continuous top surface 120 through housing 310.

[0072] At 550, fluid is injected through the port via the needleless device. For example, medicine is injected through port 315 via a fluid channel of tip 410 of a needleless syringe.

[0073] At 560, the port is resealed with the continuous top surface in response to removing the needleless device from the port. For example, tip 410 is removed from housing 310. In response, as head portion 110 is compressed within inner wall 320, opening 130 is compressed to a closed position and continuous top surface 120 is deformed to a planar state and thus, port 315 is fluidly sealed.

[0074] Various embodiments of the present invention are thus described.

While the present invention has been described in particular embodiments, it should be appreciated that the present invention should not be construed as limited by such embodiments, but rather construed according to the following claims.

[0075] All elements, parts and steps described herein are preferably included. It is to be understood that any of these elements, parts and steps may be replaced by other elements, parts and steps or deleted altogether as will be obvious to those skilled in the art.

[0076] CONCEPTS

This writing discloses at least the following concepts.

Concept 1. A piston for a needleless valve system comprising:

a head portion configured to be disposed in said needleless valve system and controlling fluid flow through said needleless valve system, said head portion comprising:

a continuous top surface; and

an opening disposed proximate to said continuous top surface, wherein said continuous top surface is non-planar when said opening is in an open position.

Concept 2. The piston of Concept 1, wherein said continuous top surface is configured to be planar when said opening is in a closed position.

Concept 3. The piston of Concept 1 or 2, wherein said continuous top surface comprises a depression when said opening is in said open position.

Concept 4. The piston of Concept 1, 2, or 3 wherein said continuous top surface does not require a slit.

Concept 5. The piston of any one of the preceding concepts wherein said opening is enclosed in said head portion.

Concept 6. The piston of any one of the preceding concepts, wherein said opening is disposed along a diameter of said head portion.

Concept 7. The piston of any one of the preceding concepts, wherein said opening is oval-like.

Concept 8. The piston of any one of the preceding concepts, further comprising:

a spacer disposed in said opening.

Concept 9. The piston of any one of the preceding concepts, further comprising:

a compression feature disposed along a circumference of said head portion.

Concept 10. The piston of Concept 9, wherein said compression feature is a bulge.

Concept 11. The piston of any one of the preceding concepts, wherein said open position is a relaxed state of said opening.

Concept 12. A needleless valve system comprising:

a housing comprising a fluid port; and

a head portion disposed in said housing, wherein said head portion is configured for controlling fluid flow through said housing, said head portion comprising:

a continuous top surface; and

an opening disposed proximate to said continuous top surface, wherein said continuous top surface is non-planar when said opening is in an open position.

Concept 13. The needleless valve system of Concept 12, wherein said housing is configured to engage with a needleless syringe.

Concept 14. The needleless valve system of Concept 12 or 13, wherein said housing is further configured to be fluidly connected with a catheter.

Concept 15. The needleless valve system of any one of concepts 12-14, wherein said port is not fluidly sealed when said continuous top surface is non-planar.

Concept 16. The needleless valve system of any one of concepts 12-15, wherein said port is fluidly sealed when said continuous top surface is in a planar position.

Concept 17. The needleless valve system of any one of concepts 12-16, wherein said continuous top surface does not require a slit.

Concept 18. The needleless valve system of any one of concepts 12-17, wherein said opening is enclosed in said head portion.

Concept 19. The needleless valve system of any one of concepts 12-18, wherein said opening is disposed along a diameter of said head portion.

Concept 20. The needleless valve system of any one of concepts 12-19, further comprising:

a spacer disposed in said opening.

Concept 21. The needleless valve system of any one of concepts 12-20, further comprising:

a compression feature disposed along a circumference of said head portion.

Concept 22. The needleless valve system of Concept 21, wherein said compression feature is a bulge.

Concept 23. A method for flow control in a needleless valve system, said method comprising:

sealing a port of a housing with a continuous top surface, wherein said continuous top surface is planar when said port is sealed, wherein a channel disposed proximate to said continuous top surface is compressed in a closed position;

depressing said continuous top surface by a needleless device;

opening said channel such that said continuous top surface is non-planar; and

in response to said opening said channel, allowing fluid to flow around said non-planar continuous top surface.

Concept 24. The method of Concept 23, further comprising:
injecting fluid through said port via said needleless device.

Concept 25. The method of Concept 23 or 24, further comprising:
resealing said port with said continuous top surface in response to removing said needleless device from said port.

Claims:

1. A piston for a needleless valve system, the piston comprising:
a continuous top surface without a slit therethrough;
an opening disposed proximate to and separated from the top surface, said opening having an open position and a closed position, wherein said continuous top surface is non-planar when said opening is in an open position; and
a spacer disposed in said opening.
2. The piston of claim 1, wherein said continuous top surface is planar when said opening is in said closed position.
3. The piston of claim 1, wherein said continuous top surface comprises a depression when said opening is in said open position.
4. The piston of any one of the preceding claims, further comprising a head portion, wherein said opening passes through the head portion.
5. The piston of any one of claims 1 to 3, wherein said opening is disposed along a diameter of said head portion.
6. The piston of any one of claims 1 to 3, wherein said opening is oval-like.
7. The piston of any one of the preceding claims, further comprising:
a compression feature disposed along a circumference of said head portion.
8. The piston of claim 7, wherein said compression feature is a bulge.
9. The piston of any one of the preceding claims, wherein said open position is a relaxed state of said opening.

10. A needleless valve system comprising:
 - a housing comprising a fluid port;
 - a piston disposed in said housing, the piston comprising:
 - a continuous top surface without a slit therethrough, the continuous top surface having a periphery configured to sealingly mate with the fluid port to block flow through the fluid port; and
 - an opening disposed proximate to said continuous top surface, said opening having an open position and a closed position, wherein said continuous top surface is non-planar when said opening is in said open position; and
 - a spacer disposed in said opening.
11. The needleless valve system of claim 10, wherein said housing is configured to engage with a needleless syringe.
12. The needleless valve system of claim 10, wherein said housing is further configured to be fluidly connected with a catheter.
13. The needleless valve system of any one of claims 10 to 12, wherein said port is not fluidly sealed when said continuous top surface is non-planar.
14. The needleless valve system of any one of claims 10 to 12, wherein said port is fluidly sealed when said continuous top surface is in a planar position.
15. The needleless valve system of any one of claims 10 to 14, further comprising a head portion, wherein said opening passes through said head portion.
16. The needleless valve system of any one of claims 10 to 14, wherein said opening is disposed along a diameter of said head portion.
17. The needleless valve system of any one of claims 10 to 16, further comprising:

a compression feature disposed along a circumference of said head portion.

18. The needleless valve system of claim 17, wherein said compression feature is a bulge.

19. A method for flow control in a needleless valve system, said method comprising:

connecting a needleless device to a port of a housing of a needleless valve system, wherein the port is sealed by a piston having a continuous top surface without a slit therethrough, the top surface being proximate to the port and planar with a periphery that is in sealing contact with the port thereby sealing the port when no needleless device is connected to the port, and wherein connection of a needleless device to the port displaces the top surface from the port thereby opening the port, wherein the top surface is non-planar due to an opening that is proximate to and separated from the top surface moving from a closed position to an open position when the top surface is displaced from the port, and wherein a spacer is disposed in the opening.

20. The method of claim 19, further comprising:

allowing fluid to flow from the needleless device into the port and around the displaced and non-planar top surface.

21. The method of claim 19 or claim 20, further comprising:

removing the needleless device from the port thereby allowing the top surface to return to a position proximate to the port, thereby sealing the port.

22. A piston for a needleless valve system, the piston comprising:

a continuous top surface without a slit therethrough;

an opening disposed proximate to and separated from the top surface, the opening having an open position and a closed position, the open position comprising a relaxed state of the opening, wherein said continuous top surface is non-planar when said opening is in the open position.

23. A needleless valve system comprising:
a housing comprising a fluid port; and
a head portion disposed in said housing, wherein said head portion is configured for controlling fluid flow through said housing, said head portion comprising:
a continuous top surface without a slit therethrough; and
an opening disposed proximate to said continuous top surface, wherein said continuous top surface is non-planar when said opening is in an open position.
24. A piston for a needleless valve system, the piston comprising:
a continuous top surface without a slit therethrough;
an opening disposed proximate to and separated from the top surface, the opening having an open position and a closed position, wherein the open position comprises a relaxed state of the opening, and wherein the top surface is non-planar when the opening is in the open position.

1/5

100

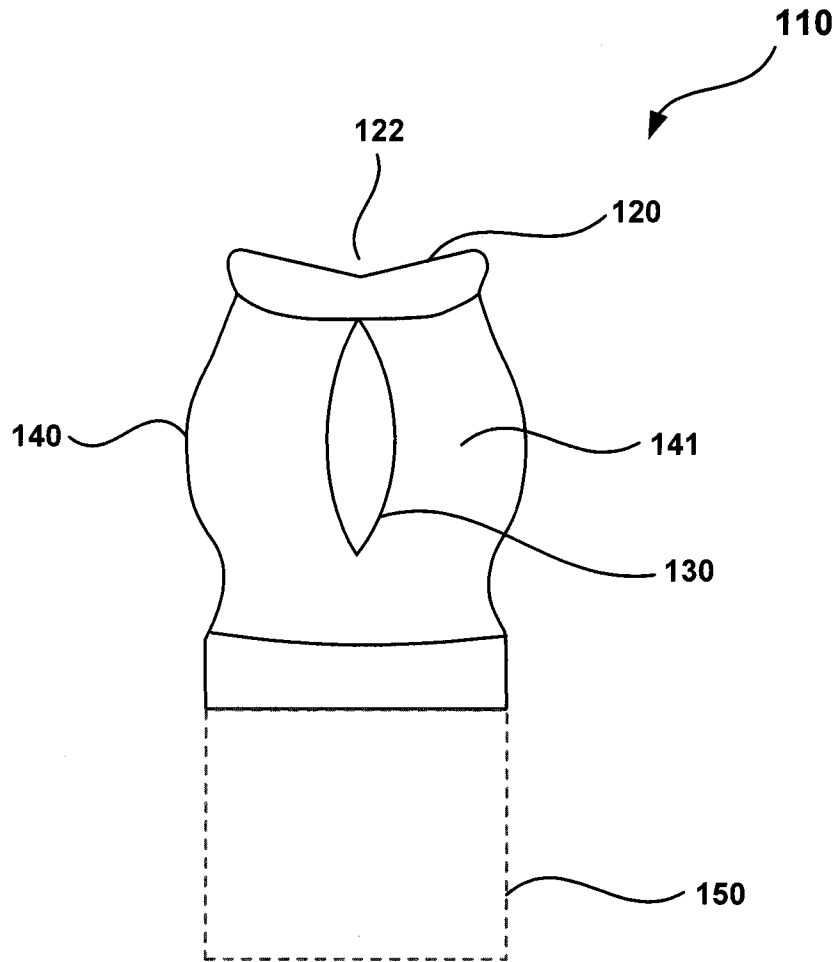

FIG. 1

2/5

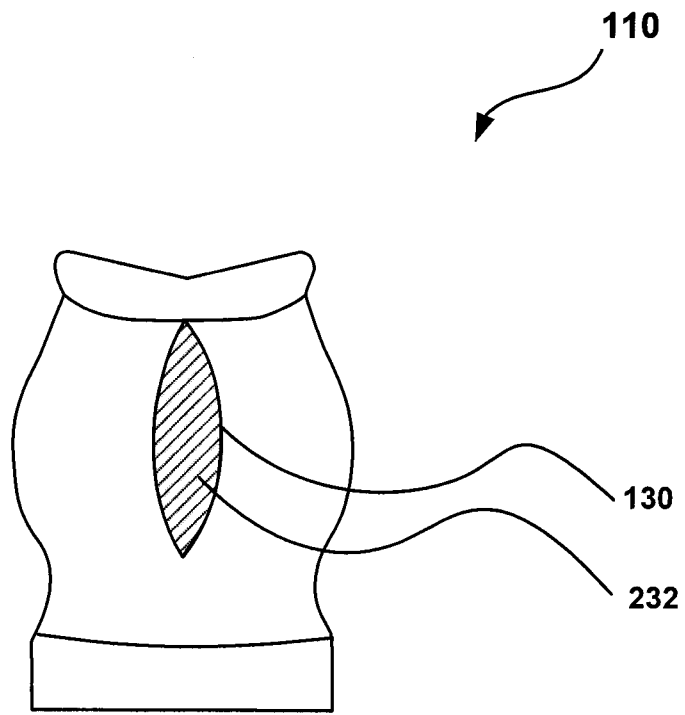

FIG. 2

3/5

300

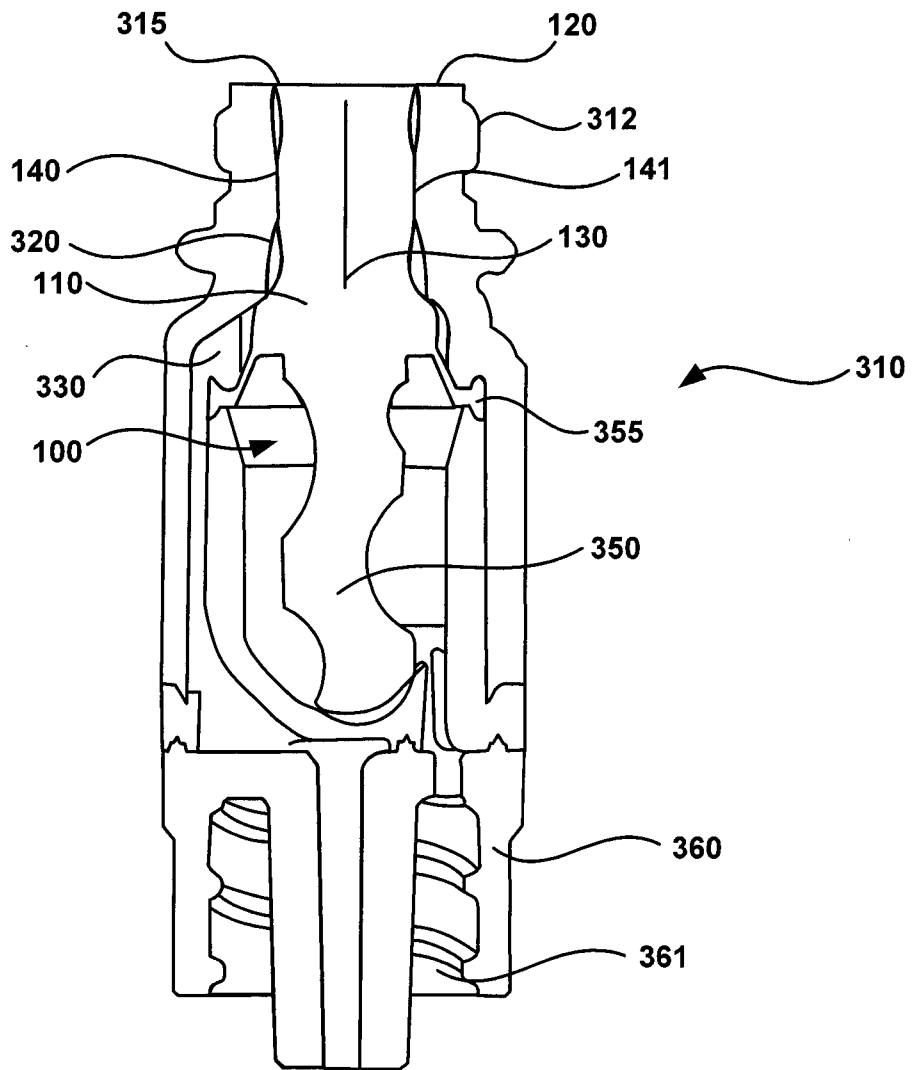

FIG. 3

4/5

300

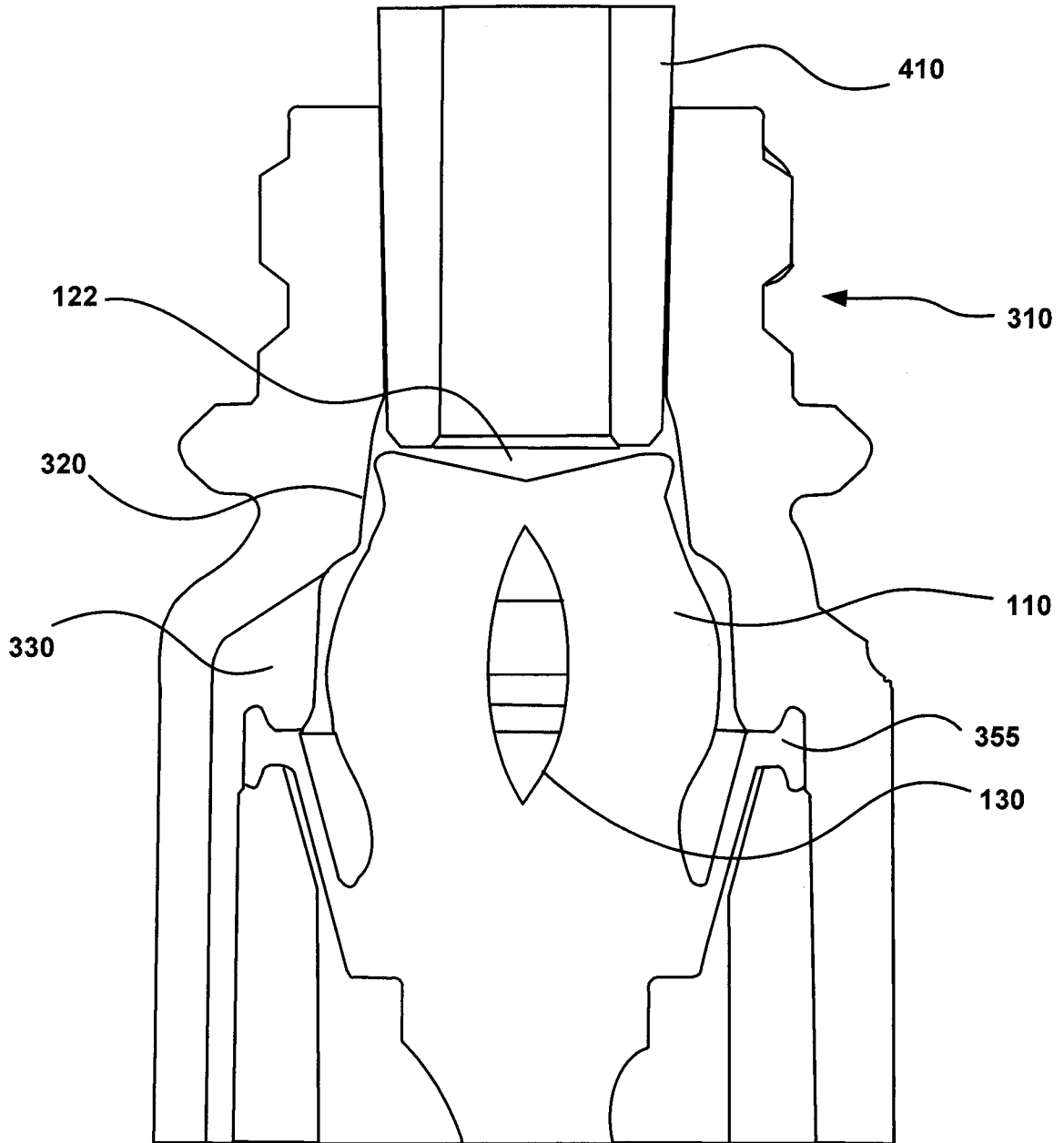

FIG. 4

5/5

500

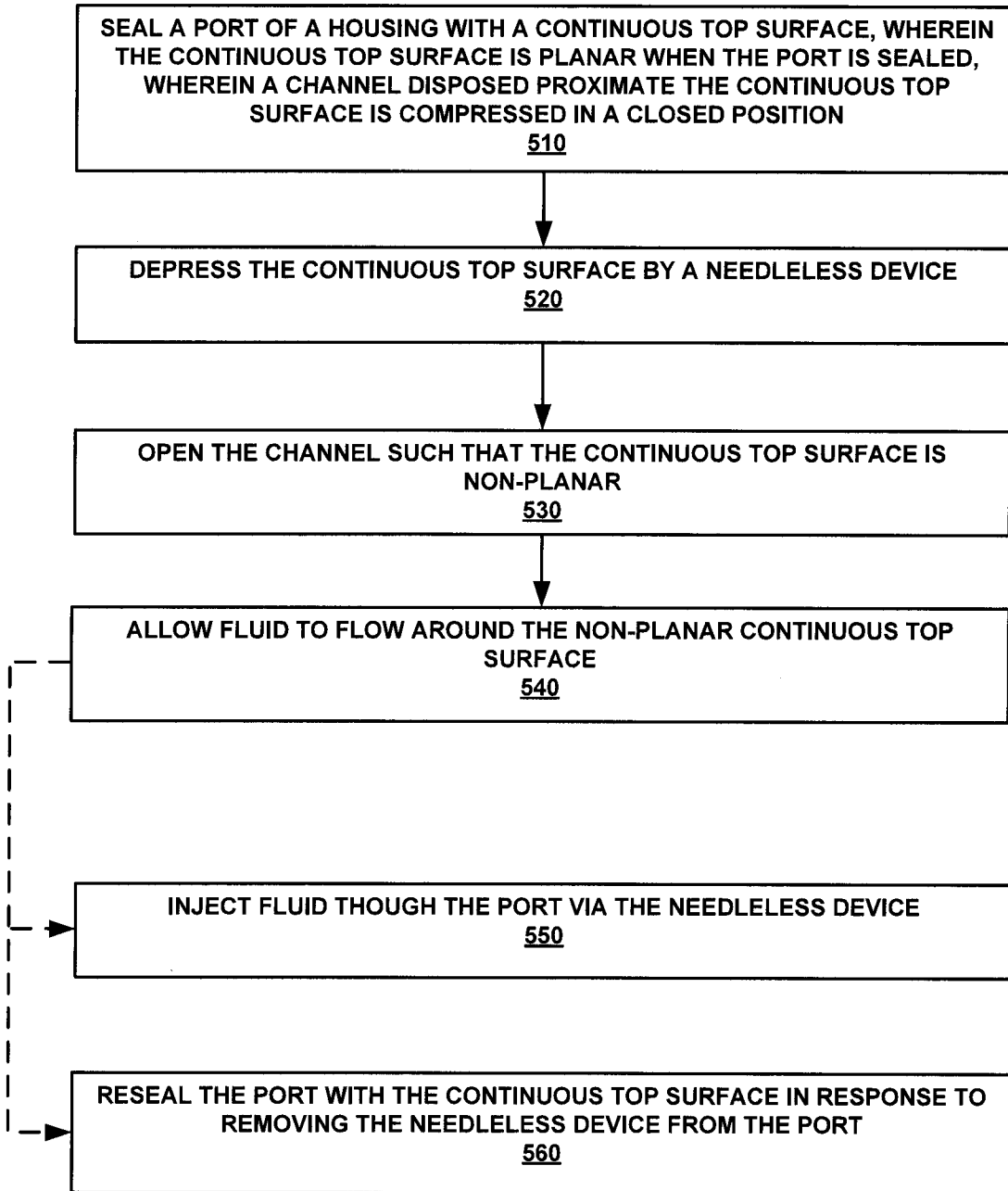

FIG. 5