

No. 615,302.

Patented Dec. 6, 1898.

W. H. PAGE.
STOVE.

(Application filed Aug. 25, 1897.)

(No Model.)

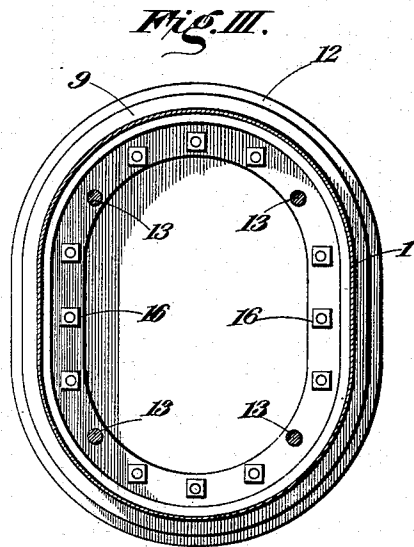
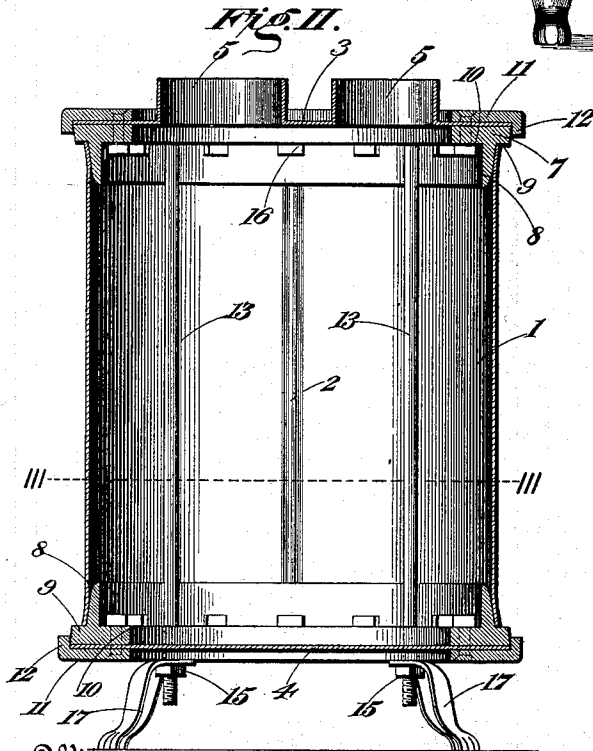
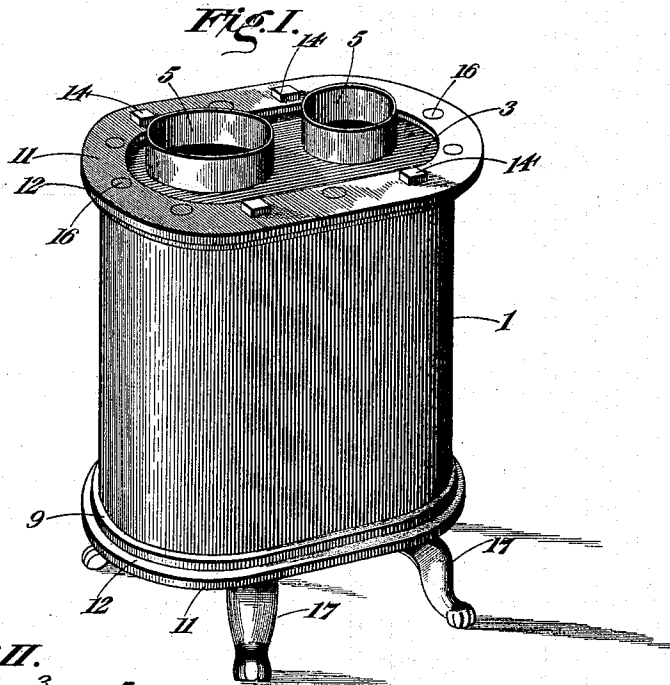

Witnesses:

M. C. Fowler
Chester A. Baker

Inventor:

William H. Page
By Joseph L. Curtis
Attorney

UNITED STATES PATENT OFFICE.

WILLIAM H. PAGE, OF BASIC CITY, VIRGINIA.

STOVE.

SPECIFICATION forming part of Letters Patent No. 615,302, dated December 6, 1898.

Application filed August 25, 1897. Serial No. 649,486. (No model.)

To all whom it may concern:

Be it known that I, WILLIAM H. PAGE, of Basic City, in the county of Augusta, State of Virginia, have invented certain new and useful Improvements in Stoves, of which the following is a complete specification, reference being had to the accompanying drawings.

My invention relates to stoves of that class commercially known as "air-tight" stoves; and its object is to produce a stove the parts of which may be readily assembled or disassembled when required without the employment of a skilled mechanic, whereby the stove may be packed and shipped in the "knocked-down" state at a material saving in the cost of transportation and whereby when burned out parts can be renewed with facility and at comparatively trifling cost.

Stoves of the class to which my invention belongs are generally put together by the aid of seams or joints, which, it being impossible to reseat such work, become altogether useless when any part of the body or shell is burned out. In my stove all permanent seams or joints are dispensed with, there being but one seam—namely, the vertical seam in the side of the sheet-metal body part. This seam may be united by a removable lock or can, if desired, be formed by any worker in sheet metal.

In the accompanying drawings, Figure I is a perspective view of my stove complete. Fig. II is a central vertical sectional view of the same. Fig. III is a section on the line III III of Fig. II.

Referring to the figures on the drawings, 1 indicates the body part of my stove, which is preferably composed of a single piece of sheet metal bent and united at its ends by a suitable seam 2. The body part may be of any suitable shape and dimensions and is designed to be united, as to its opposite ends, to a top or top plate 3 and a bottom or bottom plate 4. The top plate, as illustrated, is provided with the usual apertures 5—for example, one for the introduction of fuel and the other for the attachment of a smoke-flue or stove-pipe.

The top and bottom plates which I prefer to employ are preferably united to the body 1 by interchangeable elements or end members—that is to say, by members which may be used for uniting the top plate or the bot-

tom plate to the body part 1. The members which I prefer to employ for uniting the top and bottom plates, respectively, to the body part consist of a ring 7, provided upon one side with a flange 8, preferably slightly beveled upon its outer surface. The flange is located between the opposite edges of the ring 7, defining in its respective angles of juncture with the ring 7 upon the outer side a rim or margin 9 and upon the inner side a rim 10 for the accommodation of binding members to be described.

11 indicates a ring similar in shape to the ring 7, but provided with an overlapping flange 12, which when the two rings are united overlaps the edge of the ring 7 and, fitting snugly around the outer edge thereof, forms therewith a close joint.

13 indicates binding members, consisting, preferably, of rods extending from end to end through the stove and through the rings 7 and 11 at the opposite ends thereof. The rods 13 are provided at one end, respectively, with heads 14 and at the other end are threaded to receive nuts 15. The tension of the nuts upon the rods 13 serves at once to firmly clamp the top plate 3 and bottom plate 4 between their respective rings 7 and 11 and also to force the body part 1 upon the flanges 8 against the respective rims 9. By this means a tight joint is formed between the body part, the top and bottom plates, respectively, and the rings that unite them.

In addition to the rods 13 a crown of bolts 16 may be employed, as illustrated, for uniting the top and bottom plates, respectively, with the rings 7 and 11 and perfecting the joints between them.

In the drawings I show legs 17, united by the nuts 15 to the rods 13; but the legs may be secured in place in any usual and ordinary manner.

I have described the members 7 and 11 as rings; but they may be of any suitable shape and are, as illustrated, oblong or elliptical rings.

In practice in uniting the parts together the rings 7 and 11 for the top and bottom plates, with the intermediate plates 3 and 4, may be united by the bolts 16. Afterward all that is necessary is to place the body part 1 over the opposite flanges 8, insert the rods

13 into the holes provided for them, and screw up the nuts 15 until the joints between the body part and its top and bottom plates, respectively, are perfected.

5 It is obvious that if the sheet-metal body part, top, or bottom is burned out it can be renewed by removal of the rods 13 and the bolts 16, if necessary, and when renewed the several members may be united as above specified.
10

What I claim is—

1. In a stove, the combination with a body part, and flanged rings, of top and bottom plates, additional rings for clamping the top and bottom plates to the flanged rings, respectively, and binding members, substantially as and for the purpose specified.
15

2. In a stove, the combination with a body part, of rings provided with flanges having inclined faces designed to extend into the opposite ends of the body part, top and bottom plates imposed upon said rings, additional rings for clamping the top and bottom plates to the flanged rings, means for securing each flanged ring to the adjacent end plate and clamping ring, and means common to the end
25

members formed by each flanged ring, end plate and clamping-ring for urging the inclined flanges into the opposite ends of the body part, substantially as specified. 30

3. In a stove, the combination with a body part, and flanged rings, of top and bottom plates, additional rings, provided with overlapping flanges, for clamping the top and bottom plates to the flanged rings, respectively, and binding members, substantially as and for the purpose specified. 35

4. In a stove, the combination with a body part, of end members composed, respectively, of a pair of rings, one of which is flanged, and an intermediate end plate, of means for securing the elements of each end member in their proper relative positions, and binding members adapted to urge the end members against the ends of the body part, substantially as specified. 45

In testimony of all which I have hereunto subscribed my name.

WILLIAM H. PAGE.

Witnesses:

J. E. COOKE,

J. F. TEMPLETON.