

Dec. 6, 1938.

W. V. DERBY

2,139,578

VENDING MACHINE

Filed Dec. 30, 1936

2 Sheets-Sheet 1

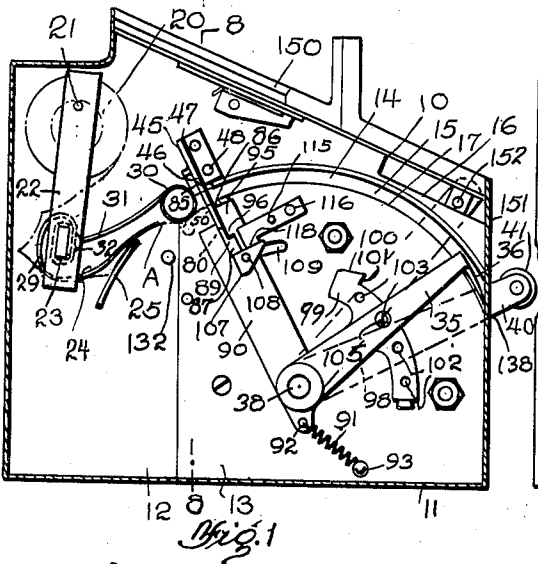

Fig. 1

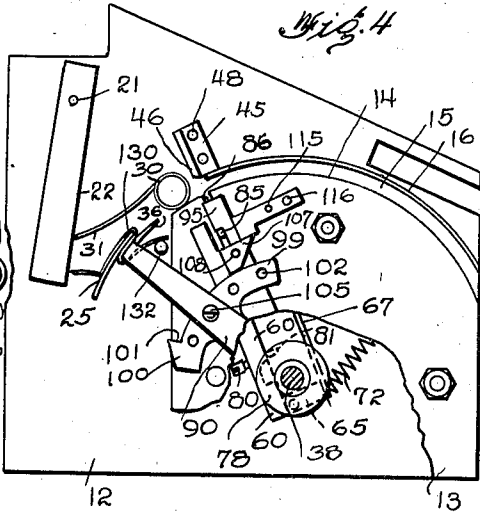

Fig. 4

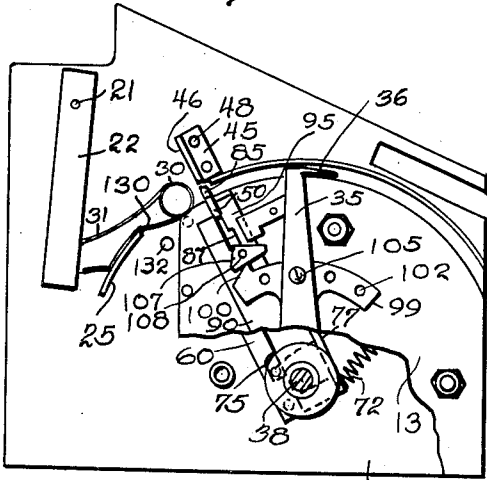

Fig. 2

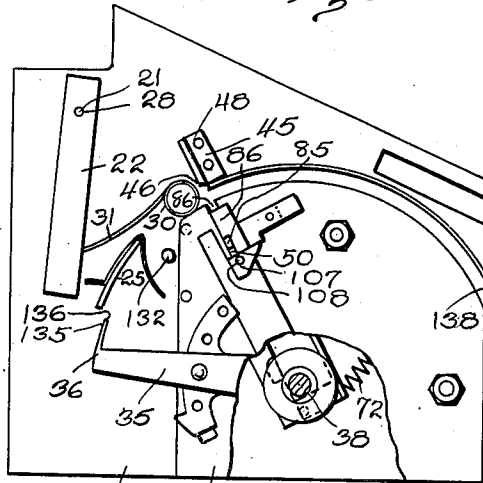

Fig. 5

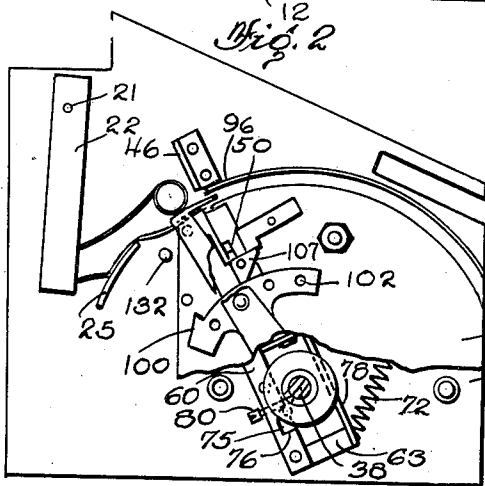

Fig. 3

Inventor
William V. Derby

Harold Straus

Attorney

Dec. 6, 1938.

W. V. DERBY

2,139,578

VENDING MACHINE

Filed Dec. 30, 1936

2 Sheets-Sheet 2

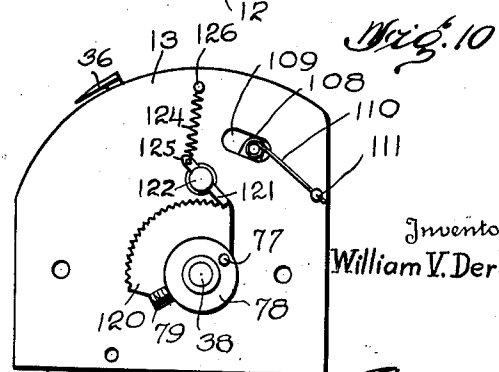
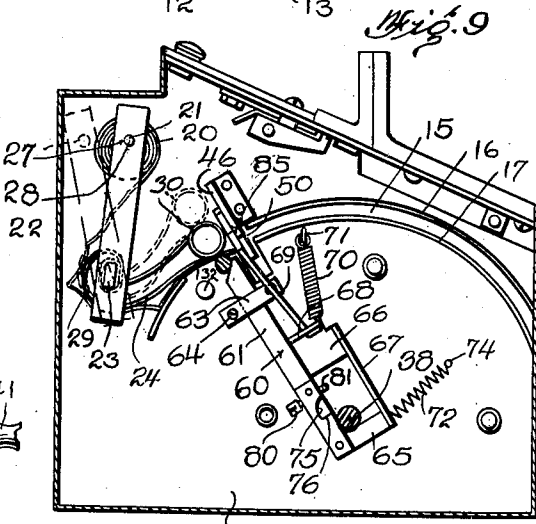
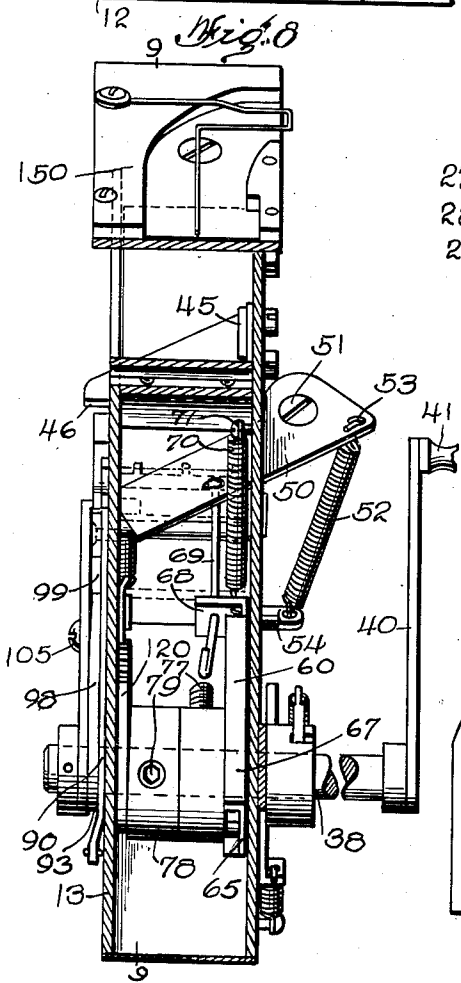
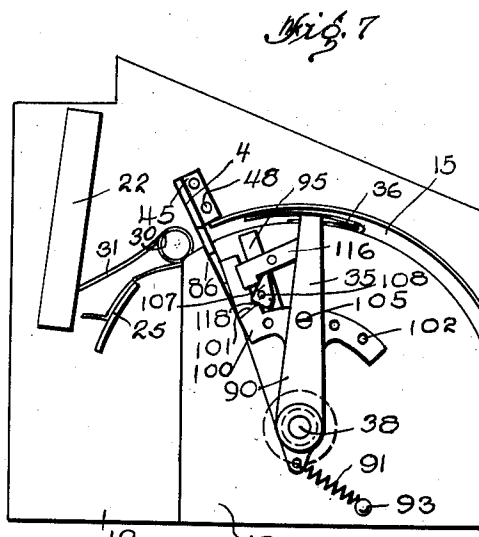
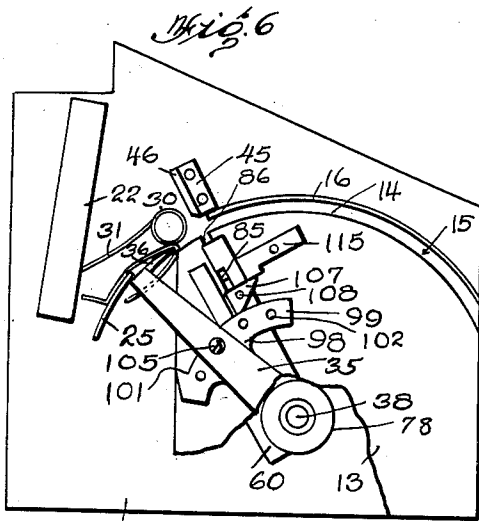

Inventor
William V. Derby

David Stearns
Attorney

UNITED STATES PATENT OFFICE

2,139,578

VENDING MACHINE

William V. Derby, Baltimore, Md., assignor to The
General Vending Service Co., Baltimore, Md.,
a partnership of Maryland

Application December 30, 1936, Serial No. 118,378

21 Claims. (Cl. 164—48)

This invention relates to web feeding, cutting, and delivering mechanisms, and more particularly to mechanisms of this type which are adapted to be employed in connection with, or to be embodied in, devices for vending or delivering postage stamps, coupons, tickets or the like.

The general object of the invention is to provide a novel and improved device of this character which is of simple and compact construction and which is marked by ease and accuracy of operation.

A more specific object of the invention is the provision, in a device of this character, of a novel oscillating feeding and delivery member which is adapted to be moved in opposite directions; a reverse or rearward movement being given the member for effecting certain preliminary settings of the cooperating cutting mechanism and certain manipulations of the leading end of the web, and then a forward movement being given the member for feeding the web, tripping the cutter and delivering the severed portion of the web.

Another object of the invention is to provide novel means cooperating with the oscillating feeder member for attaining a more secure and positive feeding connection between the web and the feeder member, this connection being effected by folding back the leading end of the web to provide a crease for engagement by the feeding member during its forward feeding stroke.

Further objects include the provision of novel and improved means for retracting the web severing instrumentality during the preliminary rearward movement of the feeding member, means for retaining the instrumentality in its retracted position, and means for tripping or releasing the web severing member to effect the severance of the web at a predetermined point during the forward movement of the feeder; the point at which the web cutting member is tripped being variable to permit the selective severing and delivering of different lengths of the web.

A still further object of the invention is the provision of novel releasable web roll supporting and retaining means embodying resilient pressing and guiding means for directing the web through the device and positioning its successive forward edges in position for engagement by the folding and feeding mechanism.

Other objects and features of novelty will be apparent from the following specification when read in connection with the accompanying drawings in which one embodiment of my invention is illustrated by way of example.

In the drawings:

Figure 1 is a view in side elevation of a stamp vending device embodying the principles of my invention;

Figures 2, 3, 4, 5, 6 and 7 are similar somewhat diagrammatic views showing successive positions of the webfeeding mechanism during the operation of the device to seize, feed, cut, and deliver a portion of the web or strip of stamps;

Figure 8 is a vertical, transverse sectional view of the device taken substantially on line 8—8 of Figure 1;

Figure 9 is a vertical longitudinal sectional view taken on line 9—9 of Figure 8 and looking in the direction of the arrows; and

Figure 10 is a vertical longitudinal sectional view, on a somewhat reduced scale, taken on line 10—10 of Figure 8, and looking in the direction of the arrows associated with said line.

The device comprising the preferred embodiment of my invention as set forth in the present specification and illustrated in the drawings, is designated generally by the numeral 10 in the drawings, and is adapted to be enclosed in various types of casings and associated with various other devices, such as check-controlled mechanisms or apparatus for delivering or dispensing stamps, tickets, coupons, or other articles in strip or sheet form. In the present case the device is applied to a stamp vending machine which is coin- or check-controlled and may be contained in a casing or housing, a portion of which is shown at 11.

The mechanism which forms the particular subject of the present invention is enclosed and supported by the two side plates 12 and 13, plate 12 being, in this instance, somewhat larger than the parallel plate 13. Plate 13 is provided with an arcuate upper edge 14 which conforms to the shape of the feed slot 15 formed between the arcuate upper and lower guide strips 16 and 17. The lower guide strip 17 is secured in any suitable manner between the two plates 12 and 13, while the upper strip 16 is carried by the plate 12. The two side plates 12 and 13 are spaced apart, as shown in Figure 8, a distance which is slightly greater than the width of the web to be fed, cut, and delivered.

The web supply in this case comprises a spool or roll 20 which is supported upon the pin or post 21 projecting from the plate 12. A bracket 22 is rigidly secured upon the end of a shaft 23 which is rotatably mounted in the plate 12 and which also carries a curved flat spring plate 24 which serves to guide the web and press it firmly against the arcuate plate 25 which is also carried by the side

plate 12. The bracket 22 is provided with an opening 27 which is adapted to be sprung over the reduced end 28 of the pin 21 when the device is in operative position. The bracket and spring plate assembly is adapted to be moved to the position shown in dotted lines in Figure 9 of the drawings, when a new roll 20 is to be applied and in order to permit the leading end of the web to be threaded up. This forward end of the web designated A is brought around the curved or rolled portion 29 of the spring plate 24 and then passed over the arcuate guide plate 25 and inserted between the rear edge of the lower guide plate 17 and the coil 30 formed on the end of the spring wire 31 which is also secured to the shaft 23 as at 32. Then the bracket 22 with its associated pressing and clamping springs 24 and 30 is moved to its full line position and the web A is loosely clamped in place for engagement by the feeding mechanism.

From this point the web is fed forwardly by means of the feeder arm 35 which is provided with a wedge shaped plate-like head 36 and is rigidly secured upon the transverse operating shaft 38 which has bearings in both of the supporting plates 12 and 13 and is disposed at the center of curvature of the feed slot 15, so that the feeding head 36 is adapted to oscillate in the slot during the feeding and retracting movements thereof. The shaft 38 is provided upon its outer end with a manually operable crank 40 which is provided with a handle 41.

In order to sever the web at the desired point, there is provided at the entering end of the slot 15 a cutting device or shear which is designated generally by the numeral 45 and includes the stationary ledger blade 46 carried by the bracket 47 which is secured to the plate 12 as by means of the rivets 48. The ledger blade 46 is disposed radially of the guide slot 15 and is adapted to cooperate with the pivoted blade 50 which swings about the pivot screw 51 and is urged toward closed position by means of the spring 52 which extends between the rearwardly projecting portion or shank 53 of the blade 50 and the end of the post 54. The spring 52 is adapted to cause the blade 50 to close upon the web with a snap action at the proper point during the forward or feeding stroke of the feeder arm 35, the blade 50 having been retracted and held open during the preliminary backward stroke of the feeder arm 35.

The retraction of the blade is accomplished by the mechanism which is illustrated most clearly in Figure 9 of the drawings and which will now be described. Slidably mounted against the inner face of the side wall or supporting plate 12 is the member 60 which consists mainly of the bar 61 which is adapted to reciprocate, and oscillate to some extent, beneath the retaining strap 63 which is riveted to the plate 12 as at 64. The member 60 is provided with a lower lateral extension 65 and an intermediate laterally extending plate 66 which are joined by means of the connecting element 67. The intermediate extension 66 is provided with an angled portion or flange 68 which is connected with the movable blade 50 of the cutter 45 by means of a link 69, the lower hooked end of which extends through an opening in the flange 68. The member 60 is continually urged upwardly by means of the coil spring 70 which connects the plate 66 with a fixed point 71 on the wall 12. Another spring 72 joining the lower extension 65 with the fixed point 74 on the supporting wall 12 serves to urge the member 60 laterally toward the shaft 38. A notch 75 is

formed in the lower portion of the bar 61 and provides a lower shoulder 76 which is adapted to be engaged by the pin 77 carried by the hub member 78 which is rigidly secured upon the operating shaft 38 as by means of the set screw 79.

It will be readily apparent that upon rotation of the shaft 38 in a counter-clockwise direction, the pin 77 will enter the slot 75, engage the shoulder 76 and retract the member 60, thus drawing the pivoted blade 50 downwardly to permit the entry of the leading edge of the web between the blades of the cutter 45. As the rotation of the pin 77 continues, it will leave the slot 75 and pass off of the shoulder 76 and thus permit the retracting member 60 to snap back into its original position shown in Figure 9. The point at which this release of the member 60 from engagement with the pin 77 occurs may be varied by the adjustment of the screw 80, the inner end 81 of which may contact with the periphery of the shaft 38 at a selected point and cam the bar 61 away from the shaft 38 even before the pin 77 will have passed over the shoulder 76. It will be understood that the release of the retracting member 60 will not cause the blade 50 to operate since at a certain point during the retraction of the blade it will be latched in retracted position by other mechanism which is adapted to be released at a selected point during the movement of the feeding member 35 and which depends upon the length of the portion of the web to be severed from the main body thereof.

During the retracting movement of the blade 50 the reduced squared end 85 thereof will pass radially inwardly through the slot 86 formed in the supporting plate 13 and also through the bayonet slot 87 providing a bifurcation in the upper end of the blade retaining latch member 90 which is freely pivoted at its lower end upon the operating shaft 38 and urged toward a counter-clockwise rotation about the shaft 38 by means of the spring 91 which connects the extended lower end 92 of the latch plate 90 with a fixed point 93 on the lower portion of the plate 13. This counter-clockwise rotation of the latch member 90 is prevented by the contact of the longer arm 95 of the bifurcated upper end of the member 90 with the movable blade 50 of the cutter 45. The slot 87 is provided with a shoulder 96 behind which the end of the blade is retained during the preliminary feeding of the web.

At the proper time the latch member 90 is tripped so that the blade 50 is released from the shoulder 96 and allowed to snap past the ledger blade 46 and sever the web. This tripping mechanism will now be described. Freely carried by the operating shaft 38 is the arm 98 which is provided with an arcuate portion 99 formed with a cam 100 and a tripping shoulder 101 adjacent the forward edge of the cam. The arcuate portion 99 of the lever 98 is provided with a series of perforations 102, one of which is adapted to register with an opening 103 in the feed arm 35 so that the lever 98 and the feed arm 35 may be secured together as by means of the screw 105. This adjustment provides means whereby variable lengths of the web may be severed therefrom. The latch plate 90 is provided with a triangular pawl or dog 107 which is pivoted to the plate 90 by means of the pin 108. The pin 108 is rigid with the dog 107 and extends inwardly beyond the plane of the plate 90 and into the slot 109 formed in the supporting plate 13. The inner projecting end of the pivot pin 108 is provided with a wire spring 110 which passes through an opening in 75.

the pin 111 secured upon the inner face of the plate 13. This spring member 110 is adapted to urge the triangular dog 107 toward its position shown in Fig. 1 of the drawings.

5 During the rearward movement of the feed arm 35 the cam portion 100 of the member 98 will contact with the forward inclined face of the dog 107 and rotate it idly in a clockwise direction and upon clearing the shoulder 101 the dog will again revert to its position shown in Fig. 1 and be in readiness for engagement by the shoulder 101 during the feeding stroke of the member 35. A stationary guide member 115 is secured to the outer face of the plate 13 as at 116, the rearward-ly extending angular end 117 of the guide member 115 being spaced slightly from the plate 13 so as to overlie at least a portion of the latch plate 90 during its various movements. The downwardly facing edge 118 of the member 115 is adapted to engage the upper edge of the pivoted dog 107 and limit its counter-clockwise rotation during the greater portion of the operative cycle of the device. However, during the forward tripping movement of the member 98 which is attached to the feed lever 35 the plate 90 will be moved in a clockwise direction, thus removing the shoulder 96 from above the end 85 of the knife blade 50 and allowing the cutting operation to take place. Further movement in this same direction of the member 98 will cause the dog 107 to rotate upwardly around the downwardly directed portion 118 of the guide member 115 and allow the shoulder 101 to pass by the dog 107.

Rigidly secured upon the shaft 38 adjacent the inner surface of the plate 13 is the ratchet segment 120 with which the pawl 121, pivoted as at 122 upon the plate 13, is adapted to cooperate to prevent a retrograde movement of the operating mechanism during either stroke. The double acting pawl 121 is urged toward a radial position with respect to the shaft 38 by means of the spring 124 which connects the rear end 125 of the pawl 121 with fixed point 126. In Figure 10 of the drawings, the pawl 121 is shown in engagement with the ratchet segment near the beginning of the rearward retractive movement of the feeder. Upon completion of the movement of the shaft 38 in either direction the segment 120 will move beyond the pawl 121 and upon reversal of the movement the pawl will engage the teeth of the latched segment at an opposite inclination.

Upon movement of the feeding member 35 with its feeding head 36 rearwardly beyond the entrance to the slot 15, the rear edge of the plate-like head 36 will move the spring coil 30 upwardly away from the leading end of the web A and will pass over the upper surface of that end of the web causing the web to bend backwardly beneath the forward edge 130 of the arcuate plate 25 as shown in Fig. 4 of the drawings. A pin or post 132 projecting beneath the path of the web from the supporting plate 12 is engaged by the web during this backward bending movement until the leading edge of the web snaps past the post 132 and rests in contact with the upper surface of the feeding head 36. Further retractive movement of the feeding member 35, 36 will permit the leading end of the web A to again snap forwardly into engagement with the rear side of the post 132 as shown in Fig. 5 which holds it in the form of a bight. Then, upon the forward feeding stroke of the feeding member 35, 36, the rear or under surface of the web A will be engaged by the forward relatively sharp edge 135 of the head 36 and the doubled or creased web will then be fed forwardly

by the head 36 between the spring coil 30 and the forward end of the lower guide plate 17, as indicated in Figure 6 of the drawings. If the web is provided with perforations at intervals throughout its length, as in the case of a strip of postage stamps or the like, the forward edge 135 of the feeding member may be provided with minute prongs such as shown at 136 for engagement with certain of the perforations of the web. The forward feeding movement of the forward edge 10 of the web A by means of the feed arm 35 continues until the forward edge is fed outwardly through the delivery opening 138 at the end of the slot 15. During this movement the knife will be tripped at the proper point by the adjustable trip member 98 and the desired length of the web severed from the main portion thereof. The four openings 102 are so spaced along the arcuate arm 99 as to cause the knife or shear to operate at the perforations between the stamps so as to cut out two, three, four or five stamps respectively.

In the embodiment which is illustrated and described herein, the backward retracting movement of the operating shaft 38 by means of the crank 40 beyond a certain point is prevented by means of suitable connections with the check-controlled mechanism designated generally by the reference numeral 150. These connections may include the lever arm 151 which may have a suitable releasable connection with the shaft 38 and which may be connected with appropriate elements of the check-controlled apparatus 150 by means of the pin and slot connection 152. By any suitable or well known means, the rearward movement of the member 151, and thus of the feeding mechanism, may be permitted by the insertion of a check or coin of the proper denomination in the slot 155.

The operation of the device will now be described in the proper sequence illustrated in Figures 1 to 7 inclusive of the drawings. The position in Figure 1 is the initial one in which the various parts of the mechanism are disposed before the insertion of the coin and the operation of the crank 40. The blade 50 of the shear 45 is in engagement with its cooperating ledger blade 46. The forward end of the web A is adjacent these blades and pressed between the spring coil 30 and the rearward end of the guide plate 17, and the feed head 36 is in its extreme forward position. In Figure 2 the parts are shown in their positions as the blade 50 has been partially retracted and as the cam 100 of the tripping member 98 is passing idly by the dog 107. In Figure 3 the feeding head 36 is passing between the blades of the shear 45 and the end 85 of the lower blade 50 has been caught behind the shoulder 96 of the restraining or latch member 90 by the counter-clockwise movement of the member 90 under the influence of the spring 91. The rearward edge of the feeding head 36 is also on the point of displacing the spring coil 30 upwardly from engagement with the upper surface of the leading edge of the web A.

In Figure 4 the feed head 36 is folding the web A rearwardly beneath the arcuate plate 25 and the forward edge of the web A is about to snap past the post 132. By this time the blade retractor member 60 has been released and snaps back into its initial position, the blade being retained behind the shoulder 96 as already described. Figure 5 represents the position of the various parts of the mechanism at the extreme rearward end of the movement thereof. The feed head 36 has cleared the leading edge of the

web A which has snapped forwardly against the post 132 and is partly folded in readiness to be engaged upon its under surface by the forward knife edge 135 of the head 36.

5 In Figure 6 the forward edge 135 of the feed head 36 has doubled the web A rather sharply and, in engagement with the fold therein, is moving the web forwardly beneath the spring 30 and into the entrance of the slot 15. The shoulder
10 101 of the tripping member 98 which moves with the feed arm 35 is in readiness to engage the dog 107 on the retaining member 90. In Figure 7 the shoulder 101 has engaged the dog 107 and moved the retaining plate 90 forwardly sufficiently to
15 allow the blade 50 to clear the shoulder 96 and to snap upwardly through the slot 87 and sever the web at the intended point. Continued forward movement of the feed arm 35 has brought the dog 107 beyond the edge of the portion 118 of
20 the guide member 115 and has allowed it to rotate sufficiently to clear the shoulder 101 and permit the plate 90 to snap rearwardly again to its initial position as shown in Figure 1. It will be obvious that further forward movement of the
25 feed arm 35 will carry the doubled severed portion of the web forwardly along the slot 15 to the delivery point 138, the main portion of the web having its new leading edge disposed just rearwardly of the cutting mechanism 45 and between
30 the spring 30 and the end of the guide surface 17 in readiness for the next cycle of operation.

While the invention has been illustrated and described in connection with a check-controlled
35 stamp vending machine in which the useful portions of the web are separated by rows of perforations, it is obvious that it may be used to feed, cut, and deliver webs or strips of any kind and for any purpose, such as, for example, gummed wrap-
40 ping tapes, ribbons, or the like, whether perforated or not.

Furthermore, the terms "oscillate" and "oscillating", as employed herein in connection with
45 the feeder, are used in their broadest sense, and are intended to include straight line reciprocation as well as swinging movement in an arc of a circle.

It will also be understood that various changes and modifications may be made in the embodi-
50 ment illustrated and described herein without departing from the scope of the invention as defined in the following claims.

What I claim as my invention is:

55 1. In a device of the class described, in combination, a supporting frame, means for retaining and guiding a web supply, an oscillating feeding member for said web adapted to seize said web and move it through its guiding means toward a
60 point of delivery, means for severing from the web a strip of predetermined length, and means adjustably carried by said feeding means for operating said severing means at the desired point during the movement of said feeding means to
65 control the length of the severed strip.

70 2. In a device of the class described, in combination, a supporting frame, an oscillating web feeding member, means for giving said member a preliminary rearward movement and a forward
75 feeding movement, a spring actuated shear for cutting said web, means actuated by said feeding member during its rearward movement for preparing said shear for operation including tensioning said spring, and means carried by said feeding member during its forward feeding move-

ment releasing said shear to cut said web at a predetermined point.

3. In a device of the class described, in combination, a supporting frame, an oscillating web feeding member, means for giving said member
5 a preliminary rearward movement and a forward feeding movement, a cutting blade for severing said web, means for continually urging said blade toward cutting position, means actuated by said
10 feeding member during its rearward movement for retracting said cutter blade, detent means for holding said blade in retracted position, and means actuated by said feeding member during
15 its forward feeding movement for tripping said detent means to release the cutter blade to cut the web at a predetermined point.

4. In a device of the class described, in combination, a supporting frame, an oscillating web feeding member, means for giving said member
20 a preliminary rearward movement and a forward feeding movement, a cutting blade for severing said web, means for continually urging said blade toward cutting position, means connected with
25 said cutter blade for retracting it during the rearward movement of said feeding member, a releasable connection between said feeding member and said retracting means adapted to be engaged during said rearward movement and re-
30 leased before the occurrence of the return or feeding movement of the feeding member, detent means for retaining said blade in retracted position after the release of the retracting means, and means actuated by said feeding member during
35 its forward feeding movement for tripping said detent means to release the cutter blade to cut the web at a predetermined point.

5. In a device of the class described, in combination, a supporting frame, a crank shaft
40 mounted for oscillation in said frame, means for oscillating said shaft, a web feeding arm secured to said shaft, means on said arm for engaging a portion of a web to feed it through
45 said frame, a spring pressed cutter blade for severing from the web a strip of predetermined length, a retractor for said blade, a cam member adapted to be rotated by said shaft and to engage
50 said retractor during part of its rotative movement to cause said blade to be retracted and at one point during said movement to release said retractor, and means on said retractor adapted
55 to be operated upon during the rotation of the shaft to move said retractor away from said cam and effect said release sooner.

6. In a device of the class described, in combination, a supporting frame, a crank shaft
60 mounted for oscillation in said frame, means for oscillating said shaft, a web feeding arm secured to said shaft, means on said arm for engaging a portion of a web to feed it through
65 said frame, a spring pressed cutter blade for severing from the web a strip of predetermined length, a retractor for said blade movable substantially radially of the path of movement of the feeding means, a shoulder on said retractor, a
70 cam member adapted to be rotated by said shaft and to engage the shoulder on said retractor during part of its rotative movement to cause said blade to be retracted and to move past said
75 shoulder at one point during said movement to release said retractor, and adjustable means on said retractor for engaging said shaft, during the rotation of the shaft to move said retractor away from said cam and effect said release sooner.

7. In a device of the class described, in com-

5 bination, a supporting frame, a crank shaft
 mounted for oscillation in said frame, means
 for oscillating said shaft, a web feeding arm
 secured to said shaft, means on said arm for
 10 engaging a portion of a web to feed it through
 said frame, said means adapted to be given a
 preliminary rearward movement in an arcuate
 path when said shaft is rotated in one direction
 and to be given a forward feeding movement
 15 along said path when said shaft is rotated in
 the opposite direction, a spring pressed cutter
 blade for severing from the web a strip of prede-
 termined length, a retractor for said blade mov-
 able substantially radially of the path of move-
 20 ment of the feeding means, a shoulder on said
 retractor, a cam member adapted to be rotated
 by said shaft and to engage the shoulder on said
 retractor during part of its rotative movement to
 cause said blade to be retracted, and to move
 25 past said shoulder at one point during said move-
 ment to release said retractor, adjustable means
 on said retractor for engaging said shaft during
 the rotation of the shaft to move said retractor
 away from said cam and effect said release sooner,
 30 detent means for retaining said blade in re-
 tracted position after release of the retractor,
 and means actuated by said feeding member dur-
 ing its forward feeding stroke to release said
 detent at a predetermined point to effect the
 severing of the web.

8. In a device of the class described, in com-
 bination, a supporting frame, an oscillating feed-
 ing member movable in said frame to feed a web
 therethrough, a spring pressed cutter member
 35 adapted to sever a strip of predetermined length
 from said web, means for retracting said cutter
 member, means for retaining said member in
 retracted position comprising a detent element
 having a portion behind which a part of said
 40 cutter member is adapted to be kept, means res-
 iliently urging said member continually toward
 retaining position, and contact means on said
 retaining means adapted to be engaged by said
 feeder member to trip the detent element and
 45 permit the cutter to operate.

9. In a device of the class described, in com-
 bination, a supporting frame, an oscillating feed-
 ing member movable in said frame to feed a web
 therethrough, means for giving said member a
 50 rearward preliminary movement in one direction
 and a subsequent feeding movement in the oppo-
 site direction, a spring pressed cutter member
 adapted to sever a strip of predetermined length
 from said web, means for retracting said cutter
 55 member, means for retaining said member in
 retracted position comprising a detent element
 having a portion behind which a part of said
 cutter member is adapted to be kept, means res-
 iliently urging said member continually toward
 60 retaining position, a pivoted dog on said retain-
 ing member, a tripper on said feeding member
 adapted to contact said dog and move it idly
 during said preliminary movement, and stop
 65 means to prevent rotation of said dog when con-
 tacted by said tripper on its return movement
 during feeding of the web, whereby said detent
 element is tripped and said cutter member is
 released for operation on the web.

10. In a device of the class described, in com-
 bination, a supporting frame, an oscillating feed-
 ing member movable in said frame to feed a web
 therethrough, means for giving said member a
 rearward preliminary movement in one direction
 70 and a subsequent feeding movement in the oppo-
 site direction, a spring pressed cutter member

adapted to sever a strip of predetermined length
 from said web, means for retracting said cutter
 member, means for retaining said member in
 retracted position comprising a detent element
 having a portion behind which a part of said
 5 cutter member is adapted to be kept, means res-
 iliently urging said member continually toward
 retaining position, a pivoted dog on said retain-
 ing member, a tripper on said feeding member
 adapted to contact said dog and move it idly
 10 during said preliminary movement, and stop
 means carried by said frame and having a con-
 tact surface of limited extent thereon to prevent
 rotation of said dog when contacted by said
 tripper on its return movement during feeding of
 15 the web, whereby said detent element is tripped
 and said cutter member is released for operation
 on the web, and whereby after clearing said con-
 tact surface, said dog is permitted to rotate and
 clear said tripper, and the retaining member re-
 20 turned to its initial position.

11. In a device of the class described, in com-
 bination, a supporting frame, a web roll retain-
 ing bracket pivotally mounted on said frame, a
 stationary guide for the web carried by said
 25 frame, resilient pressing means for cooperating
 with said guide to tension said web between
 them, said means being carried by said bracket
 and alternatively released and applied by pivotal
 movement of said bracket in respective opposite
 30 directions as for inserting and threading up a
 web or clamping the inserted web in readiness
 for operation of the device.

12. In a device of the class described, in com-
 bination, a supporting frame, a web feeding
 35 member mounted for movement in said frame,
 means for forming a bight in the leading end of
 the web, and means for actuating said feeding
 member to engage the bight and draw the web
 through the device.

13. In a device of the class described, in com-
 bination, a supporting frame, a web feeding
 member mounted for movement in said frame,
 means for folding back a short length of the
 leading end of said web and means for actuating
 40 said feeding member to engage within the fold
 of said web and draw the web through the device.

14. In a device of the class described, in com-
 bination, a supporting frame, a web feeding
 member mounted for movement in said frame,
 means for giving said member a preliminary
 45 backward movement and a forward web feeding
 movement, means cooperating with said member
 during its preliminary movement to fold back a
 short length of the leading end of said web, and
 50 dispose the fold in position to be engaged by said
 member during its forward feeding movement.

15. In a device of the class described, in com-
 bination, a supporting frame, a web feeding
 member mounted for movement in said frame,
 means for giving said member a preliminary
 55 backward movement and a forward web feeding
 movement, a guide plate along which said web is
 adapted to move, said guide plate being disposed
 adjacent the rearward portion of the path of
 60 movement of said feeding member and so that
 said member passes along it upon the side thereof
 opposite to that along which said web moves,
 means for supporting the leading end of said web
 in advance of and at the side of the plane of
 65 said plate upon which said feeding member
 moves, whereby during the rearward movement
 of said member it will contact one surface of
 the projecting end of the web and bend it back
 around the forward edge of said plate, move past
 70 said plate, and move past

said bent end and during the return movement engage the bight of the web and draw it forwardly through the device.

16. In a device of the class described, in combination, a supporting frame, an oscillating web feeding member, means for giving said member a preliminary rearward movement and a subsequent forward feeding movement, spaced pairs of upper and lower clamping guides for the leading end of the web disposed adjacent the rearward portion of the path of movement of said feeding member, the foremost pair of said guides being offset from the next adjacent one of said pairs so as to be disposed upon the opposite side of the path of movement of said feeding member, whereby during the rearward movement of said member it will contact one surface of the end portion of said web between said guides and double said portion of the web back behind one of said rearwardly disposed guides and form a fold in said web for engagement by said member during its return feeding movement.

17. In a device of the class described, in combination, a supporting frame, an oscillating web feeding member, means for giving said member a preliminary rearward movement and a subsequent forward feeding movement, spaced pairs of upper and lower clamping guides for the leading end of the web disposed adjacent the rearward portion of the path of movement of said feeding member, the foremost pair of said guides being offset from the next adjacent one of said pairs so as to be disposed upon the opposite side of the path of movement of said feeding member, whereby during the rearward movement of said member it will contact one surface of the end portion of said web between said guides and double said portion of the web back behind one of said rearwardly disposed guides and form a fold in said web for engagement by said member during its return feeding movement, means disposed adjacent said guides for contacting said web and preserving the fold after said member has passed beyond the end thereof during its rearward movement.

18. The method of dispensing sheet strips

from a web supply which comprises holding the new leading end portion of the web while the former end portion is being severed and delivered, folding back a short length of said leading end portion to create a bight therein, seizing said web by said bight and drawing it forwardly to be severed, and delivering the severed portion of the web while the new leading end is seized for effecting the next succeeding cycle of operation.

19. In a device of the class described, in combination, a supporting frame, a web feeding element, means for moving said element to advance the web through the device, a snap acting cutter member for severing from the moving web a portion of predetermined length, an actuating member for said cutter member, means for adjustably securing said actuating member directly to said feeding element, whereby said cutter may be actuated at a selected point during the movement of said feeding element to sever variable lengths of material from said web.

20. In a device of the class described, in combination, a web feeding element, means to move said element, a shear having a fixed and a movable blade, means to cock said movable blade with at least one end remote from the fixed blade, means to release said cocked blade on continued feeding movement of said feeding element, to cut said web and means to adjustably secure said blade releasing means onto said web feeding element to determine the cutting in respect to the amount of web fed past the fixed blade.

21. In a device of the class described, in combination, a web feeding element adapted to seize a web and move its end through a predetermined distance to a point of delivery, a shear having a fixed and a movable blade, means to separate said blades during retrograde movement of said feeding element, means to actuate the movable blade to sever the web end during feeding thereof and before delivery, said actuating means being carried by said feeding element, and means to adjustably position said actuating means on said element to determine the length of web severed.

WILLIAM V. DERBY.