



- (51) International Patent Classification:
G06Q 50/30 (2012.01) *H04W 40/02* (2009.01)
- (21) International Application Number:
PCT/US2014/069702
- (22) International Filing Date:
11 December 2014 (11.12.2014)
- (25) Filing Language: English
- (26) Publication Language: English
- (30) Priority Data:
14/565,371 9 December 2014 (09.12.2014) US
- (71) Applicant: **FACEBOOK, INC.** [US/US]; 1601 Willow Road, Menlo Park, CA 94025 (US).
- (72) Inventors: **LEBEAU, Michael, James**; 1601 Willow Road, Menlo Park, CA 94025 (US). **LESSIN, Samuel, Wharton**; 1601 Willow Road, Menlo Park, CA 94025 (US). **BARILLARI, Joseph, David**; 1601 Willow Road, Menlo Park, CA 94025 (US). **SHIMONI, Amir**; 1601 Willow Road, Menlo Park, CA 94025 (US). **MURILLO, Arlene, Gabriela**; 1601 Willow Road, Menlo Park, CA 94025 (US). **NIEWCZAS, Mateusz, Marek**; 1601 Wil-

low Road, Menlo Park, CA 94025 (US). **MODI, Manish**; 1601 Willow Road, Menlo Park, CA 94025 (US). **KALINOWSKI, Caitlin, E.**; 1601 Willow Road, Menlo Park, CA 94025 (US).

(74) Agent: **EATON, L., May**; Baker Botts L.L.P., 2001 Ross Avenue, Suite 600, Dallas, TX 75201 (US).

(81) Designated States (unless otherwise indicated, for every kind of national protection available): AE, AG, AL, AM, AO, AT, AU, AZ, BA, BB, BG, BH, BN, BR, BW, BY, BZ, CA, CH, CL, CN, CO, CR, CU, CZ, DE, DK, DM, DO, DZ, EC, EE, EG, ES, FI, GB, GD, GE, GH, GM, GT, HN, HR, HU, ID, IL, IN, IR, IS, JP, KE, KG, KN, KP, KR, KZ, LA, LC, LK, LR, LS, LU, LY, MA, MD, ME, MG, MK, MN, MW, MX, MY, MZ, NA, NG, NI, NO, NZ, OM, PA, PE, PG, PH, PL, PT, QA, RO, RS, RU, RW, SA, SC, SD, SE, SG, SK, SL, SM, ST, SV, SY, TH, TJ, TM, TN, TR, TT, TZ, UA, UG, US, UZ, VC, VN, ZA, ZM, ZW.

(84) Designated States (unless otherwise indicated, for every kind of regional protection available): ARIPO (BW, GH, GM, KE, LR, LS, MW, MZ, NA, RW, SD, SL, ST, SZ, TZ, UG, ZM, ZW), Eurasian (AM, AZ, BY, KG, KZ, RU, TJ, TM), European (AL, AT, BE, BG, CH, CY, CZ, DE,

[Continued on next page]

(54) Title: GENERATING USER NOTIFICATIONS USING BEACONS ON ONLINE SOCIAL NETWORKS

(57) Abstract: In one embodiment, a method includes receiving, from a beacon associated with a third-party content provider (e.g., a business), session information of the first user of an online social network. The first user's mobile device may be proximate to and in a wireless communication session with the beacon, which may be located at the third-party content provider. One or more second users, who are each connected to the first user in a social graph, may be selected. A communication session is not active between the beacon and the mobile devices of the second users. The selection may be based on selected second users being located within a predefined distance of the beacon (e.g., in the same neighborhood). A notification referencing selected second users (e.g., a prompt to invite the selected second users to the beacon location) may be sent to the first user's mobile device.

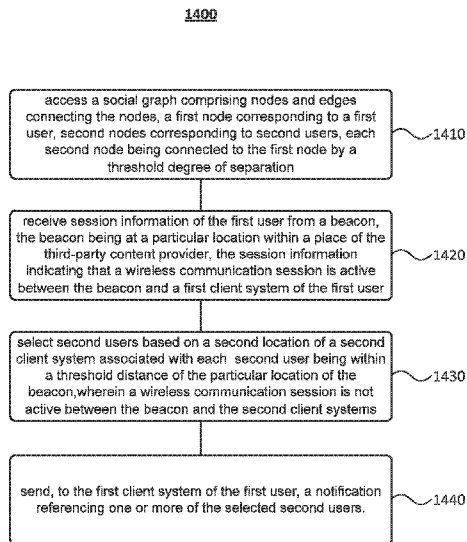

FIG. 14

WO 2016/093831 A1

DK, EE, ES, FI, FR, GB, GR, HR, HU, IE, IS, IT, LT, **Published:**
LU, LV, MC, MK, MT, NL, NO, PL, PT, RO, RS, SE, — *with international search report (Art. 21(3))*
SI, SK, SM, TR), OAPI (BF, BJ, CF, CG, CI, CM, GA,
GN, GQ, GW, KM, ML, MR, NE, SN, TD, TG).

GENERATING USER NOTIFICATIONS USING BEACONS ON ONLINE SOCIAL NETWORKS

TECHNICAL FIELD

[0001] This disclosure generally relates to exchanging information over wireless communications sessions, particularly within the context of an online social network.

BACKGROUND

[0002] A social-networking system, which may include a social-networking website, may enable its users (such as persons or organizations) to interact with it and with each other through it. The social-networking system may, with input from a user, create and store in the social-networking system a user profile associated with the user. The user profile may include demographic information, communication-channel information, and information on personal interests of the user. The social-networking system may also, with input from a user, create and store a record of relationships of the user with other users of the social-networking system, as well as provide services (*e.g.*, wall posts, photo-sharing, event organization, messaging, games, or advertisements) to facilitate social interaction between or among users.

[0003] The social-networking system may send over one or more networks content or messages related to its services to a mobile or other computing device of a user. A user may also install software applications on a mobile or other computing device of the user for accessing a user profile of the user and other data within the social-networking system. The social-networking system may generate a personalized set of content objects to display to a user, such as a newsfeed of aggregated stories of other users connected to the user.

[0004] Social-graph analysis views social relationships in terms of network theory consisting of nodes and edges. Nodes represent the individual actors within the networks, and edges represent the relationships between the actors. The resulting graph-based structures are often very complex. There can be many types of nodes and many types of edges for connecting nodes. In its simplest form, a social graph is a map of all of the relevant edges between all the nodes being studied.

SUMMARY OF PARTICULAR EMBODIMENTS

[0005] In particular embodiments, a social-networking system may facilitate the establishment and confirmation of a wireless communication session between a beacon and a user's client system proximate to the beacon in order to enhance a user's experience at the beacon-holder business. After a wireless communication session is established, the social-networking system may send social-networking information of the user to a third-party content provider associated with the beacon (*i.e.*, the beacon holder), by way of the beacon. The social-networking information sent to the third-party content provider may be customized based on the type of goods purveyed or services rendered by the third-party content provider. For example, if the third-party content provider is a department store, the social-networking system may send social-networking information of the user that includes color preferences and shoe and clothing sizes of the user. In another example, if the third-party content provider is a restaurant, the social-networking system may send social-networking information of the user that includes food allergies and favorite foods. The social-networking information of the user may, in turn, be used by the third-party content provider to personalize third-party content, which may be sent to the user's client system by the third-party content provider, either directly or via the beacon. The third-party content provider may also send third-party content to the social-networking system, which may personalize the third-party content and send it to the user's client system. For example and not by way of limitation, a third-party content provider may be a book retailer and may receive social-networking information that includes a list of books recently read by the user, and the third-party content provider may send the user titles of suggested books to read, which may be available for purchase at the third-party content provider.

[0006] In particular embodiments, a social-networking system may anonymize and aggregate social-networking information and session information of multiple users whose client systems have been associated with beacons of a third-party content provider in wireless communication sessions. Session information may include, for example and not by way of limitation, a history of past wireless communication sessions established between a client system and one or more beacons of a third-party content provider. The social-networking system may generate a report including any number of statistics (*i.e.*, business insights) generated based on

the aggregated clientele information. For example, the report may include an average customer age and a number of customers who are first time visitors to the third-party content provider. In particular embodiments, the report may include individual profiles (*e.g.*, showing a picture and name) for the users whose client systems are presently in a wireless communication session with the beacon (*i.e.*, the users who are currently at the third-party content provider location).

[0007] In particular embodiments, a social-networking system may customize and send an advertisement to a particular user based on the social-networking information and session information of the user. For example, a user's session information may indicate that a user was a frequent patron of a particular restaurant but has not been there in a few months and may send the user's client system an advertisement (*e.g.*, a coupon) in order to attract the user's patronage once again. A social-networking system, or third-party content provider via the social-networking system, may target users for a particular advertisement based on interactions with beacons by a user's social connections. For example, if a number of a user's social connections have checked-in at a particular pub, the social-networking system may send the user an advertisement for the pub.

[0008] In particular embodiments, a social-networking system may customize and provide a notification to a user of an online social network based on social-networking information (*e.g.*, location information) and session information of the user. For example, a user's location information may indicate that the user is nearby a particular restaurant, and the social-networking system may send a notification to the user's client system indicating that he is near the restaurant and providing information about the restaurant (*e.g.*, menu and reviews). The social-networking system may also customize notifications based on social-networking and session information of the user's social connections. For example, the notification may specify friends of the user who are already at the restaurant (*e.g.*, based on session information for the friends received from a beacon located at the restaurant). Notifications may also provide arrival and departure information pertaining to the user's social connections (*e.g.*, a notification indicating that John left the restaurant fifteen minutes ago). In particular embodiments, the social-networking system may use session information of a user to determine that he is located at a particular bar and provide a notification to the user prompting him to invite other users to join him and providing a list of suggested invitees. For example, the social-networking system may

determine that social connections of the user who are nearby the bar should be suggested invitees. The social-networking system may further refine who it pushes as a suggested invitee based on social-networking information of the other users (*e.g.*, based on preferences or affinities of the other users).

[0009] The embodiments disclosed above are only examples, and the scope of this disclosure is not limited to them. Particular embodiments may include all, some, or none of the components, elements, features, functions, operations, or steps of the embodiments disclosed above. Embodiments according to the invention are in particular disclosed in the attached claims directed to a method, a storage medium, a system and a computer program product, wherein any feature mentioned in one claim category, *e.g.*, method, can be claimed in another claim category, *e.g.*, system, as well. The dependencies or references back in the attached claims are chosen for formal reasons only. However any subject matter resulting from a deliberate reference back to any previous claims (in particular multiple dependencies) can be claimed as well, so that any combination of claims and the features thereof are disclosed and can be claimed regardless of the dependencies chosen in the attached claims. The subject-matter which can be claimed comprises not only the combinations of features as set out in the attached claims but also any other combination of features in the claims, wherein each feature mentioned in the claims can be combined with any other feature or combination of other features in the claims. Furthermore, any of the embodiments and features described or depicted herein can be claimed in a separate claim and/or in any combination with any embodiment or feature described or depicted herein or with any of the features of the attached claims.

[0010] In an embodiment according to the invention, a method comprises, by one or more computing devices of an online social network:

accessing a social graph comprising a plurality of nodes and a plurality of edges connecting the nodes, each of the edges between two of the nodes representing a single degree of separation between them, the nodes comprising:

a first node corresponding to a first user of the online social network, and

a plurality of second nodes respectively corresponding to a plurality of second users associated with the online social network, each second node being connected to the first node in the social graph by a threshold degree of separation;

receiving, from a beacon associated with a third-party content provider, session information of the first user, wherein:

the beacon is associated with a particular location within a place associated with the third-party content provider, and

the session information of the first user indicates that a first client system of the first user is within wireless range of and proximate to the beacon, a wireless communication session being active between the beacon and the first client system;

selecting one or more of the second users, wherein the selecting is based on a second location of a second client system associated with the second user, the second location being within a threshold distance of the particular location of the beacon, and wherein a wireless communication session is not active between the beacon and each of second client systems associated with the selected second users; and

sending, to the first client system of the first user, a notification referencing one or more of the selected second users.

[0011] The threshold degree of separation may be one, two, three, or all.

[0012] In an embodiment according to the invention, the method further may comprise:

receiving, from the first client system, a request to invite at least one of the selected second users referenced in the notification to the place associated with the third-party content provider; and

sending, in response to the request, a message to the second client system of the at least one selected second user.

[0013] In an embodiment according to the invention, the method further may comprise:

sending, to the first client system, updated location information for the at least one selected second user when a wireless communication system is established between the second client system of the at least one second user and the beacon.

[0014] The message may comprise:

an invitation to join the first user at the place associated with the third-party content provider; and

a prompt to respond to the invitation.

[0015] The message further may comprise location information of the place associated with the third-party content provider.

[0016] The message further may comprise an identifier of at least one third user of an online social network, the at least one third user being associated with a respective third client system, wherein a wireless communication session is active between the beacon and the third client system.

[0017] In an embodiment according to the invention, the method further may comprise receiving, from the beacon, session information for at least one second user.

[0018] The selecting of one or more second users may be further based on the received session information of the at least one second user.

[0019] The session information of the at least one second user may comprise a history of one or more prior wireless communication sessions established between the beacon and the second client system of the at least one second user.

[0020] The selecting of one or more second users may be further based on user preferences of at least one second user.

[0021] The user preferences of the at least one second user may indicate a preference for a type of good or service, and wherein the third-party content provider comprises the preferred type of good or service.

[0022] The selecting of one or more second users may be further based on an affinity coefficient of at least one second node with respect to a third node in the social graph, the third node corresponding to the third-party content provider.

[0023] The affinity coefficient may be based on one or more edges connecting the at least one second node to the third node.

[0024] In an embodiment according to the invention, which can be claimed as well, one or more computer-readable non-transitory storage media embody software that is operable when executed to:

access a social graph comprising a plurality of nodes and a plurality of edges connecting the nodes, each of the edges between two of the nodes representing a single degree of separation between them, the nodes comprising:

a first node corresponding to a first user of the online social network, and

a plurality of second nodes respectively corresponding to a plurality of second users associated with the online social network, each second node being connected to the first node in the social graph by a threshold degree of separation;

receive, from a beacon associated with a third-party content provider, session information of the first user, wherein:

the beacon is associated with a particular location within a place associated with the third-party content provider, and

the session information of the first user indicates that a first client system of the first user is within wireless range of and proximate to the beacon, a wireless communication session being active between the beacon and the first client system;

select one or more of the second users, wherein the selecting is based on a second location of a second client system associated with the second user, the second location being within a threshold distance of the particular location of the beacon, and wherein a wireless communication session is not active between the beacon and each of second client systems associated with the selected second users; and

send, to the first client system of the first user, a notification referencing one or more of the selected second users.

[0025] In an embodiment according to the invention, which can be claimed as well, the media may further comprise:

receiving, from the first client system, a request to invite at least one of the selected second users referenced in the notification to the place associated with the third-party content provider; and

sending, in response to the request, a message to the second client system of the at least one selected second user.

[0026] In an embodiment according to the invention, which can be claimed as well, the media may further comprise:

sending, to the first client system, updated location information for the at least one selected second user when a wireless communication system is established between the second client system of the at least one second user and the beacon.

[0027] In an embodiment according to the invention, which can be claimed as well, a system comprises: one or more processors; and a memory coupled to the processors comprising instructions executable by the processors, the processors being operable when executing the instructions to:

access a social graph comprising a plurality of nodes and a plurality of edges connecting the nodes, each of the edges between two of the nodes representing a single degree of separation between them, the nodes comprising:

a first node corresponding to a first user of the online social network, and

a plurality of second nodes respectively corresponding to a plurality of second users associated with the online social network, each second node being connected to the first node in the social graph by a threshold degree of separation;

receive, from a beacon associated with a third-party content provider, session information of the first user, wherein:

the beacon is associated with a particular location within a place associated with the third-party content provider, and

the session information of the first user indicates that a first client system of the first user is within wireless range of and proximate to the beacon, a wireless communication session being active between the beacon and the first client system;

select one or more of the second users, wherein the selecting is based on a second location of a second client system associated with the second user, the second location being within a threshold distance of the particular location of the beacon, and wherein a wireless communication session is not active between the beacon and each of second client systems associated with the selected second users; and

send, to the first client system of the first user, a notification referencing one or more of the selected second users.

[0028] In an embodiment according to the invention, which can be claimed as well, the system may further comprise:

receiving, from the first client system, a request to invite at least one of the selected second users referenced in the notification to the place associated with the third-party content provider; and

sending, in response to the request, a message to the second client system of the at least one selected second user.

[0029] The message may comprise:

an invitation to join the first user at the place associated with the third-party content provider; and

a prompt to respond to the invitation.

[0030] In an embodiment according to the invention, which can be claimed as well, the system may further comprise:

sending, to the first client system, updated location information for the at least one selected second user when a wireless communication system is established between the second client system of the at least one second user and the beacon.

[0031] In a further embodiment according to the invention, one or more computer-readable non-transitory storage media embody software that is operable when executed to perform a method according to the invention or any of the above mentioned embodiments.

[0032] In a further embodiment according to the invention, a system comprises: one or more processors; and at least one memory coupled to the processors and comprising instructions executable by the processors, the processors operable when executing the instructions to perform a method according to the invention or any of the above mentioned embodiments.

[0033] In a further embodiment according to the invention, a computer program product, preferably comprising a computer-readable non-transitory storage media, is operable when executed on a data processing system to perform a method according to the invention or any of the above mentioned embodiments.

BRIEF DESCRIPTION OF THE DRAWINGS

[0034] FIG. 1 illustrates an example network environment associated with a social-networking system.

[0035] FIG. 2 illustrates an example social graph.

[0036] FIG. 3 illustrates an example beacon environment associated with a social-networking system.

[0037] FIG. 4A illustrates an example report view of an interface displayed on a third-party system.

[0038] FIG. 4B illustrates an example profile view of an interface displayed on a third-party system.

[0039] FIG. 4C illustrates an example detailed profile view of an interface displayed on a third-party system.

[0040] FIG. 5 illustrates example ads of a third-party content provider displayed in interface of a client system.

[0041] FIG. 6 illustrates an example method for sending customized third-party content to a client system.

[0042] FIG. 7 illustrates an example method for sending a report to a third-party system.

[0043] FIG. 8 illustrates an example method for sending a customized advertisement to a client system.

[0044] FIG. 9A illustrates an example notification displayed on a lock screen of a client system.

[0045] FIG. 9B illustrates an example notification displayed in an interface of a client system.

[0046] FIG. 9C illustrates an example notification displayed in an interface of a client system.

[0047] FIG. 9D illustrates an example page corresponding to a third-party content provider displayed in an interface of a client system.

[0048] FIG. 9E illustrates an example page corresponding to a third-party content provider displayed in an interface of a client system.

[0049] FIG. 10A illustrates an example notification displayed on a lock screen of a client system.

[0050] FIG. 10B illustrates an example notification displayed in an interface of a client system.

[0051] FIG. 10C illustrates an example page corresponding to a third-party content provider displayed in an interface of a client system.

[0052] FIG. 11A illustrates an example notification displayed on a lock screen of a client system.

[0053] FIG. 11B illustrates an example notification displayed in an interface of a client system.

[0054] FIG. 11C illustrates an example notification and a page corresponding to a third-party content provider displayed in an interface of a client system.

[0055] FIG. 11D illustrates an example notification and a page corresponding to a third-party content provider displayed in an interface of a client system.

[0056] FIG. 12 illustrates an example self-portrait interface displayed on a client system.

[0057] FIG. 13 illustrates an example beacon in a real-world environment.

[0058] FIG. 14 illustrates an example method for sending a notification to a client system.

[0059] FIG. 15 illustrates an example computer system.

DESCRIPTION OF EXAMPLE EMBODIMENTS

System Overview

[0060] FIG. 1 illustrates an example network environment 100 associated with a social-networking system. Network environment 100 includes a client system 130, a social-networking system 160, and a third-party system 170 connected to each other by a network 110. Although FIG. 1 illustrates a particular arrangement of client system 130, social-networking system 160, third-party system 170, and network 110, this disclosure contemplates any suitable arrangement of client system 130, social-networking system 160, third-party system 170, and network 110. As an example and not by way of limitation, two or more of client system 130, social-networking system 160, and third-party system 170 may be connected to each other directly, bypassing network 110. As another example, two or more of client system 130, social-networking system 160, and third-party system 170 may be physically or logically co-located with each other in whole or in part. Moreover, although FIG. 1 illustrates a particular number of client systems 130, social-networking systems 160, third-party systems 170, and networks 110, this disclosure contemplates any suitable number of client systems 130, social-networking systems 160, third-party systems 170, and networks 110. As an example and not by way of limitation, network

environment **100** may include multiple client system **130**, social-networking systems **160**, third-party systems **170**, and networks **110**.

[0061] This disclosure contemplates any suitable network **110**. As an example and not by way of limitation, one or more portions of network **110** may include an ad hoc network, an intranet, an extranet, a virtual private network (VPN), a local area network (LAN), a wireless LAN (WLAN), a wide area network (WAN), a wireless WAN (WWAN), a metropolitan area network (MAN), a portion of the Internet, a portion of the Public Switched Telephone Network (PSTN), a cellular telephone network, or a combination of two or more of these. Network **110** may include one or more networks **110**.

[0062] Links **150** may connect client system **130**, social-networking system **160**, and third-party system **170** to communication network **110** or to each other. This disclosure contemplates any suitable links **150**. In particular embodiments, one or more links **150** include one or more wireline (such as for example Digital Subscriber Line (DSL) or Data Over Cable Service Interface Specification (DOCSIS)), wireless (such as for example Wi-Fi or Worldwide Interoperability for Microwave Access (WiMAX)), or optical (such as for example Synchronous Optical Network (SONET) or Synchronous Digital Hierarchy (SDH)) links. In particular embodiments, one or more links **150** each include an ad hoc network, an intranet, an extranet, a VPN, a LAN, a WLAN, a WAN, a WWAN, a MAN, a portion of the Internet, a portion of the PSTN, a cellular technology-based network, a satellite communications technology-based network, another link **150**, or a combination of two or more such links **150**. Links **150** need not necessarily be the same throughout network environment **100**. One or more first links **150** may differ in one or more respects from one or more second links **150**.

[0063] In particular embodiments, client system **130** may be an electronic device including hardware, software, or embedded logic components or a combination of two or more such components and capable of carrying out the appropriate functionalities implemented or supported by client system **130**. As an example and not by way of limitation, a client system **130** may include a computer system such as a desktop computer, notebook or laptop computer, netbook, a tablet computer, e-book reader, GPS device, camera, personal digital assistant (PDA), handheld electronic device, cellular telephone, smartphone, other suitable electronic device, or any suitable combination thereof. This disclosure contemplates any suitable client systems **130**.

A client system **130** may enable a network user at client system **130** to access network **110**. A client system **130** may enable its user to communicate with other users at other client systems **130**.

[0064] In particular embodiments, client system **130** may include a web browser **132**, such as MICROSOFT INTERNET EXPLORER, GOOGLE CHROME or MOZILLA FIREFOX, and may have one or more add-ons, plug-ins, or other extensions, such as TOOLBAR or YAHOO TOOLBAR. A user at client system **130** may enter a Uniform Resource Locator (URL) or other address directing the web browser **132** to a particular server (such as server **162**, or a server associated with a third-party system **170**), and the web browser **132** may generate a Hyper Text Transfer Protocol (HTTP) request and communicate the HTTP request to server. The server may accept the HTTP request and communicate to client system **130** one or more Hyper Text Markup Language (HTML) files responsive to the HTTP request. Client system **130** may render a webpage based on the HTML files from the server for presentation to the user. This disclosure contemplates any suitable webpage files. As an example and not by way of limitation, webpages may render from HTML files, Extensible Hyper Text Markup Language (XHTML) files, or Extensible Markup Language (XML) files, according to particular needs. Such pages may also execute scripts such as, for example and without limitation, those written in JAVASCRIPT, JAVA, MICROSOFT SILVERLIGHT, combinations of markup language and scripts such as AJAX (Asynchronous JAVASCRIPT and XML), and the like. Herein, reference to a webpage encompasses one or more corresponding webpage files (which a browser may use to render the webpage) and vice versa, where appropriate.

[0065] In particular embodiments, social-networking system **160** may be a network-addressable computing system that can host an online social network. Social-networking system **160** may generate, store, receive, and send social-networking data, such as, for example, user-profile data, concept-profile data, social-graph information, or other suitable data related to the online social network. Social-networking system **160** may be accessed by the other components of network environment **100** either directly or via network **110**. In particular embodiments, social-networking system **160** may include one or more servers **162**. Each server **162** may be a unitary server or a distributed server spanning multiple computers or multiple datacenters. Servers **162** may be of various types, such as, for example and without limitation, web server,

news server, mail server, message server, advertising server, file server, application server, exchange server, database server, proxy server, another server suitable for performing functions or processes described herein, or any combination thereof. In particular embodiments, each server **162** may include hardware, software, or embedded logic components or a combination of two or more such components for carrying out the appropriate functionalities implemented or supported by server **162**. In particular embodiments, social-networking system **160** may include one or more data stores **164**. Data stores **164** may be used to store various types of information. In particular embodiments, the information stored in data stores **164** may be organized according to specific data structures. In particular embodiments, each data store **164** may be a relational, columnar, correlation, or other suitable database. Although this disclosure describes or illustrates particular types of databases, this disclosure contemplates any suitable types of databases. Particular embodiments may provide interfaces that enable a client system **130**, a social-networking system **160**, or a third-party system **170** to manage, retrieve, modify, add, or delete, the information stored in data store **164**.

[0066] In particular embodiments, social-networking system **160** may store one or more social graphs in one or more data stores **164**. In particular embodiments, a social graph may include multiple nodes—which may include multiple user nodes (each corresponding to a particular user) or multiple concept nodes (each corresponding to a particular concept)—and multiple edges connecting the nodes. Social-networking system **160** may provide users of the online social network the ability to communicate and interact with other users. In particular embodiments, users may join the online social network via social-networking system **160** and then add connections (*e.g.*, relationships) to a number of other users of social-networking system **160** to whom they want to be connected. Herein, the term “friend” may refer to any other user of social-networking system **160** with whom a user has formed a connection, association, or relationship via social-networking system **160**.

[0067] In particular embodiments, social-networking system **160** may provide users with the ability to take actions on various types of items or objects, supported by social-networking system **160**. As an example and not by way of limitation, the items and objects may include groups or social networks to which users of social-networking system **160** may belong, events or calendar entries in which a user might be interested, computer-based applications that a user may

use, transactions that allow users to buy or sell items via the service, interactions with advertisements that a user may perform, or other suitable items or objects. A user may interact with anything that is capable of being represented in social-networking system **160** or by an external system of third-party system **170**, which is separate from social-networking system **160** and coupled to social-networking system **160** via a network **110**.

[0068] In particular embodiments, social-networking system **160** may be capable of linking a variety of entities. As an example and not by way of limitation, social-networking system **160** may enable users to interact with each other as well as receive content from third-party systems **170** or other entities, or to allow users to interact with these entities through an application programming interfaces (API) or other communication channels.

[0069] In particular embodiments, a third-party system **170** may include one or more types of servers, one or more data stores, one or more interfaces, including but not limited to APIs, one or more web services, one or more content sources, one or more networks, or any other suitable components, *e.g.*, with which servers may communicate. A third-party system **170** may be operated by a different entity from an entity operating social-networking system **160**. In particular embodiments, however, social-networking system **160** and third-party systems **170** may operate in conjunction with each other to provide social-networking services to users of social-networking system **160** or third-party systems **170**. In this sense, social-networking system **160** may provide a platform, or backbone, which other systems, such as third-party systems **170**, may use to provide social-networking services and functionality to users across the Internet.

[0070] In particular embodiments, a third-party system **170** may include a third-party content object provider. A third-party content object provider may include one or more sources of content objects, which may be communicated to a client system **130**. As an example and not by way of limitation, content objects may include information regarding things or activities of interest to the user, such as, for example, movie show times, movie reviews, restaurant reviews, restaurant menus, product information and reviews, or other suitable information. As another example and not by way of limitation, content objects may include incentive content objects, such as coupons, discount tickets, gift certificates, or other suitable incentive objects.

[0071] In particular embodiments, social-networking system **160** also includes user-generated content objects, which may enhance a user's interactions with social-networking

system **160**. User-generated content may include anything a user can add, upload, send, or “post” to social-networking system **160**. As an example and not by way of limitation, a user communicates posts to social-networking system **160** from a client system **130**. Posts may include data such as status updates or other textual data, location information, photos, videos, links, music or other similar data or media. Content may also be added to social-networking system **160** by a third-party through a “communication channel,” such as a newsfeed or stream.

[0072] In particular embodiments, social-networking system **160** may include a variety of servers, sub-systems, programs, modules, logs, and data stores. In particular embodiments, social-networking system **160** may include one or more of the following: a web server, action logger, API-request server, relevance-and-ranking engine, content-object classifier, notification controller, action log, third-party-content-object-exposure log, inference module, authorization/privacy server, search module, advertisement-targeting module, user-interface module, user-profile store, connection store, third-party content store, or location store. Social-networking system **160** may also include suitable components such as network interfaces, security mechanisms, load balancers, failover servers, management-and-network-operations consoles, other suitable components, or any suitable combination thereof. In particular embodiments, social-networking system **160** may include one or more user-profile stores for storing user profiles. A user profile may include, for example, biographic information, demographic information, behavioral information, social information, or other types of descriptive information, such as work experience, educational history, hobbies or preferences, interests, affinities, or location. Interest information may include interests related to one or more categories. Categories may be general or specific. As an example and not by way of limitation, if a user “likes” an article about a brand of shoes the category may be the brand, or the general category of “shoes” or “clothing.” A connection store may be used for storing connection information about users. The connection information may indicate users who have similar or common work experience, group memberships, hobbies, educational history, or are in any way related or share common attributes. The connection information may also include user-defined connections between different users and content (both internal and external). A web server may be used for linking social-networking system **160** to one or more client systems **130** or one or more third-party system **170** via network **110**. The web server may include a mail server or other

messaging functionality for receiving and routing messages between social-networking system **160** and one or more client systems **130**. An API-request server may allow a third-party system **170** to access information from social-networking system **160** by calling one or more APIs. An action logger may be used to receive communications from a web server about a user's actions on or off social-networking system **160**. In conjunction with the action log, a third-party-content-object log may be maintained of user exposures to third-party-content objects. A notification controller may provide information regarding content objects to a client system **130**. Information may be pushed to a client system **130** as notifications, or information may be pulled from client system **130** responsive to a request received from client system **130**. Authorization servers may be used to enforce one or more privacy settings of the users of social-networking system **160**. A privacy setting of a user determines how particular information associated with a user can be shared. The authorization server may allow users to opt in to or opt out of having their actions logged by social-networking system **160** or shared with other systems (*e.g.*, third-party system **170**), such as, for example, by setting appropriate privacy settings. Third-party-content-object stores may be used to store content objects received from third parties, such as a third-party system **170**. Location stores may be used for storing location information received from client systems **130** associated with users. Advertisement-pricing modules may combine social information, the current time, location information, or other suitable information to provide relevant advertisements, in the form of notifications, to a user.

Social Graphs

[0073] FIG. 2 illustrates example social graph **200**. In particular embodiments, social-networking system **160** may store one or more social graphs **200** in one or more data stores. In particular embodiments, social graph **200** may include multiple nodes—which may include multiple user nodes **202** or multiple concept nodes **204**—and multiple edges **206** connecting the nodes. Example social graph **200** illustrated in FIG. 2 is shown, for didactic purposes, in a two-dimensional visual map representation. In particular embodiments, a social-networking system **160**, client system **130**, or third-party system **170** may access social graph **200** and related social-graph information for suitable applications. The nodes and edges of social graph **200** may be stored as data objects, for example, in a data store (such as a social-graph database). Such a data

store may include one or more searchable or queryable indexes of nodes or edges of social graph **200**.

[0074] In particular embodiments, a user node **202** may correspond to a user of social-networking system **160**. As an example and not by way of limitation, a user may be an individual (human user), an entity (*e.g.*, an enterprise, business, or third-party application), or a group (*e.g.*, of individuals or entities) that interacts or communicates with or over social-networking system **160**. In particular embodiments, when a user registers for an account with social-networking system **160**, social-networking system **160** may create a user node **202** corresponding to the user, and store the user node **202** in one or more data stores. Users and user nodes **202** described herein may, where appropriate, refer to registered users and user nodes **202** associated with registered users. In addition or as an alternative, users and user nodes **202** described herein may, where appropriate, refer to users that have not registered with social-networking system **160**. In particular embodiments, a user node **202** may be associated with information provided by a user or information gathered by various systems, including social-networking system **160**. As an example and not by way of limitation, a user may provide his or her name, profile picture, contact information, birth date, sex, marital status, family status, employment, education background, preferences, interests, or other demographic information. In particular embodiments, a user node **202** may be associated with one or more data objects corresponding to information associated with a user. In particular embodiments, a user node **202** may correspond to one or more webpages.

[0075] In particular embodiments, a concept node **204** may correspond to a concept. As an example and not by way of limitation, a concept may correspond to a place (such as, for example, a movie theater, restaurant, landmark, or city); a website (such as, for example, a website associated with social-network system **160** or a third-party website associated with a web-application server); an entity (such as, for example, a person, business, group, sports team, or celebrity); a resource (such as, for example, an audio file, video file, digital photo, text file, structured document, or application) which may be located within social-networking system **160** or on an external server, such as a web-application server; real or intellectual property (such as, for example, a sculpture, painting, movie, game, song, idea, photograph, or written work); a game; an activity; an idea or theory; another suitable concept; or two or more such concepts. A

concept node **204** may be associated with information of a concept provided by a user or information gathered by various systems, including social-networking system **160**. As an example and not by way of limitation, information of a concept may include a name or a title; one or more images (*e.g.*, an image of the cover page of a book); a location (*e.g.*, an address or a geographical location); a website (which may be associated with a URL); contact information (*e.g.*, a phone number or an email address); other suitable concept information; or any suitable combination of such information. In particular embodiments, a concept node **204** may be associated with one or more data objects corresponding to information associated with concept node **204**. In particular embodiments, a concept node **204** may correspond to one or more webpages.

[0076] In particular embodiments, a node in social graph **200** may represent or be represented by a webpage (which may be referred to as a “profile page”). Profile pages may be hosted by or accessible to social-networking system **160**. Profile pages may also be hosted on third-party websites associated with a third-party server **170**. As an example and not by way of limitation, a profile page corresponding to a particular external webpage may be the particular external webpage and the profile page may correspond to a particular concept node **204**. Profile pages may be viewable by all or a selected subset of other users. As an example and not by way of limitation, a user node **202** may have a corresponding user-profile page in which the corresponding user may add content, make declarations, or otherwise express himself or herself. As another example and not by way of limitation, a concept node **204** may have a corresponding concept-profile page in which one or more users may add content, make declarations, or express themselves, particularly in relation to the concept corresponding to concept node **204**.

[0077] In particular embodiments, a concept node **204** may represent a third-party webpage or resource hosted by a third-party system **170**. The third-party webpage or resource may include, among other elements, content, a selectable or other icon, or other inter-actable object (which may be implemented, for example, in JavaScript, AJAX, or PHP codes) representing an action or activity. As an example and not by way of limitation, a third-party webpage may include a selectable icon such as “like,” “check-in,” “eat,” “recommend,” or another suitable action or activity. A user viewing the third-party webpage may perform an action by selecting one of the icons (*e.g.*, “check-in”), causing a client system **130** to send to

social-networking system **160** a message indicating the user's action. In response to the message, social-networking system **160** may create an edge (*e.g.*, a check-in-type edge) between a user node **202** corresponding to the user and a concept node **204** corresponding to the third-party webpage or resource and store edge **206** in one or more data stores.

[0078] In particular embodiments, a pair of nodes in social graph **200** may be connected to each other by one or more edges **206**. An edge **206** connecting a pair of nodes may represent a relationship between the pair of nodes. In particular embodiments, an edge **206** may include or represent one or more data objects or attributes corresponding to the relationship between a pair of nodes. As an example and not by way of limitation, a first user may indicate that a second user is a "friend" of the first user. In response to this indication, social-networking system **160** may send a "friend request" to the second user. If the second user confirms the "friend request," social-networking system **160** may create an edge **206** connecting the first user's user node **202** to the second user's user node **202** in social graph **200** and store edge **206** as social-graph information in one or more of data stores **164**. In the example of **FIG. 2**, social graph **200** includes an edge **206** indicating a friend relation between user nodes **202** of user "A" and user "B" and an edge indicating a friend relation between user nodes **202** of user "C" and user "B." Although this disclosure describes or illustrates particular edges **206** with particular attributes connecting particular user nodes **202**, this disclosure contemplates any suitable edges **206** with any suitable attributes connecting user nodes **202**. As an example and not by way of limitation, an edge **206** may represent a friendship, family relationship, business or employment relationship, fan relationship (including, *e.g.*, liking, etc.), follower relationship, visitor relationship (including, *e.g.*, accessing, viewing, checking-in, sharing, etc.), subscriber relationship, superior/subordinate relationship, reciprocal relationship, non-reciprocal relationship, another suitable type of relationship, or two or more such relationships. Moreover, although this disclosure generally describes nodes as being connected, this disclosure also describes users or concepts as being connected. Herein, references to users or concepts being connected may, where appropriate, refer to the nodes corresponding to those users or concepts being connected in social graph **200** by one or more edges **206**.

[0079] In particular embodiments, an edge **206** between a user node **202** and a concept node **204** may represent a particular action or activity performed by a user associated with user

node **202** toward a concept associated with a concept node **204**. As an example and not by way of limitation, as illustrated in **FIG. 2**, a user may “like,” “attended,” “played,” “listened,” “cooked,” “worked at,” or “watched” a concept, each of which may correspond to an edge type or subtype. A concept-profile page corresponding to a concept node **204** may include, for example, a selectable “check in” icon (such as, for example, a clickable “check in” icon) or a selectable “add to favorites” icon. Similarly, after a user clicks these icons, social-networking system **160** may create a “favorite” edge or a “check in” edge in response to a user’s action corresponding to a respective action. As another example and not by way of limitation, a user (user “C”) may listen to a particular song (“Imagine”) using a particular application (SPOTIFY, which is an online music application). In this case, social-networking system **160** may create a “listened” edge **206** and a “used” edge (as illustrated in **FIG. 2**) between user nodes **202** corresponding to the user and concept nodes **204** corresponding to the song and application to indicate that the user listened to the song and used the application. Moreover, social-networking system **160** may create a “played” edge **206** (as illustrated in **FIG. 2**) between concept nodes **204** corresponding to the song and the application to indicate that the particular song was played by the particular application. In this case, “played” edge **206** corresponds to an action performed by an external application (SPOTIFY) on an external audio file (the song “Imagine”). Although this disclosure describes particular edges **206** with particular attributes connecting user nodes **202** and concept nodes **204**, this disclosure contemplates any suitable edges **206** with any suitable attributes connecting user nodes **202** and concept nodes **204**. Moreover, although this disclosure describes edges between a user node **202** and a concept node **204** representing a single relationship, this disclosure contemplates edges between a user node **202** and a concept node **204** representing one or more relationships. As an example and not by way of limitation, an edge **206** may represent both that a user likes and has used at a particular concept. Alternatively, another edge **206** may represent each type of relationship (or multiples of a single relationship) between a user node **202** and a concept node **204** (as illustrated in **FIG. 2** between user node **202** for user “E” and concept node **204** for “SPOTIFY”).

[0080] In particular embodiments, social-networking system **160** may create an edge **206** between a user node **202** and a concept node **204** in social graph **200**. As an example and not by way of limitation, a user viewing a concept-profile page (such as, for example, by using a web

browser or a special-purpose application hosted by the user's client system **130**) may indicate that he or she likes the concept represented by the concept node **204** by clicking or selecting a "Like" icon, which may cause the user's client system **130** to send to social-networking system **160** a message indicating the user's liking of the concept associated with the concept-profile page. In response to the message, social-networking system **160** may create an edge **206** between user node **202** associated with the user and concept node **204**, as illustrated by "like" edge **206** between the user and concept node **204**. In particular embodiments, social-networking system **160** may store an edge **206** in one or more data stores. In particular embodiments, an edge **206** may be automatically formed by social-networking system **160** in response to a particular user action. As an example and not by way of limitation, if a first user uploads a picture, watches a movie, or listens to a song, an edge **206** may be formed between user node **202** corresponding to the first user and concept nodes **204** corresponding to those concepts. Although this disclosure describes forming particular edges **206** in particular manners, this disclosure contemplates forming any suitable edges **206** in any suitable manner.

Establishing Wireless Communication Sessions with Beacons

[0081] Particular embodiments facilitate the exchange of information between a user and a third-party content provider via a beacon or other suitable geographic-positioning-capable devices or systems associated with the third-party content provider. As used herein, beacons may be any static or dynamic devices suitable for establishing and maintaining a wireless communication session between the beacon and any number of client systems proximate to the beacon. Beacons may be communicatively-coupled to at least one third-party content provider (*i.e.*, a beacon holder) and able to communicate wirelessly with a social-networking system. Beacons may send and receive wireless communications via, for example, radio-frequency identification, near-field communication, ultrasonic waves, BLUETOOTH, BLUETOOTH low energy, IBEACON protocols, or any other suitable wireless communication method, particularly short-range wireless communication methods (e.g., less than approximately 300 feet). Beacons may be touch-sensitive so as to detect when a user or client system makes contact with the surface of the beacon and to establish a wireless communication session in response to the detected touch. Beacons may have any of the hardware or software features of the types

described in U.S. Patent Application No. 14/460,886, titled “Bluetooth Crowd-Sourced Triangulation,” filed 15 August 2014; U.S. Patent Application No. 14/460,880, titled “Bluetooth Transmission Security Pattern,” filed 15 August 2014; and U.S. Patent Application No. 14/460,891, titled “Bluetooth Beacon Protocol,” filed 15 August 2014; U.S. Patent Application No. 13/416,975, titled “Dynamic Processor Duty Cycle Determination Based on Geographic Positioning Signals,” filed 9 March 2012; U.S. Patent Application No. 13/417,013, titled “Location Tracking for Geographic Positioning Capable Devices,” filed 9 March 2012; and U.S. Patent Application No. 13/431,842, titled “Dynamic Geographic Beacons for Geographic Positioning Capable Devices,” filed 27 March 2012, each of which is incorporated by reference herein in its entirety. A third-party content provider may be associated with multiple beacons, and each beacon may be fixed, removably or permanently, at a location within a place of the third-party content provider. For example, the third-party content provider may be a grocery store, and there may be a beacon at the end of each aisle and at each check-out line. When a user’s client system comes into range of a beacon or makes contact with a beacon (*e.g.*, the user taps the beacon with her client system), a wireless communication session (or other suitable association) may be established between the client system and the beacon. The wireless communication session may be automatically established or an additional level of confirmation may be required before the wireless communication session is established between the client system and a beacon. Although this disclosure describes establishing a wireless communication session in a particular manner, this disclosure contemplates establishing any suitable wireless communication session in any suitable manner.

[0082] In particular embodiments, once the wireless communication session has been established between a beacon and a user’s client system, social-networking information of the user may be provided to a third-party content provider with which the beacon is associated. For example and not by way of limitation, social-networking information of the user may include demographic information, geographic information, user preferences, any other suitable social-networking information, or any combination thereof. The social-networking information may be sent by the social-networking system to the third-party system directly or via the beacon. After receiving the social-networking information, the third-party content provider may tailor content to a particular user based on the received social-networking information. For example and not by

way of limitation, in response to receiving social-networking information indicating that it is a user's birthday, a third-party content provider (*e.g.*, a coffee shop) may send to the user's client system, via the beacon, an offer for a birthday gift (*e.g.*, a free cup of coffee). As another example, in response to receiving social-networking information including a user's purchase history, which indicates that the user always buys a particular product (*e.g.*, oxfords) when patronizing the third-party content provider (*e.g.*, a shoe store), the third-party content provider may send directly to the user's client system information about new products relevant to the user's buying habits (*e.g.*, a new style of oxfords that it only recently started carrying). As another example, the third-party system may send information for the user to the social-networking system, which may, in turn, send the information to the user's client system (*e.g.*, the social-networking system may present the information on a page corresponding to the third-party content provider). Although this disclosure describes providing social-networking information and third-party content in a particular manner, this disclosure contemplates providing any suitable social-networking information and any suitable third-party content in any suitable manner.

[0083] FIG. 3 illustrates an example beacon environment 300 associated with a social-networking system 160. Beacon environment 300 includes a beacon 310, a client system 130, a social-networking system 160, and a third-party system 170, each connected to a network 110. Client system 130 and social-networking system 160 are shown as connected to each other by beacon 310. Although FIG. 3 illustrates a particular arrangement of beacon 310, client system 130, social-networking system 160, third-party system 170, and network 110, this disclosure contemplates any suitable arrangement of beacon 310, client system 130, social-networking system 160, third-party system 170, and network 110. As an example and not by way of limitation, client system 130 and social-networking system 160 may be connected to each other directly or via network 110, bypassing beacon 310. Although FIG. 3 illustrates one beacon 310, there may be any suitable number of beacons 310. As described above, in connection with FIG. 1, links 150 may connect beacon 310, client system 130, social-networking system 160, and third-party system 170 to network 110 or to each other.

[0084] In particular embodiments, a wireless communication session (or other suitable association) may be established between client system 130 and beacon 310. Beacon 310 may be

situated at a designated location within a place (*e.g.*, a business) of a third-party content provider associated with third-party system **170**. For example, beacon **310** may be positioned at an entrance of a third-party content provider's store. When a client system **130** comes within a wireless communication range of beacon **310** (*i.e.*, a user associated with client system **130** moves into range of beacon **310**), third-party system **170** may send, via beacon **310**, a request to associate with client system **130**. Third-party system **170** may be communicatively coupled to beacon **310**. The request to associate may be a request to establish a wireless communication session between beacon **310** and client system **130**. In order for the request to associate to be sent, client system **130** may need to be proximate to beacon **310**. As used herein, proximate to the beacon refers to within a predetermined distance of beacon **310**. As an example and not by way of limitation, client system **130** may need to be inside the third-party content provider's business, at which beacon **310** is located, before the request to associate may be sent. It will be understood that the request to associate is described herein as being sent by third-party system **170**, via beacon **310**, for illustrative purposes and not by way of limitation and that the request to associate may be sent by any suitable components, including, for example, beacon **310**, third-party system **170**, client system **130**, and social-networking system **160**.

[0085] In particular embodiments, the third-party content provider may be associated with a plurality of beacons **310**, and each beacon **310** may be at a particular location within a place. For example, the third-party content provider may be a clothing retail store, and it may have a beacon **310** in each department (*e.g.*, three beacons **310**, one in each of the women's, men's, and children's departments). If client system **130** is proximate to more than one beacon **310** (*e.g.*, beacons **310** have overlapping ranges), various techniques may be used to determine with which of the beacons **310** client system **130** should be associated (*e.g.*, by establishing a wireless communication session) or to confirm a proposed wireless communication session with a particular beacon **310**. As an example and not by way of limitation, techniques for selecting one of beacons **310** may include user choice (*e.g.*, user input at client system **130** indicating proximity to a particular beacon **310**), probability (*e.g.*, probabilistic determination that user should be associated with a particular beacon **310**), location triangulation (*e.g.*, triangulating precise position of client system **130**, beacon **310**, or both), other location services of client system **130** (*e.g.*, network location), and confirmation via connections in social graph **200** (*e.g.*,

based on wireless communication sessions of connections). A request to associate may need to be complemented by one of these techniques before a wireless communication session may be established between beacon **310** and client system **130**. For example, client system **130** may be detected by multiple beacons **310**, and social-networking system **160** may determine that one or more other users, each within a threshold degree of separation from the user of client system **130** in social graph **200**, are associated with client systems **130** that are each in a wireless communication session with a particular beacon **310**. Social-networking system **160** may then determine that client system **130** should be in a wireless communication session with the same particular beacon **310**. As another example and not by way of limitation, user input at client system **130** may be used to confirm or to permit a wireless communication session with beacon **310** or to confirm with which of beacons **310** a wireless communication session should be established. Third-party system **170** (or social-networking system **160**) may send, directly or via beacon **310**, a prompt to client system **130**, asking a user to confirm, permit or deny a proposed wireless communication session with a particular beacon **310**. As an example and not by way of limitation, third-party system **170** (or social-networking system **160**) may send, directly or via beacon **310**, a prompt to client system **130** of a first user, asking a user to confirm a proposed wireless communication session pending between a client system **130** of a second user and a beacon **310**.

[0086] In particular embodiments, a beacon **310** that has been stolen, spoofed, or otherwise moved without authorization may be detected based on confirmed wireless communication sessions established between one or more client systems **130** and the stolen or spoofed beacon **310**. As an example and not by way of limitation, if a wireless communication session between beacon **310** and client system **130** has been established and confirmed (*e.g.*, via one or more of the above-described techniques), but the wireless communication session indicates that beacon **310** is at a location other than its designated location, then beacon **310** may be determined to be stolen or spoofed. Detecting a stolen or spoofed beacon **310** may be based on crowd-sourced information. For example, beacon **310** may be determined to be stolen or spoofed only after a threshold number of client systems **130** are in confirmed wireless communication sessions with beacon **310** at a wrong location. Once detected, the theft or spoof

of beacon **310** may be reported to a page administrator for a page associated with beacon **310** (e.g., a page hosted by social-networking system **160**).

[0087] In particular embodiments, a wireless communication session between beacon **310** and client system **130** may be established in response to beacon **310** being tapped by, or otherwise physically contacted by, client system **130**. A user may specify in a set of permissions whether wireless communication sessions may be established via tapping beacon **310**. A user may also specify, in a set of permissions, beacons **310** with which a wireless communication session may be automatically established (i.e., no further action need be taken by client system **130** to confirm or to allow the establishment of the wireless communication session) and for how long the permissions are valid (e.g., the wireless communication session may be automatically established only for a week or indefinitely).

Provision of Social-Networking Information to a Third-Party System

[0088] Once a wireless communication session has been established between client system **130** of a first user and beacon **310**, social-networking system **160** may provide a set of social-networking information to third-party system **170**, client systems **130** of other users (e.g., social connections of the first user in social graph **200**), other beacons **310**, other social-networking systems **160**, any other suitable recipient, or any combination thereof. Social-networking system **160** may directly share a set of social-networking information with a recipient, or the information may be shared by way of beacon **310**. It will be understood that although the set of social-networking information is described as being provided by social-networking system **160**, this is merely for illustrative purposes, not by way of limitation, and that any suitable components, devices, or systems may provide the set of social-networking information **160**, including, for example one or more beacons **310**.

[0089] Social-networking information of a user may include, for example and not by way of limitation, demographic information (e.g., age, gender, nationality, race, ethnicity, and locality), biographic information (e.g., name, picture, birthday, and astrological sign), preferences (e.g., music, book, movie, and food preferences), payment credentials, purchase history, loyalty points or credits, allergies and other medical information, social-graph information (e.g., social connections within a threshold degree of separation in social graph **200**

and social-networking information of those connections), any other information stored in a profile of the user on social-networking system **160**, any other suitable information pertaining to the user, or any combination thereof. As an example and not by way of limitation, the set of social-networking information received by third-party system **170** may include a connection between a first node in social graph **200** corresponding to a user of client system **130** and a second node corresponding to the third-party content provider. The connection between the first node and the second node may represent a particular social-networking action taken by the user with respect to the third-party content provider (*e.g.*, the user has “liked” or checked-in at a page or event associated with the third-party content provider on an online social network). As another example and not by way of limitation, the set of social-networking information received by third-party system **170** may include identifiers of one or more second users who are connected to a first user of client system **130** in social graph **200** by a threshold degree of separation (*e.g.*, first-degree connections may be “friends” of the first user).

[0090] In particular embodiments, a second set of social-networking information may be sent by social-networking system **160** and received by third-party system **170**. The second set of social-networking information may include social-networking information of one or more second users of the online social network, each of whom is connected to the first user of client system **130** by a threshold degree of separation. The second set of social-networking information may include social-networking information of the second users who are associated with client systems **130** that are located within wireless communication range of beacon **310**. As an example and not by way of limitation, social-networking system **160**, third-party system **170**, or beacon **310** may specify at least one radius delineating a distance around beacon **310**, and the second set of social-networking information may be of second users who are associated with client systems **130** that are located within the at least one radius of beacon **310**.

[0091] In particular embodiments, the particular set of social-networking information provided or received may be tailored to the particular recipient. The request to associate may specify at least one attribute of the third-party content provider. The particular social-networking information provided to third-party system **170** may be selected based on the at least one attribute of the third-party content provider. The attribute may be a type of good purveyed or service rendered by the third-party content provider, and the social-networking information

provided may include user preferences associated with the type of good or service. As an example and not by way of limitation, an attribute for a third-party content provider may indicate that it is a restaurant, and social-networking information sent to third-party system 170 may include a list of the user's allergies; whereas, an attribute for a third-party content provider may indicate that it is a clothing retail establishment, and social-networking information sent to third-party system 170 may include the user's clothing size and favorite color.

[0092] In particular embodiments, the particular set of social-networking information of a user that is sent or received may be subject to a set of permissions (e.g., privacy preferences) specified by the user or other restrictions imposed by the online social network. The social-networking information of a user may be automatically shared with beacon 310 or third-party system 170 in accordance with a user-specified set of permissions. For example, a user may specify that sharing is permitted for a particular branch of a third-party content provider or for all branches of the third-party content provider (e.g., sharing may be permitted for a local coffee shop or across all coffee shops in a franchise). As another example and not by way of limitation, a user may specify that sharing is permitted based on social-graph information (e.g., sharing may be permissive with entities for which the user has indicated an affinity via a "like," "follow," or other social-networking action). The set of permissions may permit sharing of certain social-networking information of the user based on social-graph information (e.g., connections within a threshold degree of separation). As an example and not by way of limitation, the set of permissions may allow a set of social-networking information to be sent based on a degree of separation in social graph 200 between a node corresponding to the third-party content provider and a node corresponding to the user of client system 130. The user may specify different levels of sharing within a set of permissions. As an example and not by way of limitation, the user may specify that a greater amount of social-networking information may be shared with first degree connections of the user in social graph 200 than the amount shared with second or greater degree connections.

Provision of Customized Third-Party Content to a Client System

[0093] In particular embodiments, in response to the provision of social-networking information of the user, third-party system 170 may push, feed, promote, or otherwise send third-

party content to the user's client system **130**. In particular embodiments, third-party system **170** may send third-party content intended for the user to social-networking system **160**, which may send the third-party content to the user's client system **130**. Third-party content may also be sent in response to a wireless communication session being established between beacon **310** and client system **130**, regardless of whether social-networking information of the user is provided. The third-party content provided may be customized based on the social-networking information received. As an example and not by way of limitation, in response to receiving a user's name, a third-party content provider may send the user's purchase history (*e.g.*, when the user was last at the third-party content provider business and what the user ordered or purchased). Third-party content may include, for example and not by way of limitation, identifiers of objects (*e.g.*, an indication that a particular object is located near beacon **310**), identifiers of users (*e.g.*, an indication that one or more client systems of one or more users are in wireless communication sessions with one or more beacons **310**), sponsored content (*e.g.*, an advertisement, coupon, promotion, or other suitable offer), patronage demographic information (*e.g.*, an average age of current or historical patrons of a third-party content provider place), messages (*e.g.*, messages from a third-party content provider or messages left by another user's client system **130**), information or directions regarding how to send the third-party content provider a message (*e.g.*, contact information for sending a message to third-party system **170**), access to or instructions for accessing a bulletin board or chat room feature (*e.g.*, access to a chat room with other users associated with client systems in wireless communication sessions with one or more beacons **310** of a particular third-party content provider), social-networking information (*e.g.*, of other users currently proximate to one or more beacons **310**), third-party content provider place information (*e.g.*, a map of a place or product stock information), any other suitable third-party content, or any combination thereof.

[0094] As an example and not by way of limitation, social-networking system **160** may suggest social-networking actions based on social-networking information (*e.g.*, suggest other users for tagging in a post at place of business associated with beacon **310** if the other users are associated with client systems **130** currently in wireless communication sessions with beacon **310**). As an example and not by way of limitation, third-party system **170** may send one or more identifiers of second users of an online social network to client system **130** of a first user, and the

second users may be each associated with a respective client system **130** that is in an active wireless communication session with beacon **310** (e.g., identifiers of second users currently at a third-party content provider place). Third-party system **170** may determine that the first user has one or more attributes in common with the second users based on received social-networking information of each and may provide the identifiers of the second users to the first user along with suggested conversation topics based on the social-networking information of each (e.g., the suggested conversation topics may be related to the identified commonalities). In the same example, third-party system **170** may only send the identifiers of second users who are social connections of the first user in social graph **200** (i.e., the second users are “friends” of the first user) based on the social-networking information of the first user. The third-party content may be based on current information, historical information, or a combination of both.

[0095] In particular embodiments, third-party system **170**, social-networking system **160**, or beacon **310** may send one or more questions or requests for additional information to client system **130** of a user. A response may be inputted by the user or otherwise inputted at client system **130** and sent by client system **130**, directly or via beacon **310**, to the questioning third-party system **170**, social-networking system **160**, or beacon **310**. The response sent may include a binary yes/no response or some or all of the requested information. As an example and not by way of limitation, the user may take and send a “selfie” or other image in response to a prompt asking for a photograph of the user at the third-party content provider place, as shown below in **FIG. 12**. Third-party system **170**, social-networking system **160**, or beacon **310** may then send third-party content to client system **130** based on the received user response. As an example and not by way of limitation, third-party system **170** may send the user a question—“Are you looking for jeans?”—and a selection of answers—“yes” and “no”—and in response to a user response of “yes,” third-party system **170** may send client system **130** a store map showing the location of jeans. In the same example, third-party system **170** may additionally receive social-networking information of the user indicating the gender of the user, and third-party system **170** may then further customize the third-party content to send the user’s client system **130** a map showing the location of jeans for the user’s gender. In particular embodiments, third-party system **170** may send the customized third-party content to social-networking system **160** for delivery to the user’s client system **130**. Social-networking system **160** may then provide the customized third-

party content to client system **130** (*e.g.*, by presenting it on a page corresponding to the third-party content provider).

[0096] In particular embodiments, third-party content may be sent to client system **130** while an established wireless communication session is active between beacon **310** and client system **130** (*i.e.*, while the user is presently located at the third-party content provider place). As an example and not by way of limitation, third-party content sent to client system **130** may include a promotional offer, which is redeemable by the user of client system **130** while an established wireless communication session between beacon **310** and client system **130** remains active. Additionally or alternatively, third-party content may be provided after a wireless communication session between beacon **310** and client system **130** has been terminated (*i.e.*, after a user has left the third-party content provider place). As an example and not by way of limitation, third-party system **130** may detect that a wireless communication session between beacon **310** and client system **130** has been terminated, and third-party system **170** may send third-party content to client system **130** while client system **130** is still within wireless communication range of beacon **310**. As an example and not by way of limitation, third-party system **170** may send a survey or a request to rate or review the third-party content provider to client system **130** after the wireless communication session between beacon **310** and client system **130** has been terminated (*e.g.*, by virtue of the user carrying client system **130** out of proximity of beacon **310** or by virtue of the wireless communication session expiring). As another example and not by way of limitation, social-networking system **160** may send a survey or a request to rate or review the third-party content provider to client system **130** after the wireless communication session between beacon **310** and client system **130** has been terminated.

[0097] In particular embodiments, the establishment of a wireless communication session between beacon **310** and client system **130** may effectuate a social-networking action in an online social network. As an example, the establishment of a wireless communication session between beacon **310** and client system **130** may result in a “like” of, check-in at, or other suitable expression of affinity for a page corresponding to the third-party content provider beacon-holder by the user on an online social network. Tapping or otherwise touching client system **130** to beacon **310** may perform a social-networking action (*e.g.*, “like,” “follow,” “poke,” or “send friend request”). As an example and not by way of limitation, beacon **310** may be associated with

a street-performer musician, and a user may tap beacon **310** with client system **130** to generate a “like” for a page corresponding to the musician on an online social network. Social-networking actions may be represented in social graph **200** by edges connecting a node corresponding to the user to a page corresponding to the third-party content provider or an event of the third-party content provider. Social-networking actions may be published by social-networking system **160** (e.g., on a feed or profile corresponding to the user). While the social-networking action is described as being triggered by the establishment of a wireless communication session between beacon **310** and client system **130**, it will be understood that this is merely illustrative and that any suitable interaction between beacon **310**, client system **130**, social-networking system **160**, and third-party system **170** may trigger the social-networking action. Social-networking actions performed via beacon **310** may be triggers for After-Party like reaction cards, which may be presented to a user, of the type described in U.S. Patent Application No. 14/466,269, titled “Generating Cards in Response to User Actions on Online Social Networks” filed 22 August 2014, the entirety of which is incorporated herein by reference. As an example and not by way of limitation, a social-networking action may be performed in response to a set of social-networking information of the user being sent to third-party system **170**. In particular embodiments, social-networking system **160** may present content to a user (e.g., by publishing objects and information in a feed on a page associated with the user on an online social network) based on wireless communication sessions established between the user’s client system **130** and beacons **310**. As an example and not by way of limitation, social-networking system **160** may rank stories, ads, promotions, offers, or other content in a feed based on the wireless communication sessions established between the user’s client system **130** and beacons **310**.

[0098] In particular embodiments, the establishment of a wireless communication session between beacon **310** and client system **130** may cause third-party system **170** to provide a deep link to a particular location or content item of an application of the third-party content provider with which beacon **310** is associated. As an example and not by way of limitation, third-party system **170** may receive social-networking information of a user indicating that the user is interested in a particular product, and third-party system **170** may send to the user’s client system **130** a deep link (e.g., a URL) to a location in an application (e.g., running on client device **130**) that has information pertaining to the particular product.

[0099] In particular embodiments, the establishment of a wireless communication session between beacon **310** and client system **130** may unlock third-party content (*e.g.*, a coupon), content of social-networking system **160** (*e.g.*, a key to access a VIP page on the online social network), or content deposited at beacon **310** by another user of an online social network (*e.g.*, a message, image, or digital gift). As an example and not by way of limitation, a first user may leave a message, physical or digital, at beacon **310** and may specify who may access the message (*e.g.*, any second user in a wireless communication session with beacon **310** or any second user who is a social connection of the first user and who is in a wireless communication session with beacon **310**).

[0100] In particular embodiments, authorization to access or view content deposited at one or more beacons **310** (*e.g.*, by a user, social-networking system **160**, or third-party system **170**) may be based on conditions set by the creator or depositor of the content or by another entity. A restrictive condition on access to certain content at one or more beacons **310** may include membership in a specified group. For example, authorized group members may include, by example and not by way of limitation: members of a certain social club; users who have purchased access rights to the particular content; direct connections of a particular user node or concept node in social graph **200**; users having phone numbers with a certain area code or prefix; registered users of a downloaded mobile device application, other suitable conditions, or any combination thereof. Restrictions to access may additionally be based on user-specific information, including but not limited to: demographic attributes of the user (*e.g.*, age, gender, nationality, race, ethnicity, and/or locality); profile attributes of the user on social-networking system **160**, social-networking information associated with the user (*e.g.*, friends within a threshold degree of separation of the user within social graph **200**); a status of the client system (*e.g.*, the device is in “pairing mode” or “game mode”); parental controls set for an account of the user with social-networking system **160**; a transaction history of the user; other suitable user-specific information; or any combination thereof. In an example, authorization may be granted to users having a transaction history showing greater than a threshold number of games played on an online social network; achievement of a threshold level within a particular game; greater than a threshold number of hours logged playing a particular game; achievement of greater than a threshold number of posts to a page associated with beacon **310** (*e.g.*, comments or status

updates); greater than a threshold number of wireless communication sessions established with a particular beacon **310** or set of beacons **310** (e.g., scavenger hunt specifying ten New York City destinations to visit within a year); or designation as an administrator or officer of an organization or group on an online social network. As an example and not by way of limitation, a third-party system **170** may grant access to third-party content or may provide third-party content (e.g., a promotion or other reward) to a user's client system **130** when greater than a threshold number of wireless communication sessions have been established between client system **130** and one or more beacons **310** of the third-party content provider.

[0101] In particular embodiments, a third-party content provider (or third-party system **170**) may act in real-time based on wireless communication sessions between beacon **310** and client system **130**, the received set or sets of social-networking information, received user responses to questions or requests for information, or any combination thereof. Third-party system **170** may cause one or more characteristics of a place of the third-party content provider to be modified, in real-time, in response to the received set of social-networking information of a user. As an example and not by way of limitation, the third-party content provider may perform an action customized to a particular user or group of users (e.g., change the lighting, offer a favorite appetizer, play a preferred genre of music, or any combination thereof, based on the received set or sets of social-networking information). As another example and not by way of limitation, the third-party content provider may seat a user based similarities or dissimilarities (e.g., one or more similar or dissimilar attributes) between the sets of social-networking information received for that user and the sets of social-networking information received for other users in the place (e.g., restaurant) of the third-party content provider.

Business Insights

[0102] In particular embodiments, session information of one or more users associated with one or more client systems **130** may be received by social-networking system **160** from one or more beacons **310** at locations in a place of a third-party content provider. Session information may include information pertaining to interactions between each client system **130** and beacons **310**. As an example and not by way of limitation, session information may include, for each user, a history of wireless communication sessions established between one of beacons **310** and client

system **130**; a number of visits (*i.e.*, wireless communication sessions established between one or more of beacons **310** and the respective client system **130**); whether a user is in a first-time wireless communication session with one of beacons **310** at a place of a third-party content provider; duration of each wireless communication session between one of beacons **310** and client system **130**; average duration of wireless communication session between beacons **310** and client system **130**; time since last wireless communication session was established between one of beacons **310** and client system **130**; any other information pertaining to wireless communication sessions established between one of beacons **310** and client system **130**; or any combination thereof. Session information may include information of users whose client systems **130** are presently in a wireless communication session with one or more of beacons **310**. Session information may also include information of users whose client systems **130** have previously been in a wireless communication session with one or more of beacons **310**.

[0103] In particular embodiments, social-networking system **160** may generate a report of business insights for a third-party content provider based on foot traffic registered by one or more beacons **310** situated at locations in a business of the third-party content provider. Although the report is described in **FIGS. 4A–4C** as being generated by social-networking system **160**, this is merely for illustrative purposes, not by way of limitation, and any suitable components, devices, or systems may generate the report, including, for example one or more beacons **310**. As an example and not by way of limitation, the report may include a set of business insights generated based on aggregated session information and aggregated social-networking information pertaining to a plurality of users of an online social network who are currently or were previously associated with the one or more beacons **310** of the third-party content provider, as described below in connection with **FIG. 4A**. As another example and not by way of limitation, the report may include a profile for each individual user of an online social network who is currently or was previously associated with the one or more beacons **310** of the third-party content provider, as described below in connection with **FIGS. 4B–4C**. An advantage of particular embodiments is that one or more business insights (*e.g.*, business insights based on beacons **310** associated with one or more third-party content providers) may be provided to users and customized to the particular needs of each particular user. In this manner, business insights may empower users, providing customized, location-based information based on which the users

may make informed decisions. As an example and not by way of limitation, aggregate business insights may include reported noise levels in local coffee shops (*e.g.*, so that the user may select the quietest coffee shop at which to study); demographic composition of bars in a particular area (*e.g.*, so that the user may select the bar with the most people of his age group); wait time at grocery stores (*e.g.*, so that the user may select the grocery store with the shortest checkout lines).

[0104] FIG. 4A illustrates an example report view 405 of an interface 400 displayed on a third-party system 130. Report view 405 may include any suitable business insights 420 (*e.g.*, statistics, data, or other suitable information) generated based on aggregated session information and aggregated social-networking information for one or more users of an online social network (*i.e.*, the clientele of a third-party content provider). After generating business insights 420, social-networking system 160 may send business insights 420 to third-party system 170 for display to the third-party content provider associated with third-party system 170. Business insights 420 may be generated for all users associated with client systems 130 previously in an established wireless communication session with any of beacons 310 (*i.e.*, historical customers). Business insights 420 may be generated for all users whose client systems 130 are currently in an active wireless communication session with any of beacons 310 (*i.e.*, current customers). Social-networking system 160 receive session information for one or more users from one or more beacons 310, each of which is communicatively coupled with third-party system 170 and associated with a particular third-party content provider. As an example and not by way of limitation, one or more beacons 310 may be fixed at one or more locations in a business of the third-party content provider. The received session information of a user may include an identifier of the particular user, and social-networking system 160 may access social-networking information based on the identifier. Social-networking system 160 may then aggregate and anonymize the received session information and the accessed social-networking information for one or more users in order to generate business insights 420. Business insights may be sent by social-networking system 160 to third-party system 170 for display at a specialized user interface 400 of a native application running on third-party system 170.

[0105] In particular embodiments, business insights 420 may be generated based on aggregated session information, aggregated social-networking information, or any combination

thereof. Business insights **420** generated based on session information may include, for example and not by way of limitation, average duration of user visits (*i.e.*, determined based on wireless communication session durations). Business insights **420** generated based on social-networking information may include, for example and not by way of limitation, a number of users who are female or products or menu items for which one or more users have indicated an affinity (*e.g.*, by “liking” in an online social network). Business insights **420** may also be generated based on both social-networking information and session information and may include, for example and not by way of limitation, a number of users who are female and who are currently in a wireless communication session with beacon **310** and an average duration of visits for female users. Social-networking system **160** may generate business insights **420** subject to sets of permissions of each user or other restrictions imposed by the social-networking system **160**. In the illustrated example of **FIG. 4A**, business insights **420** are shown as including customers in the store (*i.e.*, users with client systems **130** in wireless communication sessions with one or more beacons **310**), numbers of returning and first time customers, numbers of men and women, average minutes per visit, average visit per customer, combined loyalty points for all customers, average age, customers whose birthdays are today, average rating (*e.g.*, of a page corresponding to the third-party content provider on an online social network), and customers checked-in (*e.g.*, at a page corresponding to the third-party content provider on an online social network). The number of and the particular business insights **420** generated and included in report view **405** may be customized to a particular third-party content provider for which social-networking system **160** generates business insights **420**. In connection with business insights, particular embodiments may utilize one or more systems, components, elements, functions, methods, operations, or steps disclosed in U.S. Patent Application No. 14/542,389, titled “Visualizing Audience Metrics”; U.S. Patent Application No. 14/542,397, titled “Using Audience Metrics with Targeting Criteria for an Advertisement”; and U.S. Patent Application No. 14/452,411, titled “Generating Audience Metrics Including Affinity Scores Relative to an Audience”; each of which is incorporated by reference in its entirety herein.

[0106] In particular embodiments, a third-party content provider may have multiple beacons **310** dispersed throughout the third-party content provider’s place of business (*e.g.*, at check-out queues, departments, aisles, and displays for particular products). Session information

of one or more users received from each of beacons **310** by social-networking system **160** may include a location within the place for each of the one or more users based on the particular beacon **310** with which the user's client system **130** is in a wireless communication session. Business insights **420** may be generated based on this location information and may include "pain points," for example, a check-out with a long queue (*e.g.*, more than a threshold number of client systems **130** are currently in a wireless communication session with beacon **310** at the check-out), crowded department or aisles (*e.g.*, more than a threshold number of client systems **130** are currently in a wireless communication session with beacon **310** at the department or aisle), products near high volume foot traffic that may need to be restocked, and tables or users that require service, any other suitable business insights **420** based on users' locations within the business, or any combination thereof.

[0107] In particular embodiments, a third-party content provider or associated third-party system **170** may perform an action in real-time based on business insights **420**. As an example and not by way of limitation, third-party system **170** may route staff throughout the third-party content provider place of business based on business insights **420** (*e.g.*, business insights **420** may include department-to-checkout time, department traffic, and specific offer(s) in a particular department). As another example, third-party system **170** may price items based on business insights **420** (*e.g.*, surge-pricing based on business insight **420** indicating high traffic volume). As another example, third-party system **170** may reorder stock or re-stock shelves or products (*e.g.*, based on business insights **420** including aggregate purchase history of particular products). In another example, business insights **420** may also monitor the crowd index at a third-party content provider place of business (*e.g.*, based on average dwell time), and third-party system **170** may make suggestions to a user based on the business insights **420** tracking crowd index (*e.g.*, make suggestions of places a user may like based on the social-networking and session information of the particular user, if the third-party content provider's place of business is overcrowded).

[0108] Business insights **420** may be generated based on session information and social-networking information received or accessed during a pre-defined window of time, information continuously accumulated over time, or real-time information. Business insights may be dynamically updated in real-time. As an example and not by way of limitation, business insights

may be updated based on wireless communication sessions established and terminated between beacons **310** and client systems **130**. Business insights may be provided on an individual basis or as part of a report of multiple insights (*e.g.*, as shown in report view **405**). Business insights **420** may be monetized by charging third-party content providers for the generation and provision of a report of business insights **420**. The particular types of business insights provided in portfolios may be customized based on the needs and budget of a particular third-party content provider.

[0109] **FIG. 4B** illustrates example profile view **410** of an interface **400** displayed on a third-party system **130**. In particular embodiments, profile view **410** may include an individual profile, represented by profile icon **425**, for each of one or more users of an online social network. Profile view **410** may provide profile icons **425** in a random or pre-determined order. As an example and not by way of limitation, profile view **410** may provide profile icons **425** in ascending or descending order of duration of current visit, loyalty points, or in any other suitable order (*e.g.*, alphabetical by first name). Profiles icons **425** may be generated for all users associated with client systems **130** previously or currently in an established wireless communication session with any of beacons **310** based on the preferences of the particular third-party content provider. In the example illustrated in **FIG. 4B**, profile icons **425** may include an image or other representation of each of the users (*e.g.*, social-networking system **160** may access each user's social-networking information to obtain an image of the user). Profile icons **425** may include a user's name, identifier, moniker, or any other suitable identifying information. In another example, social-networking system **160** may cause notification jewels **435** to appear and persist on profile icons **425**. Notification jewel **435** may display a number corresponding to, for example and not by way of limitation, new information received for a user (*e.g.*, social-networking information). In the example illustrated in **FIG. 4B**, notification jewels **435** depict the numerals "8," "11," and "2," and may refer to the number of visits for each user associated with profile icons **425**. Profile icons **425** and notification jewels **435** are customizable by social-networking system **160** according to the preferences of a third-party content provider. Profile icons **425** may be selectable to reveal a detailed view, which is described below in connection with **FIG. 4C**.

[0110] **FIG. 4C** illustrates an example detailed profile view **415** of an interface **400** displayed on a third-party system **130**. Detailed profile view **415** may include profile icons **425**

and notification jewels 435. Once a profile icon 425 has been selected (*e.g.*, via input at third-party system 160), it may expand to reveal user profile 445, which may include a set of social-networking information and session information of a particular user. In the example illustrated in FIG. 4C, a particular profile icon 425 is shown as expanded, including profile picture 430 and user profile 445, which may hover or float over profile icons 425. Profile picture 430 may be the same image or a different image than that depicted in profile icon 425. User profile 445 may include user name 440 (*e.g.*, “John”) and any other social-networking information or session information of the user (*e.g.*, “age: 25”). User profile 445 may also include social-networking actions of the user taken with respect to a node in social graph 200 corresponding to a third-party content provider. As an example and not by way of limitation, user profile 445 may include a user social-networking action expressing affinity for the third-party content provider, which may be represented in social graph 200 by an edge connecting a first node corresponding to the user to a second node corresponding to the third-party content provider. User profile 445 may also include a notes section editable at third-party system 170 to include any pertinent notes of third-party content provider employees or agents.

[0111] In particular embodiments, social-networking system 160 may store a record of session information received for one or more users, social-networking information accessed for the one or more users, third-party information received, and any other relevant information. Social-networking system 160 may store this information, for example, as a markup of a user profile on an online social network (*e.g.*, stored in association with a corresponding user node in social graph 200). As an example and not by way of limitation, the markup of a user profile may be accessible to third-party system 170 by calling one or more APIs.

[0112] Although this disclosure describes and illustrates particular embodiments of FIGS. 4A–4C as being implemented by social-networking system 160, this disclosure contemplates any suitable embodiments of FIGS. 4A–4C occurring on any suitable interface and as being implemented by any suitable platform or system. As an example, and not by way of limitation, particular embodiments of FIGS. 4A–4C may be implemented by one or more beacons 310. Furthermore, although this disclosure describes and illustrates particular components, devices, or systems carrying out particular steps of the method of FIGS. 4A–4C,

this disclosure contemplates any suitable combination of any suitable components, devices, or systems carrying out any suitable steps of the method of **FIGS. 4A–4C**.

Ad-Targeting

[0113] **FIG. 5** illustrates example ads **510** of a third-party content provider displayed at an interface **500** of a client system **130**. In particular embodiments, social-networking system **160** may target users for advertisements and customize advertisements to be sent to the user based on session information, social-networking information, and sponsored content received from third-party system **170**. Social-networking system **160** may receive session information for a user from one or more beacons **310**, each of which is communicatively coupled with third-party system **170** and associated with a particular third-party content provider. The received session information of a user may include an identifier of the particular user, and social-networking system **160** may access social-networking information based on the identifier. Social-networking system **160** may also receive, from third-party system **170**, sponsored content. Sponsored content may include, for example and not by way of limitation, an advertisement, a coupon, an offer, a discount, a promotion, any other suitable advertising content, or any combination thereof. Social-networking system **160** may generate and send ads **510** to the user's client system based on a set of permissions specified by the user.

[0114] Social-networking system **160** may send ads **510** to client system **130** via text, email, or any other suitable method of wireless communication based on a set of permissions specified by the user of the client system **130**. In the example illustrated in **FIG. 5**, ads **510** are shown as text messages, and the user of client system **130** may have indicated that text message is the preferred mode of communication for all advertising content. Social-networking system **160** may also provide ads **510** to users in a feed or otherwise published on an online social network. Ads **510** may be sent to a user while his client system **130** is presently in an established wireless communication session with beacon **310** (*e.g.*, an offer or discount redeemable during the current wireless communication session) or after the wireless communication session between beacon **310** and client system **130** has been terminated. As an example and not by way of limitation, social-networking system **160** may send an offer to a user if that user used to frequent the business (*e.g.*, determined based on session information) but a predetermined period

of time has passed since a wireless communication session has been established between beacon **310** and client system **130** of the user.

[0115] In particular embodiments, social-networking system **160** may determine to which user to send ads **510** and how to customize ads **510** based on that user's social-networking information and session information. Social-networking system **160** may send ads based on one or more affinities expressed by the user. As an example and not by way of limitation, the social-networking information of the user may include an affinity coefficient of a first node corresponding to the user with respect to one or more second nodes in social graph **200**. As an example, the affinity coefficient may be based on one or more edges connecting the first node to one or more second nodes corresponding to the third-party content provider. Social-networking system **160** may send ads **510** based on a current geographical location of a user (e.g., determined based on the social-networking information). As an example and not by way of limitation, social-networking system **160** may send an ad **510** for a particular third-party content provider to which the user is currently proximate. As an example and not by way of limitation, social-networking system **160** may send ads **510** to client system **130** in response to determining, based on session information of the user, that a wireless communication session has not been established between beacon **310** and client system **130** for a predetermined period of time. As another example and not by way of limitation, social-networking system **160** may send ads **510** to client system **130** in response to determining, based on social-networking information of the user, that the user's purchase history indicates a strong trend to purchasing a particular type of product when it is on-sale and the sponsored content received includes a discount for the same type of product. As an example and not by way of limitation, social-networking system **160** may send ads **510** to a user because he visited a third-party content provider before other users visited the third-party content provider (*i.e.*, the user's client system was in a wireless communication system with a beacon **310** at an earlier date or time than a certain number of other users' client systems). As an example and not by way of limitation, social-networking systems **160** may send ads **510** (e.g., a VIP promotional offer) to a user who performed a social-networking action with respect to a node corresponding to a third-party content provider in social graph **200** before other users did the same (e.g., the user is an "early adopter").

[0116] In particular embodiments, social-networking system **160** may send ads **510** to client system **130** of a first user based on the social-networking information of one or more second users. As an example and not by way of limitation, social-networking system **160** may send ads **510** to client system **130** of a first user who has one or more attributes (*e.g.*, received session information may include the one or more attributes) in common with one or more second users whose social-networking information and session information indicates a particular average duration of visits, a threshold frequency of visits, a particular purchase history, any other suitable attributes, or any combination thereof (*e.g.*, the first user is targeted for advertising based on being a “lookalike” of second users who are frequent or loyal patrons of a particular third-party content provider). Social-networking system **160** may also send ads **510** to client system **130** of a first user based on the social-networking information and session information of one or more second users who are connected to the first user in social graph **200** (*e.g.*, a first node corresponds to the first user, second nodes correspond to the second users, and the first node is connected to each of the second nodes by a threshold degree of separation). Advertisements may be sent to particular users and customized for particular users using one or more systems, components, elements, functions, methods, operations, or steps disclosed in U.S. Patent Application No. 14/300,309, titled “Selecting Advertisement Content for Social Networking System Users Based on Types of Location Data”; U.S. Patent Application No. 14/529,133, titled “Selection Of A Group Of Content Items For Presentation To An Online System User Based On Content Item Characteristics And User Attributes”; and U.S. Patent Application No. 14/305,997, titled “Displaying Advertisements with Location Information”; each of which is incorporated by reference in its entirety herein.

[0117] In particular embodiments, client system **130** may be currently in a wireless communication session with beacon **310** of a first third-party content provider, and social-networking system **160** may send ads **510**, which are based on sponsored content received from a second third-party content provider. In particular embodiments, social-networking system **160** may generate new sponsored content or receive sponsored content from an entity or third-party content provider that is not associated with a beacon **310**. In particular embodiments, social-networking system **160** may receive sponsored content from third-party systems **170** of multiple third-party content providers, and social-networking system may select sponsored content

received from at least one of the third-party systems **170**, based on which social-networking system **160** may generate ads **510** to be sent to client system **130**. As an example and not by way of limitation, if a third-party content provider place of business reaches a threshold occupancy level (*e.g.*, based on a business insight crowd index), it may send ads **510**, which may promote different third-party content providers, to users who are presently associated with one or more beacons **310** in order to manage the crowd index. As another example and not by way of limitation, for a third-party content provider business (*e.g.*, Johnny Brenda's bar), social-networking system **160** may send ads **510** to client system **130** that include nearby suggested third-party content provider businesses and/or promotions or offers for the suggested third-party content provider businesses (*e.g.*, advertisement for happy hour at a nearby bar with similar attributes, the Starboard Side Tavern). Social-networking system **160** may also send ads **510** directing a user to a different third-party content provider business based on predicted exit times (*e.g.*, determined based of business insights including average duration of visits for the particular users) of users whose client systems are currently in a wireless communication session with one of beacons **310**. As an example and not by way of limitation, after a user's client system **130** has been in a wireless communication session with a beacon **310** for a predetermined period of time, social-networking system **160** may send ads **510** for other similar businesses or for other businesses to visit next (*e.g.*, if the third-party content provider is a bar, a next-visit business may be a pizza shop, or if the third-party content provider is a movie theater, a next-visit business may be a coffee shop). Social-networking system **160** may send ads **510** based on physical proximity of other third-party content providers (*e.g.*, within walking distance) as well as on social-networking information (*e.g.*, the user has indicated an affinity for a type of third-party content provider) and/or session information (*e.g.*, ads may include "Two of your friends are at Starboard Bar" or "Ten of your friends like Mystic Pizza, which is just across the street."). Social-networking system **160** may also send ads **510** to client system **130** based trends observed in the user's session information (*e.g.*, user has an established pattern of frequenting a second third-party content provider after a first third-party content provider, so the second third-party content provider may be promoted as a next-visit business).

[0118] In particular embodiments, advertising may be monetized by taking bids from third-party content providers for an advertising slot. For example, in response to receiving, from

a third-party content provider at which a user is located, sponsorship information soliciting sponsored content from one or more other third-party content providers, social-networking system **160** may receive sponsored content from the one or more other third-party content providers, each also sending a bid, either in real-time or via prior negotiation. As another example, social-networking system **160** may also receive sponsored content from an entity or third-party content provider that is not associated with a beacon **310**. Social-networking system **160** may send ads **510** to a client system **130** based on the sponsored content of the third-party content provider who submitted the winning bid. The sponsorship information may specify a time range (*e.g.*, based on an exit time prediction for a particular user), and social-networking system **160** may send ads **510** to client system **130** during the specified time range. As an example and not by way of limitation, transportation entities (*e.g.*, taxi services) may also submit bids and sponsored content (*e.g.*, taxi services or other third-party transit providers may bid on ads **510** to be sent to client systems **130** based on predicted exit times).

[0119] Although this disclosure describes and illustrates particular embodiments of **FIG. 5** as being implemented by social-networking system **160**, this disclosure contemplates any suitable embodiments of **FIG. 5** occurring on any suitable interface and as being implemented by any suitable platform or system. As an example, and not by way of limitation, particular embodiments of **FIG. 5** may be implemented by one or more beacons **310**. Furthermore, although this disclosure describes and illustrates particular components, devices, or systems carrying out particular steps of the method of **FIG. 5**, this disclosure contemplates any suitable combination of any suitable components, devices, or systems carrying out any suitable steps of the method of **FIG. 5**.

[0120] **FIG. 6** illustrates an example method **600** for sending customized third-party content to a client system **130**. The method may begin at step **610**, where third-party system **170** may send, from third-party system **170** associated with a third-party content provider, via beacon **310** associated with the third-party content provider, beacon **310** being communicatively coupled to third-party system **170**, a request to associate with first client system **130** of a first user of an online social network, the request specifying at least one attribute of the third-party content provider, and wherein: beacon **310** is associated with a location within a place associated with the third-party content provider, and first client system **130** is within wireless communication

range of beacon **310**, first client system **130** being proximate to beacon **310**. At step **620**, third-party system **170** may receive, via beacon **310**, a first set of social-networking information of the first user, the first set of social-networking information being sent in response to establishment of a wireless communication session between beacon **310** and first client system **130**, wherein the first set of social-networking information is based on a set of permissions specified by the first user and the at least one attribute of the third-party content provider. At step **630**, third-party system **170** may send to first client system **130**, via beacon **310**, customized third-party content for display on first client system **130**, the customized third-party content being based on the first set of social-networking information and first client system **130** being proximate to beacon **310**. Particular embodiments may repeat one or more steps of the method of **FIG. 6**, where appropriate. Although this disclosure describes and illustrates particular steps of the method of **FIG. 6** as occurring in a particular order, this disclosure contemplates any suitable steps of the method of **FIG. 6** occurring in any suitable order. Moreover, although this disclosure describes and illustrates an example method for sending customized third-party content to client system **130** including the particular steps of the method of **FIG. 6**, this disclosure contemplates any suitable method for sending customized third-party content to client system **130** including any suitable steps, which may include all, some, or none of the steps of the method of **FIG. 6**, where appropriate. Furthermore, although this disclosure describes and illustrates particular components, devices, or systems carrying out particular steps of the method of **FIG. 6**, this disclosure contemplates any suitable combination of any suitable components, devices, or systems carrying out any suitable steps of the method of **FIG. 6**.

[0121] **FIG. 7** illustrates an example method **700** for sending a report to a third-party system **170**. The method may begin at step **710**, where social-networking system **160** may receive, from one or more beacons **310** associated with a third-party content provider, each beacon **310** being communicatively coupled to third-party system **170** associated with the third-party content provider, session information of a plurality of first users of the online social network, the session information including an identifier of each first user, wherein: each beacon **310** is associated with a particular location within a place associated with the third-party content provider, each first user is associated with a respective first client system **130**, each first client system **130** having been within wireless communication range of and proximate to a respective at

least one beacon **310**, and at least one wireless communication session has been established between the respective at least one beacon **310** and each first client system **130**. At step **720**, social-networking system **160** may access social-networking information associated with each first user based on the identifiers. At step **730**, social-networking system **160** may generate a report, the report including aggregated social-networking information and aggregated session information of one or more of the first users, wherein the report is generated based on sets of permissions specified by each of the one or more first users. At step **740**, social-networking system **160** may send the report to third-party system **170** for display. Particular embodiments may repeat one or more steps of the method of **FIG. 7**, where appropriate. Although this disclosure describes and illustrates particular steps of the method of **FIG. 7** as occurring in a particular order, this disclosure contemplates any suitable steps of the method of **FIG. 7** occurring in any suitable order. Moreover, although this disclosure describes and illustrates an example method for sending a report to third-party system **170** including the particular steps of the method of **FIG. 7**, this disclosure contemplates any suitable method for sending a report to third-party system **170** including any suitable steps, which may include all, some, or none of the steps of the method of **FIG. 7**, where appropriate. Furthermore, although this disclosure describes and illustrates particular components, devices, or systems carrying out particular steps of the method of **FIG. 7**, this disclosure contemplates any suitable combination of any suitable components, devices, or systems carrying out any suitable steps of the method of **FIG. 7**.

[0122] **FIG. 8** illustrates an example method **800** for sending a customized advertisement to a client system **130**. The method may begin at step **810**, where social-networking system **160** may receive, from beacon **310** associated with a third-party content provider, beacon **310** being communicatively coupled to third-party system **170** associated with the third-party content provider, session information of a first user of an online social network, the session information of the first user including an identifier of the first user, wherein: beacon **310** is associated with a first location of a plurality of locations within a place associated with the third-party content provider, and at least one wireless communication session has been established between first client system **130** of the first user and beacon **310**, first client system **130** having been proximate to beacon **310**. At step **820**, social-networking system **160** may receive sponsored content from third-party system **170** associated with the third-party content provider. At step **830**, social-

networking system **160** may access social-networking information of the first user based on the identifier. At step **840**, social-networking system **160** may send a customized advertisement to first client system **130** for display on first client system **130**, wherein the customized advertisement is based on the session information of the first user, the sponsored content, the social-networking information of the first user, and wherein the customized advertisement is sent to first client system **130** based on a set of permissions specified by the first user. Particular embodiments may repeat one or more steps of the method of **FIG. 8**, where appropriate. Although this disclosure describes and illustrates particular steps of the method of **FIG. 8** as occurring in a particular order, this disclosure contemplates any suitable steps of the method of **FIG. 8** occurring in any suitable order. Moreover, although this disclosure describes and illustrates an example method for sending a customized advertisement to client system **130** including the particular steps of the method of **FIG. 8**, this disclosure contemplates any suitable method for sending a customized advertisement to client system **130** including any suitable steps, which may include all, some, or none of the steps of the method of **FIG. 8**, where appropriate. Furthermore, although this disclosure describes and illustrates particular components, devices, or systems carrying out particular steps of the method of **FIG. 8**, this disclosure contemplates any suitable combination of any suitable components, devices, or systems carrying out any suitable steps of the method of **FIG. 8**.

Notifications

Third-Party Content Notifications

[0123] In particular embodiments, social-networking system **160** may generate and provide notifications to users of an online social network based on information received from beacon **310** or other suitable geographic-positioning-capable devices or systems associated with a third-party content provider. Social-networking system **160** may generate and provide to users notifications regarding a place of business of a third-party content provider and including third-party content. As an example and not by way of limitation, social-networking system **160** may determine, based on location information received from a user's client system, that the user is located near beacon **310**, which may be located at a place of a third-party content provider (*e.g.*, at a brick-and-mortar store for a particular clothing retailer). Social-networking system **160** may

then send to the user a notification including third-party content associated with the third-party content provider and place. Social-networking system **160** may generate and personalize notifications using any suitable information, including, for example, social-networking information and session information associated with the user and with other users to whom the user is connected in social graph **200** by less than a threshold degree of separation. As an example and not by way of limitation, social-networking system **160** may send the user a message notifying the user that he is close to a particular third-party content provider location that his friends like (*e.g.*, a number of first degree connections have “liked” a page corresponding to the third-party content provider on the online social network). The particular notifications sent to a user as well as when and how many notifications may be sent to a user may be subject to a set of permissions (*e.g.*, privacy preferences) specified by the user or other restrictions imposed by the online social network. Any suitable notifications may be sent by social-networking system **160** to client system **130** for display to the user, including, as an example and not by way of limitation, notifications to be presented on a lock screen of client system **130**, as described below in connection with **FIG. 9A**, notifications to be presented in an interface of an application (*e.g.*, a social media application) running on client system **130**, as described below in connection with **FIGS. 9B–9E**, other suitable types of notifications (*e.g.*, banner notifications, badge notifications, jewel notifications, messaging notifications, etc.), or any combination thereof.

[0124] **FIG. 9A** illustrates an example notification **910** displayed on a lock screen **905** of a client system **130**. In particular embodiments, social-networking system **160** may send notifications, including, for example, notification **910** to interface **900** of client system **130** of a user based on location information of the user. Location information may be sent to social-networking system **160**, as an example and not by way of limitation, by client system **130** (*e.g.*, using GPS functionality). As another example, location information may be determined by social-networking system **160** based on social-networking actions taken by the user (*e.g.*, the user checked-in at a page or event associated with a third-party content provider location). In particular embodiments, notifications may be deleted, retracted, or otherwise removed based on location information of the user of client system **130**. As an example and not by way of limitation, social-networking system **160** may determine to remove notification **910** because a user’s client system **130** has moved outside of the threshold distance from the location of beacon

310. Notifications may also be removed after a user has interacted with it by, for example, a slide gesture inputted at a touchscreen interface of client system **130**. Notifications may be dismissed in response to a predefined user input (*e.g.*, tapping a particular element of the interface).

[0125] In particular embodiments, notification **910** may include any suitable third-party content, and the particular third-party content included in notification **910** may be customized for the particular user using any suitable techniques, as described above. Notification **910** may also include any other suitable information that is associated with the third-party content provider (*e.g.*, from the social-networking system), which may also be customized for the particular user using any suitable techniques. In the embodiment illustrated in **FIG. 9A**, social-networking system **160** may determine that the user is within a threshold distance of Prince Street Cafe and may send notification **910** indicating that the user is nearby and that “people talk about red velvet cupcake and crumb pie here.” Social-networking system **160** may determine to send a notification to client system **130** of a particular user based on social-networking information of the user and on session information received from a beacon **310** and associated with the user’s client system **130**. As an example and not by way of limitation, social-networking system **160** may generate and send a notification including menu items liked by friends (*i.e.*, first-degree connections in social graph **200**) at a nearby location of a third-party content provider (*e.g.*, notification stating that Prince Street Cafe is nearby and that Chelsea, a friend of the user, likes their tomato soup); posts made by the third-party content provider to a corresponding page (*e.g.*, notifying the user that the credit-card reader is down); an ongoing or upcoming event hosted at a third-party content provider location (*e.g.*, notifying the user that the mayor is speaking at 8:00 pm and that 20 people are attending the event); spotlight data from reviews of a third-party content provider (*e.g.*, notification **910**). In particular embodiments, notifications may be presented at client system **130** with prompts for retrieving additional information associated with the notification. As an example and not by way of limitation, **FIG. 9A** illustrates a customized “slide” functionality, where a slide gesture may be inputted by the user of client system **130** to retrieve additional information associated with notification **910** (*e.g.*, a page corresponding to Prince Street Cafe; relevant posts by or associated with social-graph connections; and information regarding products, services, and menu items offered at the location).

[0126] In the embodiment illustrated in **FIG. 9A**, notification **910** is shown as being pushed (*i.e.*, a “push notification”) to lock screen **905** of client system **130**. Notification **910** may be presented silently on lock screen **905** or may be accompanied by audible, tactile, or other suitable feedback. Notifications may be delivered in accordance with user-specified permissions, which may provide, as an example and not by way of limitation, what types of notifications may be received (*e.g.*, notifications associated with events), from which third-party content providers notifications may be received (*e.g.*, only from businesses that the user has patronized before), when notifications may be received (*e.g.*, on weekends), how many notifications may be received (*e.g.*, no duplicates or one per week), types of content to be included in a notification (*e.g.*, only content based on first-degree social connections of the user), and how the notification may be presented on client system **130** (*e.g.*, as a silent push notification on lock screen **905**).

[0127] **FIG. 9B** illustrates an example notification **920** displayed in an interface **900** of a client system **130**. In **FIG. 9B**, notification **920** is shown as displayed in a news feed **915**, which is provided in an application running on client system **130**. Notification **920** may be selectable to reveal third-party content (*e.g.*, menu).

[0128] **FIG. 9C** illustrates an example notification **925** displayed in an interface **900** of a client system **130**. In **FIG. 9C**, notification **925** is shown as displayed in a news feed **915**, which is provided in an application running on client system **130**. Notification **925** may be sent to client system **130**, by social-networking system **160**, in response to session information, received at social-networking system **160** from beacon **310**, indicating that the a wireless communication session has been established between client system **130** and beacon **310**. Social-networking system **160** may select the particular content for inclusion in a notification based on session information of the user; for example, third-party content provided in a notification to a user whose client system **130** is not in a wireless communication session with beacon **310** (*e.g.*, notification **920**) may differ from that provided in a notification when the user’s client system **130** is in an active wireless communication session with beacon **310** (*e.g.*, notification **925**). A notification may be selectable to reveal a page corresponding to a third-party content provider, and social-networking system **160** may customize the content provided on the page based on session information of the user, as described below in connection with **FIGS. 9D** and **9E**.

[0129] FIG. 9D illustrates an example page 930 corresponding to a third-party content provider displayed in an interface 900 of a client system 130. In FIG. 9D, notification 940 is shown as displayed on page 930, which is provided in an application running on client system 130, and which corresponds to the Prince Street Cafe. In particular embodiments, social-networking system 160 may send notification 940 to client system 130 for display to the user after session information is received from beacon 310, which may be associated with Prince Street Cafe, the session information indicating that a wireless communication session has been established between client system 130 and beacon 310. In the example illustrated in FIG. 9D, notification 940 is shown as providing additional third-party content, including overview 935 introducing the Prince Street Cafe and popular menu items 940. Overview 935 and popular menu items 940 are merely illustrative, and any suitable third-party content or combination thereof may be provided to the user in notification 940. As described above in connection with FIG. 9A, the particular third-party content included in a notification may be customized to a particular user based on social-networking information and session information of the user and on social-networking information and session information of social-graph connections of the user.

[0130] FIG. 9E illustrates an example page corresponding to a third-party content provider displayed in an interface 900 of a client system 130. In FIG. 9E, notification 945 is shown as displayed on page 930, which is provided in an application running on client system 130, and which corresponds to the Prince Street Cafe. In particular embodiments, social-networking system 160 may send notification 945 to client system 130 for display to the user after session information is received from beacon 310, which may be associated with Prince Street Cafe, indicating that a wireless communication session is no longer active between client system 130 and beacon 310. In the example illustrated in FIG. 9E, notification 945 is shown as providing additional third-party content, including a departure message thanking the user for his patronage; posts 950 made recently by Prince Street Cafe; current and upcoming events 955 hosted at Prince Street Cafe; spotlight reviews 960 highlighting particular menu items reviewed, talked about, or otherwise referenced by other users; and survey 965 prompting the user to rate his experience at Prince Street Cafe as “Great,” “Okay,” or “Bad.” The particular third-party content shown as included is merely illustrative, and any suitable third-party content or combination thereof may be provided to the user in notification 945.

[0131] Although this disclosure describes and illustrates particular embodiments of FIGS. 9A–9E as being implemented by social-networking system 160, this disclosure contemplates any suitable embodiments of FIGS. 9A–9E occurring on any suitable interface and as being implemented by any suitable platform or system. As an example, and not by way of limitation, particular embodiments of FIGS. 9A–9E may be implemented by one or more beacons 310. Furthermore, although this disclosure describes and illustrates particular components, devices, or systems carrying out particular steps of the method of FIGS. 9A–9E, this disclosure contemplates any suitable combination of any suitable components, devices, or systems carrying out any suitable steps of the method of FIGS. 9A–9E.

Arrival and Departure Notifications

[0132] In particular embodiments, social-networking system 160 may send, to a first user's client system 130, a notification of a second user's arrival at or departure from a third-party content provider location. In particular embodiments, social-networking system 160 may generate notifications based on session information of the first and second users. Social-networking system 160 may receive session information associated with first and second users from one or more beacons 310 associated with and located at one or more third-party content provider locations. Social-networking system 160 may determine to send arrival and departure notifications to a first user's client system 130 based on the session information of the first user. As an example and not by way of limitation, the received session information of the first user may indicate that a wireless communication session has been established between the first user's client system 130 and beacon 310 (*i.e.*, the first user is at a first third-party content provider location), and social-networking system 160 may send, to the first user's client system 130, arrival notifications for second users arriving at the first third-party content provider location. Social-networking system 160 may receive dynamically updated session information for a second user from the same beacon 310 indicating that a wireless communication session has been established between the second user's client system 130 and beacon 310 (*i.e.*, the second user has arrived at the first third-party content provider location where the first user is also located). Social-networking system 160 may then generate and send a notification to the client system 130 of the first user based on the session information indicating that the second user has

arrived, an example of which is illustrated in **FIG. 10A**. In particular embodiments, arrival and departure notifications may be sent to a first user for second users who are connected to the first user within a threshold degree of separation in social graph **200**. As an example and not by way of limitation, the degree of separation may be one, two, three, or all, each edge between two nodes corresponding to a single degree of separation.

[0133] **FIG. 10A** illustrates an example notification **1010** displayed on a lock screen **905** of a client system **130**. In particular embodiments, social-networking system **160** may send a notification **1010** referencing a second user (*e.g.*, Mark) to interface **1000** of client system **130** of a first user based on session information of the first user and session information of the second user. As described above in connection with **FIG. 9A**, any suitable notification may be sent to client system **130** in accordance with user preferences and privacy settings. In the example illustrated in **FIG. 10A**, notification **1010** is shown as a “push notification” presented at lock screen **905** of client system **130**.

[0134] **FIG. 10B** illustrates an example notification **1020** displayed in an interface **1000** of a client system **130**. In particular embodiments, social-networking system **160** may send notification **1020** to interface **1000** of client system **130** of a first user. In **FIG. 10B**, notification **1020** is shown as displayed in a news feed **915**, which is provided in an application running on client system **130**. Notification **1020** may be sent to client system **130**, by social-networking system **160**, in response to session information, received at social-networking system **160** from beacon **310**, indicating that the a wireless communication session has been established between a client system **130** of a second user (*e.g.*, John) and beacon **310**—“John is now at Hildy’s Tavern.” As shown in **FIG. 10B**, notification **1020** may also include departure information of the second user—“He left Prince Street Cafe 20 minutes ago.” Departure information may be sent in response to receiving session information of the second user from a beacon **310** of a different third-party content provider location indicating that a wireless communication session between beacon **310** and the second user’s client system **130** lapsed or became inactive at a particular time (*e.g.*, 20 minutes ago). As shown in the example illustrated in **FIG. 10B**, arrival and departure notifications may include timing information, which may be a powerful resource for a first user trying to meet up with a second user. As an example and not by way of limitation, a first user may be late meeting up with a second user at an annual city-wide Santa pub crawl, and

may be having trouble keeping in contact with the second user, as he travels between establishments in a Santa costume similar to that worn by hundreds of others at the event. The first user may receive notification **1020** indicating that the second user (*e.g.*, John) departed from a particular third-party content provider location at a particular time and has now arrived at a new third-party content provider location (*e.g.*, Hildy's Tavern), and the first user may be able to use this information to meet up the second user at the new third-party content provider location for holiday merriment rather than following the second user around the city all day, one step behind. A user may specify in privacy settings to whom arrival and departure notifications may be sent and what information may be included in these notifications. As an example and not by way of limitation, John's privacy settings may provide permission for arrival and departure notifications to be sent to client system **130** of a particular first user (*e.g.*, a particular friend of John's) only for third-party content provider locations associated with the pub crawl event.

[0135] **FIG. 10C** illustrates an example page **1030** corresponding to a third-party content provider displayed in an interface **1000** of a client system **130**. A notification (*e.g.*, notification **1020** of **FIG. 10B**) may be selectable to reveal a page **1030** corresponding to a third-party content provider location, and social-networking system **160** may customize the content provided on the page **1030** based on session information of the user. **FIG. 10C** illustrates an example page **930** corresponding to a third-party content provider displayed in an interface **900** of a client system **130**. In **FIG. 10C**, notification **1050** (*e.g.*, Mark is here) is shown as displayed on page **1030**, which is provided in an application running on client system **130**, and which corresponds to Hildy's Tavern. As shown in the example illustrated in **FIG. 10C**, page **1030** may include tools **1040** with functionality that allows the first user to interact with the third-party content provider (*e.g.*, by "liking," checking in, looking at the menu, or messaging). In particular embodiments, arrival and departure notifications for a particular second user may be sent to the first user's client system **130** based on an invitation sent by the first user to the second user. Notification **1050** may provide a prompt by which the first user may send an invitation to a second user inviting the second user to join the first user at a first-party content provider location (*e.g.*, Hildy's Tavern), as described below in connection with **FIGS. 11A–11D**.

[0136] Although this disclosure describes and illustrates particular embodiments of **FIGS. 10A–10C** as being implemented by social-networking system **160**, this disclosure

contemplates any suitable embodiments of **FIGS. 10A–10C** occurring on any suitable interface and as being implemented by any suitable platform or system. As an example, and not by way of limitation, particular embodiments of **FIGS. 10A–10C** may be implemented by one or more beacons **310**. Furthermore, although this disclosure describes and illustrates particular components, devices, or systems carrying out particular steps of the method of **FIGS. 10A–10C**, this disclosure contemplates any suitable combination of any suitable components, devices, or systems carrying out any suitable steps of the method of **FIGS. 10A–10C**.

Invitation Notifications

[0137] In particular embodiments, social-networking system **160** may use location and session information received from one or more beacons **310** to generate and send notifications to a first user prompting the first user to invite one or more selected second users. Social-networking system **160** may receive session information associated with a first user from a beacon **310** associated with a third-party content provider and at a particular location within a place of the third-party content provider. The session information may indicate that a wireless communication session has been established between the first user's client system **130** and beacon **310** (*i.e.*, the first user is at a third-party content provider location). Social-networking system **160** may send, to the first user's client system **130**, a notification referencing one or more second users who are at locations within a threshold distance from the particular location of beacon **310** (*i.e.*, nearby second users). Social-networking system **160** may determine that one or more second users are nearby based on, for example, location information from client systems **130** associated with the one or more second users. As an example and by way of limitation, the first user may be at a bar, and the one or more second users may be in the same city or neighborhood, or otherwise within a predefined distance (*e.g.*, radius) from the beacon location within the place of the third-party content provider. Social-networking system **160** may generate and send to the first user's client system **130** a notification suggesting that the first user send a message or invitation (*e.g.*, to join the first user at the bar) to one or more of the nearby second users.

[0138] In particular embodiments, social-networking system **160** may select one or more second users of all nearby second users which may be referenced in a notification sent to the first

user's client system **130**. In particular embodiments, second users may be selected and notifications sent using techniques for determining nearby friends in U.S. Patent Application No. 14/323,915, titled "Nearby Friend Notifications on Online Social Networks," filed 03 July 2014, the entirety of which is incorporated herein by reference. In particular embodiments, social-networking system **160** may select one or more second users from the second users determined to be nearby based on session information associated with the second users indicating that the client systems of the second users are not in wireless communications sessions with beacon **310** (*e.g.*, none of the second users is already at the third-party content provider place at which the first user is located). Social-networking system **160** may select the suggested second users from among all nearby second users based on, for example, social-networking information of the first user and the suggested second users (*e.g.*, indications of affinity for a particular type of food), location information of the suggested second users (*e.g.*, more proximate second users may be more likely to accept an invitation), session information of the first user and the suggested second users (*e.g.*, client systems **130** of the first user and a particular second user have previously been in a wireless communication session at the same time with the same beacon **310**), preferences of the first or second users (*e.g.*, preferences of at least one second user indicate a preference for a type of good or service, and the third-party content provider provides the preferred type of good or service), any other suitable user information, or any combination thereof. As an example and not by way of limitation, social-networking system **160** may select a suggested second user based on session information of the second user including a history of prior wireless communication sessions established between the beacon **310** and the second client system of the second user (*e.g.*, past wireless communication sessions may indicate that the second user is more likely to return to the location). As another example, social-networking system **160** may select a suggested second user based on one or more affinities expressed by the second user. The social-networking information of the second user may include an affinity coefficient of a second node corresponding to the second user with respect to a third node in social graph **200** corresponding to the third-party content provider. As an example, the affinity coefficient may be based on one or more edges connecting the second node to the third node corresponding to the third-party content provider. **FIGS. 11A–11D**, described below, provide examples of invitation notifications.

[0139] FIG. 11A illustrates an example notification 1110 displayed on a lock screen 905 of a client system 130. In particular embodiments, social-networking system 160 may receive, from a first user's client system 130 (*e.g.*, William's client system 130, which is not shown), a request to invite at least one selected second user (*e.g.*, referenced in a notification sent to the first user's client system 130) to the place associated with a third-party content provider. Social-networking system 160 may send, in response to the request a notification 1110 to interface 1100 of client system 130 of at least one selected second user. As described above in connection with FIG. 9A, any suitable notification may be sent to client system 130 in accordance with user preferences and privacy settings. In the example illustrated in FIG. 11A, notification 1110 is shown as a "push notification" presented at lock screen 905 of client system 130.

[0140] FIG. 11B illustrates an example notification 1120 displayed in an interface 1100 of a client system 130. In FIG. 11B, notification 1120 is shown as displayed in a news feed 915, which is provided in an application running on client system 130. In particular embodiments, social-networking system 160 may send an invitation notification 1120 to at least one selected second user to join the first user (*e.g.*, William) at a place associated with a third-party content provider (*e.g.*, Prince Street Cafe). Invitation notification 1120 may include a prompt to respond to the invitation, for example, by responding "Join," "Maybe," or "Decline." Invitation notification 1120 may include any suitable third-party content associated with the place and the associated third-party content provider. As an example and not by way of limitation, invitation notification 1120 may include location information (*e.g.*, an address) of the place associated with the third-party content provider, which is shown in FIG. 11B as a map, which may be interactive and which may include customized directions from a current location of the invited second user to the third-party content provider location or any other suitable location information. Invitation notification 1120 may include a message from the first user or the third-party content provider. Invitation notification 1120 may include an identifier (*e.g.*, name and/or image) of at least one third user of the online social network, where the at least one third user's client system 130 is in an active wireless communication session with beacon 310. In the example illustrated in FIG. 11B, notification 1120 provides names and images of other users who are presently at the third-party content provider location (*e.g.*, "Andrew, Martha, and 3 others").

[0141] FIG. 11C illustrates an example notification 1130 displayed in an interface 1100 of a client system 130. In FIG. 11C, notification 1130 is shown as displayed in a news feed 915, which is provided in an application running on client system 130. Notification 1130 may be sent to a first user and may reference one or more selected second users (*e.g.*, by including selectable images respectively corresponding to the users), which may be selected by social-networking system 160, as described above, from among all nearby second users. Notification 1130 is shown as a prompt to invite one or more of the selected second users or to “choose friends” to invite to a place of a third-party content provider.

[0142] FIG. 11D illustrates an example notification 1160 and a page 1140 corresponding to a third-party content provider displayed in an interface 1100 of a client system 130. A notification (*e.g.*, notification 1130 of FIG. 11C) may be selectable to reveal page 1140 corresponding to a third-party content provider location, and social-networking system 160 may customize the content provided on the page 1140 to the particular viewing first user. As shown in the example illustrated in FIG. 11D, page 1140 may include tools 1150 with functionality that allows the first user to interact with the third-party content provider (*e.g.*, by “liking,” checking in, looking at the menu, or messaging). In FIG. 11D, notification 1160 is shown as displayed on page 1030, which is provided in an application running on client system 130, and which corresponds to Prince Street Cafe. Notification 1160 may be a prompt to invite other users and may reference one or more users presently at the third-party content provider place (*e.g.*, text stating that “William, Andrew, Martha, and 3 friends are here” and corresponding images depicting the users). Notification 1160 may also include any other suitable functionality for interacting with the notification, including, for example, tools for messaging a particular user, locating a particular user, creating a “moment” or post based on notification 1160, any other suitable interaction tools, or any combination thereof.

[0143] Social-networking system 160 may provide arrival and departure notifications when a second user arrives at or departs from third-party content provider locations after having accepted an invitation from the first user, as described above in connection with FIGS. 10A–10C. Similarly, social-networking system 160 may send arrival and departure notifications associated with a first user to an invited second user so that the invited second user may have an

easier time meeting up with the first user, in particular if the first user is moving to different locations.

[0144] Although this disclosure describes and illustrates particular embodiments of **FIGS. 11A–11D** as being implemented by social-networking system **160**, this disclosure contemplates any suitable embodiments of **FIGS. 11A–11D** occurring on any suitable interface and as being implemented by any suitable platform or system. As an example, and not by way of limitation, particular embodiments of **FIGS. 11A–11D** may be implemented by one or more beacons **310**. Furthermore, although this disclosure describes and illustrates particular components, devices, or systems carrying out particular steps of the method of **FIGS. 11A–11D**, this disclosure contemplates any suitable combination of any suitable components, devices, or systems carrying out any suitable steps of the method of **FIGS. 11A–11D**.

[0145] **FIG. 12** illustrates an example self-portrait interface **1200** displayed on a client system **130**. In particular embodiments, once a wireless communication session has been established between client system **130** and beacon **310** of a third-party content provider, third-party system **170**, social-networking system **160**, or beacon **310** may send a request for additional information to client system **130** of a user. A response may be inputted by the user or otherwise inputted at client system **130** and sent by client system **130**, directly or via beacon **310**, to the questioning third-party system **170**, social-networking system **160**, or beacon **310**. In the embodiment illustrated in **FIG. 12**, social-networking system **160** may provide a self-portrait interface **1200** and prompt the user to take and send a self-portrait **1210** (*i.e.*, a “selfie”) showing the user at the third-party content provider place, as shown below in **FIG. 12**. In particular embodiments, client system **130** may automatically activate the front-facing camera mode when self-portrait interface **1200** is provided. As shown in **FIG. 12**, the user may set permissions as to who may access self-portrait **1210** (*e.g.*, “Only you and the business will be able to see this.”) and may decline to take self-portrait **1210**, send self-portrait **1210**, or both.

[0146] Although this disclosure describes and illustrates particular embodiments of **FIG. 12** as being implemented by social-networking system **160**, this disclosure contemplates any suitable embodiments of **FIG. 12** occurring on any suitable interface and as being implemented by any suitable platform or system. As an example, and not by way of limitation, particular embodiments of **FIG. 12** may be implemented by one or more beacons **310**. Furthermore,

although this disclosure describes and illustrates particular components, devices, or systems carrying out particular steps of the method of **FIG. 12**, this disclosure contemplates any suitable combination of any suitable components, devices, or systems carrying out any suitable steps of the method of **FIG. 12**.

[0147] **FIG. 13** illustrates an example beacon **310** in a real-world environment **1300**. In the embodiment illustrated in **FIG. 13**, beacon **310** is shown as a three-dimensional object having a multi-faceted casing (inside of which hardware components may be housed), a substantially flat top, and a substantially flat bottom. Although depicted in a particular way in **FIG. 13**, beacon **310** may have any suitable shape, form, or design, may be constructed of any suitable materials or combinations of materials, and may be free-standing, removably affixed to any suitable surface, or permanently affixed to any suitable surface. As an example and not by way of limitation, beacon **310** is depicted in **FIG. 13** as being affixed to a wooden surface (*e.g.*, via a double-sided adhesive) in real-world environment **1300**. Particular embodiments of this disclosure are described as being implemented by or based on information received from a beacon **310** by way of illustration and not by way of limitation. This disclosure contemplates any other suitable geographic-positioning-capable device or system being used instead of or in addition to one or more beacons **310**. As an example and not by way of limitation, beacon-type functionality may be incorporated into a smartphone of a third-party content provider.

[0148] Although this disclosure describes and illustrates particular embodiments of **FIG. 13** as being implemented by beacon **310**, this disclosure contemplates any suitable embodiments of **FIG. 13** occurring on any suitable interface and as being implemented by any suitable platform or system. As an example, and not by way of limitation, particular embodiments of **FIG. 13** may be implemented by any suitable geographic-positioning-capable device or system. Furthermore, although this disclosure describes and illustrates particular components, devices, or systems carrying out particular steps of the method of **FIG. 13**, this disclosure contemplates any suitable combination of any suitable components, devices, or systems carrying out any suitable steps of the method of **FIG. 13**.

[0149] **FIG. 14** illustrates an example method **1400** for sending a notification to client system **130**. The method may begin at step **1410**, where social-networking system **160** may access social graph **200** comprising a plurality of nodes and a plurality of edges connecting the

nodes, each of the edges between two of the nodes representing a single degree of separation between them, the nodes comprising: a first node corresponding to a first user of the online social network, and a plurality of second nodes respectively corresponding to a plurality of second users associated with the online social network, each second node being connected to the first node in social graph **200** by a threshold degree of separation. At step **1420**, social-networking system **160** may receive, from beacon **310** associated with third-party content provider, session information of the first user, wherein: beacon **310** is associated with a particular location within a place associated with the third-party content provider, and the session information of the first user indicates that a first client system **130** of the first user is within wireless range of and proximate to beacon **310**, a wireless communication session being active between beacon **310** and the first client system **130**. At step **1430**, social-networking system **160** may select one or more of the second users, wherein each of the second users is selected based on a second location of a second client system **130** associated with the second user, the second location being within a threshold distance of the particular location of the beacon **310**, and wherein a wireless communication session is not active between the beacon **310** and each of second client systems **130** associated with the selected second users. At step **1440**, social-networking system **160** may send, to the first client system **130** of the first user, a notification referencing one or more of the selected second users. Particular embodiments may repeat one or more steps of the method of **FIG. 14**, where appropriate. Although this disclosure describes and illustrates particular steps of the method of **FIG. 14** as occurring in a particular order, this disclosure contemplates any suitable steps of the method of **FIG. 14** occurring in any suitable order. Moreover, although this disclosure describes and illustrates an example method for sending a notification to client system **130**, including the particular steps of the method of **FIG. 14**, this disclosure contemplates any suitable method for sending a notification to client system **130** including any suitable steps, which may include all, some, or none of the steps of the method of **FIG. 14**, where appropriate. Furthermore, although this disclosure describes and illustrates particular components, devices, or systems carrying out particular steps of the method of **FIG. 14**, this disclosure contemplates any suitable combination of any suitable components, devices, or systems carrying out any suitable steps of the method of **FIG. 14**.

Social Graph Affinity and Coefficient

[0150] In particular embodiments, social-networking system **160** may determine the social-graph affinity (which may be referred to herein as “affinity”) of various social-graph entities for each other. Affinity may represent the strength of a relationship or level of interest between particular objects associated with the online social network, such as users, concepts, content, actions, advertisements, other objects associated with the online social network, or any suitable combination thereof. Affinity may also be determined with respect to objects associated with third-party systems **170** or other suitable systems. An overall affinity for a social-graph entity for each user, subject matter, or type of content may be established. The overall affinity may change based on continued monitoring of the actions or relationships associated with the social-graph entity. Although this disclosure describes determining particular affinities in a particular manner, this disclosure contemplates determining any suitable affinities in any suitable manner.

[0151] In particular embodiments, social-networking system **160** may measure or quantify social-graph affinity using an affinity coefficient (which may be referred to herein as “coefficient”). The coefficient may represent or quantify the strength of a relationship between particular objects associated with the online social network. The coefficient may also represent a probability or function that measures a predicted probability that a user will perform a particular action based on the user’s interest in the action. In this way, a user’s future actions may be predicted based on the user’s prior actions, where the coefficient may be calculated at least in part a the history of the user’s actions. Coefficients may be used to predict any number of actions, which may be within or outside of the online social network. As an example and not by way of limitation, these actions may include various types of communications, such as sending messages, posting content, or commenting on content; various types of observation actions, such as accessing or viewing profile pages, media, or other suitable content; various types of coincidence information about two or more social-graph entities, such as being in the same group, tagged in the same photograph, checked-in at the same location, or attending the same event; or other suitable actions. Although this disclosure describes measuring affinity in a particular manner, this disclosure contemplates measuring affinity in any suitable manner.

[0152] In particular embodiments, social-networking system **160** may use a variety of factors to calculate a coefficient. These factors may include, for example, user actions, types of relationships between objects, location information, other suitable factors, or any combination thereof. In particular embodiments, different factors may be weighted differently when calculating the coefficient. The weights for each factor may be static or the weights may change according to, for example, the user, the type of relationship, the type of action, the user's location, and so forth. Ratings for the factors may be combined according to their weights to determine an overall coefficient for the user. As an example and not by way of limitation, particular user actions may be assigned both a rating and a weight while a relationship associated with the particular user action is assigned a rating and a correlating weight (*e.g.*, so the weights total **100%**). To calculate the coefficient of a user towards a particular object, the rating assigned to the user's actions may comprise, for example, 60% of the overall coefficient, while the relationship between the user and the object may comprise 40% of the overall coefficient. In particular embodiments, the social-networking system **160** may consider a variety of variables when determining weights for various factors used to calculate a coefficient, such as, for example, the time since information was accessed, decay factors, frequency of access, relationship to information or relationship to the object about which information was accessed, relationship to social-graph entities connected to the object, short- or long-term averages of user actions, user feedback, other suitable variables, or any combination thereof. As an example and not by way of limitation, a coefficient may include a decay factor that causes the strength of the signal provided by particular actions to decay with time, such that more recent actions are more relevant when calculating the coefficient. The ratings and weights may be continuously updated based on continued tracking of the actions upon which the coefficient is based. Any type of process or algorithm may be employed for assigning, combining, averaging, and so forth the ratings for each factor and the weights assigned to the factors. In particular embodiments, social-networking system **160** may determine coefficients using machine-learning algorithms trained on historical actions and past user responses, or data farmed from users by exposing them to various options and measuring responses. Although this disclosure describes calculating coefficients in a particular manner, this disclosure contemplates calculating coefficients in any suitable manner.

[0153] In particular embodiments, social-networking system **160** may calculate a coefficient based on a user's actions. Social-networking system **160** may monitor such actions on the online social network, on a third-party system **170**, on other suitable systems, or any combination thereof. Any suitable type of user actions may be tracked or monitored. Typical user actions include viewing profile pages, creating or posting content, interacting with content, tagging or being tagged in images, joining groups, listing and confirming attendance at events, checking-in at locations, liking particular pages, creating pages, and performing other tasks that facilitate social action. In particular embodiments, social-networking system **160** may calculate a coefficient based on the user's actions with particular types of content. The content may be associated with the online social network, a third-party system **170**, or another suitable system. The content may include users, profile pages, posts, news stories, headlines, instant messages, chat room conversations, emails, advertisements, pictures, video, music, other suitable objects, or any combination thereof. Social-networking system **160** may analyze a user's actions to determine whether one or more of the actions indicate an affinity for subject matter, content, other users, and so forth. As an example and not by way of limitation, if a user may make frequently posts content related to "coffee" or variants thereof, social-networking system **160** may determine the user has a high coefficient with respect to the concept "coffee." Particular actions or types of actions may be assigned a higher weight and/or rating than other actions, which may affect the overall calculated coefficient. As an example and not by way of limitation, if a first user emails a second user, the weight or the rating for the action may be higher than if the first user simply views the user-profile page for the second user.

[0154] In particular embodiments, social-networking system **160** may calculate a coefficient based on the type of relationship between particular objects. Referencing the social graph **200**, social-networking system **160** may analyze the number and/or type of edges **206** connecting particular user nodes **202** and concept nodes **204** when calculating a coefficient. As an example and not by way of limitation, user nodes **202** that are connected by a spouse-type edge (representing that the two users are married) may be assigned a higher coefficient than a user nodes **202** that are connected by a friend-type edge. In other words, depending upon the weights assigned to the actions and relationships for the particular user, the overall affinity may be determined to be higher for content about the user's spouse than for content about the user's

friend. In particular embodiments, the relationships a user has with another object may affect the weights and/or the ratings of the user's actions with respect to calculating the coefficient for that object. As an example and not by way of limitation, if a user is tagged in first photo, but merely likes a second photo, social-networking system **160** may determine that the user has a higher coefficient with respect to the first photo than the second photo because having a tagged-in-type relationship with content may be assigned a higher weight and/or rating than having a like-type relationship with content. In particular embodiments, social-networking system **160** may calculate a coefficient for a first user based on the relationship one or more second users have with a particular object. In other words, the connections and coefficients other users have with an object may affect the first user's coefficient for the object. As an example and not by way of limitation, if a first user is connected to or has a high coefficient for one or more second users, and those second users are connected to or have a high coefficient for a particular object, social-networking system **160** may determine that the first user should also have a relatively high coefficient for the particular object. In particular embodiments, the coefficient may be based on the degree of separation between particular objects. The lower coefficient may represent the decreasing likelihood that the first user will share an interest in content objects of the user that is indirectly connected to the first user in the social graph **200**. As an example and not by way of limitation, social-graph entities that are closer in the social graph **200** (*i.e.*, fewer degrees of separation) may have a higher coefficient than entities that are further apart in the social graph **200**.

[0155] In particular embodiments, social-networking system **160** may calculate a coefficient based on location information. Objects that are geographically closer to each other may be considered to be more related or of more interest to each other than more distant objects. In particular embodiments, the coefficient of a user towards a particular object may be based on the proximity of the object's location to a current location associated with the user (or the location of a client system **130** of the user). A first user may be more interested in other users or concepts that are closer to the first user. As an example and not by way of limitation, if a user is one mile from an airport and two miles from a gas station, social-networking system **160** may determine that the user has a higher coefficient for the airport than the gas station based on the proximity of the airport to the user.

[0156] In particular embodiments, social-networking system **160** may perform particular actions with respect to a user based on coefficient information. Coefficients may be used to predict whether a user will perform a particular action based on the user's interest in the action. A coefficient may be used when generating or presenting any type of objects to a user, such as advertisements, search results, news stories, media, messages, notifications, or other suitable objects. The coefficient may also be utilized to rank and order such objects, as appropriate. In this way, social-networking system **160** may provide information that is relevant to user's interests and current circumstances, increasing the likelihood that they will find such information of interest. In particular embodiments, social-networking system **160** may generate content based on coefficient information. Content objects may be provided or selected based on coefficients specific to a user. As an example and not by way of limitation, the coefficient may be used to generate media for the user, where the user may be presented with media for which the user has a high overall coefficient with respect to the media object. As another example and not by way of limitation, the coefficient may be used to generate advertisements for the user, where the user may be presented with advertisements for which the user has a high overall coefficient with respect to the advertised object. In particular embodiments, social-networking system **160** may generate search results based on coefficient information. Search results for a particular user may be scored or ranked based on the coefficient associated with the search results with respect to the first querying user. As an example and not by way of limitation, search results corresponding to objects with higher coefficients may be ranked higher on a search-results page than results corresponding to objects having lower coefficients.

[0157] In particular embodiments, social-networking system **160** may calculate a coefficient in response to a request for a coefficient from a particular system or process. To predict the likely actions a user may take (or may be the subject of) in a given situation, any process may request a calculated coefficient for a user. The request may also include a set of weights to use for various factors used to calculate the coefficient. This request may come from a process running on the online social network, from a third-party system **170** (e.g., via an API or other communication channel), or from another suitable system. In response to the request, social-networking system **160** may calculate the coefficient (or access the coefficient information if it has previously been calculated and stored). In particular embodiments, social-networking

system **160** may measure an affinity with respect to a particular process. Different processes (both internal and external to the online social network) may request a coefficient for a particular object or set of objects. Social-networking system **160** may provide a measure of affinity that is relevant to the particular process that requested the measure of affinity. In this way, each process receives a measure of affinity that is tailored for the different context in which the process will use the measure of affinity.

[0158] In connection with social-graph affinity and affinity coefficients, particular embodiments may utilize one or more systems, components, elements, functions, methods, operations, or steps disclosed in U.S. Patent Application No. 11/503093, filed 11 August 2006, U.S. Patent Application No. 12/977027, filed 22 December 2010, U.S. Patent Application No. 12/978265, filed 23 December 2010, and U.S. Patent Application No. 13/632869, filed 01 October 2012, each of which is incorporated by reference.

Advertising

[0159] In particular embodiments, an advertisement may be text (which may be HTML-linked), one or more images (which may be HTML-linked), one or more videos, audio, one or more ADOBE FLASH files, a suitable combination of these, or any other suitable advertisement in any suitable digital format presented on one or more webpages, in one or more e-mails, or in connection with search results requested by a user. In addition or as an alternative, an advertisement may be one or more sponsored stories (*e.g.*, a news-feed or ticker item on social-networking system **160**). A sponsored story may be a social action by a user (such as “liking” a page, “liking” or commenting on a post on a page, RSVPing to an event associated with a page, voting on a question posted on a page, checking in to a place, using an application or playing a game, or “liking” or sharing a website) that an advertiser promotes, for example, by having the social action presented within a pre-determined area of a profile page of a user or other page, presented with additional information associated with the advertiser, bumped up or otherwise highlighted within news feeds or tickers of other users, or otherwise promoted. The advertiser may pay to have the social action promoted. As an example and not by way of limitation, advertisements may be included among the search results of a search-results page, where sponsored content is promoted over non-sponsored content.

[0160] In particular embodiments, an advertisement may be requested for display within social-networking-system webpages, third-party webpages, or other pages. An advertisement may be displayed in a dedicated portion of a page, such as in a banner area at the top of the page, in a column at the side of the page, in a GUI of the page, in a pop-up window, in a drop-down menu, in an input field of the page, over the top of content of the page, or elsewhere with respect to the page. In addition or as an alternative, an advertisement may be displayed within an application. An advertisement may be displayed within dedicated pages, requiring the user to interact with or watch the advertisement before the user may access a page or utilize an application. The user may, for example view the advertisement through a web browser.

[0161] A user may interact with an advertisement in any suitable manner. The user may click or otherwise select the advertisement. By selecting the advertisement, the user may be directed to (or a browser or other application being used by the user) a page associated with the advertisement. At the page associated with the advertisement, the user may take additional actions, such as purchasing a product or service associated with the advertisement, receiving information associated with the advertisement, or subscribing to a newsletter associated with the advertisement. An advertisement with audio or video may be played by selecting a component of the advertisement (like a “play button”). Alternatively, by selecting the advertisement, social-networking system **160** may execute or modify a particular action of the user.

[0162] An advertisement may also include social-networking-system functionality that a user may interact with. As an example and not by way of limitation, an advertisement may enable a user to “like” or otherwise endorse the advertisement by selecting an icon or link associated with endorsement. As another example and not by way of limitation, an advertisement may enable a user to search (*e.g.*, by executing a query) for content related to the advertiser. Similarly, a user may share the advertisement with another user (*e.g.*, through social-networking system **160**) or RSVP (*e.g.*, through social-networking system **160**) to an event associated with the advertisement. In addition or as an alternative, an advertisement may include social-networking-system context directed to the user. As an example and not by way of limitation, an advertisement may display information about a friend of the user within social-networking system **160** who has taken an action associated with the subject matter of the advertisement.

Privacy

[0163] In particular embodiments, one or more of the content objects of the online social network may be associated with a privacy setting. The privacy settings (or “access settings”) for an object may be stored in any suitable manner, such as, for example, in association with the object, in an index on an authorization server, in another suitable manner, or any combination thereof. A privacy setting of an object may specify how the object (or particular information associated with an object) can be accessed (*e.g.*, viewed or shared) using the online social network. Where the privacy settings for an object allow a particular user to access that object, the object may be described as being “visible” with respect to that user. As an example and not by way of limitation, a user of the online social network may specify privacy settings for a user-profile page identify a set of users that may access the work experience information on the user-profile page, thus excluding other users from accessing the information. In particular embodiments, the privacy settings may specify a “blocked list” of users that should not be allowed to access certain information associated with the object. In other words, the blocked list may specify one or more users or entities for which an object is not visible. As an example and not by way of limitation, a user may specify a set of users that may not access photos albums associated with the user, thus excluding those users from accessing the photo albums (while also possibly allowing certain users not within the set of users to access the photo albums). In particular embodiments, privacy settings may be associated with particular social-graph elements. Privacy settings of a social-graph element, such as a node or an edge, may specify how the social-graph element, information associated with the social-graph element, or content objects associated with the social-graph element can be accessed using the online social network. As an example and not by way of limitation, a particular concept node 204 corresponding to a particular photo may have a privacy setting specifying that the photo may only be accessed by users tagged in the photo and their friends. In particular embodiments, privacy settings may allow users to opt in or opt out of having their actions logged by social-networking system **160** or shared with other systems (*e.g.*, third-party system **170**). In particular embodiments, the privacy settings associated with an object may specify any suitable granularity of permitted access or denial of access. As an example and not by way of limitation, access or denial of access

may be specified for particular users (*e.g.*, only me, my roommates, and my boss), users within a particular degrees-of-separation (*e.g.*, friends, or friends-of-friends), user groups (*e.g.*, the gaming club, my family), user networks (*e.g.*, employees of particular employers, students or alumni of particular university), all users (“public”), no users (“private”), users of third-party systems **170**, particular applications (*e.g.*, third-party applications, external websites), other suitable users or entities, or any combination thereof. Although this disclosure describes using particular privacy settings in a particular manner, this disclosure contemplates using any suitable privacy settings in any suitable manner.

[0164] In particular embodiments, one or more servers **162** may be authorization/privacy servers for enforcing privacy settings. In response to a request from a user (or other entity) for a particular object stored in a data store **164**, social-networking system **160** may send a request to the data store **164** for the object. The request may identify the user associated with the request and may only be sent to the user (or a client system **130** of the user) if the authorization server determines that the user is authorized to access the object based on the privacy settings associated with the object. If the requesting user is not authorized to access the object, the authorization server may prevent the requested object from being retrieved from the data store **164**, or may prevent the requested object from be sent to the user. In the search query context, an object may only be generated as a search result if the querying user is authorized to access the object. In other words, the object must have a visibility that is visible to the querying user. If the object has a visibility that is not visible to the user, the object may be excluded from the search results. Although this disclosure describes enforcing privacy settings in a particular manner, this disclosure contemplates enforcing privacy settings in any suitable manner.

Systems and Methods

[0165] **FIG. 15** illustrates an example computer system **1500**. In particular embodiments, one or more computer systems **1500** perform one or more steps of one or more methods described or illustrated herein. In particular embodiments, one or more computer systems **1500** provide functionality described or illustrated herein. In particular embodiments, software running on one or more computer systems **1500** performs one or more steps of one or more methods described or illustrated herein or provides functionality described or illustrated herein. Particular

embodiments include one or more portions of one or more computer systems **1500**. Herein, reference to a computer system may encompass a computing device, and vice versa, where appropriate. Moreover, reference to a computer system may encompass one or more computer systems, where appropriate.

[0166] This disclosure contemplates any suitable number of computer systems **1500**. This disclosure contemplates computer system **1500** taking any suitable physical form. As example and not by way of limitation, computer system **1500** may be an embedded computer system, a system-on-chip (SOC), a single-board computer system (SBC) (such as, for example, a computer-on-module (COM) or system-on-module (SOM)), a desktop computer system, a laptop or notebook computer system, an interactive kiosk, a mainframe, a mesh of computer systems, a mobile telephone, a personal digital assistant (PDA), a server, a tablet computer system, or a combination of two or more of these. Where appropriate, computer system **1500** may include one or more computer systems **1500**; be unitary or distributed; span multiple locations; span multiple machines; span multiple data centers; or reside in a cloud, which may include one or more cloud components in one or more networks. Where appropriate, one or more computer systems **1500** may perform without substantial spatial or temporal limitation one or more steps of one or more methods described or illustrated herein. As an example and not by way of limitation, one or more computer systems **1500** may perform in real time or in batch mode one or more steps of one or more methods described or illustrated herein. One or more computer systems **1500** may perform at different times or at different locations one or more steps of one or more methods described or illustrated herein, where appropriate.

[0167] In particular embodiments, computer system **1500** includes a processor **1502**, memory **1504**, storage **1506**, an input/output (I/O) interface **1508**, a communication interface **1510**, and a bus **1512**. Although this disclosure describes and illustrates a particular computer system having a particular number of particular components in a particular arrangement, this disclosure contemplates any suitable computer system having any suitable number of any suitable components in any suitable arrangement.

[0168] In particular embodiments, processor **1502** includes hardware for executing instructions, such as those making up a computer program. As an example and not by way of limitation, to execute instructions, processor **1502** may retrieve (or fetch) the instructions from

an internal register, an internal cache, memory **1504**, or storage **1506**; decode and execute them; and then write one or more results to an internal register, an internal cache, memory **1504**, or storage **1506**. In particular embodiments, processor **1502** may include one or more internal caches for data, instructions, or addresses. This disclosure contemplates processor **1502** including any suitable number of any suitable internal caches, where appropriate. As an example and not by way of limitation, processor **1502** may include one or more instruction caches, one or more data caches, and one or more translation lookaside buffers (TLBs). Instructions in the instruction caches may be copies of instructions in memory **1504** or storage **1506**, and the instruction caches may speed up retrieval of those instructions by processor **1502**. Data in the data caches may be copies of data in memory **1504** or storage **1506** for instructions executing at processor **1502** to operate on; the results of previous instructions executed at processor **1502** for access by subsequent instructions executing at processor **1502** or for writing to memory **1504** or storage **1506**; or other suitable data. The data caches may speed up read or write operations by processor **1502**. The TLBs may speed up virtual-address translation for processor **1502**. In particular embodiments, processor **1502** may include one or more internal registers for data, instructions, or addresses. This disclosure contemplates processor **1502** including any suitable number of any suitable internal registers, where appropriate. Where appropriate, processor **1502** may include one or more arithmetic logic units (ALUs); be a multi-core processor; or include one or more processors **1502**. Although this disclosure describes and illustrates a particular processor, this disclosure contemplates any suitable processor.

[0169] In particular embodiments, memory **1504** includes main memory for storing instructions for processor **1502** to execute or data for processor **1502** to operate on. As an example and not by way of limitation, computer system **1500** may load instructions from storage **1506** or another source (such as, for example, another computer system **1500**) to memory **1504**. Processor **1502** may then load the instructions from memory **1504** to an internal register or internal cache. To execute the instructions, processor **1502** may retrieve the instructions from the internal register or internal cache and decode them. During or after execution of the instructions, processor **1502** may write one or more results (which may be intermediate or final results) to the internal register or internal cache. Processor **1502** may then write one or more of those results to memory **1504**. In particular embodiments, processor **1502** executes only instructions in one or

more internal registers or internal caches or in memory **1504** (as opposed to storage **1506** or elsewhere) and operates only on data in one or more internal registers or internal caches or in memory **1504** (as opposed to storage **1506** or elsewhere). One or more memory buses (which may each include an address bus and a data bus) may couple processor **1502** to memory **1504**. Bus **1512** may include one or more memory buses, as described below. In particular embodiments, one or more memory management units (MMUs) reside between processor **1502** and memory **1504** and facilitate accesses to memory **1504** requested by processor **1502**. In particular embodiments, memory **1504** includes random access memory (RAM). This RAM may be volatile memory, where appropriate. Where appropriate, this RAM may be dynamic RAM (DRAM) or static RAM (SRAM). Moreover, where appropriate, this RAM may be single-ported or multi-ported RAM. This disclosure contemplates any suitable RAM. Memory **1504** may include one or more memories **1504**, where appropriate. Although this disclosure describes and illustrates particular memory, this disclosure contemplates any suitable memory.

[0170] In particular embodiments, storage **1506** includes mass storage for data or instructions. As an example and not by way of limitation, storage **1506** may include a hard disk drive (HDD), a floppy disk drive, flash memory, an optical disc, a magneto-optical disc, magnetic tape, or a Universal Serial Bus (USB) drive or a combination of two or more of these. Storage **1506** may include removable or non-removable (or fixed) media, where appropriate. Storage **1506** may be internal or external to computer system **1500**, where appropriate. In particular embodiments, storage **1506** is non-volatile, solid-state memory. In particular embodiments, storage **1506** includes read-only memory (ROM). Where appropriate, this ROM may be mask-programmed ROM, programmable ROM (PROM), erasable PROM (EPROM), electrically erasable PROM (EEPROM), electrically alterable ROM (EAROM), or flash memory or a combination of two or more of these. This disclosure contemplates mass storage **1506** taking any suitable physical form. Storage **1506** may include one or more storage control units facilitating communication between processor **1502** and storage **1506**, where appropriate. Where appropriate, storage **1506** may include one or more storages **1506**. Although this disclosure describes and illustrates particular storage, this disclosure contemplates any suitable storage.

[0171] In particular embodiments, I/O interface **1508** includes hardware, software, or both, providing one or more interfaces for communication between computer system **1500** and

one or more I/O devices. Computer system **1500** may include one or more of these I/O devices, where appropriate. One or more of these I/O devices may enable communication between a person and computer system **1500**. As an example and not by way of limitation, an I/O device may include a keyboard, keypad, microphone, monitor, mouse, printer, scanner, speaker, still camera, stylus, tablet, touch screen, trackball, video camera, another suitable I/O device or a combination of two or more of these. An I/O device may include one or more sensors. This disclosure contemplates any suitable I/O devices and any suitable I/O interfaces **1508** for them. Where appropriate, I/O interface **1508** may include one or more device or software drivers enabling processor **1502** to drive one or more of these I/O devices. I/O interface **1508** may include one or more I/O interfaces **1508**, where appropriate. Although this disclosure describes and illustrates a particular I/O interface, this disclosure contemplates any suitable I/O interface.

[0172] In particular embodiments, communication interface **1510** includes hardware, software, or both providing one or more interfaces for communication (such as, for example, packet-based communication) between computer system **1500** and one or more other computer systems **1500** or one or more networks. As an example and not by way of limitation, communication interface **1510** may include a network interface controller (NIC) or network adapter for communicating with an Ethernet or other wire-based network or a wireless NIC (WNIC) or wireless adapter for communicating with a wireless network, such as a WI-FI network. This disclosure contemplates any suitable network and any suitable communication interface **1510** for it. As an example and not by way of limitation, computer system **1500** may communicate with an ad hoc network, a personal area network (PAN), a local area network (LAN), a wide area network (WAN), a metropolitan area network (MAN), or one or more portions of the Internet or a combination of two or more of these. One or more portions of one or more of these networks may be wired or wireless. As an example, computer system **1500** may communicate with a wireless PAN (WPAN) (such as, for example, a BLUETOOTH WPAN), a WI-FI network, a WI-MAX network, a cellular telephone network (such as, for example, a Global System for Mobile Communications (GSM) network), or other suitable wireless network or a combination of two or more of these. Computer system **1500** may include any suitable communication interface **1510** for any of these networks, where appropriate. Communication interface **1510** may include one or more communication interfaces **1510**, where appropriate.

Although this disclosure describes and illustrates a particular communication interface, this disclosure contemplates any suitable communication interface.

[0173] In particular embodiments, bus **1512** includes hardware, software, or both coupling components of computer system **1500** to each other. As an example and not by way of limitation, bus **1512** may include an Accelerated Graphics Port (AGP) or other graphics bus, an Enhanced Industry Standard Architecture (EISA) bus, a front-side bus (FSB), a HYPERTRANSPORT (HT) interconnect, an Industry Standard Architecture (ISA) bus, an INFINIBAND interconnect, a low-pin-count (LPC) bus, a memory bus, a Micro Channel Architecture (MCA) bus, a Peripheral Component Interconnect (PCI) bus, a PCI-Express (PCIe) bus, a serial advanced technology attachment (SATA) bus, a Video Electronics Standards Association local (VLB) bus, or another suitable bus or a combination of two or more of these. Bus **1512** may include one or more buses **1512**, where appropriate. Although this disclosure describes and illustrates a particular bus, this disclosure contemplates any suitable bus or interconnect.

[0174] Herein, a computer-readable non-transitory storage medium or media may include one or more semiconductor-based or other integrated circuits (ICs) (such, as for example, field-programmable gate arrays (FPGAs) or application-specific ICs (ASICs)), hard disk drives (HDDs), hybrid hard drives (HHDs), optical discs, optical disc drives (ODDs), magneto-optical discs, magneto-optical drives, floppy diskettes, floppy disk drives (FDDs), magnetic tapes, solid-state drives (SSDs), RAM-drives, SECURE DIGITAL cards or drives, any other suitable computer-readable non-transitory storage media, or any suitable combination of two or more of these, where appropriate. A computer-readable non-transitory storage medium may be volatile, non-volatile, or a combination of volatile and non-volatile, where appropriate.

Miscellaneous

[0175] Herein, “or” is inclusive and not exclusive, unless expressly indicated otherwise or indicated otherwise by context. Therefore, herein, “A or B” means “A, B, or both,” unless expressly indicated otherwise or indicated otherwise by context. Moreover, “and” is both joint and several, unless expressly indicated otherwise or indicated otherwise by context. Therefore,

herein, “A and B” means “A and B, jointly or severally,” unless expressly indicated otherwise or indicated otherwise by context.

[0176] The scope of this disclosure encompasses all changes, substitutions, variations, alterations, and modifications to the example embodiments described or illustrated herein that a person having ordinary skill in the art would comprehend. The scope of this disclosure is not limited to the example embodiments described or illustrated herein. Moreover, although this disclosure describes and illustrates respective embodiments herein as including particular components, elements, feature, functions, operations, or steps, any of these embodiments may include any combination or permutation of any of the components, elements, features, functions, operations, or steps described or illustrated anywhere herein that a person having ordinary skill in the art would comprehend. Furthermore, reference in the appended claims to an apparatus or system or a component of an apparatus or system being adapted to, arranged to, capable of, configured to, enabled to, operable to, or operative to perform a particular function encompasses that apparatus, system, component, whether or not it or that particular function is activated, turned on, or unlocked, as long as that apparatus, system, or component is so adapted, arranged, capable, configured, enabled, operable, or operative.

CLAIMS:

What is claimed is:

1. A method comprising, by one or more computing devices of an online social network:
 - accessing a social graph comprising a plurality of nodes and a plurality of edges connecting the nodes, each of the edges between two of the nodes representing a single degree of separation between them, the nodes comprising:
 - a first node corresponding to a first user of the online social network, and
 - a plurality of second nodes respectively corresponding to a plurality of second users associated with the online social network, each second node being connected to the first node in the social graph by a threshold degree of separation;
 - receiving, from a beacon associated with a third-party content provider, session information of the first user, wherein:
 - the beacon is associated with a particular location within a place associated with the third-party content provider, and
 - the session information of the first user indicates that a first client system of the first user is within wireless range of and proximate to the beacon, a wireless communication session being active between the beacon and the first client system;
 - selecting one or more of the second users, wherein the selecting is based on a second location of a second client system associated with the second user, the second location being within a threshold distance of the particular location of the beacon, and wherein a wireless communication session is not active between the beacon and each of second client systems associated with the selected second users; and
 - sending, to the first client system of the first user, a notification referencing one or more of the selected second users.
2. The method of Claim 1, wherein the threshold degree of separation is one, two, three, or all.

3. The method of Claim 1 or 2, further comprising:

receiving, from the first client system, a request to invite at least one of the selected second users referenced in the notification to the place associated with the third-party content provider; and

sending, in response to the request, a message to the second client system of the at least one selected second user.

4. The method of Claim 3, further comprising:

sending, to the first client system, updated location information for the at least one selected second user when a wireless communication system is established between the second client system of the at least one second user and the beacon.

5. The method of Claim 3, wherein the message comprises:

an invitation to join the first user at the place associated with the third-party content provider; and

a prompt to respond to the invitation;

preferably wherein the message further comprises location information of the place associated with the third-party content provider.

6. The method of Claim 5, wherein the message further comprises an identifier of at least one third user of an online social network, the at least one third user being associated with a respective third client system, wherein a wireless communication session is active between the beacon and the third client system.

7. The method of any of Claims 1 to 6, further comprising receiving, from the beacon, session information for at least one second user;

preferably wherein the selecting of one or more second users is further based on the received session information of the at least one second user.

8. The method of Claim, 7 wherein the session information of the at least one second user comprises a history of one or more prior wireless communication sessions established between the beacon and the second client system of the at least one second user.

9. The method of any of Claims 1 to 8, wherein the selecting of one or more second users is further based on user preferences of at least one second user.

10. The method of Claim 9, wherein the user preferences of the at least one second user indicate a preference for a type of good or service, and wherein the third-party content provider comprises the preferred type of good or service.

11. The method of any of Claims 1 to 10, wherein the selecting of one or more second users is further based on an affinity coefficient of at least one second node with respect to a third node in the social graph, the third node corresponding to the third-party content provider.

12. The method of Claim 11, wherein the affinity coefficient is based on one or more edges connecting the at least one second node to the third node.

13. One or more computer-readable non-transitory storage media embodying software that is operable when executed to perform a method according to any of Claims 1 to 12.

14. A system comprising: one or more processors; and at least one memory coupled to the processors and comprising instructions executable by the processors, the processors operable when executing the instructions to perform a method according to any of the Claims 1 to 12.

15. A computer program product, preferably comprising a computer-readable non-transitory storage media, that is operable when executed on a data processing system to perform a method according to any of the Claims 1 to 12.

16. The method of Claim 1, wherein the threshold degree of separation is one, two, three, or all.

17. The method of Claim 1, further comprising:

receiving, from the first client system, a request to invite at least one of the selected second users referenced in the notification to the place associated with the third-party content provider; and

sending, in response to the request, a message to the second client system of the at least one selected second user.

18. The method of Claim 17, further comprising:

sending, to the first client system, updated location information for the at least one selected second user when a wireless communication system is established between the second client system of the at least one second user and the beacon.

19. The method of Claim 17, wherein the message comprises:

an invitation to join the first user at the place associated with the third-party content provider; and

a prompt to respond to the invitation.

20. The method of Claim 19, wherein the message further comprises location information of the place associated with the third-party content provider.

21. The method of Claim 19, wherein the message further comprises an identifier of at least one third user of an online social network, the at least one third user being associated with a

respective third client system, wherein a wireless communication session is active between the beacon and the third client system.

22. The method of Claim 1, further comprising receiving, from the beacon, session information for at least one second user.

23. The method of Claim 22, wherein the selecting of one or more second users is further based on the received session information of the at least one second user.

24. The method of Claim, 23 wherein the session information of the at least one second user comprises a history of one or more prior wireless communication sessions established between the beacon and the second client system of the at least one second user.

25. The method of Claim 1, wherein the selecting of one or more second users is further based on user preferences of at least one second user.

26. The method of Claim 25, wherein the user preferences of the at least one second user indicate a preference for a type of good or service, and wherein the third-party content provider comprises the preferred type of good or service.

27. The method of Claim 1, wherein the selecting of one or more second users is further based on an affinity coefficient of at least one second node with respect to a third node in the social graph, the third node corresponding to the third-party content provider.

28. The method of Claim 27, wherein the affinity coefficient is based on one or more edges connecting the at least one second node to the third node.

29. One or more computer-readable non-transitory storage media embodying software that is operable when executed to:

access a social graph comprising a plurality of nodes and a plurality of edges connecting the nodes, each of the edges between two of the nodes representing a single degree of separation between them, the nodes comprising:

a first node corresponding to a first user of the online social network, and

a plurality of second nodes respectively corresponding to a plurality of second users associated with the online social network, each second node being connected to the first node in the social graph by a threshold degree of separation;

receive, from a beacon associated with a third-party content provider, session information of the first user, wherein:

the beacon is associated with a particular location within a place associated with the third-party content provider, and

the session information of the first user indicates that a first client system of the first user is within wireless range of and proximate to the beacon, a wireless communication session being active between the beacon and the first client system;

select one or more of the second users, wherein the selecting is based on a second location of a second client system associated with the second user, the second location being within a threshold distance of the particular location of the beacon, and wherein a wireless communication session is not active between the beacon and each of second client systems associated with the selected second users; and

send, to the first client system of the first user, a notification referencing one or more of the selected second users.

30. The media of Claim 29, further comprising:

receiving, from the first client system, a request to invite at least one of the selected second users referenced in the notification to the place associated with the third-party content provider; and

sending, in response to the request, a message to the second client system of the at least one selected second user.

31. The media of Claim 30, further comprising:

sending, to the first client system, updated location information for the at least one selected second user when a wireless communication system is established between the second client system of the at least one second user and the beacon.

32. A system comprising: one or more processors; and a memory coupled to the processors comprising instructions executable by the processors, the processors being operable when executing the instructions to:

access a social graph comprising a plurality of nodes and a plurality of edges connecting the nodes, each of the edges between two of the nodes representing a single degree of separation between them, the nodes comprising:

a first node corresponding to a first user of the online social network, and

a plurality of second nodes respectively corresponding to a plurality of second users associated with the online social network, each second node being connected to the first node in the social graph by a threshold degree of separation;

receive, from a beacon associated with a third-party content provider, session information of the first user, wherein:

the beacon is associated with a particular location within a place associated with the third-party content provider, and

the session information of the first user indicates that a first client system of the first user is within wireless range of and proximate to the beacon, a wireless communication session being active between the beacon and the first client system;

select one or more of the second users, wherein the selecting is based on a second location of a second client system associated with the second user, the second location being within a threshold distance of the particular location of the beacon, and wherein a wireless

communication session is not active between the beacon and each of second client systems associated with the selected second users; and

send, to the first client system of the first user, a notification referencing one or more of the selected second users.

33. The system of Claim 32, further comprising:

receiving, from the first client system, a request to invite at least one of the selected second users referenced in the notification to the place associated with the third-party content provider; and

sending, in response to the request, a message to the second client system of the at least one selected second user.

34. The system of Claim 33, further comprising:

sending, to the first client system, updated location information for the at least one selected second user when a wireless communication system is established between the second client system of the at least one second user and the beacon.

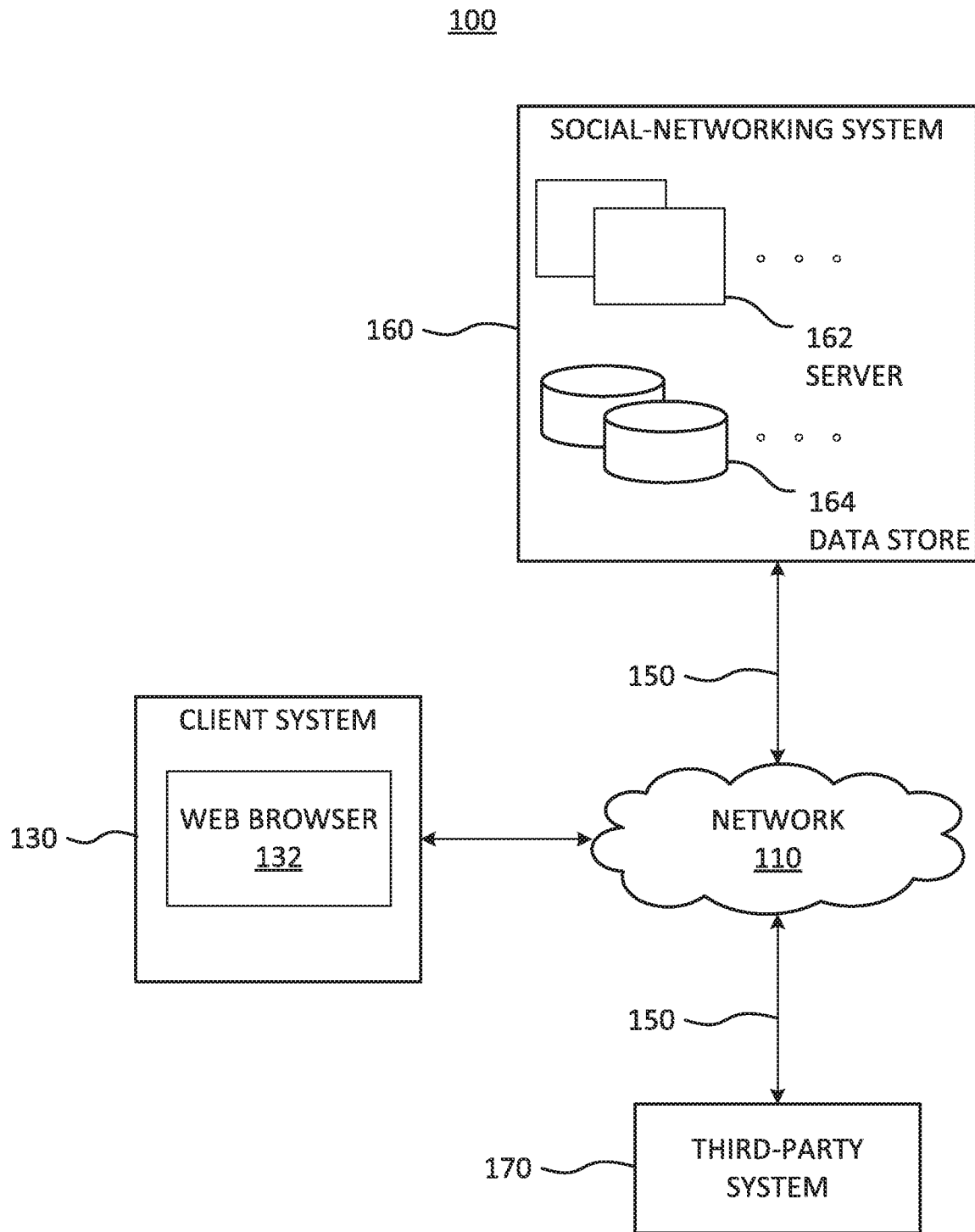

FIG. 1

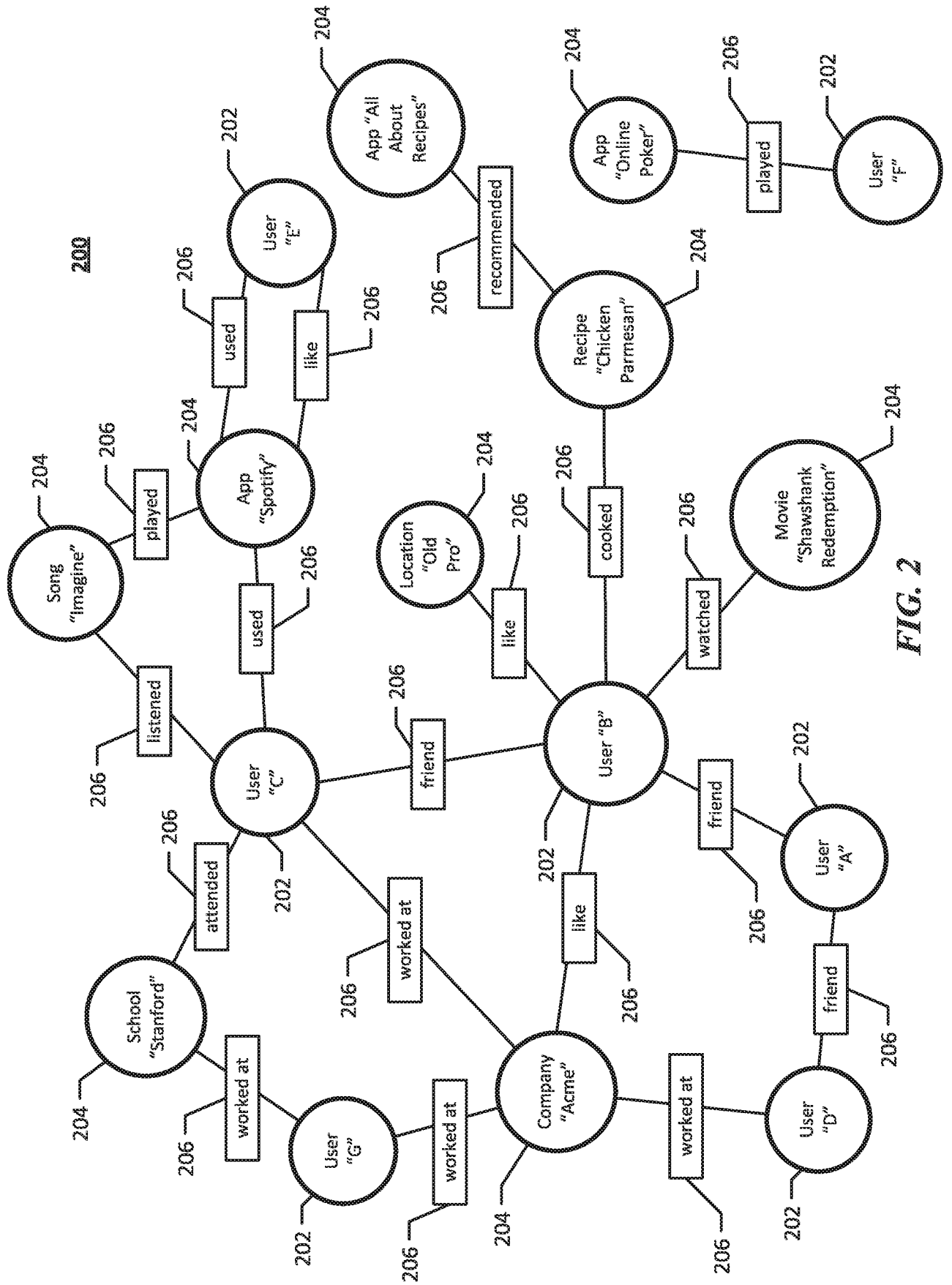

FIG. 2

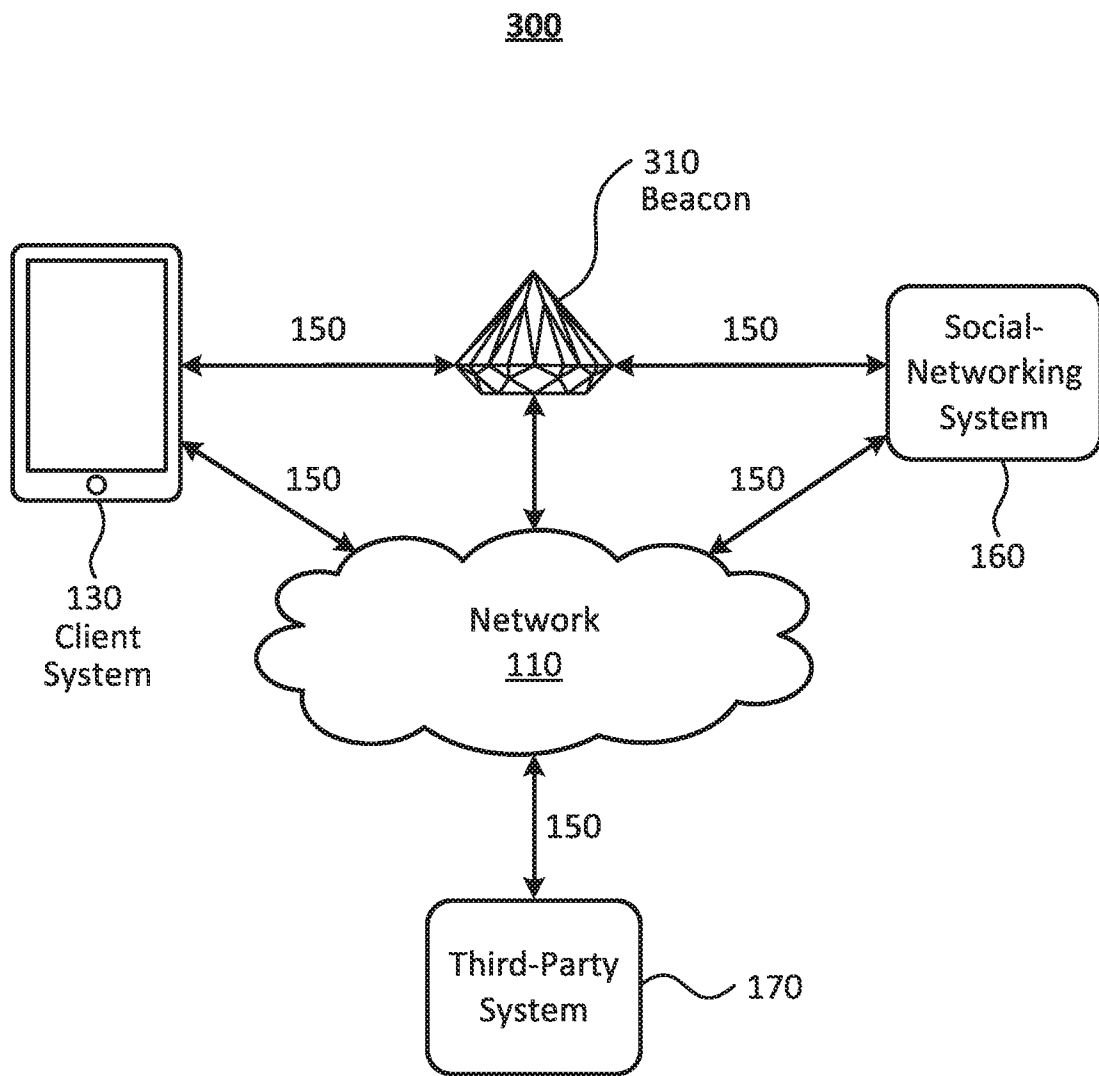

FIG. 3

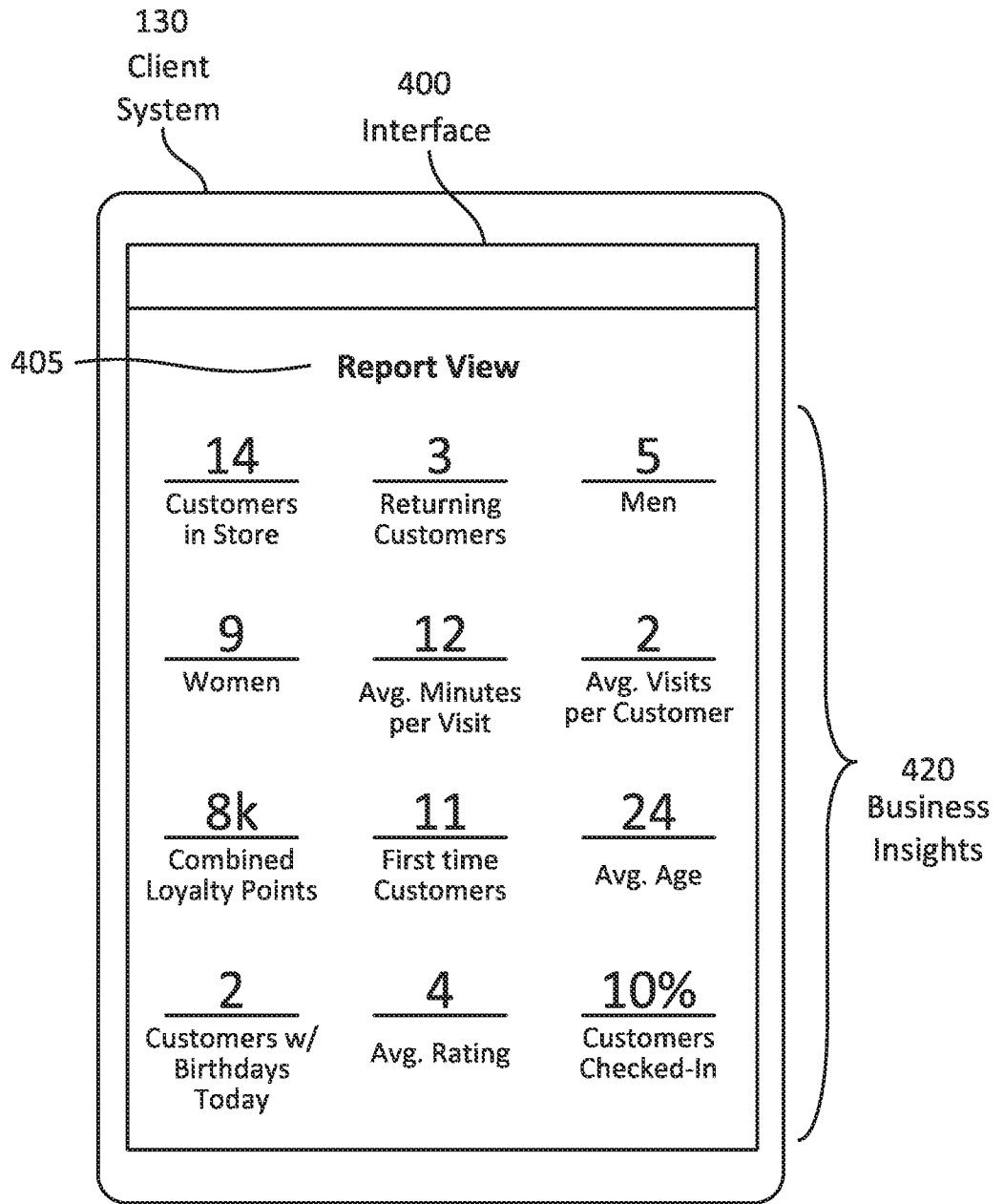

FIG. 4A

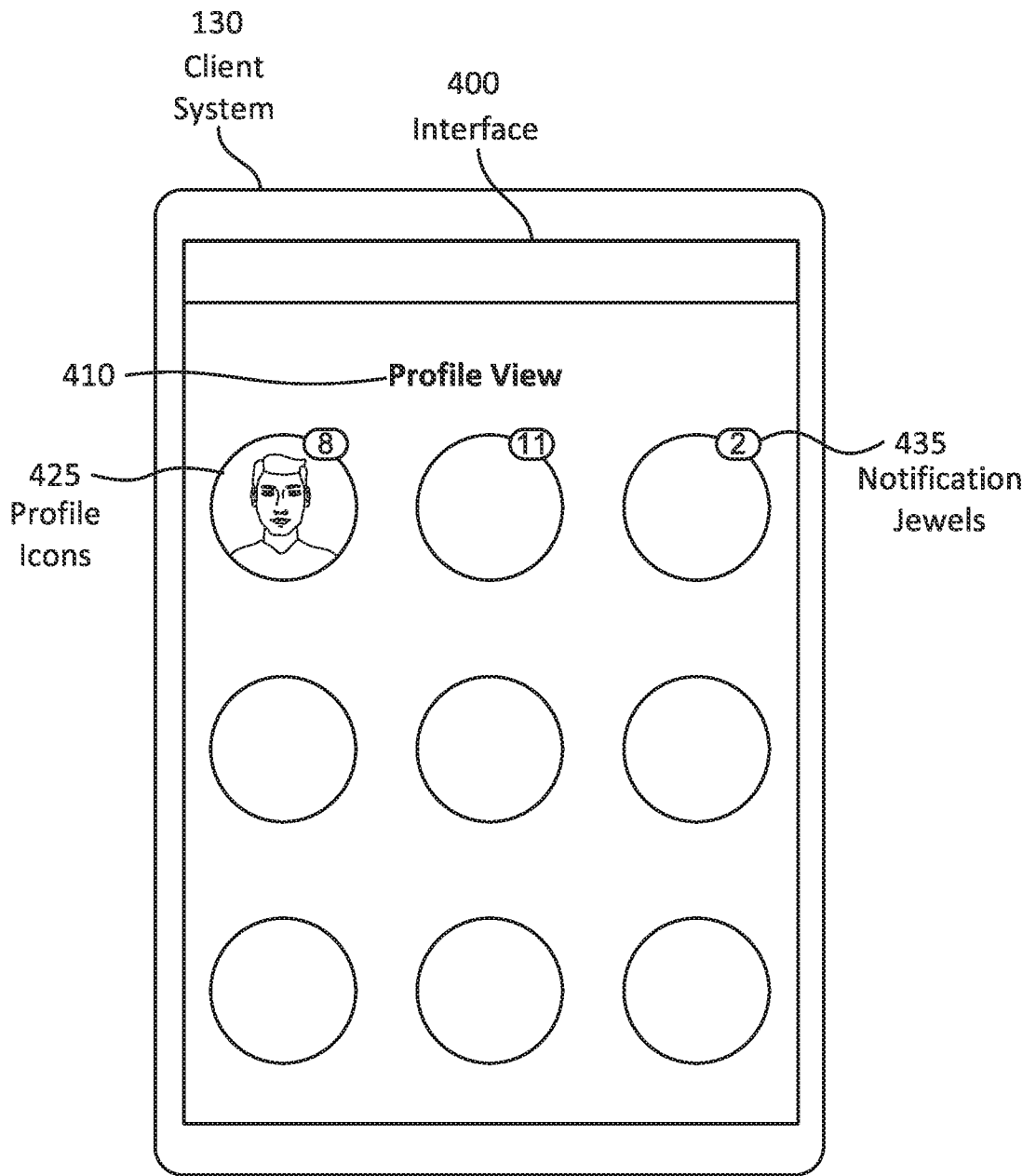

FIG. 4B

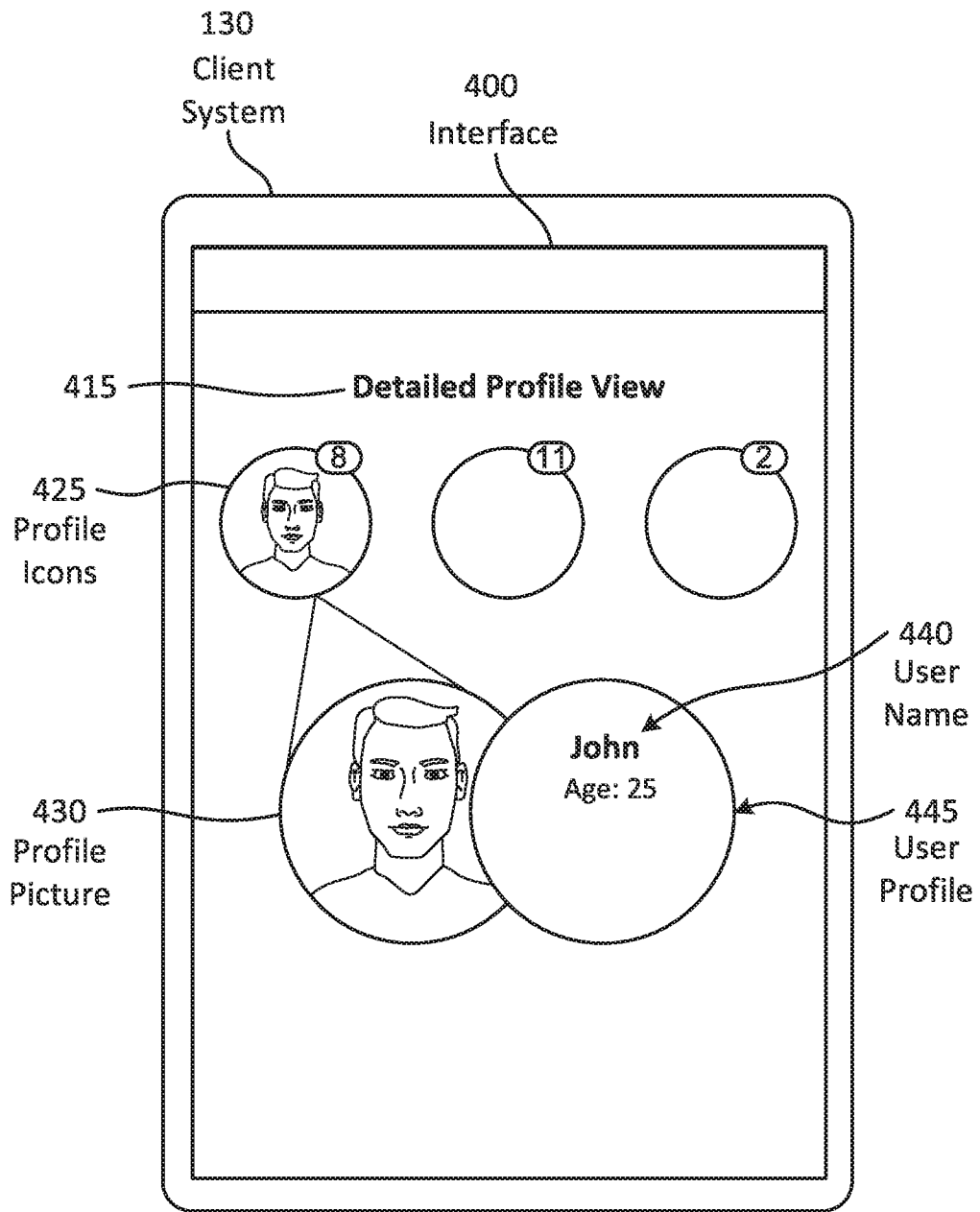

FIG. 4C

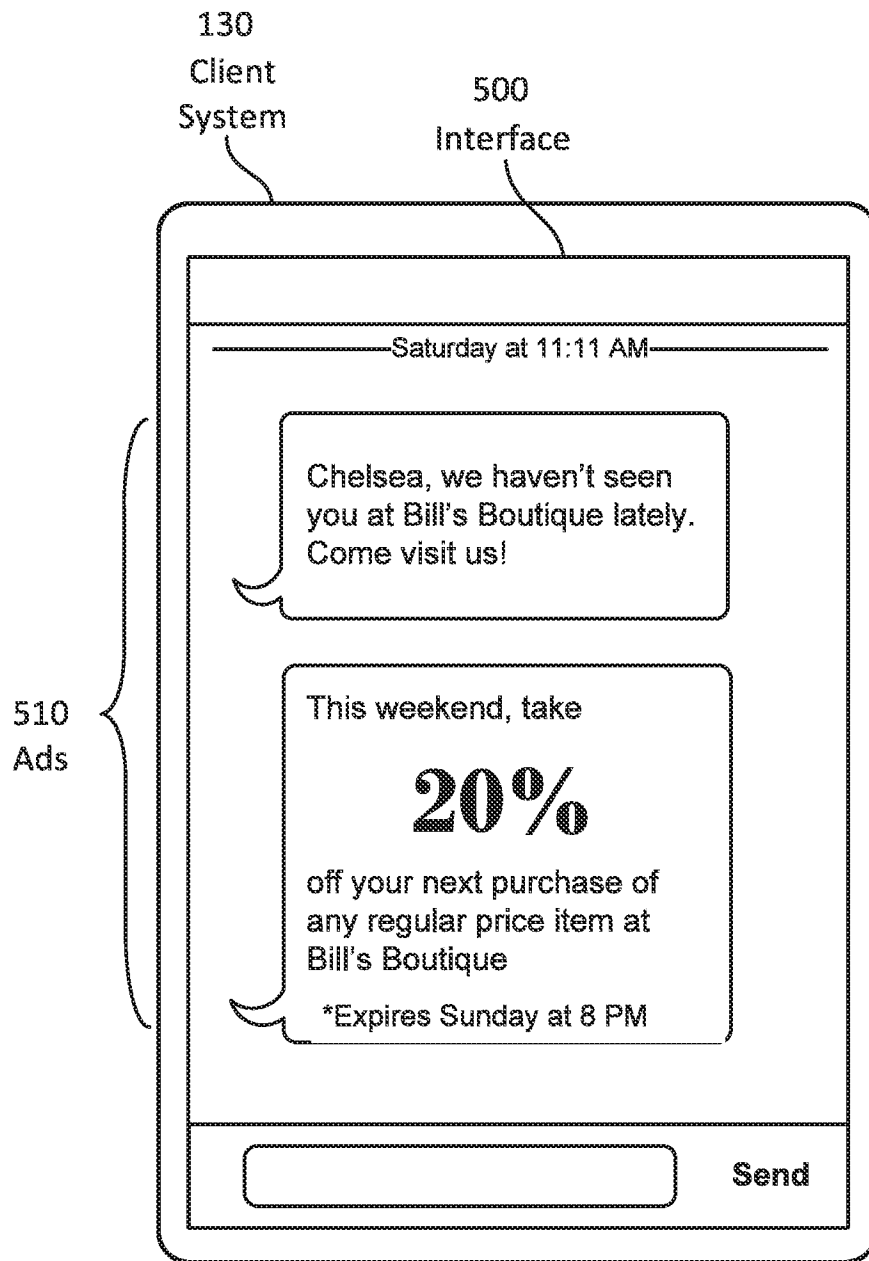
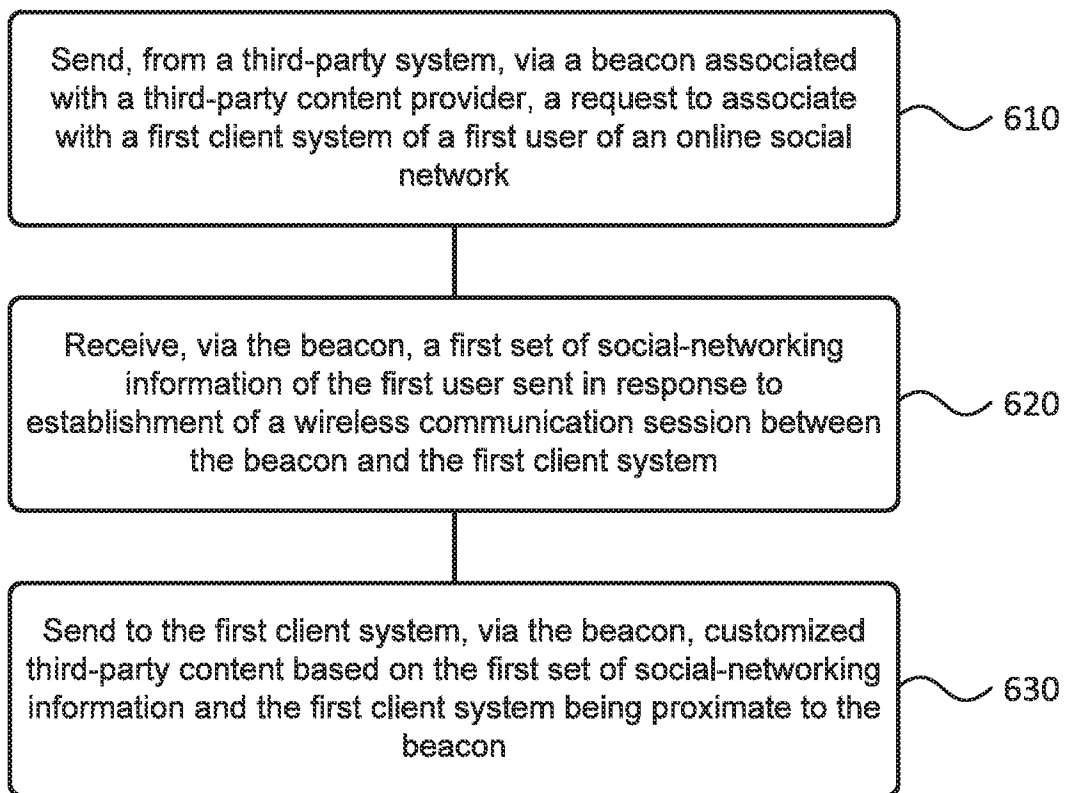
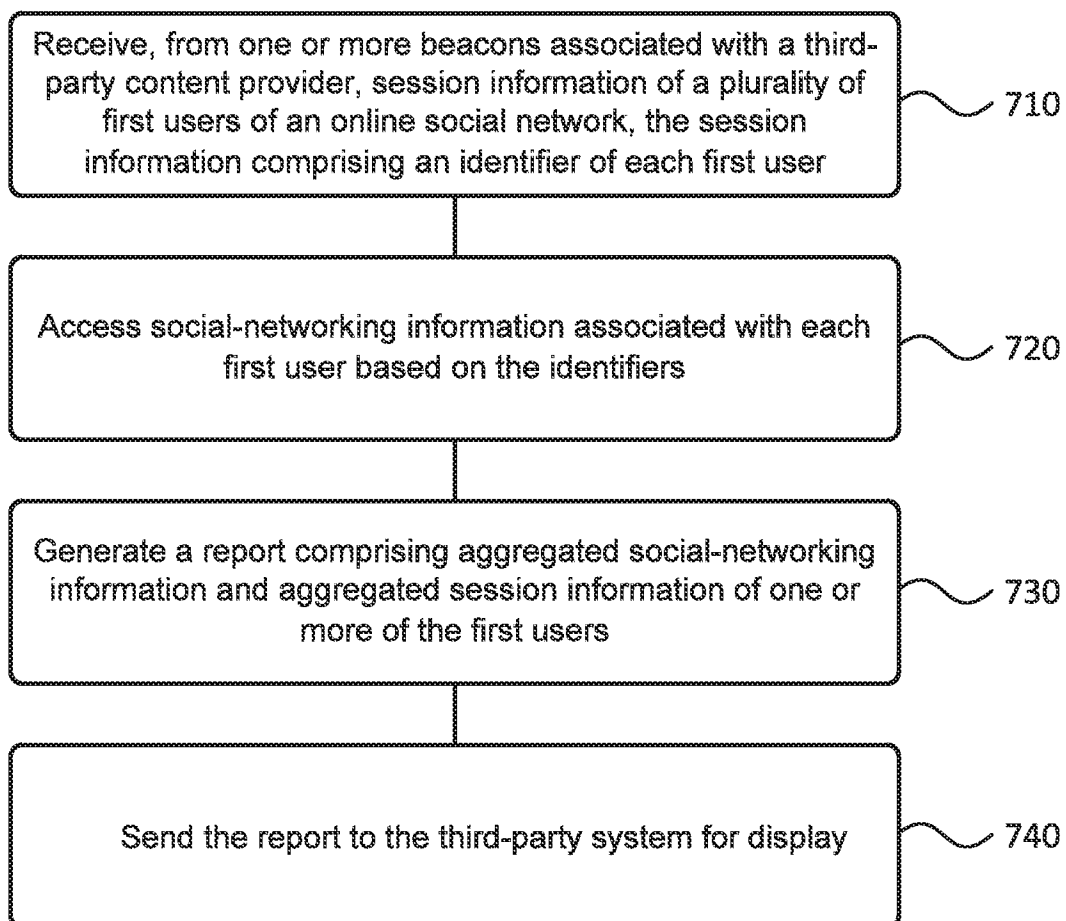

FIG. 5

600**FIG. 6**

700**FIG. 7**

800

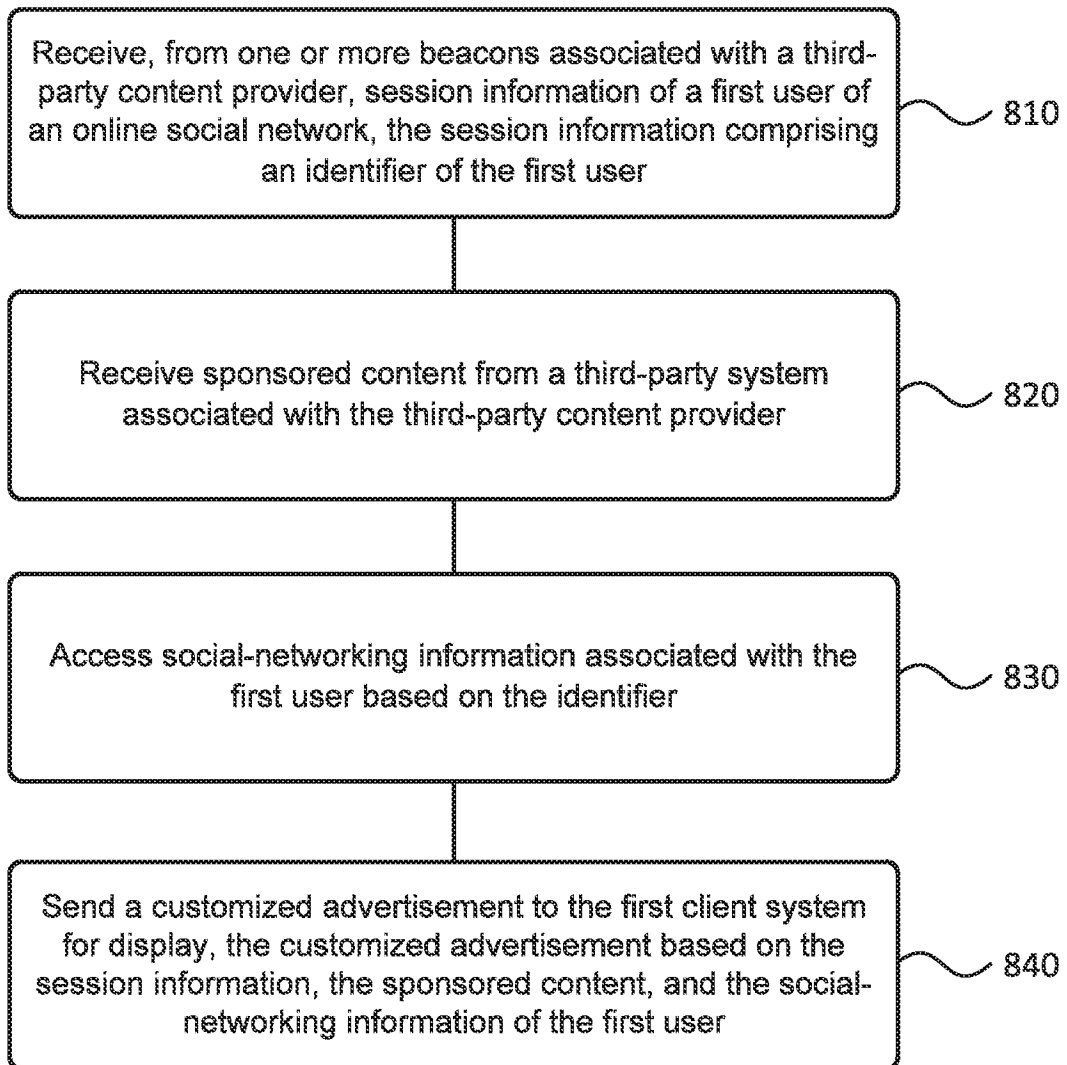

FIG. 8

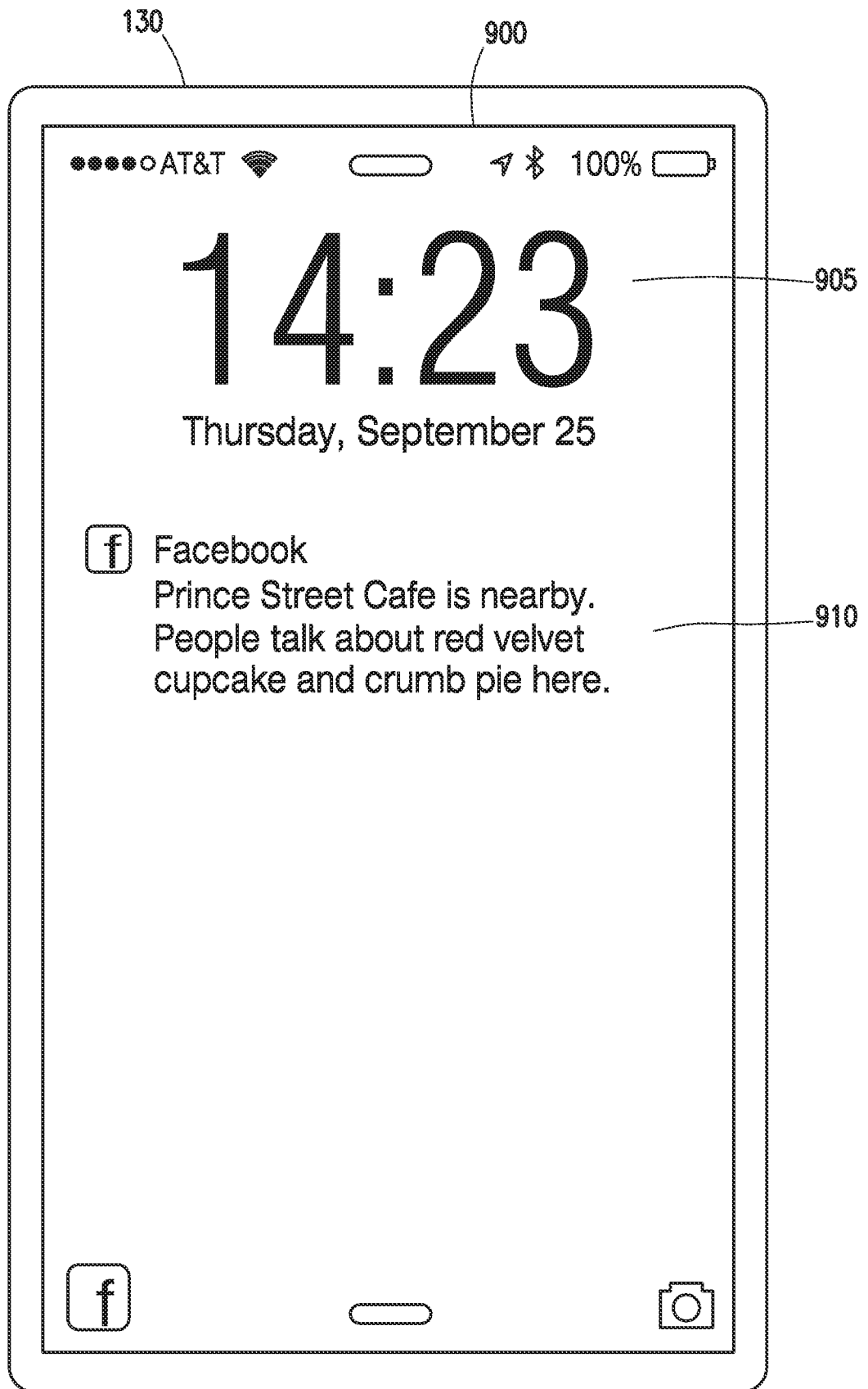

FIG. 9A



FIG. 9B

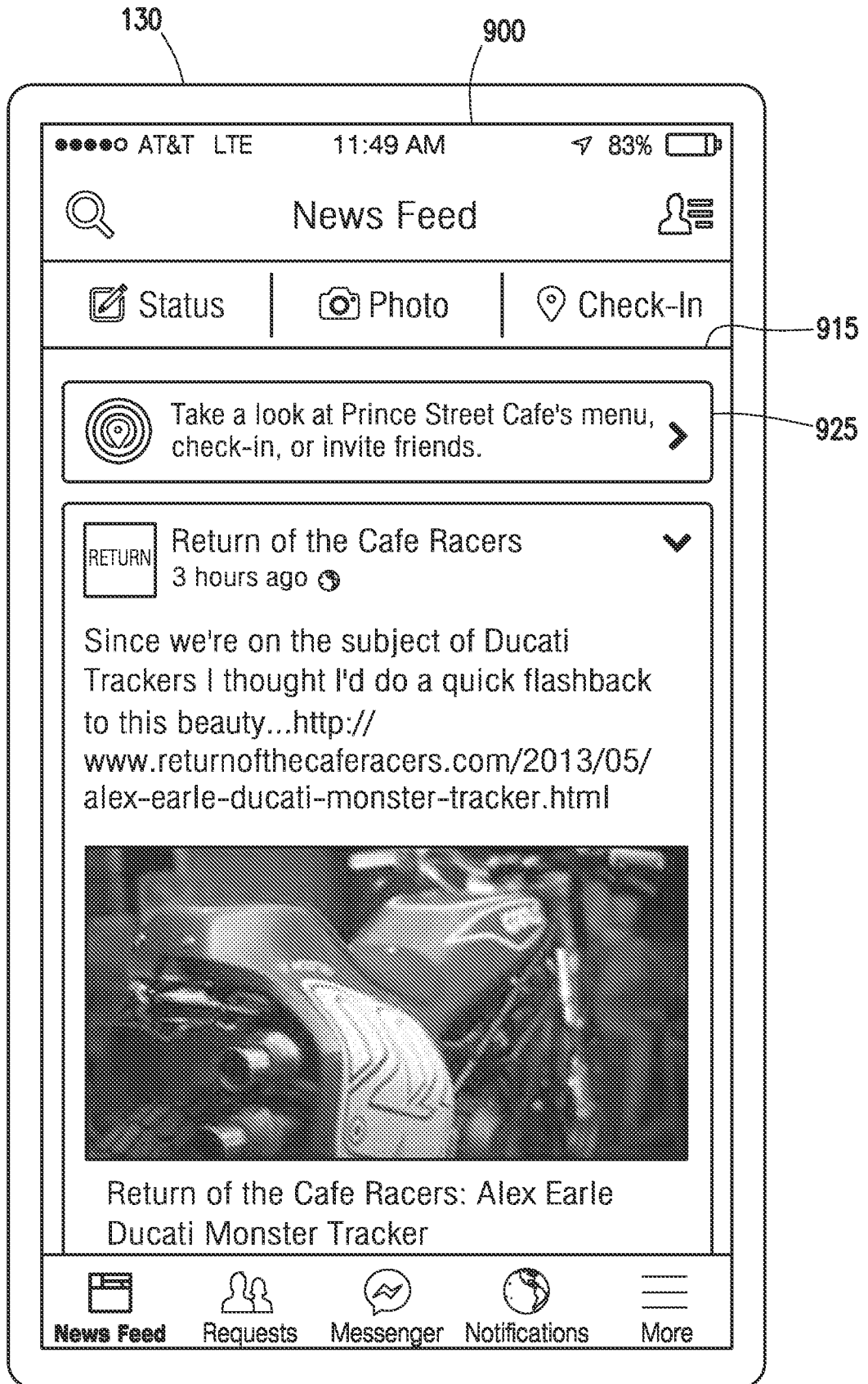

FIG. 9C

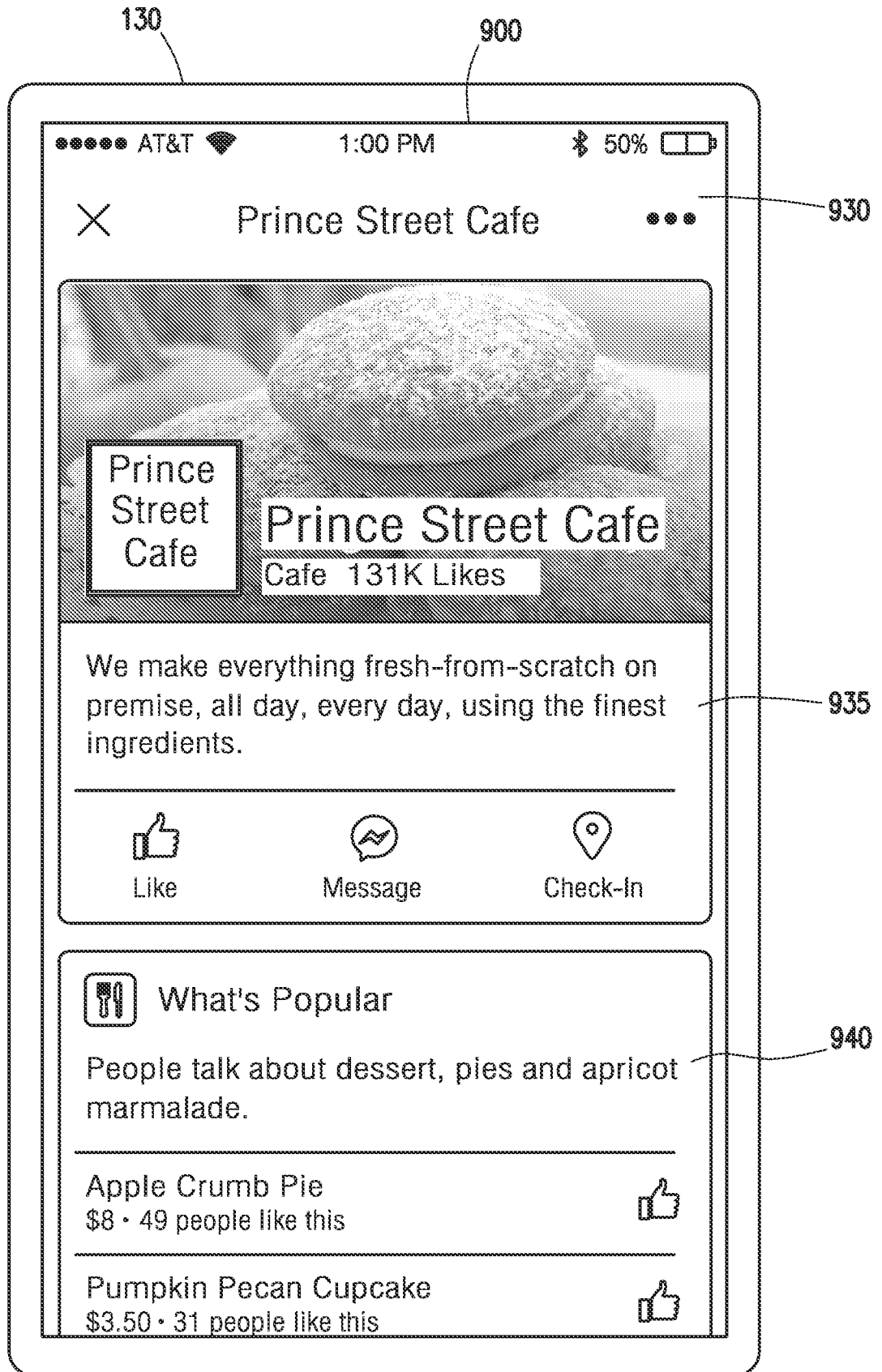

FIG. 9D

FIG. 9E

Prince Street Cafe 930 Done

Thanks for visiting Prince Street Cafe
We make everything fresh-from-scratch on premises, all day, every day, using the finest ingredients.

Like Page Message Check In

Latest post by Prince Street Cafe

Pumpkin spice lattes are back! Treat yourself to one this afternoon. 4 hours ago

View all posts

Events at Prince Street Cafe

SEP 17 7:00 PM • Celeste is going

SEP 19 7:00 PM • 7 friends are going

View all events

People talk about pizza, duck liver paté and best burger here.

How do you find the wait here?

Great Okay Bad

945

950

955

960

965

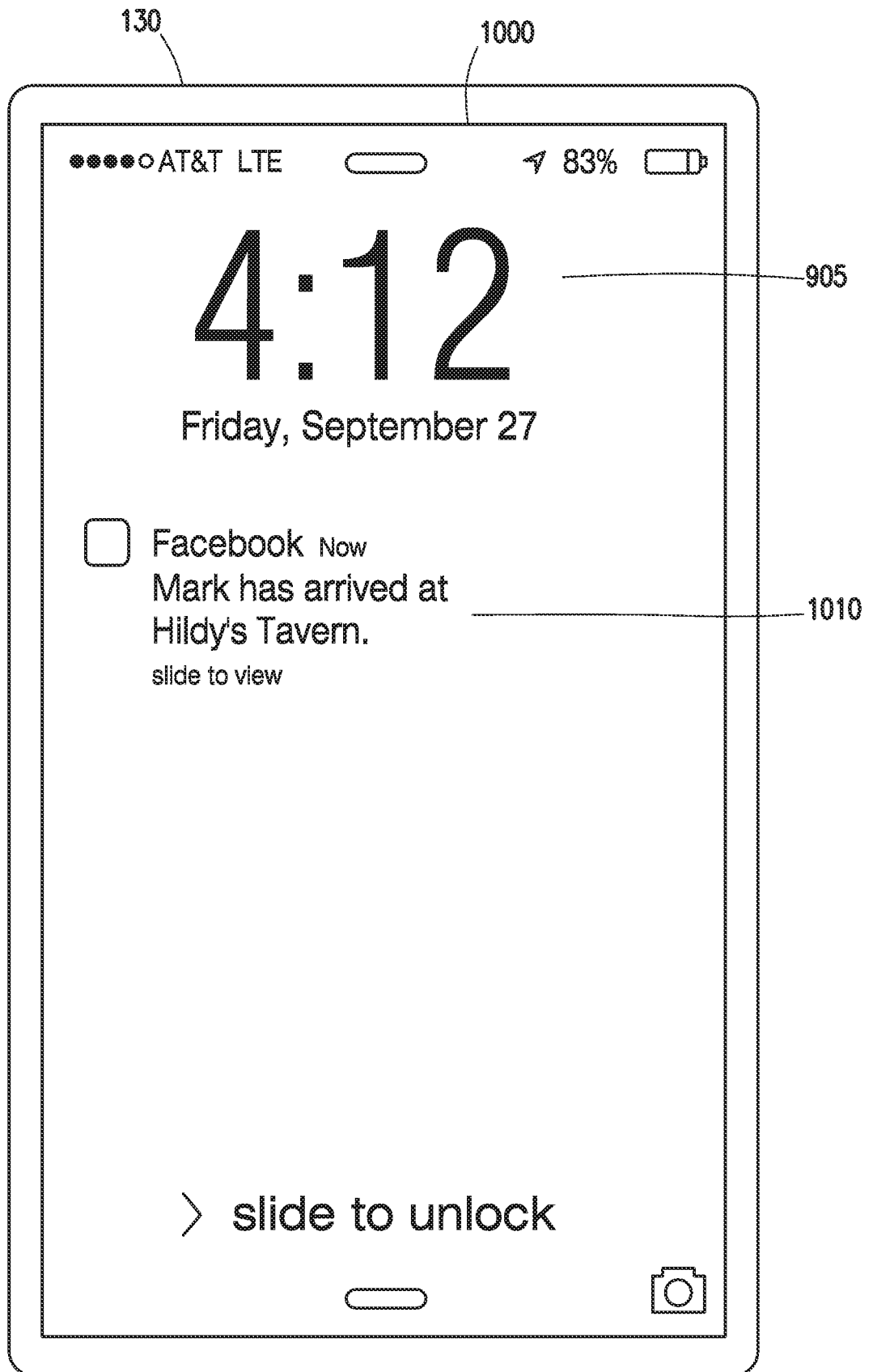

FIG. 10A

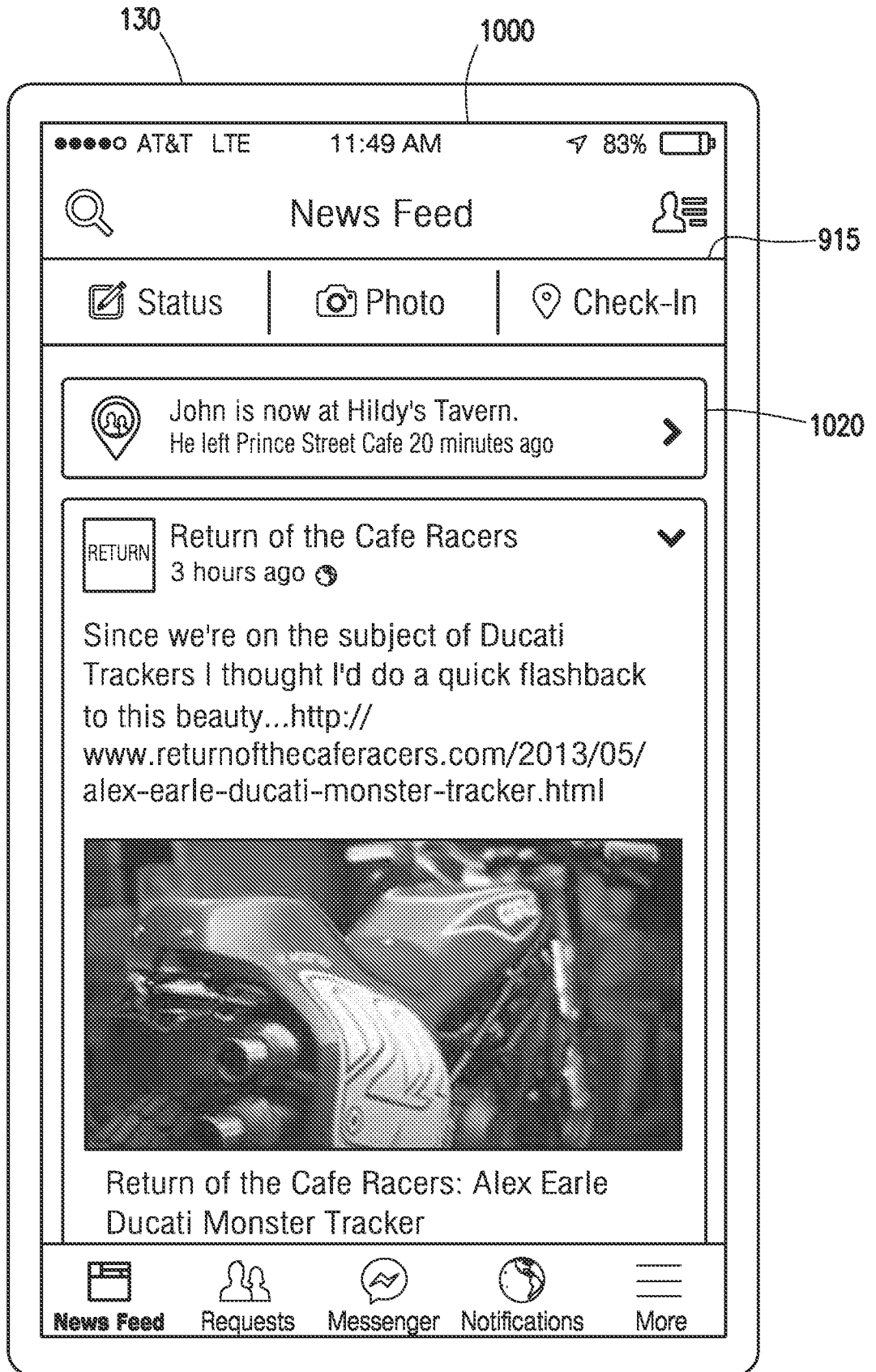

FIG. 10B



FIG. 10C



FIG. 11A

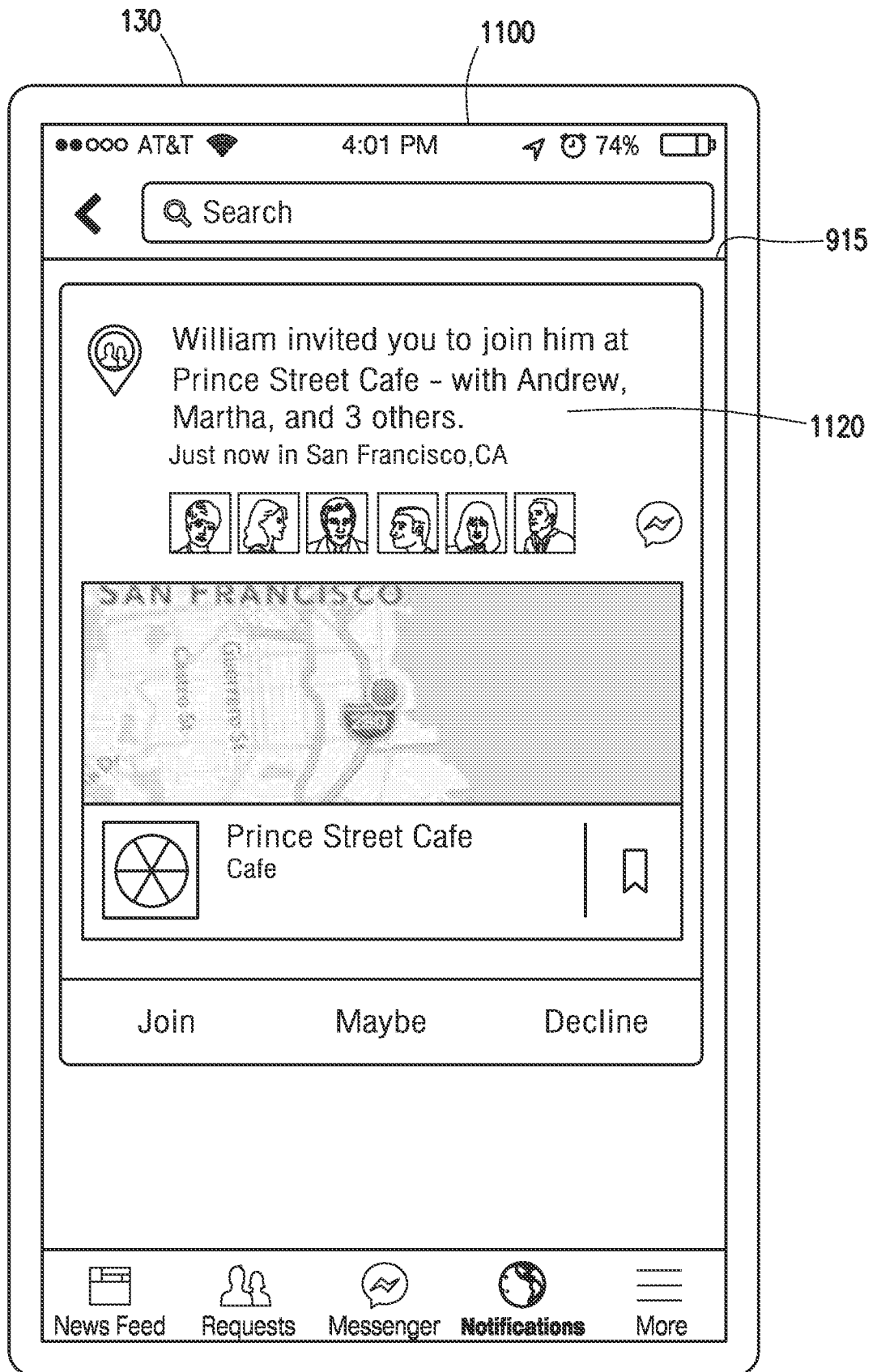

FIG. 11B

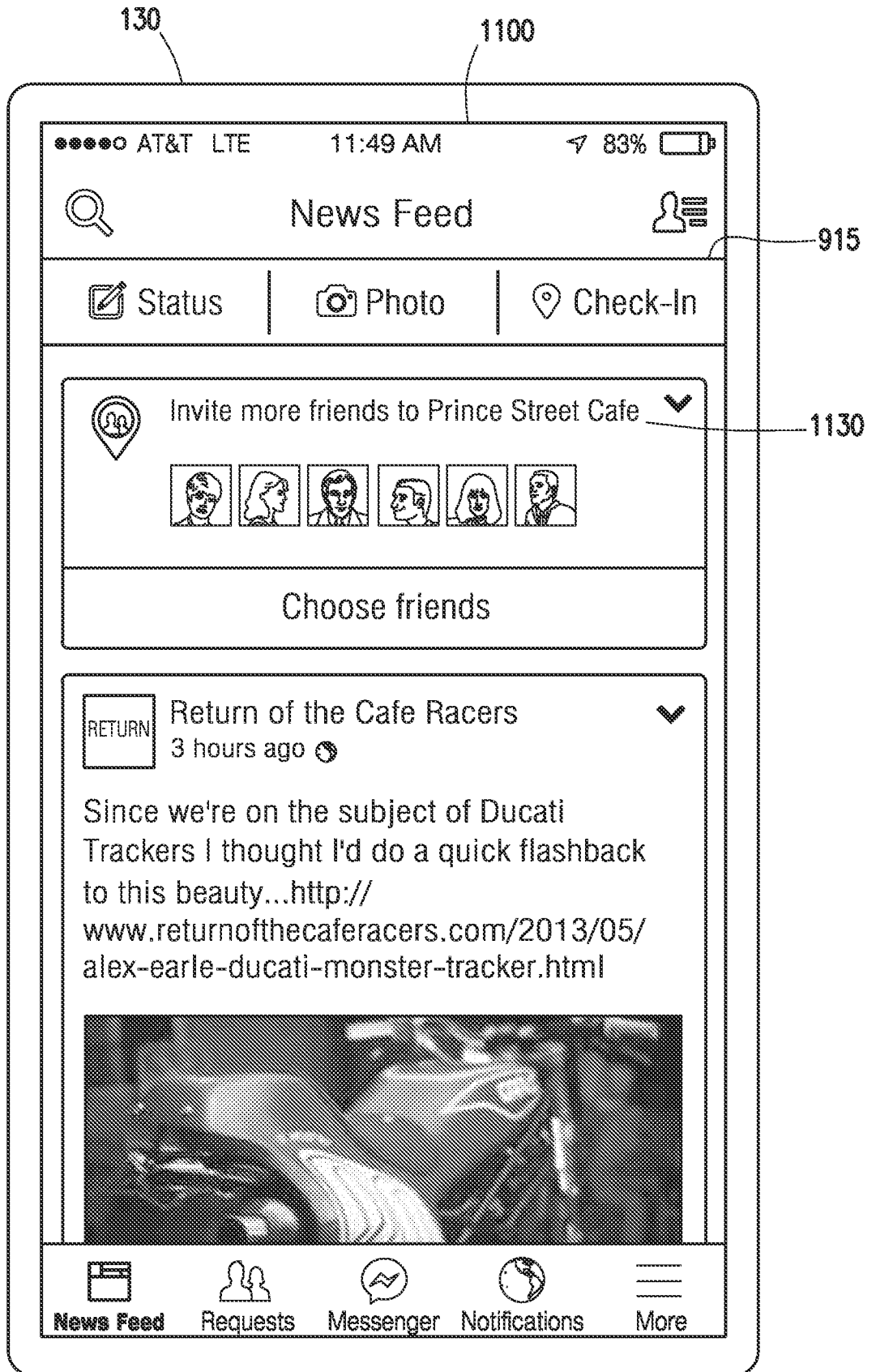

FIG. 11C

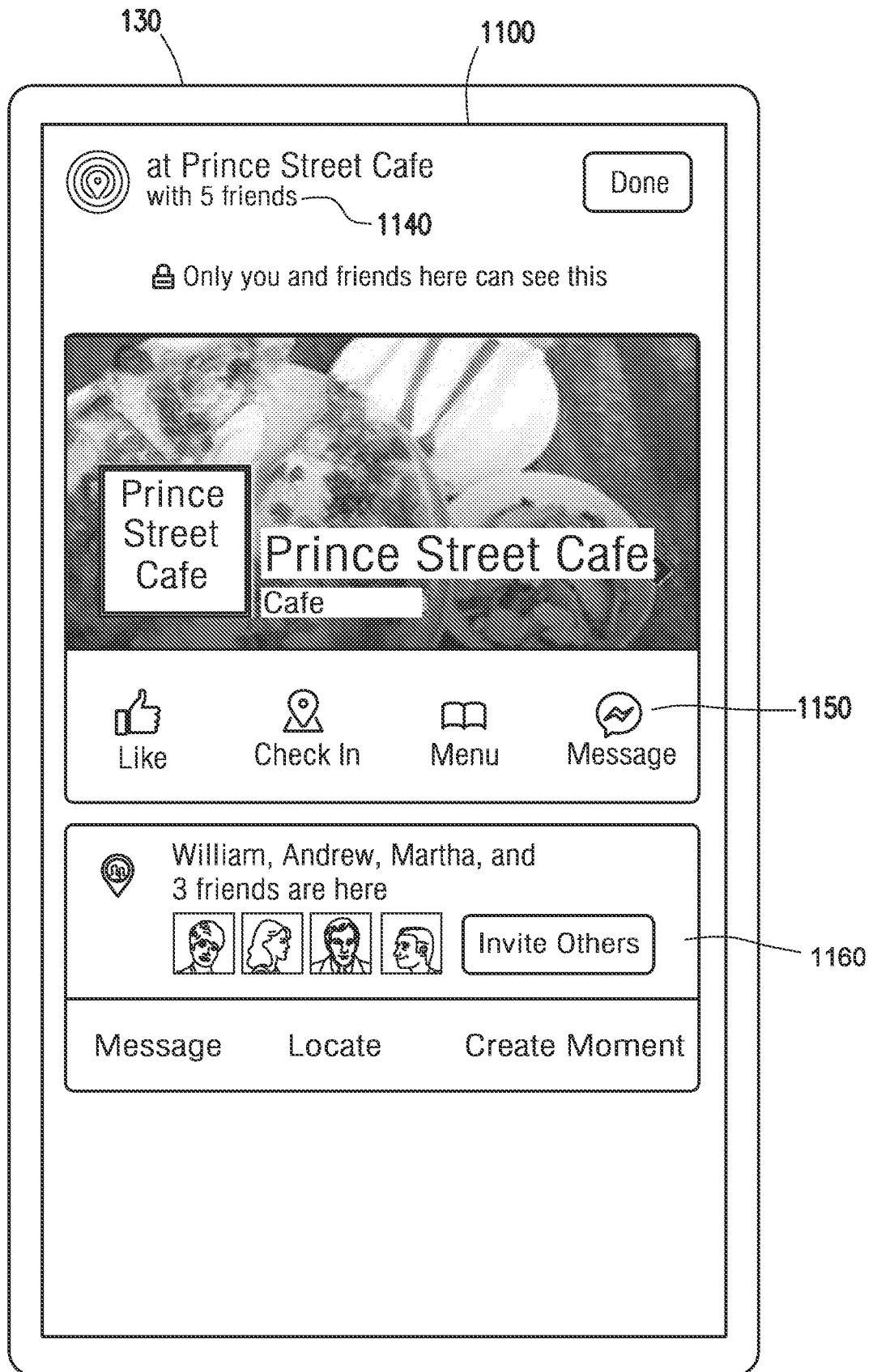

FIG. 11D

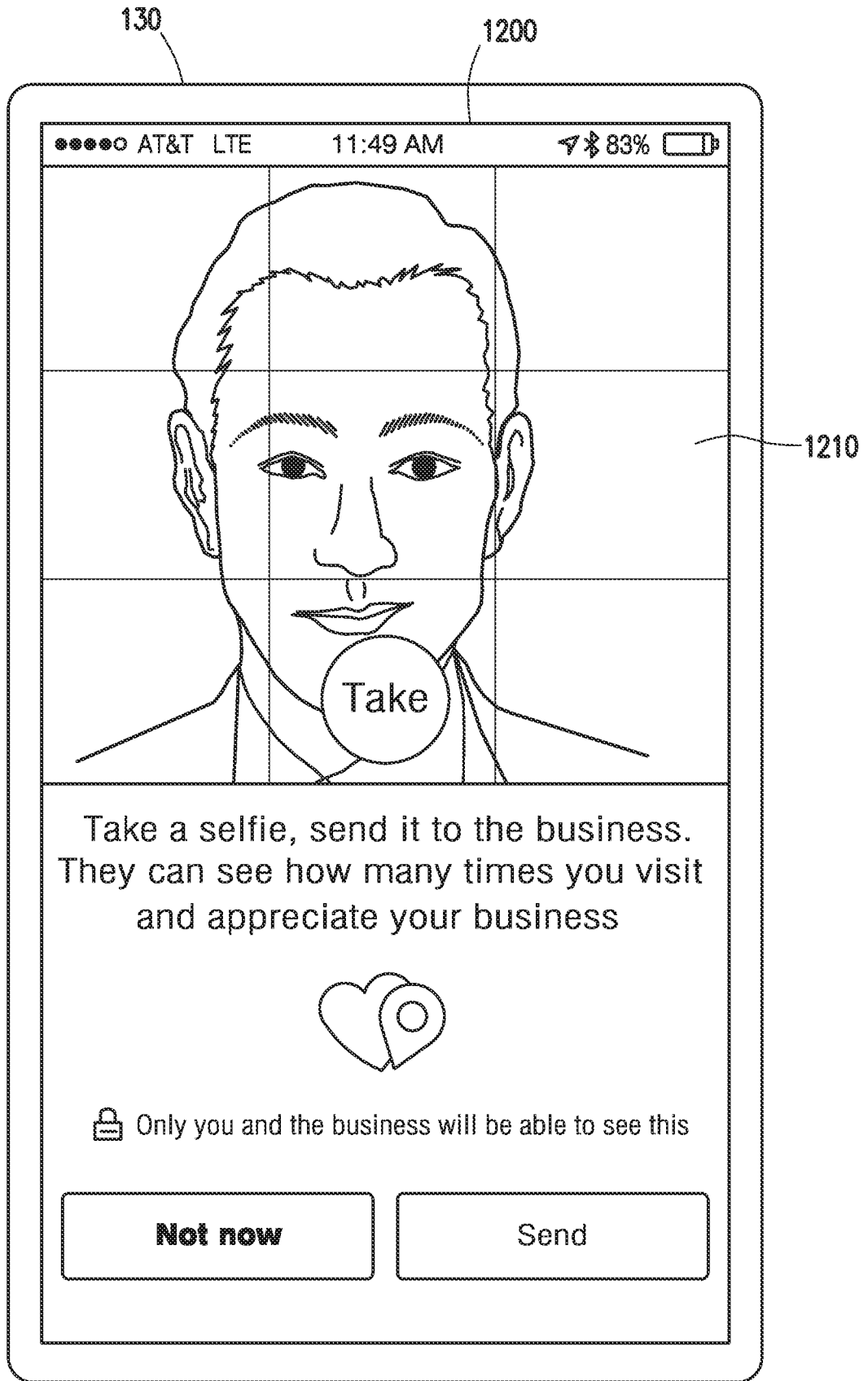

FIG. 12

Sheet 24/26

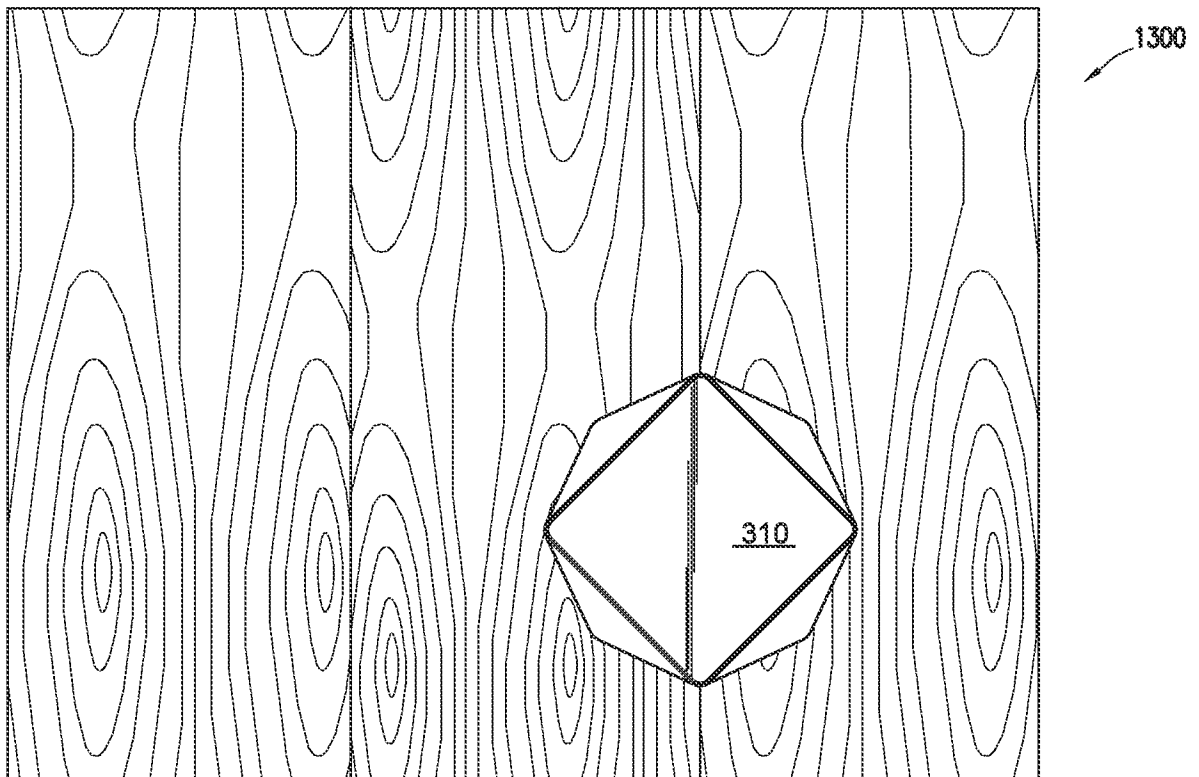
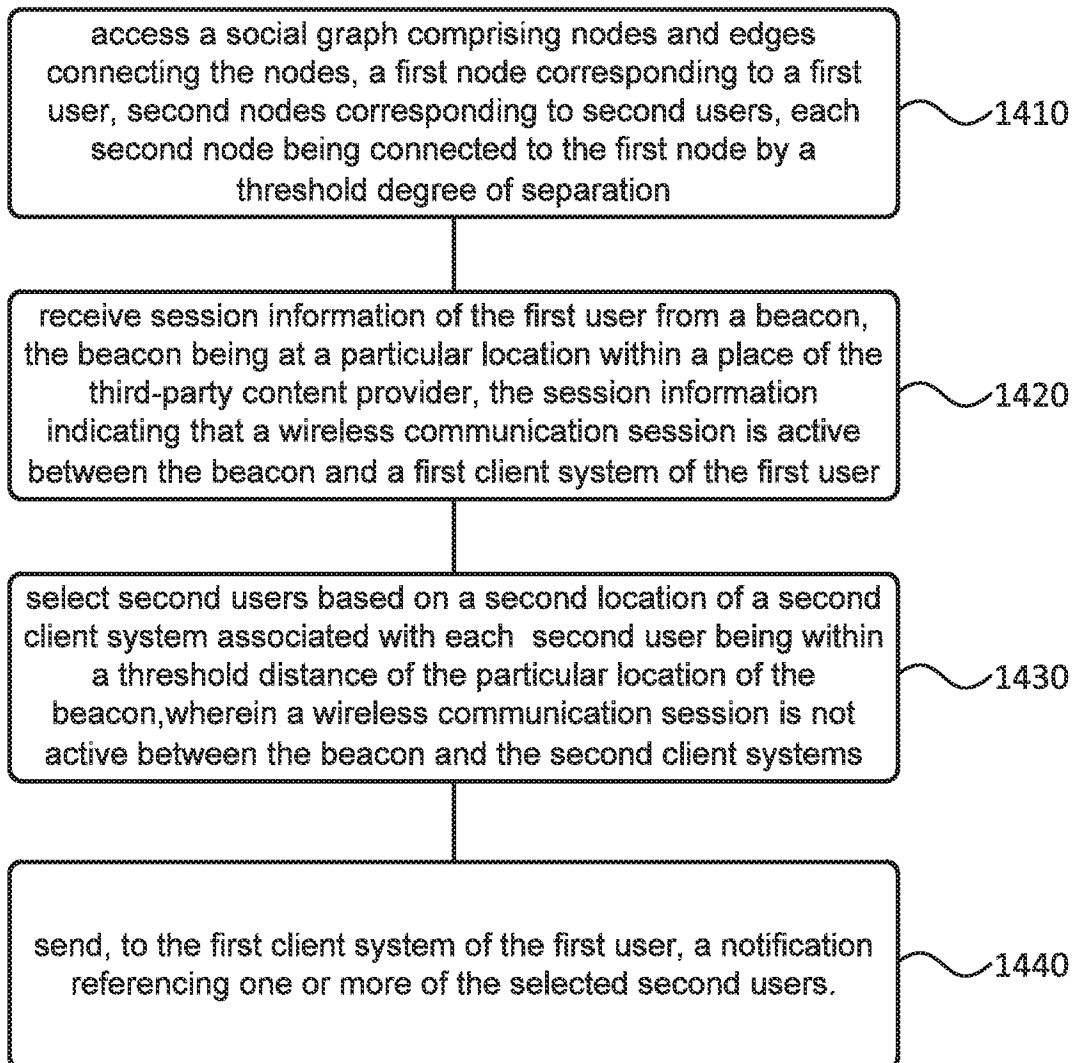

FIG. 13

1400**FIG. 14**

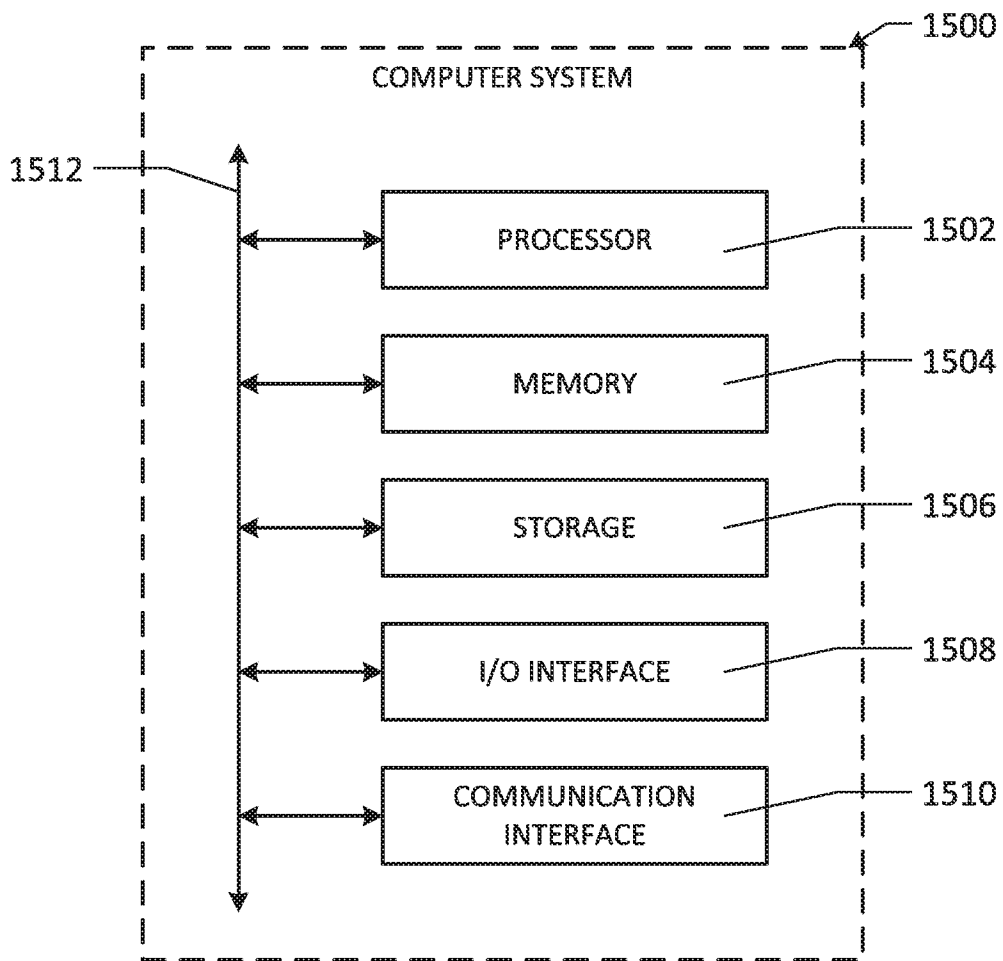

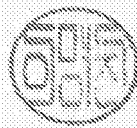

FIG. 15

INTERNATIONAL SEARCH REPORT

International application No.
PCT/US2014/069702

A. CLASSIFICATION OF SUBJECT MATTER G06Q 50/30(2012.01)i, H04W 4/02(2009.01)i		
According to International Patent Classification (IPC) or to both national classification and IPC		
B. FIELDS SEARCHED		
Minimum documentation searched (classification system followed by classification symbols) G06Q 50/30; G06F 15/16; G06Q 50/10; G06F 17/30; H04L 29/06; G06Q 50/10; G06Q 50/00; G06Q 10/02; H04W 4/02		
Documentation searched other than minimum documentation to the extent that such documents are included in the fields searched Korean utility models and applications for utility models Japanese utility models and applications for utility models		
Electronic data base consulted during the international search (name of data base and, where practicable, search terms used) eKOMPASS(KIPO internal) & Keywords: notification, beacon, social, graph, reference		
C. DOCUMENTS CONSIDERED TO BE RELEVANT		
Category*	Citation of document, with indication, where appropriate, of the relevant passages	Relevant to claim No.
Y	US 2014-0189530 A1 (FACEBOOK, INC.) 03 July 2014 See paragraphs [0028],[0030],[0032],[0052],[0054], claims 1,10 and figure 9.	1-6,16-34
Y	US 2014-0122136 A1 (MADHAVI JAYANTHI) 01 May 2014 See paragraphs [0009],[0028] and claims 1,6.	1-6,16-34
A	KR 10-2010-0057014 A (INTERTRUST TECHNOLOGIES CORPORATION) 28 May 2010 See abstract, claims 1-4,9 and figure 5.	1-6,16-34
A	US 2010-0138487 A1 (JOHN P. STAUTNER et al.) 03 June 2010 See paragraphs [0036]-[0037], claims 1,4-6 and figure 2.	1-6,16-34
A	KR 10-2012-0130345 A (QUALCOMM INCORPORATED) 30 November 2012 See abstract, claims 1,6,14-15 and figure 2.	1-6,16-34
<input type="checkbox"/> Further documents are listed in the continuation of Box C. <input checked="" type="checkbox"/> See patent family annex.		
* Special categories of cited documents: "A" document defining the general state of the art which is not considered to be of particular relevance "E" earlier application or patent but published on or after the international filing date "L" document which may throw doubts on priority claim(s) or which is cited to establish the publication date of another citation or other special reason (as specified) "O" document referring to an oral disclosure, use, exhibition or other means "P" document published prior to the international filing date but later than the priority date claimed		"T" later document published after the international filing date or priority date and not in conflict with the application but cited to understand the principle or theory underlying the invention "X" document of particular relevance; the claimed invention cannot be considered novel or cannot be considered to involve an inventive step when the document is taken alone "Y" document of particular relevance; the claimed invention cannot be considered to involve an inventive step when the document is combined with one or more other such documents, such combination being obvious to a person skilled in the art "&" document member of the same patent family
Date of the actual completion of the international search 21 August 2015 (21.08.2015)		Date of mailing of the international search report 24 August 2015 (24.08.2015)
Name and mailing address of the ISA/KR  International Application Division Korean Intellectual Property Office 189 Cheongsa-ro, Seo-gu, Daejeon Metropolitan City, 302-701, Republic of Korea Facsimile No. +82-42-472-7140		Authorized officer LEE, Myung Jin Telephone No. +82-42-481-8474 

INTERNATIONAL SEARCH REPORT

International application No.
PCT/US2014/069702

Box No. II Observations where certain claims were found unsearchable (Continuation of item 2 of first sheet)

This international search report has not been established in respect of certain claims under Article 17(2)(a) for the following reasons:

- 1. Claims Nos.:
because they relate to subject matter not required to be searched by this Authority, namely:

- 2. Claims Nos.: 8,10,12
because they relate to parts of the international application that do not comply with the prescribed requirements to such an extent that no meaningful international search can be carried out, specifically:
Claims 8,10,12 are regarded to be unclear because the claims refer to multiple dependent claims which do not comply with PCT Rule 6.4(a).

- 3. Claims Nos.: 7,9,11,13-15
because they are dependent claims and are not drafted in accordance with the second and third sentences of Rule 6.4(a).

Box No. III Observations where unity of invention is lacking (Continuation of item 3 of first sheet)

This International Searching Authority found multiple inventions in this international application, as follows:

- 1. As all required additional search fees were timely paid by the applicant, this international search report covers all searchable claims.

- 2. As all searchable claims could be searched without effort justifying an additional fees, this Authority did not invite payment of any additional fees.

- 3. As only some of the required additional search fees were timely paid by the applicant, this international search report covers only those claims for which fees were paid, specifically claims Nos.:

- 4. No required additional search fees were timely paid by the applicant. Consequently, this international search report is restricted to the invention first mentioned in the claims; it is covered by claims Nos.:

- Remark on Protest**
- The additional search fees were accompanied by the applicant's protest and, where applicable, the payment of a protest fee.
 - The additional search fees were accompanied by the applicant's protest but the applicable protest fee was not paid within the time limit specified in the invitation.
 - No protest accompanied the payment of additional search fees.

INTERNATIONAL SEARCH REPORT

Information on patent family members

International application No.

PCT/US2014/069702

Patent document cited in search report	Publication date	Patent family member(s)	Publication date
US 2014-0189530 A1	03/07/2014	AU 2013-370202 A1 WO 2014-106115 A1	03/07/2014 03/07/2014
US 2014-0122136 A1	01/05/2014	US 2009-235176 A1	17/09/2009
KR 10-2010-0057014 A	28/05/2010	AU 2008-282886 A1 AU 2008-282886 B2 CA 2694200 A1 CN 101809980 A CN 101809980 B EP 2171997 A1 JP 05113253 B2 JP 2010-534882 A MX 2010001101 A US 08565781 B2 US 2009-029718 A1 US 2014-148203 A1 WO 2009-017702 A1	05/02/2009 29/11/2012 05/02/2009 18/08/2010 10/12/2014 07/04/2010 09/01/2013 11/11/2010 25/06/2010 22/10/2013 29/01/2009 29/05/2014 05/02/2009
US 2010-0138487 A1	03/06/2010	EP 0834798 A2 EP 0834798 A3 JP 10-143349 A US 06172677 B1 US 06600503 B2 US 07418672 B2 US 07694235 B2 US 08108797 B2 US 08578296 B2 US 2001-0012020 A1 US 2004-0017388 A1 US 2009-0025033 A1 US 2012-110512 A1 US 2014-215400 A1	08/04/1998 31/03/1999 29/05/1998 09/01/2001 29/07/2003 26/08/2008 06/04/2010 31/01/2012 05/11/2013 09/08/2001 29/01/2004 22/01/2009 03/05/2012 31/07/2014
KR 10-2012-0130345 A	30/11/2012	CN 102138344 A EP 2335163 A2 JP 05666452 B2 JP 2012-501616 A JP 2013-118666 A JP 2015-043589 A JP 2015-043590 A KR 10-2011-0050729 A KR 10-2013-0108465 A KR 10-2014-0049039 A KR 10-2014-0136510 A TW 201016052 A US 2010-0057924 A1 WO 2010-027714 A2 WO 2010-027714 A3	27/07/2011 22/06/2011 12/02/2015 19/01/2012 13/06/2013 05/03/2015 05/03/2015 16/05/2011 02/10/2013 24/04/2014 28/11/2014 16/04/2010 04/03/2010 11/03/2010 24/06/2010

INTERNATIONAL SEARCH REPORT

Information on patent family members

International application No.

PCT/US2014/069702

Patent document cited in search report	Publication date	Patent family member(s)	Publication date
		WO 2010-027714 A9	11/03/2010