

(19)  
(12)

(KR)  
(B1)

(51) 。 Int. Cl.<sup>7</sup>  
G11C 29/00

(45)  
(11)  
(24)

2004 02 25  
10-0419814  
2004 02 10

(21) 10-2001-0081615  
(22) 2001 12 20

(65)  
(43)

10-2002-0066946  
2002 08 21

(30) JP-P-2001-00037267 2001 02 14 (JP)  
JP-P-2001-00152147 2001 05 22 (JP)

(73) 가 가 2 2 3

(72) 2 2-3 가 가  
2 2-3 가 가  
2 2-3 가 가  
가 2 2-3 가 가

(74)

:

(54) 가

(300) (400) (400) DRAM (100.1 100.n)  
(300)  
(400) DRAM

1

, DRAM , ,

1				(1000)			
2	1	DRAM	(100.1)				
3	1			(300)			
4							
5	4		가				
6a	6c						
7			ARD				
8		MCR11	MCR12	CAM			
9		(CAM	)				
10	1			(400)			
11	CAM	(4000)		+S/A	(4020	4030)	
12		+S/A	(4020)	/		(4020V)	
13		+S/A	(4020)	/		(4020F)	
14	10			(4100.1)			
15	14		SEL1				
16	15		LT451				
17		SEL1		(4010)			
18	1			(500.1)			
19		(510.1)					
20		(520.1)					
21			(300)			(400)	1
22			(300)			(400)	2
23	2			(34)			
24		(330)		(344)		(342)	
25	24			(330)			
26	2			(2000)			
27	26		, DRAM	(114)			
28		(116.1	116.n),	(118.1	118.n),	(120.1	120.n)
29	DRAM	(100)					
30			(400)		CAM	(4000)	
31	30	CAM					
32	31	CAM			PA		
33	CAM	(4000)					
34	33	CAM					
35	CAM	MC'n1					
36	34	CAM			CAM		CAM
37	CAM						
38	37	CAM		CAM			
39	CAM						
40							
41		+S/A	(4020)	/		(4020V)	
42		+S/A	(4020)	/		(4020F)	



56 (8030)가 (8000) DRAM (8010) , (8030) , 2 (8030)  
 , 8 , I/O 가 , ,  
 (8000) ,  
 , DRAM (8010) 가 , 가 .  
 (8100) , (8030) DRAM (8010) DRAM (8000)  
 (8100) (8030)  
 , DRAM (8010) (8100) , D  
 RAM (8010) 가 , DRAM (8010) 가 .  
 (8100)  
 44 43 (8000) DRAM (8010)  
 , / (8230) (8200)  
 (Built-in self test) 「BIST」  
 (8200) DRAM (8210) , DRAM (8210)  
 (8220) , DRAM (8210) , DRAM (8210)  
 / (8230)  
 / (8230) , 2001-6387 ,  
 1: T.Kawagoe, J.Ohtani, M.Niuro, T. Ooishi, M.Hamada, and H.Hidaka, "A Built-In Self-Repair Analyzer(CRES  
 TA) for embedded DRAMs", International Test Conference 2000 proceedings, pp. 567-574.  
 , 44 / (8230) (8200)  
 , DRAM (8210) / (8230)  
 , 256 I/O , 43  
 , , DRAM 가 1 ,  
 45 1 DRAM 가 (8400)  
 (8400) 1 DRAM (8410) 2 DRAM (8440)가 1 DRAM  
 (8410) DRAM (8410)  
 (8420) , DRAM (8410)  
 / (8430)가  
 , 2 DRAM (8440) DRAM (8440)  
 (8450) , DRAM (8440)  
 / (8460)가  
 , DRAM (8440) DRAM (8410)  
 , DRAM (8410) / (8430) 256  
 2048 , DRAM (8440) , / (8460)  
 , DRAM (8410) DRAM (8440)  
 0) / (8430) DRAM (8410) DRAM (844  
 460)가 가 . (8)  
 , DRAM /  
 가 ,

DRAM

가

, DRAM

1  
1

2

가

가

[ 1 ]

[ (1000) ]

(1000)

(1000) n (n: ) DRAM (100.1 100.n) , DRAM (200.1 200.n) ,

(100.1 100.n) , DRAM (100.1 100.n) (300) ,

DRAM (100.1 100.n) (300)

, DRAM (100.1 100.n) (400)

, DRAM 가

가

(300) MCLK가 (300) (20) (16) RDC가 (12) RST가 (14) TS가

가 가 가 가

(22) 가 (18) 가 (24) TE가

DRAM (100.1) 가 (200.1) DE가 (500.1)가 DRAM (100.1) (200.1) (200.2) DRAM (100.n) (200.n)

DRAM (100.2) (500.2 500.n)가 DRAM (100.1 100.n) (200.1 200.n) (500.1 500.n)

DE1 DEn (500.1 500.n) DRAM (100.1 100.n) DE1 DEn (500.1 500.n)

SDout (500.1 500.n) DRAM (100.1 100.n) (500.1 500.n) DRAM (100.1 100.n) (500.1 500.n)

(300) (300) SDIn

(500.1 500.n) (300) MC가 (300) MC가 ("H" ) 가 (300) (500.1 500.n) 가 DRAM (100.1 100.n) , DRAM (100.1 100.n) (500.1 500.n)

MC가 (200.1 200.n) MC가 INV1 INVn (200.1 200.n) 가 (200.1 200.n) MC가 ("L" ) ( ) (200.1 200.n) , DRA (100.1 100.n) (500.1 500.n) (200.1 200.n) (10)

(300) (500.1 500.n) MCLK 가

CLK DRAM (100.1 100.n)

(400) (300) (400) CLK , (400) Add , DRAM Add

Add / P/F가 RD가

(300) 가 가

[DRAM 2 1 ] DRAM (100.1) DRAM (100.2 100.n) 가

2 , DRAM (100.1) (500.1) RAS, CAS, WE, MC (500.1) (200.1) A0 Ai(i: ) (32) ,

가 (32) (34) (36) (34) (36)

(30) (30) (30) ACT PCG (36)

READ, WRITE, UCCLK (34) RST

(300) UCCLK (34) RST

A0-9 /RA0-9 CA0-9 RA0-9 R

0-9 /CA0-9 /CA

DRAM (100.1) MC (110) WL (110)

MC GM( ) ( ) (110) WL (110)

WL GM( ) ( ) (110) WL (110)

R 2 WL (110) RMA , ( ) S

SR2가 ( ) SC 2 SC1 SC2가 SR 2 ( ) SR1

[DRAM DRAM ] (36) (32) (50) (52)

(40) (40R: ) (40R) (40S: SR ) 가

가 (50) (50R: ) (50R) (50S: SC )

(42) (40) (50S: )

(52) ( ) MC

BL, /BL (70) (60) (70) (72)

CLK Dout (500.1) Din (500.1) CLK

(82) (52) BL, /BL (80) (52)

[DRAM ] (36) (32) 가 (40),

UCCLK (34) (40), (200.1)

가 (50) (300) (82) DT (300)

가 DRAM (100.1) Exp.DT RMA (300)

(400) SR SC 가

(400) (400)

(40S) (50S) (300) 가

가 (40S), (50S) (50S) 가

(40S) (50S) (300)

가 (300) (400)

[ DRAM ] (32)

(40) (42) WL

가 (40S) SR WL (40R)

(50) (32) (32) 가

(50S) SC

(50R)

( BL, /BL ) (52) (52)

(300) (60) (70)

[ 3 1 ] (300)

(300) BIST (310) , BIST (310) (330)

(400) UCCLK DT (340) , BIST (

, BIST (310) (500.1) DRAM

310) (342) , (330) (330)

(342) (344) MC DE1 DEn( , DE<n> ) , (500.1

BIST 500.n) UCCLK가 , DRAM (100.1 100.n) (34)가

(34) (330) (330)가

(300) , Exp.DT BIST (310) DRAM (35)

(500.n) CLK Sout SDin , BIST (310) 가

0) , DRAM Exp.DT Sout / P/F (360) (350)

, (360) / P/F가 (400) , 가

Add가 (400) / P/F

DRAM Add , (300) MCLK CLK ,

TS (310) RST TE가 (310)

, (20) 가 ,

, (400) 가

[ 가 (400) ] (400)가

, (400) (400)가

4 1 DRAM 가 DRAM , DRAM (100.2)

,

4 DRAM (100.2) (34) , DRAM (100.2

) (140) 가 ,

4 가 ,

가





, 「RRC」 6 , 6 (400) Cb  
 , 「RRCC」 6 가 (400)  
 , 「RRCC」 7 , 7 (400)  
 00) , 「RRCC」 7 , 7 (400)  
 , 2 가 가  
 , 6가 가  
 「RRCC」 가 , 「RCCR」 가  
 1 (400) 2 가 가  
 6가 가  
 , 1 가 (1000) 가 DRAM 가  
 6a 6c (400) DRAM 가  
 , 「RRCC」, 「RCRC」 2 「CRRC」 3 1 3 6가  
 가 , 가 2 , 가 2 6가  
 6a 가 2 , 1 가  
 3가 , 3 가  
 가 가 (300) (400)  
 6b Ctl 가 1 , 2 가 가  
 「RCCR」, 「CCRR」 가 「CRCR」 3 가  
 6c 가 가  
 6c 「RCRC」 「CRCR」 , 2 가 가  
 가 가  
 [ (400) ] 가  
 7 (400) , 5 6a 6c 가  
 가 7 ARD 6가 , 6가  
 7 ARD 1 6 (400.1) 1 6 (400.6)  
 4100.1 4100.6) , 1 (4100.1) 6 (4100.6) 2  
 , 1 , , CM1 CM6 , 2  
 M1 2 , 1 , , (4100.1) , R  
 MCR11 , 2 RM1 CM1 1 Ra  
 , MCC11 , 2 Rb CM1 1 Ca MCR12  
 Cb MCC12

1 (4100.1) 1 MCR11, MCR12,  
MCC11, RM1 MCC12, CM1 P/F가  
MCR11, MCR12, MCC11, MCC12 CPR11, CPR12, CPC11, CPC12가  
CPR11 CPC12 MCR11 MCC12  
ML PCG "H"  
MCR11 MCR12 RA0, /RA0 (組) RA9, /RA9 10  
(CAM : Content Addressable Memory Cel  
l) 가 MCC11 MCC12 CA0, /CA0 CA9, /CA9  
10 RM1 CM1 CAM 1 (4100.1)  
TWL ("H" )  
"H" ML  
ARD RA0, /RA0 RA9, /RA9  
CA0, /CA0 CA9, /CA9 "H"  
ML "L"  
가 MCR11, MCR12, MCC11 MCC12 SFR11, SFR12, SFC11, SFC12  
SFR11 SFC12 RST  
TWL ("H")가  
2 (4100.2) 2 RM2 CM2가  
2 (4100.2) RM2 CM2  
가 MCR21, MCC21, MCR22, MCC22, / P/F  
3 1 (3100.1) 가 3 6 가  
6 (4100.3 4100.6) 가 (4100.1) 가  
(4100.1) 가 1 (4100.1) MCR11,  
MCR12, MCC11 MCC12 P/F가 ML "H" "L" (4100  
.1) MCR11 TWL MCR11 MCR11  
SFR11 / P/F가 가 MCR11 CAM  
MCR11 ML (3100.1) 가  
MCR11 MCR12 가  
R12 가 MCR11 1 (4100.1) 2 MC  
TWL MCR12  
, 2 MCR12 SFR12 가 가  
가 MCR12 가  
가 1 (4100.1) 1  
가 1 (4100.1)  
가 MR1 CM1  
, 1 (4100.1)

가 RF1 , , ARD  
 (300) , 1 (4100.1) RM1  
 CM1 , 2 가 (4100.2) 2 (4100.2) 6 (4100.6) 2 6  
 , 1 (4100.1) 6 (4100.6) (100R) RF1 RF6 가가 ,  
 ("L" ) 가  
 (300)  
 OS) 가 (50S) , (4  
 8 7 MCR11 MCR12 CAM  
 CAM ) RA9( 가  
 , BSE TA1 , n1 CBL1 , INV1 RAi CAi, i:  
 /RAi TA1 , n1 CBL1 TWL INV2 BSE  
 n2 /CBL21 /CAi) TWL /RA9( N  
 TA2 , ML T11 T12 ,  
 MHL T11 CBL1 T13 T14 T11 T12 ,  
 n2 T13 BSE n1 , T14  
 /CBL1 TWL , BSE CBL1 /CBL1  
 , BSE ML , T11 T12 CBL1 /CBL1 가 ,  
 T13 T14  
 9 7 8 (CAM )  
 9 7 CAM MCR11 MCR12  
 , 9 MCR11 , B1  
 t1 CLK , (300)  
 , A1 P/F가  
 P/F t1 A1 "H" 가 ,  
 , PCG가 "H" , MCR11 ML "H"  
 PCG A1 , B1 ,  
 , MCR12 , TWL "H" , ML "L" A1  
 , t2 CLK , TWL 가 ,  
 (300) B1 (400)  
 , PCG가 "H" , MCR11 P/F "H"  
 , (300) MCR11 B1 ML "H"  
 MCR11 B1 ML MCR11 PC  
 G가 "L" , "H"  
 , B1 가 가  
 , R R C C , 가 가

10 1 CAM 가 (400) ( 2 2 ) 가 가 (400) (300) CLK (4010) ( , CAM : 4000) , Ctl (4010) , (4000) TRAIin , CAM (300) (4000) , CAM (4000) TRAout (4010) + (4000) +S/A : 4020) , (300) (4000) CAM TCAout (4000) TCain , CAM (300) 가 CAM TCAout (4000) , CAM +S/A (4030) , 가 (4000) , (4100.1 4100.6) (4010) 가 가 (4100.1 4100.6) (300) P/F CAM (4000) (300) 가 가 (4100.1 4100.6) RF1 RF6( , ) 가 가 2 , 2 가 (40 0) , 10 RF ) , DRAM 가 가 가 [DRAM (400)가 가 , DRAM 가 (4020 4030) 11 10 CAM (4000) +S/A (4020 4030) 7 CAM (4000) (CAM ) RM , (CAM ) CM RM 12 RM RA<0> RA<9>가 가 , CM 12 CM CA<0> CA<9>가 , 11 , RA<0> RA<0> /RA<0>가, 2 CAM RM TWL(0) TWL(11) , ML(0) ML(11) CAM CM , 가 , TWL(0) TWL(11) ML(0) ML(11) , TWL(0) TWL(11) TWL 11 CAM (4000) DRAM (100.1 100.n) , ML DRAM DRAM , DRAM (100.2) CAM (4000) RA<0> RA<6> , 가 DRAM 가 CA<0> CA<3> 가 CAM (4000) ,

ML(0) ML(11) ( ) CAM  
 RA<7> RA<9> RA<0> RA<6> 가 .  
 CAM ML(0) ML(11) , CAM RM 가  
 RA<0> RA<6> RA<7> RA<9> 가  
 +S/A (4020) RA<0> RA<6>  
 (300) (4010)  
 RA<7> RA<9> (300) 가  
 +S/A (4020) (300)  
 RA<0> RA<6> / (4020F)  
 (4010) / (4020V)  
 가 +S/A (4030) (300)  
 CA<0> CA<3> / (4030F)  
 (4010) / (4030V)  
 12 11 +S/A (4020) / (4020V) , C  
 AM (4000) CBL1, /CBL1 CAM  
 12 IBF1 RA<i> n11  
 n11 n12 N MOS TR411 n11  
 TR411 (4010) MOS TR412 TR411 LT41 n11  
 TR412 LS TR412 LT41 TR412  
 IBF1 INV411 , INV411  
 TR411 INV412 TR413 TR413 INV411  
 n12 TR413  
 n12 CBL1 TR414가 TR414  
 (4010) CBL1 TR414  
 IBF2 RA<i> /RA<i> CWE  
 n21 n21 n22 N MOS TR421 TR421 L  
 n21 TR421 (4010) MOS TR422 TR422  
 T42가 TR422 IBF2 INV421 , INV  
 LT42 TR421 TR421 INV422  
 421 n22 TR423 TR423 INV421  
 n22 /CBL1 N MOS TR424가 TR424  
 (4010) /CBL1 CWE  
 S/A CBL1, /CBL1 TRAout i  
 TRAout<i> (4020V) 가 , /  
 (4030V) 가  
 LS LT41 LT42 , CAM (4000)  
 13 CBL2, /CBL2 (4020F)  
 IBF3 RA<j> N MOS TR434 CBL2  
 가 , IBF4 , RA<j> /RA<j> ,  
 TR444 /CBL2  
 TR434 TR444 CWE TRAout j T  
 S/A CBL2, /CBL2 TRAout j T  
 RAout<j> 12

(300) Ctl +S/A (4020)  
 (4010) LS가 가 .  
 (4010) , CBL1 /CBL1 "H"  
 RA<i> /RA<i> IBF1, IBF2 LT41 LT42 .  
 LT41 LT42가 TR411 TR421 가  
 TR413 TR423 가 .  
 IBF1 TR411 n12 , C  
 WE가 ("H" )가 CBL1 .  
 +S/A (4020) RA<i> /RA<i> "L" (40  
 10)가 LS "H" , TR411 TR421 LT41 LT42  
 "L" TR413 TR423 가 .  
 IBF1 IBF2  
 CWE가 ("H" )가 "L" "H"  
 [ ]  
 14 10 (4100.1) .  
 14 1 (4100.1) .  
 2 가 (4100.2) 6 (4100.6) , .  
 1 (4100.1) MCR11 ML SFR11  
 AND (4102) , MCR12 ML , SFR12  
 AND (4104) , MCC11 ML , SFC11  
 AND (4106) , MCC12 ML , SFC12  
 AND (4108) , AND (4102 4108) , MS 4 NOR ( 4110)  
 1 (4100.1) AND (4102 4108) , ML  
 MHa, MHb, MHc, Mhd , SFR11 SFC12  
 MVa, MVb, MVc, MVd .  
 1 (4100.1) , MVa , MVb , MVc  
 , MVd , MS , / P/F , (4200) , MVa  
 MCR11 , TWL , WEa , (4202) , MVa , MVd , TWL ,  
 MS , / P/F , , MVc , MCR12 , TWL , M  
 Vc , WEb , (4202) , MVa , MVb , , M  
 MVd , MS , / P/F , , (4204) ,  
 MVa , MVb , MVc , MVd ,  
 MS , / P/F , , MCC12 , TWL  
 WEd (4206) .  
 1 (4100.1) , MVa , MVb , MVc , MVd ,  
 MS / P/F , WEe 6 AND (4208) , URF  
 (4010) URNS URN<0:4> , WEa WEe URF  
 SEL1 , RST URF 1  
 RF1 FF1 .  
 15 14 SEL1 .  
 15 SEL1 WEa n451 , FF1 URF  
 n456 , N MOS TR451 , WEb n452 , n456  
 N MOS TR452 , WEc n453 , n456  
 MOS TR453 , WEd n454 , n456 N  
 TR454 , WEe n455 n456 N MOS  
 TR455 , TR451 TR455 , (4010) URF  
 S CLK , (4010) URN<0> URN<4>  
 1 TR455 LT451 LT454 . LT451 LT454 TR45  
 URGS<0> URGS<4> .  
 (4010) URN<0> URN<4> , 6a 6c  
 가 가 가 (4100.1) .

TR455 URSG<4>가 URGS<0> URGS<3>가  
 가 「RRCC」 가  
 WEe URF FF1  
 URGS<3>가 URGS<0> URGS<2> URGS<4>가  
 TR454 WEd URF FF1  
 「RRC」 가 가 FF1  
 16 15 LT451 가 LT451 LT452 LT45  
 5 LT451 URNS CLK NAND NAD1 NAND NAD1  
 URN<0> n461 n462 n462 TR461  
 n462 URGS<0> INV461 INV461  
 n462 INV462  
 17 15 SEL1 (4010)  
 t1 CLK (4010) URNS가  
 "H" (4010) URN<0:4>( URN<0> URN<4> URN  
 <0:4> ) "00010" URGS <0:4>( URGS<0> URGS<4>  
 LT451 LT455 URGS <0:4>( URGS<0> URGS<4>  
 URGS<0:4> ) "00010" 「RRC」 가  
 TR454 가  
 FF1 (4100.2 4100.6) 가  
 18 1 (500.1) 가  
 (500.2 500.n) 가  
 (200.1) DRAM (100.1) (510.1 510.k)(k: )  
 , DRAM (100.1) (200.1) (520.1  
 520.m)(m: ) (520.1 510.k 520.1 520.m) (300)  
 (510.1 510.k 520.1 520.m) (300)  
 (500.2) (510.1) DE1, CLK MC  
 (100.1) UI (300) CI DRAM (100.1)  
 Sin  
 (510.1) CI DRAM (100.1)  
 (520.1) DE1, CLK MC DRAM (100.1)  
 CO UO (200.1) DR  
 AM (100.1) Sout  
 (520.1) Sout (500.1 500.n)  
 (300) SDin (520.2 520.m) 가  
 19 18 (510.1) (510.2 510.k)  
 가 Sin (300) (100.1)  
 (510.1) UI MC (512) TR51  
 (512) CI DE1  
 0 Sout CLK D (514)  
 20 18 (520.1) (520.2 510.m)  
 가 MC (522) (522) D  
 RAM (520.1) CO (522) DE1  
 TR520 (100.1) Sin (522)  
 DE1 INV520 TR522 (5  
 22) CLK Sout D  
 (524) MC TR520  
 (522) UO MC (522)



DE1 ("H" ) TR520 D (524)  
 , DE1 ("L" ) TR522 D (524)  
 (500.1 500.n) , (300) DRAM  
 [ (300)/ (400) ]  
 21 22 (300) (400)  
 , 21 (300) DRAM , DRAM  
 (100.1) (330)  
 , (342) ( S100).  
 , (300) (400) +S/A (420)  
 430) 가 (4100.1 4100.6) ( S102).  
 (400) +S/A (420 430) LT41 LT42  
 SEL1 LT451 LT455 ( S104).  
 , (300) (500.1 500.n)  
 ( S106). , DRAM (100.1)  
 (34) ( S108). (300) , (330)  
 ( S110). ( S112),  
 , DRAM (100.1)  
 , (300) (330) DRAM (100.1) (  
 34) RST (300) (500.1 500.n)  
 , (300) DRAM (100.1) ( S114). DRAM (100.1)  
 , (34) ( S116). (300)  
 , (330) ( S118).  
 360) 가 , 가 P/F (300) (400) (  
 S120). (400) CAM (4000)  
 가 ( S122). ( S124), CAM  
 (4000) ( S132).  
 가 ( ) ( ) 가 (4100.1 4100.6) , ( S12  
 8), 가 CAM (4000) ( S130).  
 , 가 ( S124), CAM (4000)  
 ( S132). ( S140), S114  
 S140 DRAM  
 22 , (400) (300)  
 가 ( S42). (400) (300)  
 가 ( S144). RDC가 ,  
 가 Dout (22) ( S146).  
 , DRAM (100.1) 가 ( S148).  
 , DRAM (100.2 100.n) 가 ( S150). , DRA  
 M 가  
 [ (34) (330) ]  
 23 2 (34) (34) , 2 . 23  
 , 2 . 2  
 2 UCCLK , 1 A<0> A<N-1>

23                    tb                    UCCLK                    , N                    가                    ,  
                   A<0> A<N-1>  
 24                    3                    (300)                    (330)                    (344)  
                   (342)  
 24                    (330)                    DRAM                    (100.1 100.n)  
                   2                    (3302)                    , 2                    (3302) 12 2  
                   (3404) 2                    (3302)                    A<0> A<11>  
                   (3304.0 3304.11) ,                    (3304.0 3304.11)                    (342)  
                   (3306) ,                    (3306)                    (3304.0 3304.11)  
                   (3302) BIST                    (310)                    (3302)                    (3308)  
                   (34) 2                    UCCLK  
 25                    24                    (330)                    UCCLK  
 1>                    t0                    UCCLK                    , 2                    (3302)                    A<0> A<1  
                   A<0>가 "H"                    (3304.0)                    MC<0> "H"  
                   ,                    t1                    UCCLK 2                    ,                    A<1>가 "H"  
                   (3304.1)                    MC<1>가 "H"  
                   (3304.0)                    MC<0> "L"  
                   ,                    가                    (342)                    ,                    A<0> A<11>  
                   ,                    MC<0> MC<11>  
                   t3                    UCCLK                    ,                    A<0>가                    가                    ,  
                   MC<0>가 "H"                    (3304.0 3304.11)                    "H"                    ,  
                   (3306)                    "H"  
                   t4                    UCCLK                    (3306)                    "H"  
                   (3308)                    가 "H"  
                   , 2                    (3302)                    ,                    A<0> A<11>가                    "L"  
                   25                    12                    (342)  
                   "1"                    ,                    A<0> A<11>가                    "L"                    ,                    MC<0> MC<11> "L"  
                   "                    ,                    (3306)                    (3306)                    "L"  
                   t6                    (3306)                    "L"                    ,                    (3308)                    "L"  
                   UCCLK                    , 2                    (3302)  
                   (300)                    (330) , DRAM                    (100.  
 1 100.n)                    (34)가                    (500.1 500.n)  
                   (300)                    DRAM                    (100.1 100.n)  
                   (34)가                    (500.1 500.n)                    가  
                   ,                    , DRAM                    (100.1 100.n)  
                   , DRAM                    (100.1 100.n)  
                   (300)                    (500.1 500.n)  
 [ 2 ]  
 26                    2                    (2000)  
 1                    1                    (1000)                    ,                    (300)  
                   (400)                    가                    ,                    TTE  
                   (300) 1                    (200)  
                   ,                    DRAM                    (100)                    1                    (200)  
                   (2000)                    (200)  
                   (200)  
                   ,                    (210 220)가  
                   26                    DRAM                    (100)                    (200)가                    (2000)  
                   (2000)                    ,                    DRA

M (100)가 , DRAM (100) , (200) (200)가 (210) , (112.1 112.n)

26 (114) , (114) (112.1 112.n) (112.1 112.n)

n) , ABS , (114) (112.1 112.n)

CBS , (114) (112.1 112.n)

DBS

DRAM (100) , (300) DE1 DEn , (116.1 116.n)

(116.1 116.n) , (118.1 118.n) , (118.1 118.n)

CBS (112.1 112.n)

(120.1 120.n)

(200) , DRAM (100) 가 (210) (210) , (200)

가 (220) , (200) , (10) (200)

가 (220) (10) (200) (25) , 가 ,

(220) , (26)가 , (200) 가 ,

(25) (220) (26) (220) , (220) 가 (2

20) , 26 , (112.1 112.n) 2 (40), (72,

(42), (50), (52), (70), (80), (72,

82)

27 26 , DRAM (114)

26 (300) , (300)

(2000) )가 , 가 (300)

(2000) 「 가 」 ,

DRAM DRAM (100) , 가 , 가

SRAM , (112.1 112.n) 가 (

, ACT )가 , ( , ACT )가 , (112.1 112.n) 가 (

(120.1 120.n) , 가 .

가 , 가

27 , (200) ACT, P

RE, READ, WRITE , (114)

(112.1) 가 (112.1)

(1142.1) , 가 (1144.1)

, ( : 1144.1) ,

가 (1146)

(1146) (1148.

1) , AND (1150.11 1150.14) (1152.11 1152.14)

AND (1150.11 1150.14) TTE가 ,

(1146) (1142.1)

(1152.11 1152.14) CBS , (300)

(112.1) , (1154.1)

148.1) , (1156.1) , (1154.1) (1

1) , ABS (1154.

(1154.1) (34) , 가

가 .  
 (112.2 112.n)  
 DBS (1162) , (112.1 112.n) WDQ MC  
 (1146) (200) (116)  
 0) 가 , 가  
 (1146) (300) , 가  
 가 (112.1 112.n) (1146) (1152.11)  
 TTE "L" (1146) (1152.11 1152.14)  
 1152.14) , (112.1 112.n)가  
 CBS , TTE "H" , (1152.11 1152.14)  
 가 , 가 DEi(i=1 n)가  
 (116.1 116.n) , (116.1 116.n), (118.1 118.n), (120.1  
 (112.1 112.n) (118.1 118.n) /  
 (116.1 116.n) (114) (200)  
 IL1 ILn , (300) DE1 DEn  
 , (116.1 116.n) (118.1 118.n)  
 , (118.1 118.n) (120.1 120.n)  
 (114) (1146) ,  
 29 26 28 가 (2000) , DRAM (100)  
 TTE "L" t1 t2 , ,  
 , t2 t3 , TE "H" ,  
 , t3 t4 , i  
 , t4 t5 TE "H" ,  
 , , 2 (114)  
 (112.1 112.n) , (114)  
 가 , TTE  
 (300)  
 DRAM (100) , 가 ,  
 0) , (112.1 112.n) , (116)  
 , (300) 가 가 ,  
 TE t5 t6 , ,  
 t6 , t6 t7 , TTE "H" , 2 , 2  
 , DRAM (100) , TTE 2 , 2  
 (1146) (300) DRAM (100) CAS 가 2  
 , TTE ,

t7 RDQ  
 (1146) , 1 가 ,  
 [ 3 ]  
 30 1 (1000) 2 (2000)  
 (400) CAM (4000)  
 30 CBL1, /CBL1 CBLm, /CBLm CBL'1, /CBL'1 CBL'm, /CB'  
 Lm ( ) ( ) 2  
 (+S/A: 4020 4030) (4100.11  
 4100.12) 30 (4100.11 4100.12)  
 1 2 (4100.1 4100.6) 1 2 가  
 CAM 1  
 30 (4020 4030)  
 , CAM (400) 가  
 31 30 CAM  
 CAM 가 CAM 가  
 32 31 CAM PA  
 1 2 , 1 2  
 CAM CAM  
 CBL, /CBL  
 33 CAM (4000)  
 33 , CAM  
 30 가  
 33 TWLR1 TWLRn TWLC1 TWLCn, MLR  
 1 MLRn MLC1 MLCn 2 ,  
 (4020 4030)가  
 CAM  
 , CAM 가  
 34 33 CAM  
 CAM 가 CAM  
 가  
 35 34 CAM CAM MC'n1( 34 PB1)  
 1  
 2  
 , WL ML  
 36 34 CAM CAM CAM  
 CAM CAM 35 , 36  
 CAM  
 CAM  
 37 CAM CAM  
 CAM CAM CAM  
 (4100.13) CAM CAM  
 ML1 MLn CAM CA  
 ML1' MLn'

, CAM , CAM , CAM (4000) , CAM  
 , CAM 30 , CAM  
 CAM 37 CAM 가  
 38 CAM 37 CAM CAM  
 CAM BSE , BSE n1 CBL1 , CBL1 INV1 INV2  
 N /CBL1 , TA1 , n2 /CBL21 T  
 WL N BSE n2 TA2 , 1 ML1  
 CAM , 2 T111 T121 , 1 ML1  
 T131 T141 N T112 T122  
 , 2 ML2 T132 T142 BSE T1  
 22 T111 CBL1 T121 CBL1 BSE T1  
 n2 T112 T121 CBL1  
 BSE n2 T141  
 T131 BSE n1 BSE T141 n1  
 /CBL1 T132 /CBL1 CAM , C  
 T142 CAM CAM  
 AM , CAM CAM  
 39 CAM CAM 2  
 39 CAM (4020) (4100.14) 1  
 , 2 CAM  
 CAM 가 CAM  
 CAM CAM  
 [ 4 ]  
 40 CAM 가 ( S202).  
 ( S204) , CAM ( S206).  
 CAM ( S208), 가 , CAM  
 S210). 가 ( S208), 가 CAM ( S212).  
 ( S214).  
 CAM  
 ( S216).  
 가  
 S220), (400) CAM ( S218), ( S220), ( S224), ( S220),

( S222)  
CAM

[ 5 ] 1 4 CAM CBL1 /CBL1

5 12 13  
가  
41 11 1 +S/A (4020) / (4020V) , CAM (4000) CBL1, /CBL1 CAM

41 IBF1 RA<i> IBF1  
n11 N MOS TR502가 n11 n12  
N MOS TR504가 TR504 (4010)  
CWE n12 CBL1  
INV504 n12 INV504  
n21 N MOS TR512가 n21 /CBL1  
N MOS TR514가 TR514 CWE  
RG502 (4010) CBL1 /CBL1  
"H" "L"

n11 TR510 TR510 RG50  
2 n11 n21 TR502 TR512  
INV502 S/A  
41 12 가  
/ (4030V) (4020V) 가 /  
RG502 CBL1 /CBL1 "  
L" 8 CAM T11 T  
14가 가 , CAM  
"H" , CAM

42 11 / (4020F) , CAM (4000)  
CBL2, /CBL2  
41  
42 IBF3 RA<i> IBF  
n31 N MOS TR524가 TR524  
CWE n31 CBL2  
INV524 n31 INV524  
/CBL2 N MOS TR534가 TR534  
CWE 12 13 가  
DRAM  
가 가

가

(57)

1.

(100.1 100.n) ,

(SR) (SC) (RMA) ,

(300) ,

(400)

(400)

(4000) ,

(4020, 4030) ,

(4100.1 4100.6) ,

2.

1 ,

3.

2 ,

(4100.1 4

100.6) ,

(4200 4208, FF1) ,

(SEL1)



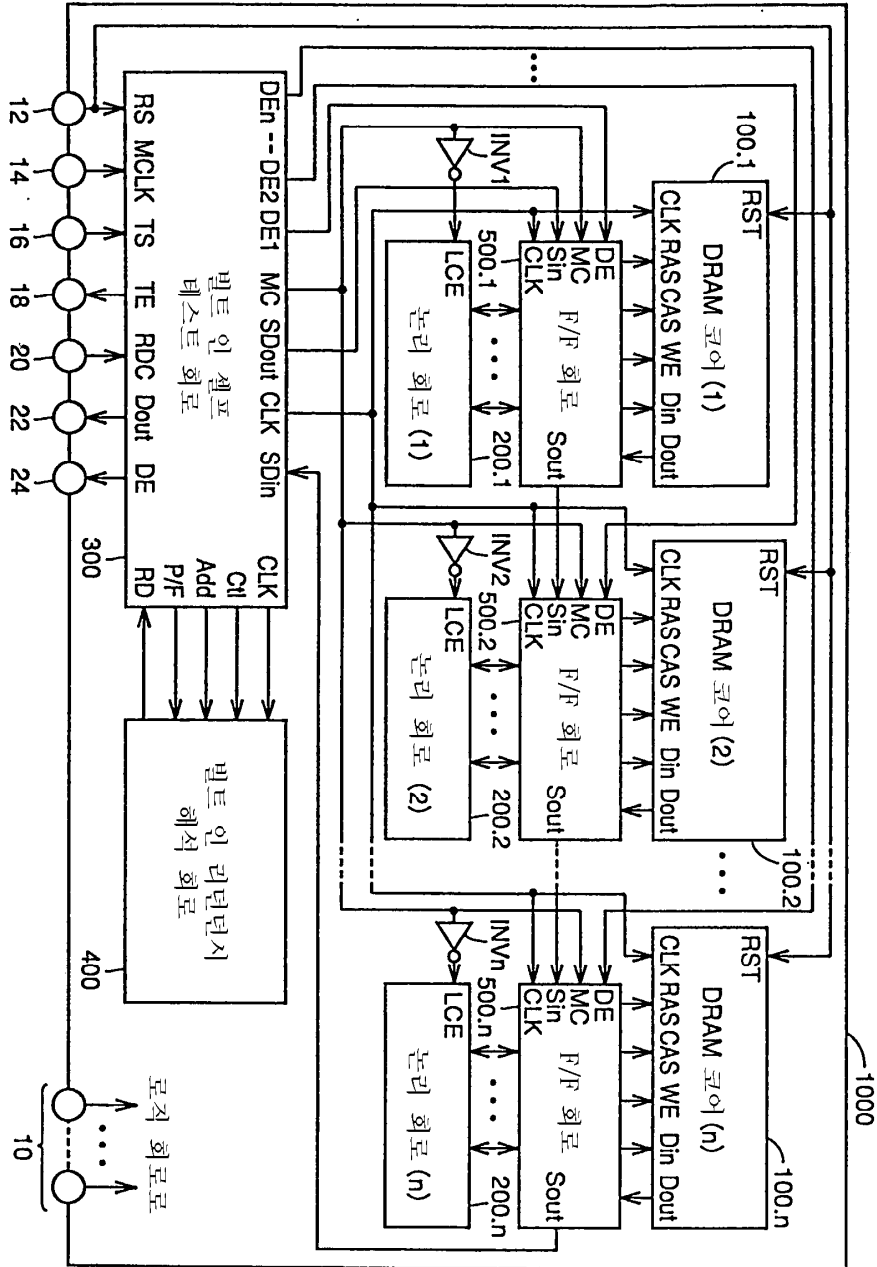

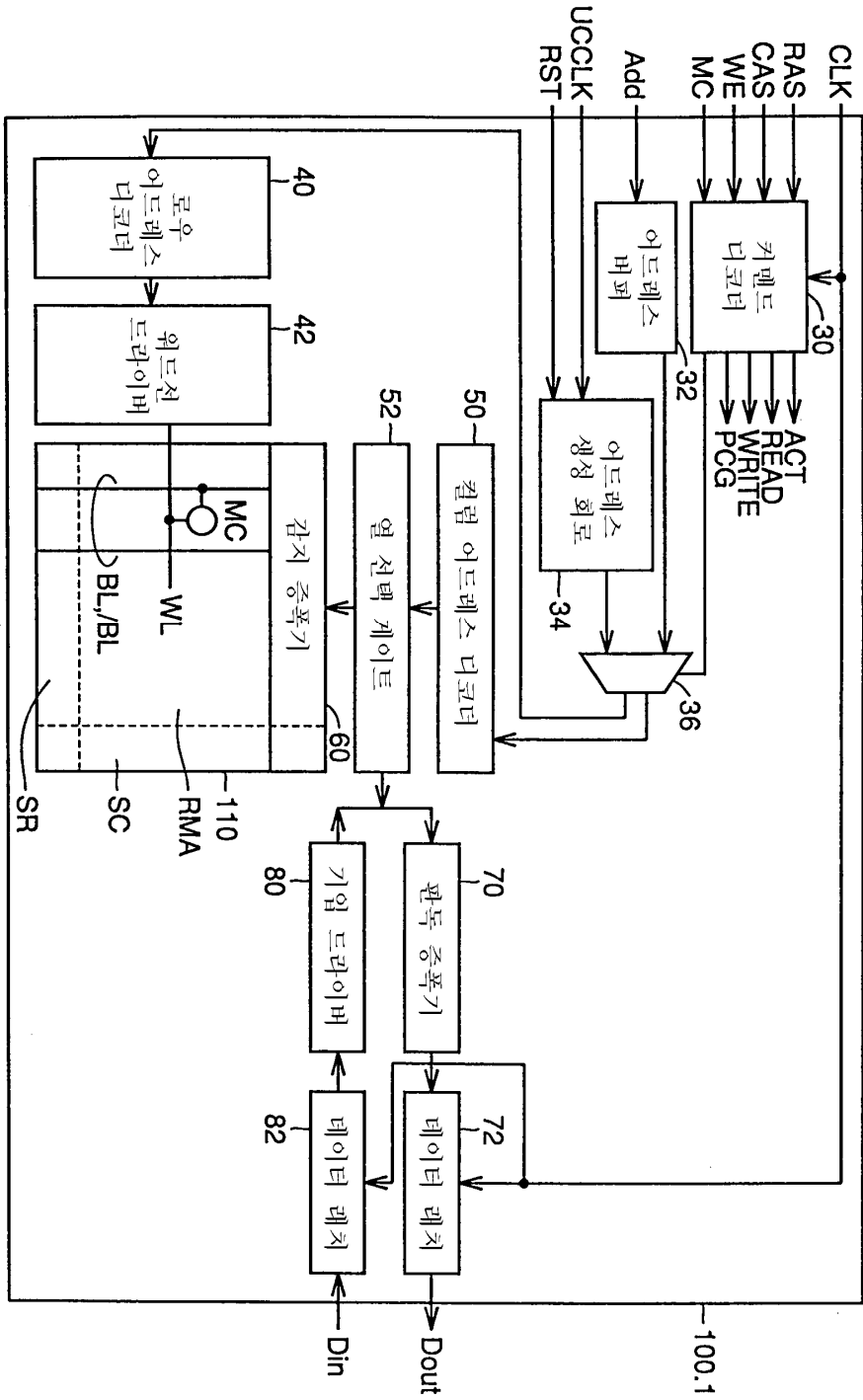

3

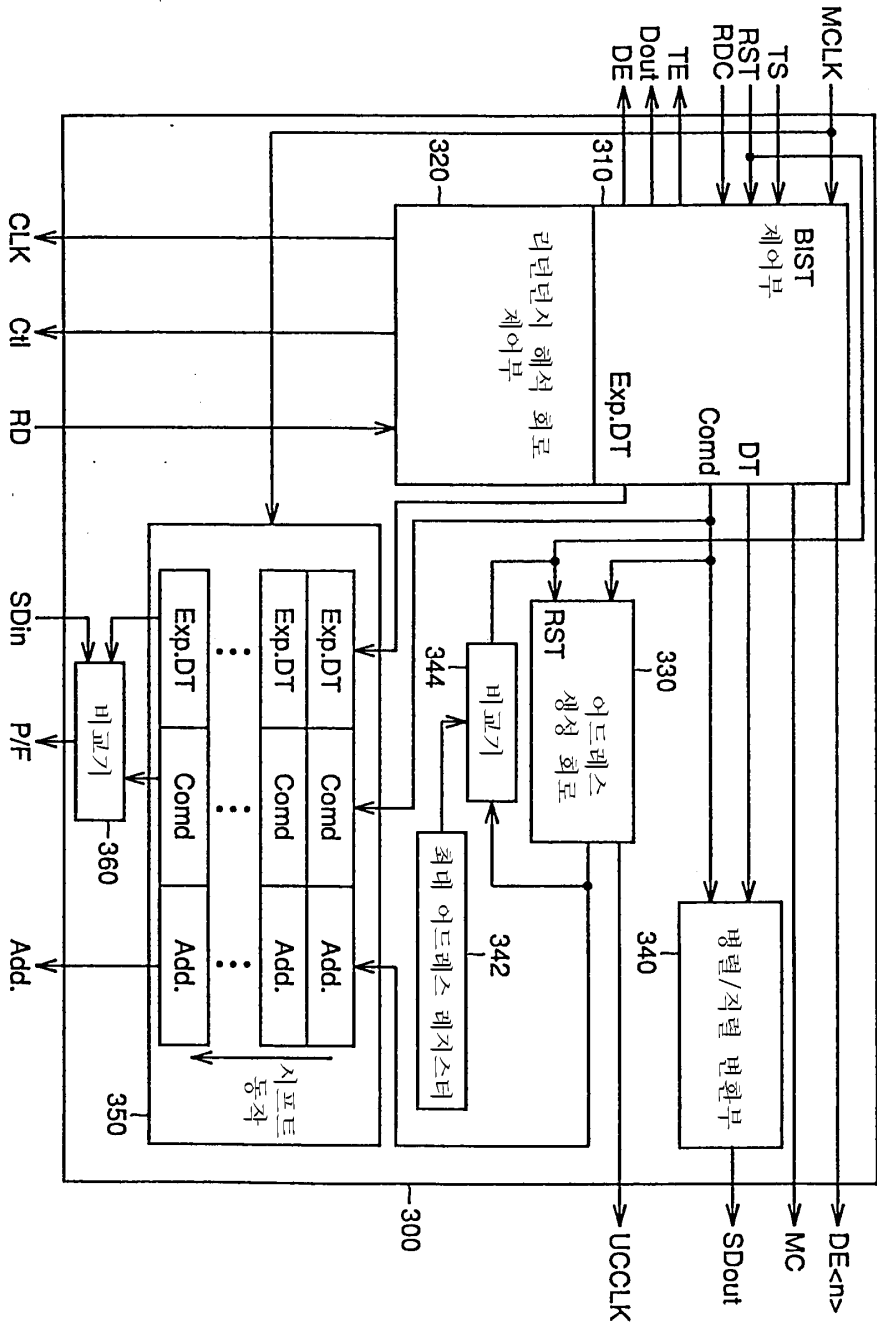

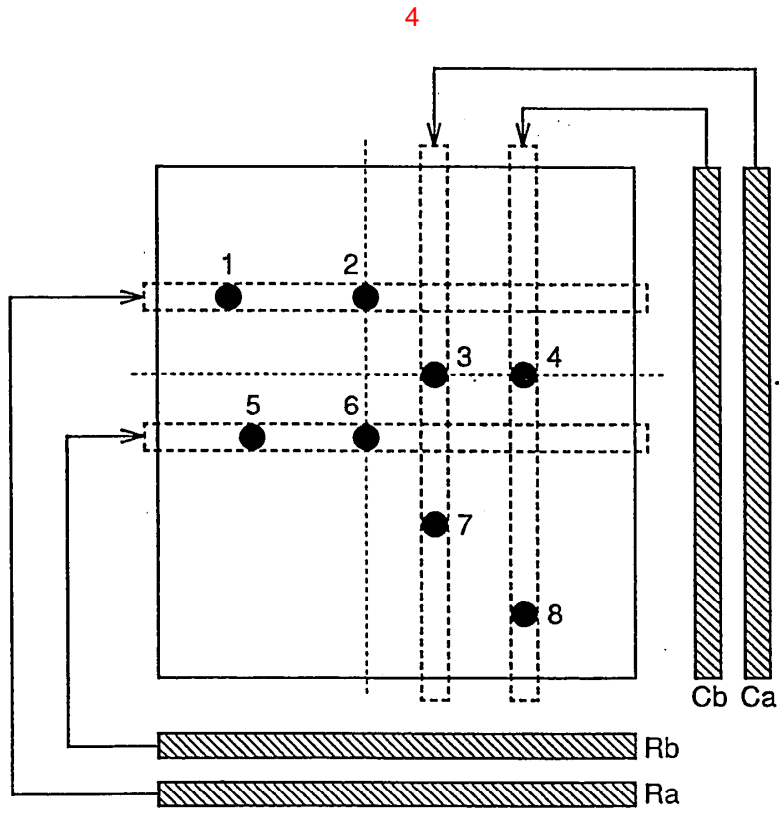

5

구체 예	결함 비트								판정
	1	2	3	4	5	6	7	8	
RRCC	Ra	Ra	Rb	Rb	Ca	Cb	X	-	N.G.
RCRC	Ra	Ra	Ca	Rb	Cb	X	-	-	N.G.
RCRR	Ra	Ra	Ca	Cb	Rb	Rb	Ca	Cb	O.K.
CCRR	Ca	Cb	Ra	Ra	Rb	Rb	X	-	N.G.
CRCR	Ca	Ra	Cb	Rb	X	-	-	-	N.G.
CRRC	Ca	Ra	Rb	Rb	Cb	X	-	-	N.G.

6a

스페어 로우: 2개 스페어 컬럼 1개

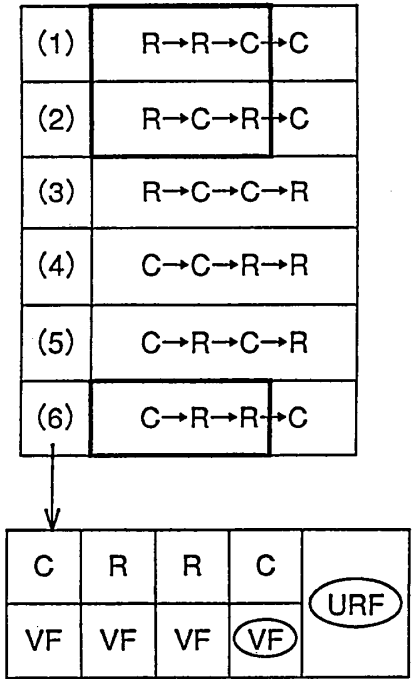

6b

스페어 로우: 1개 스페어 컬럼 2개

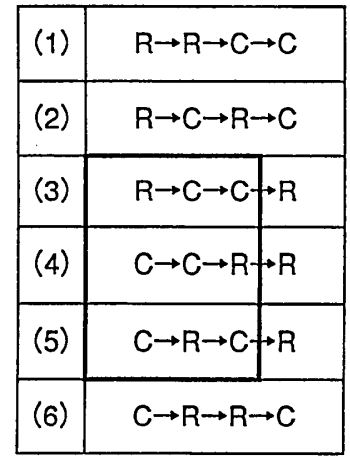

6c

스페이스 로우: 1개 스페이스 컬럼 1개

(1)	R→R→C→C
(2)	R→C→R→C
(3)	R→C→C→R
(4)	C→C→R→R
(5)	C→R→C→R
(6)	C→R→R→C





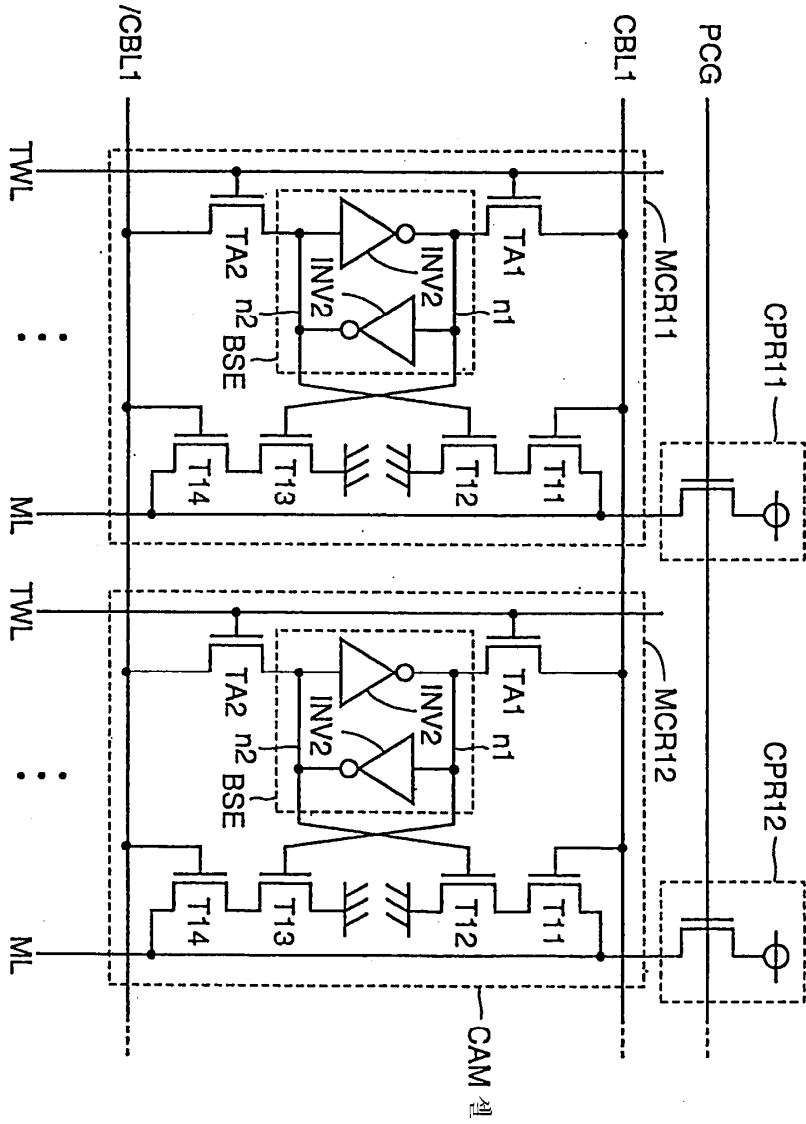

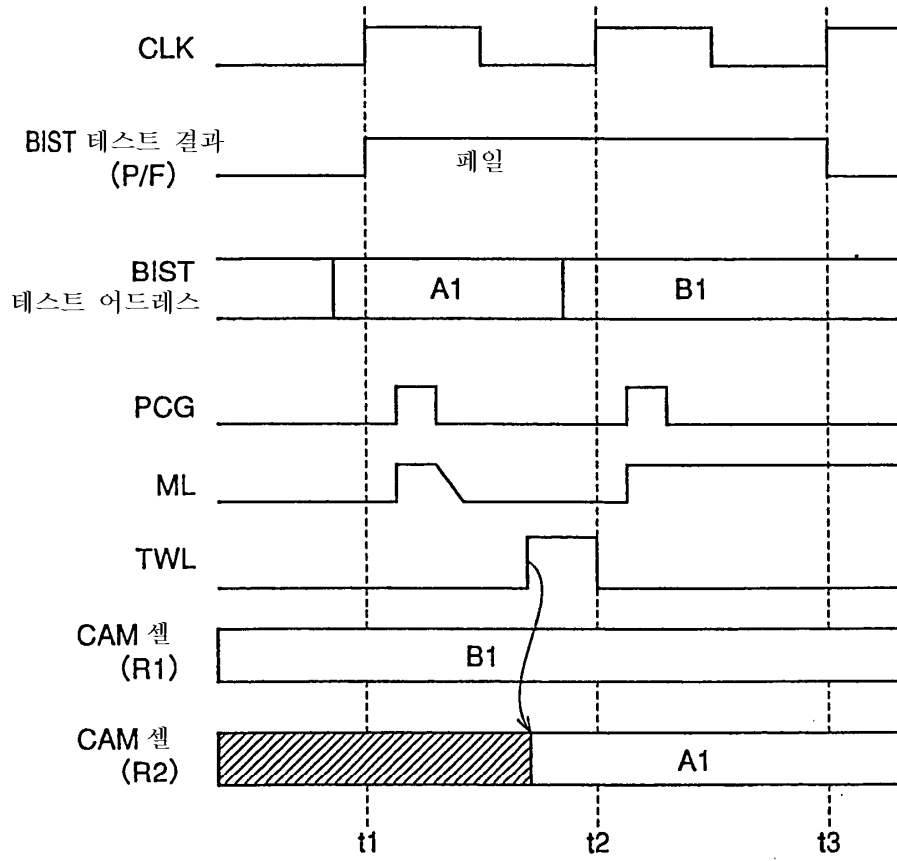

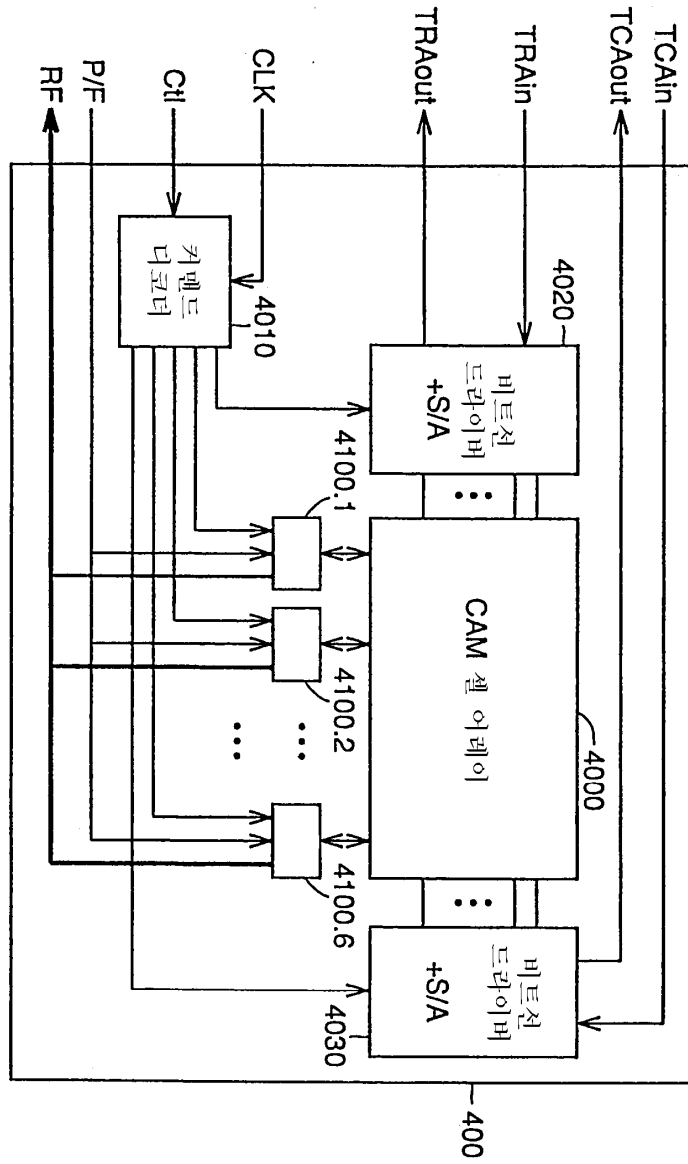

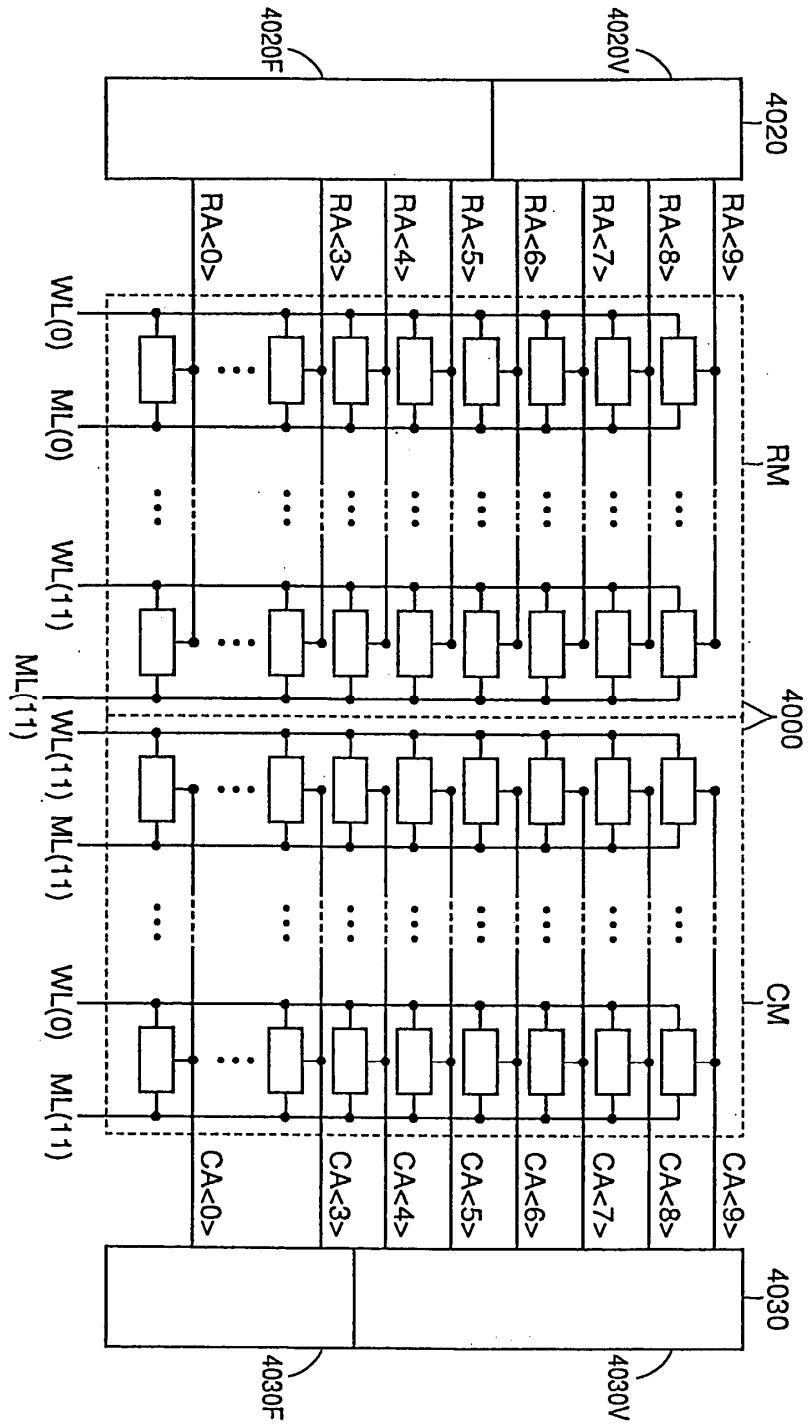

12

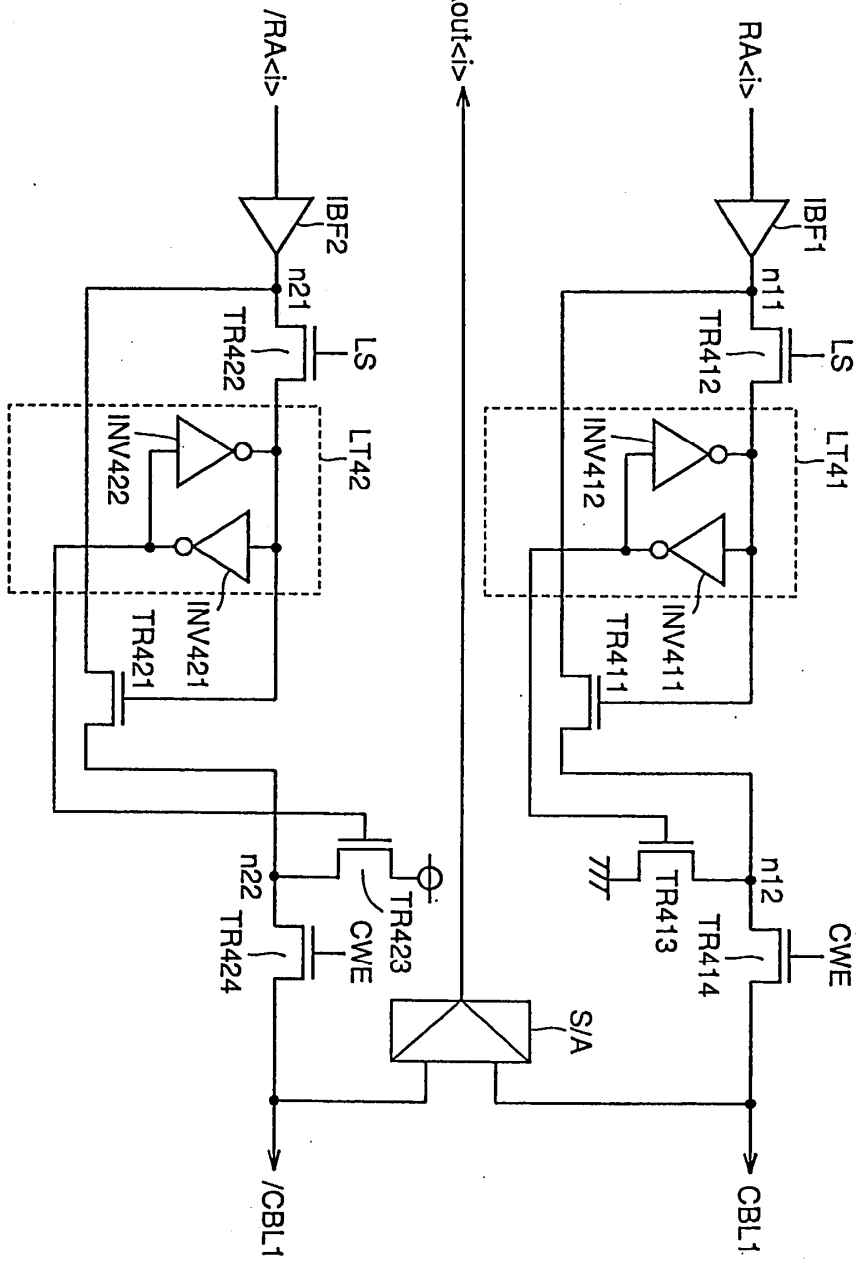

13

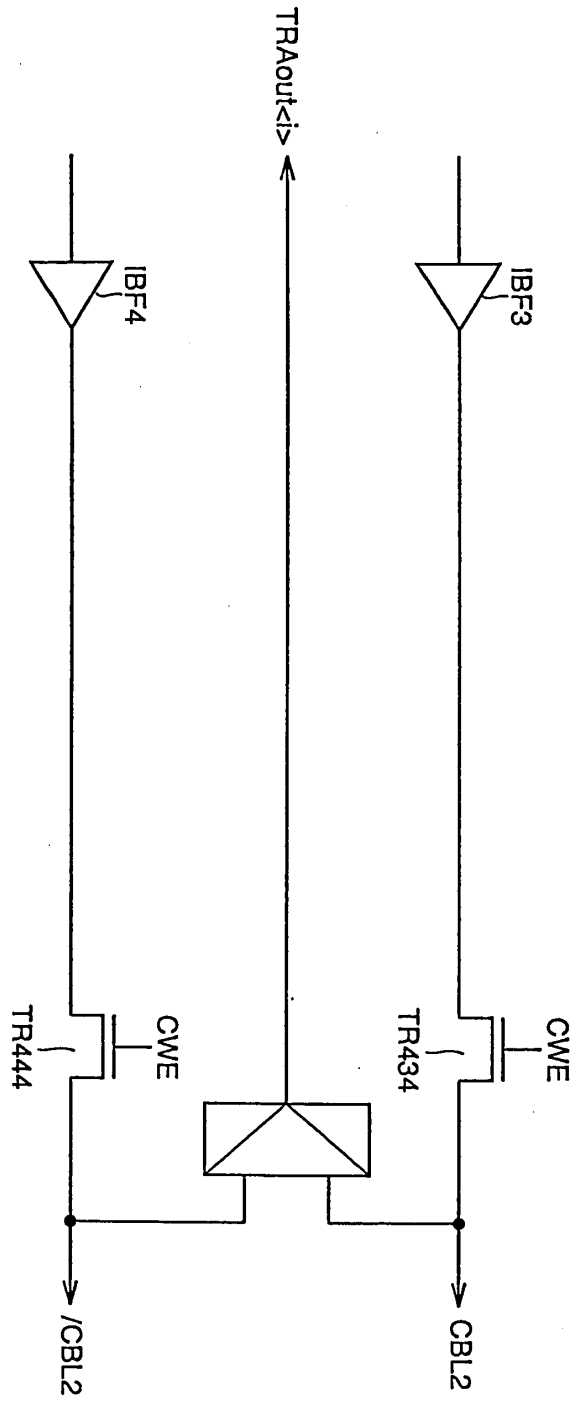

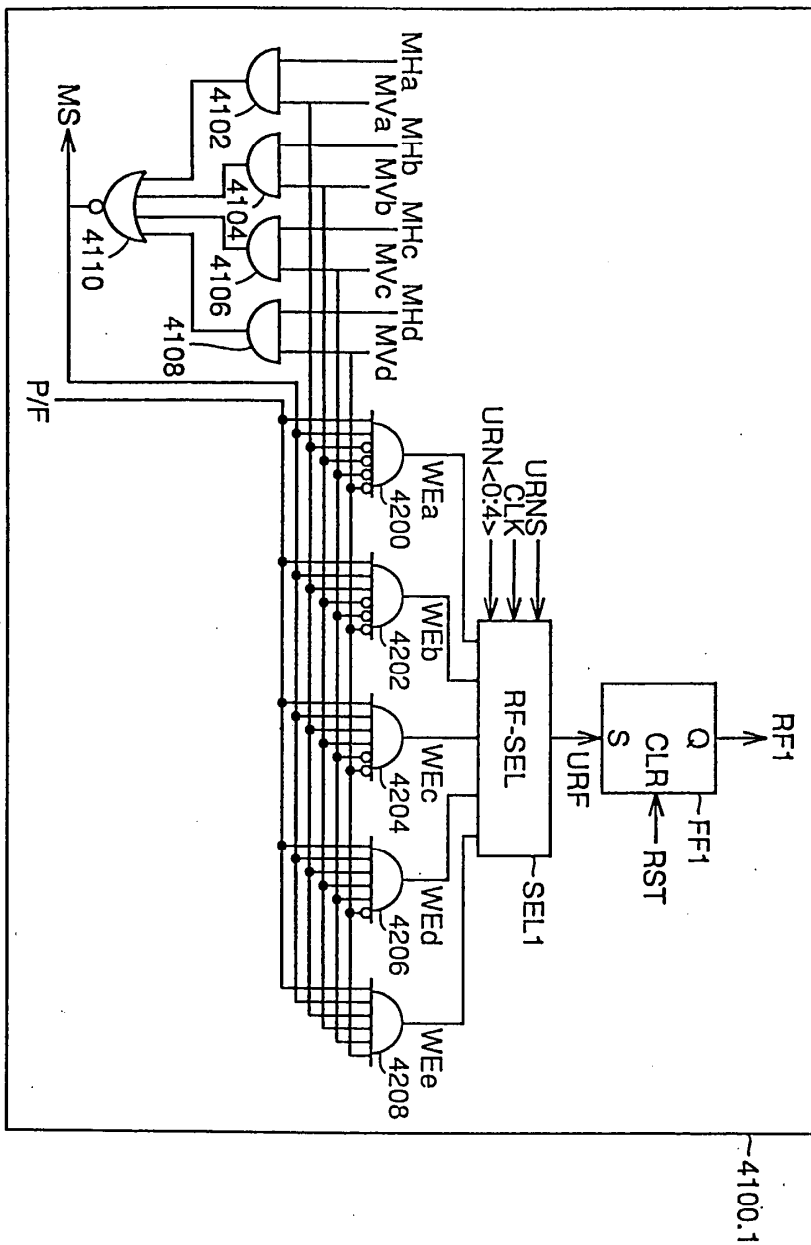

15

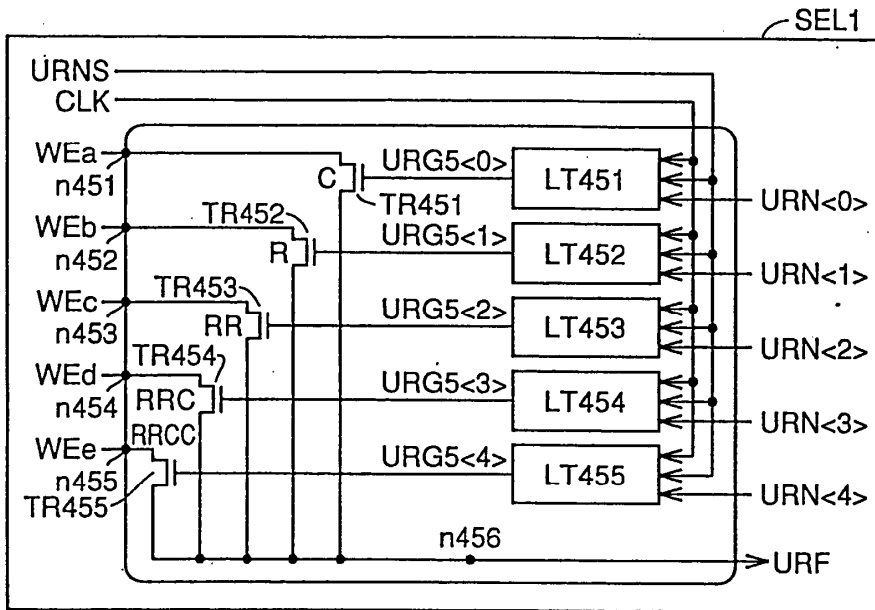

16

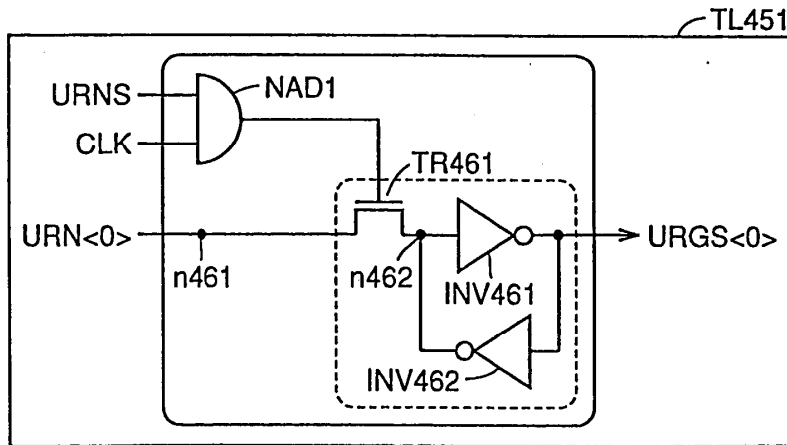



17

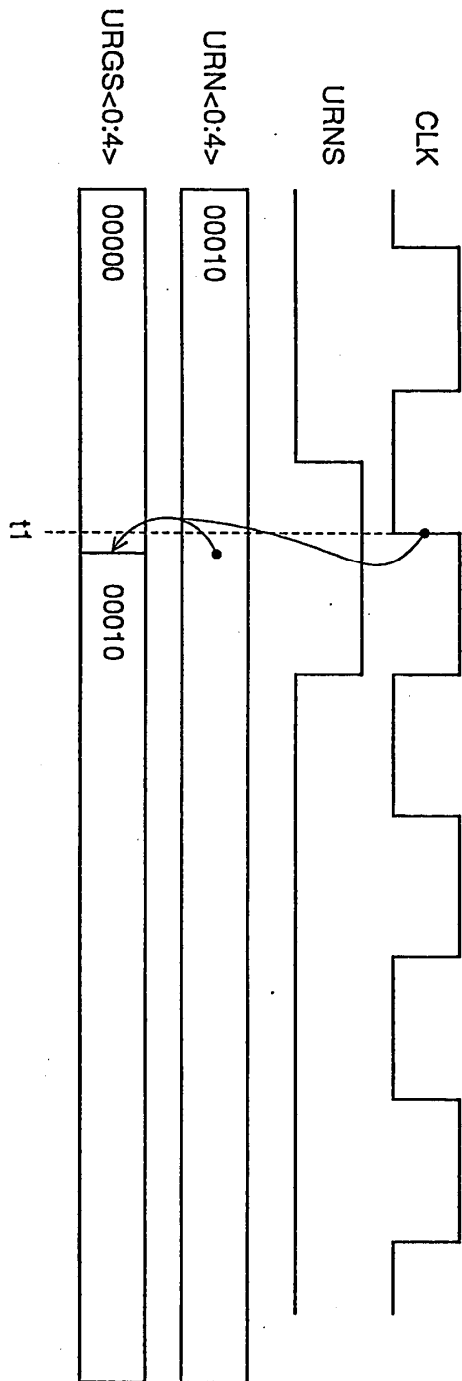

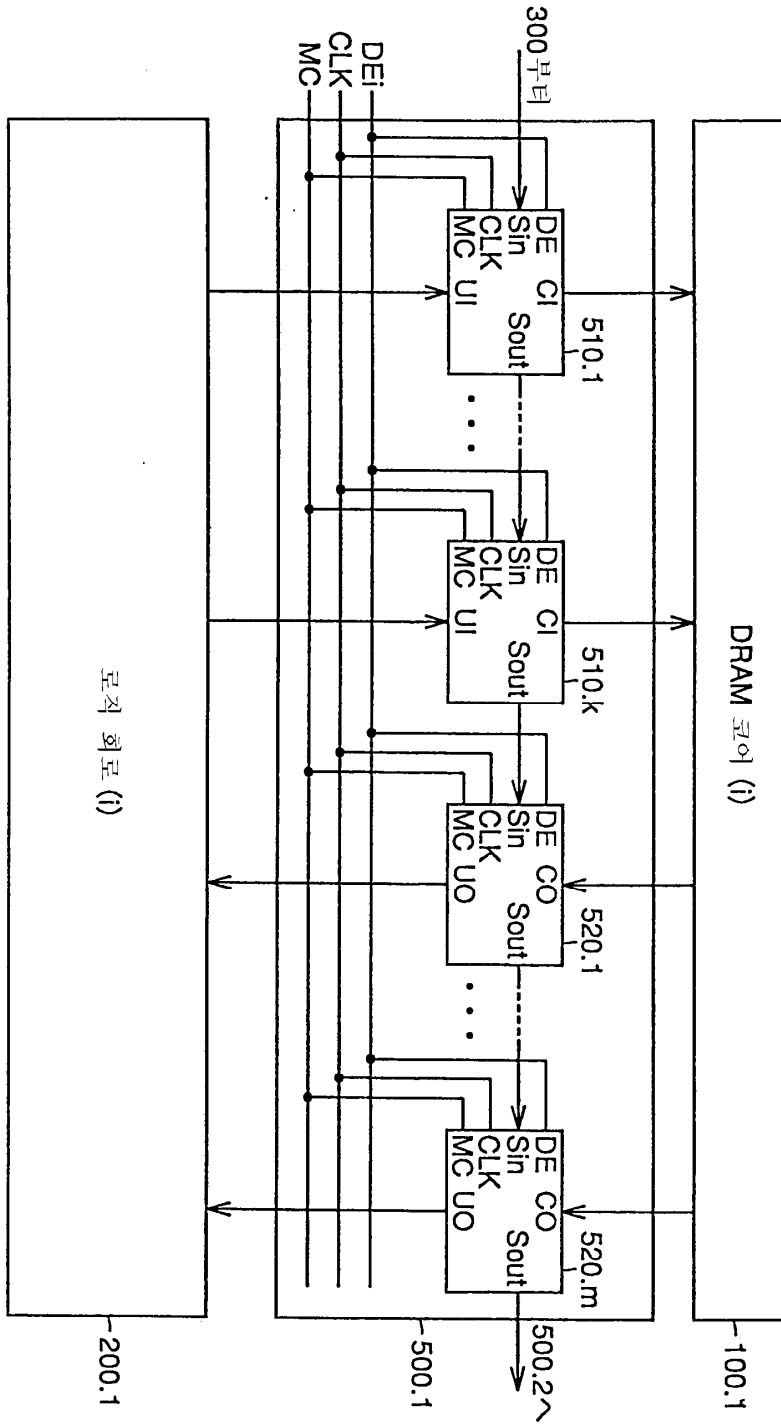

19

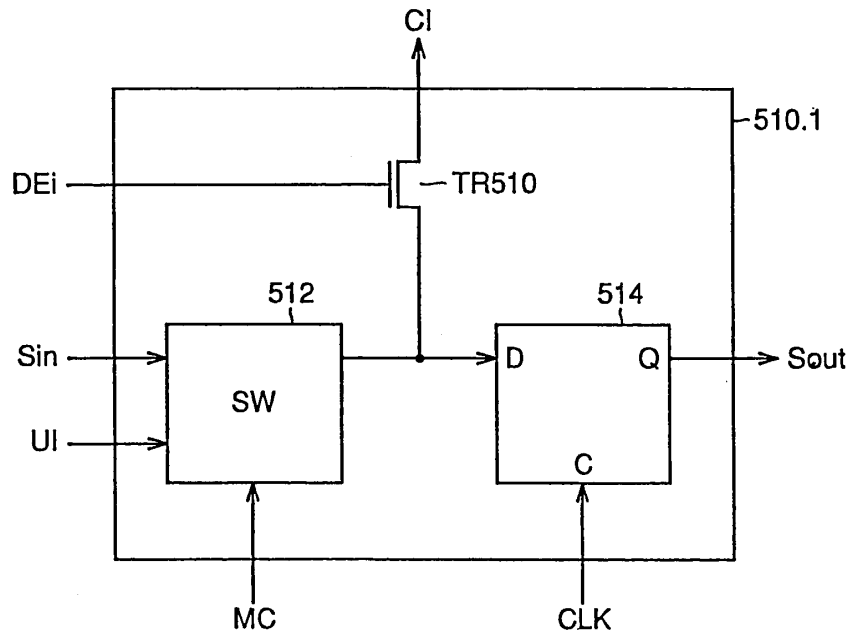

20

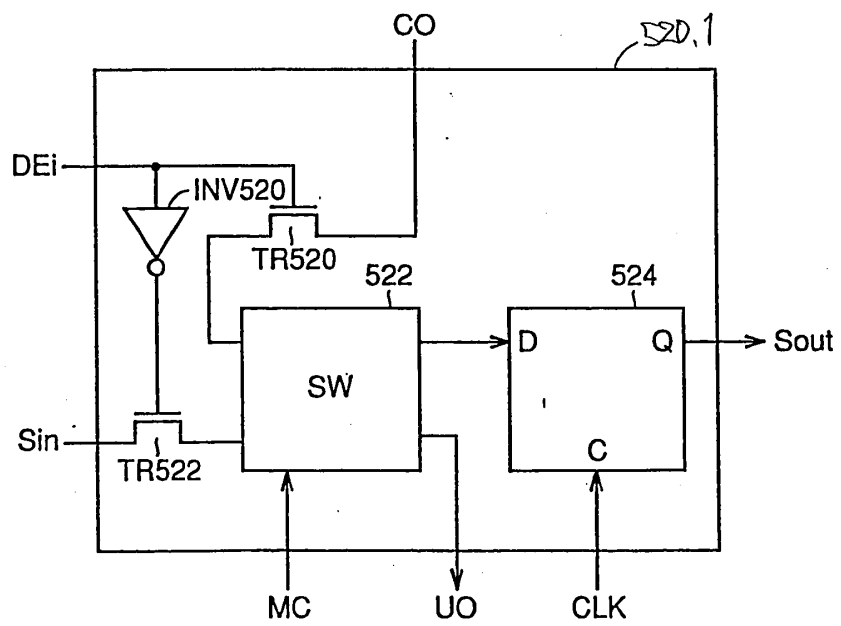

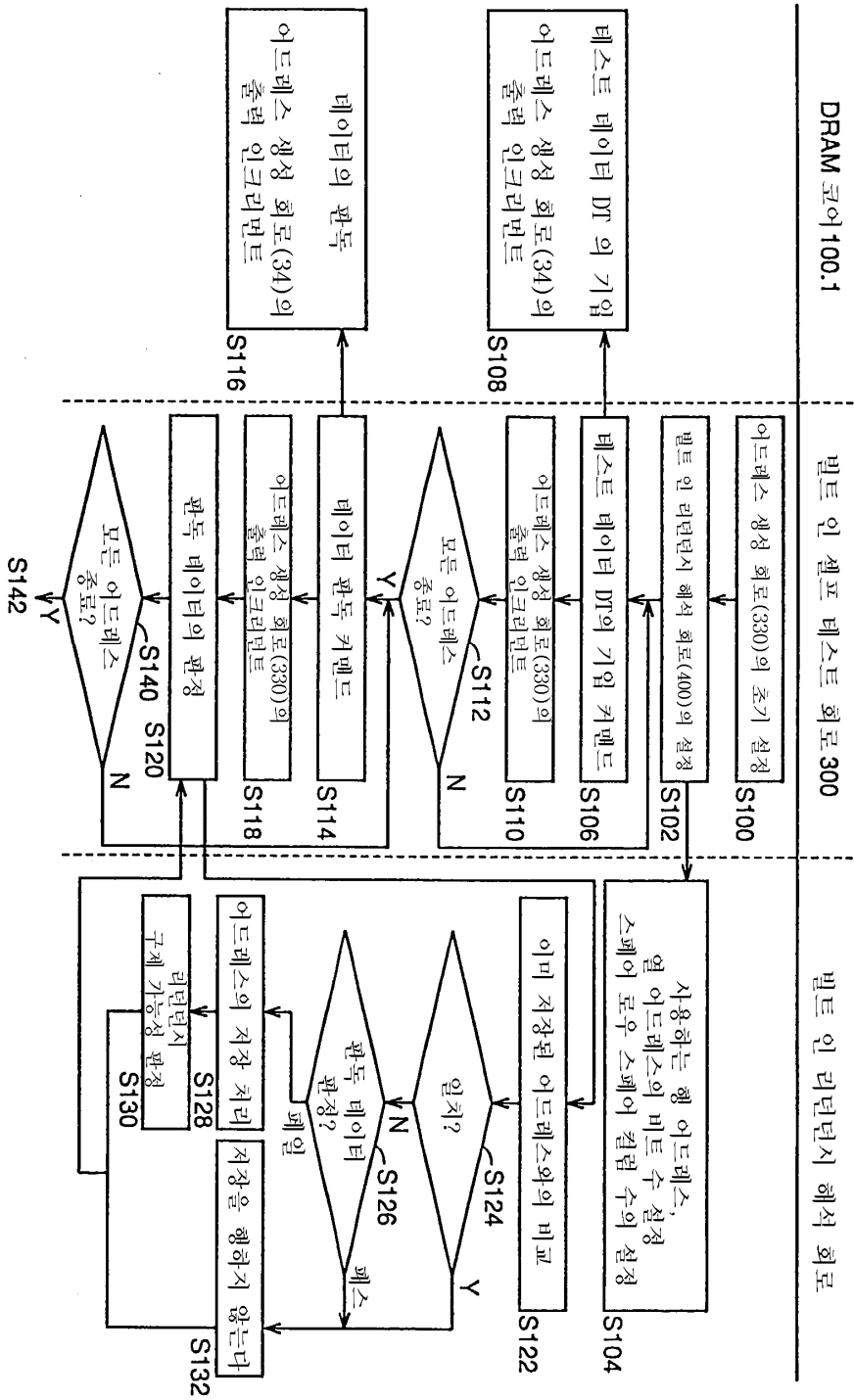

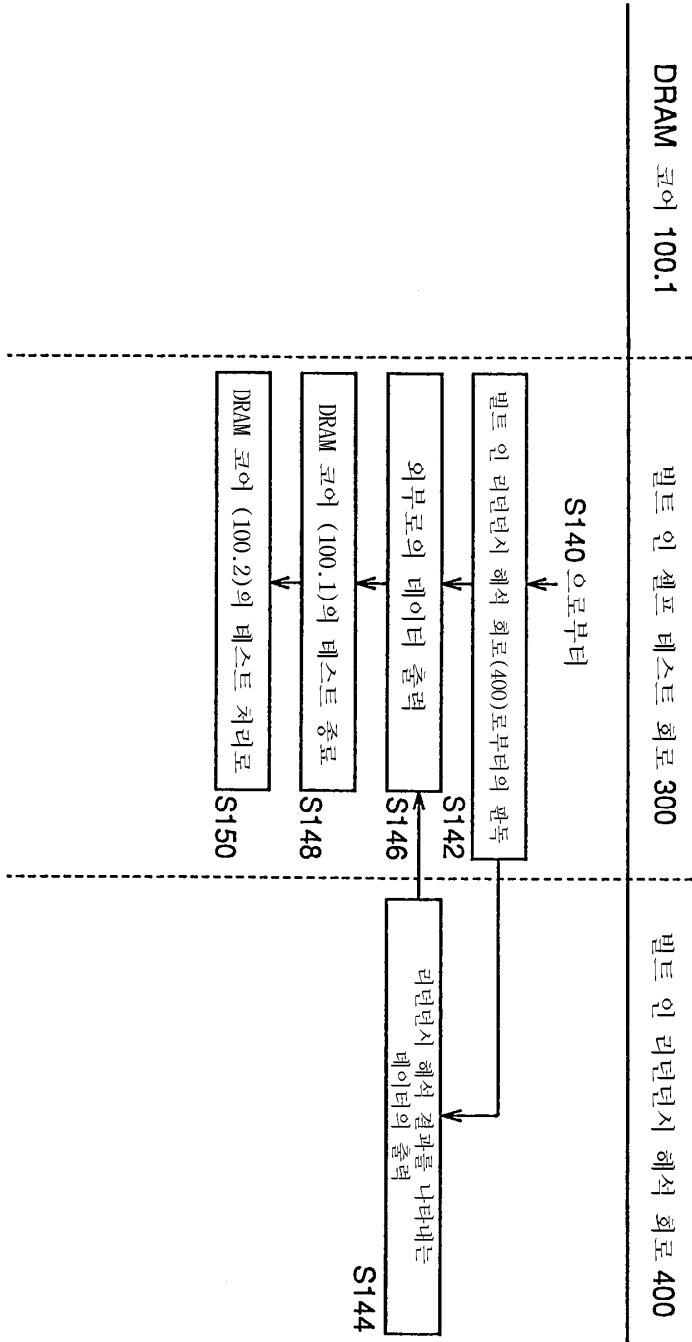

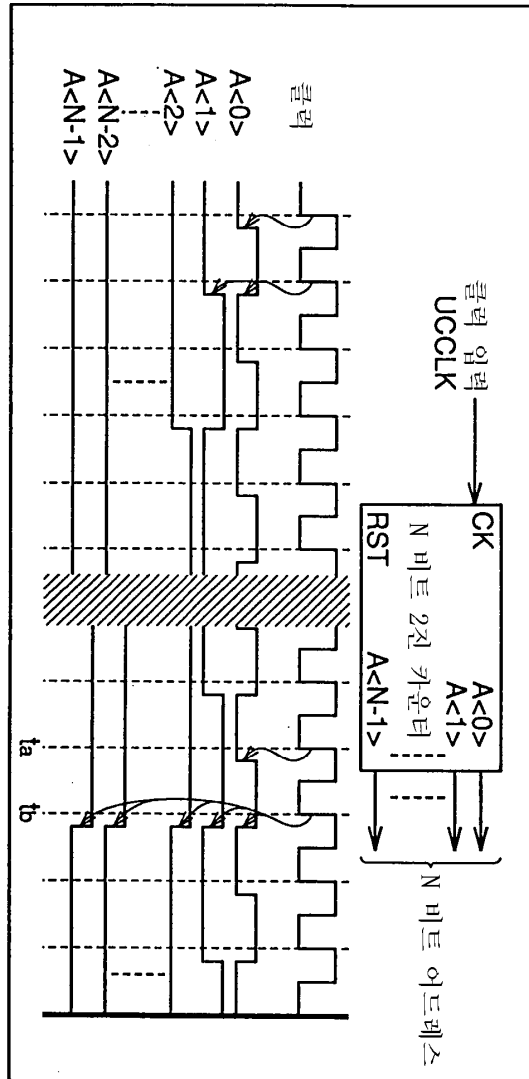

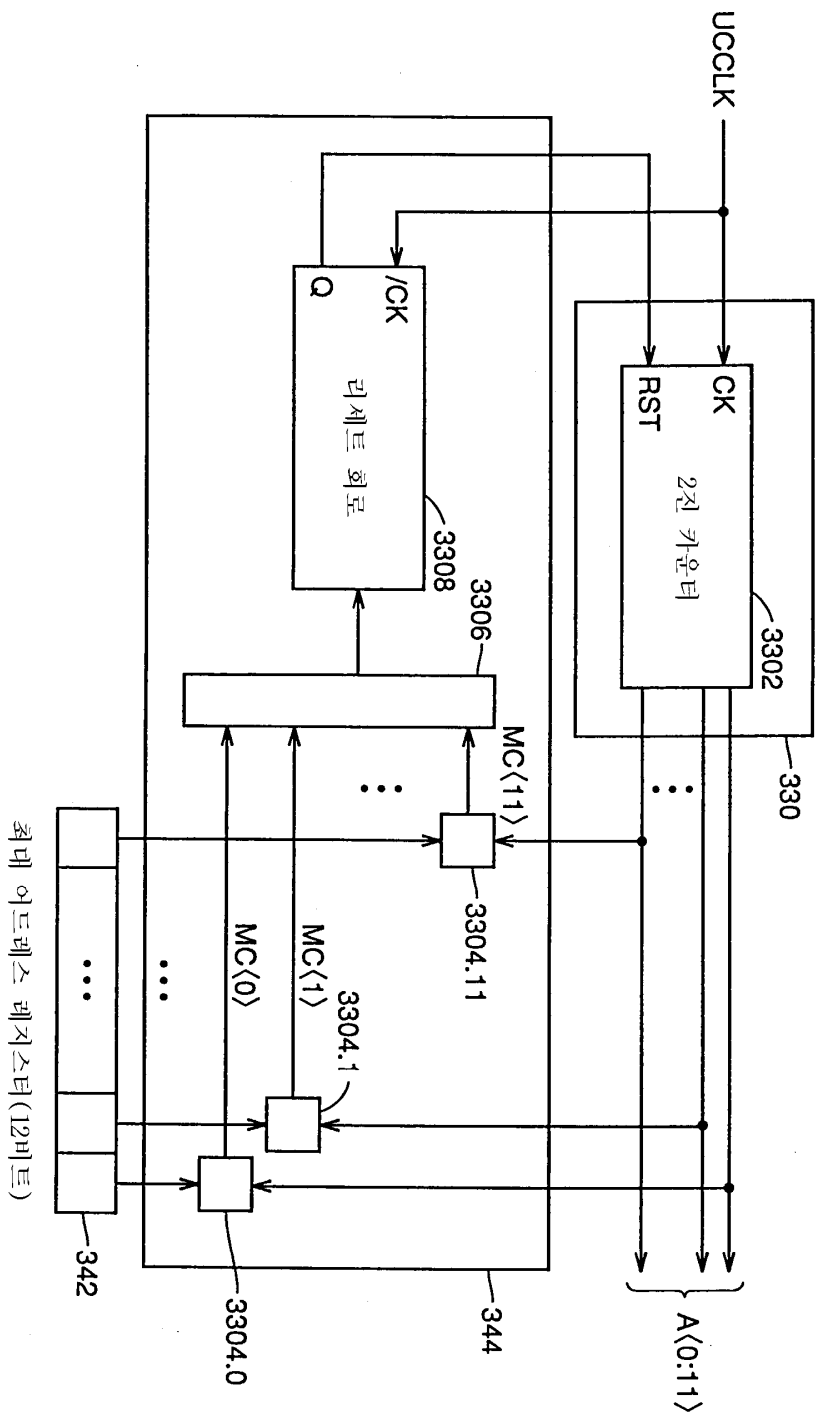

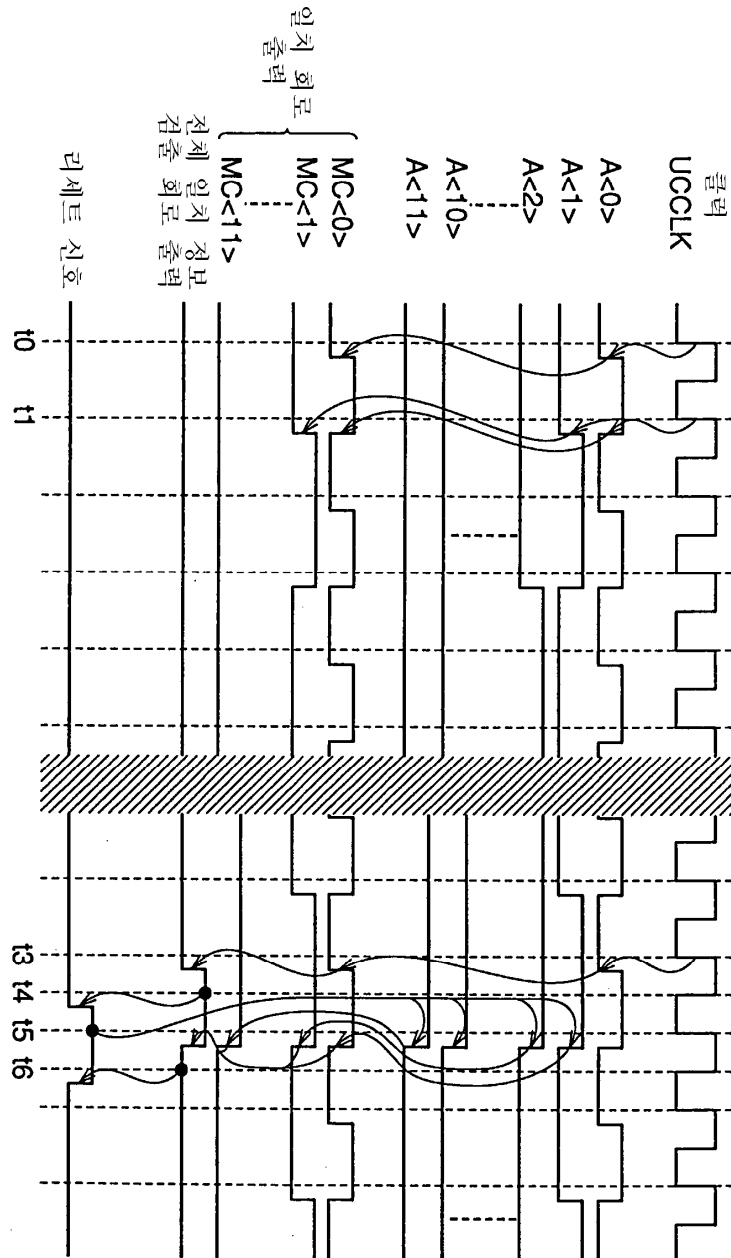



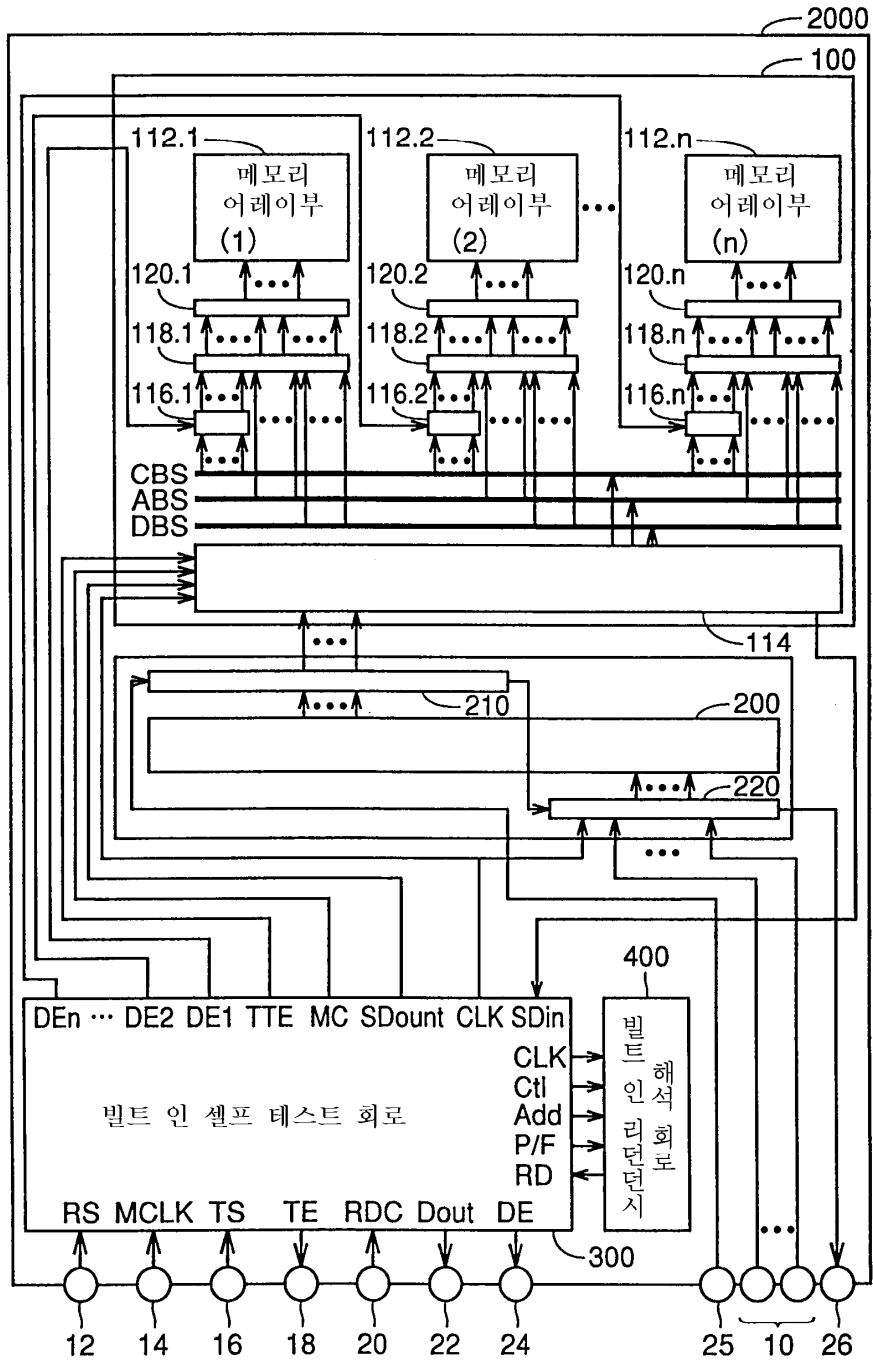

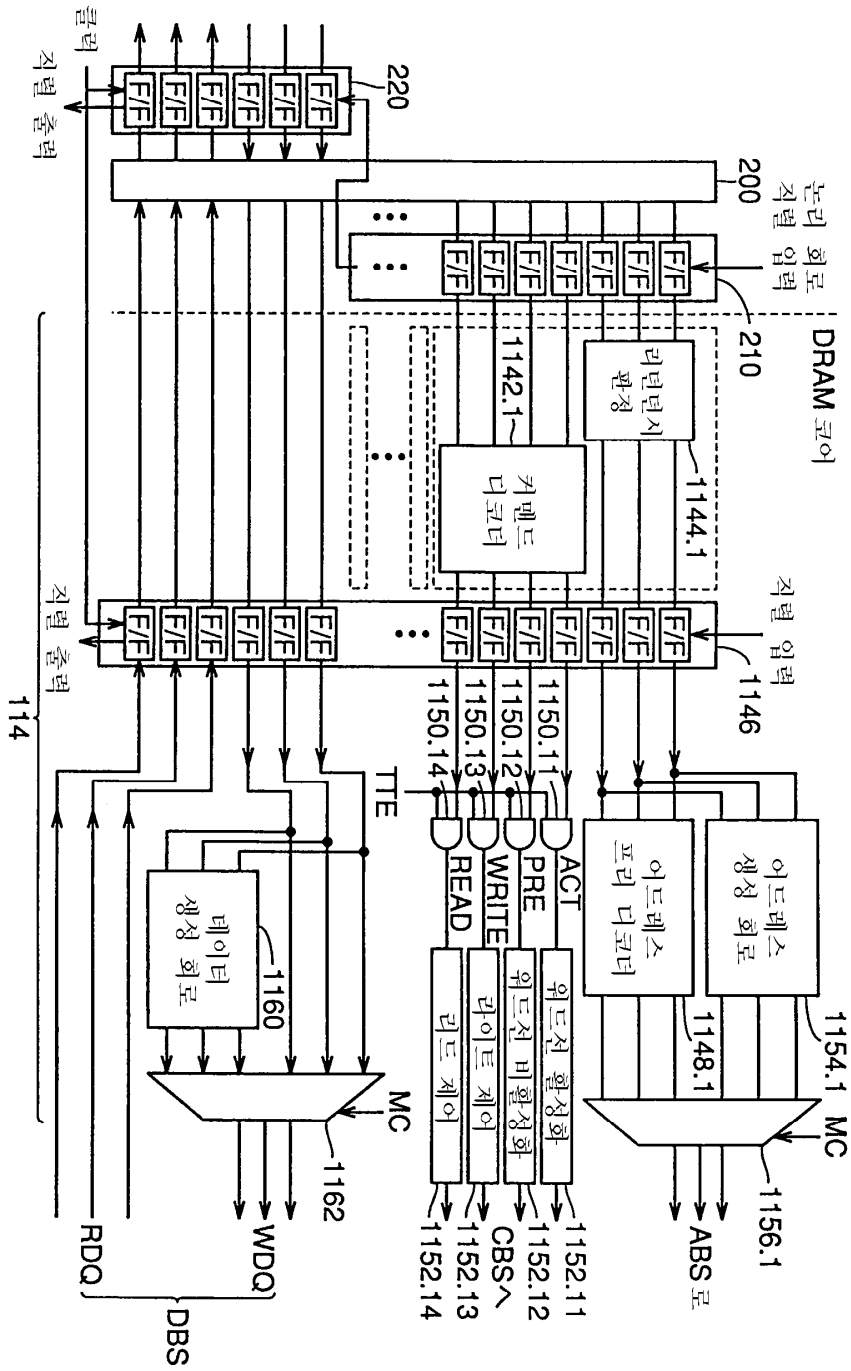

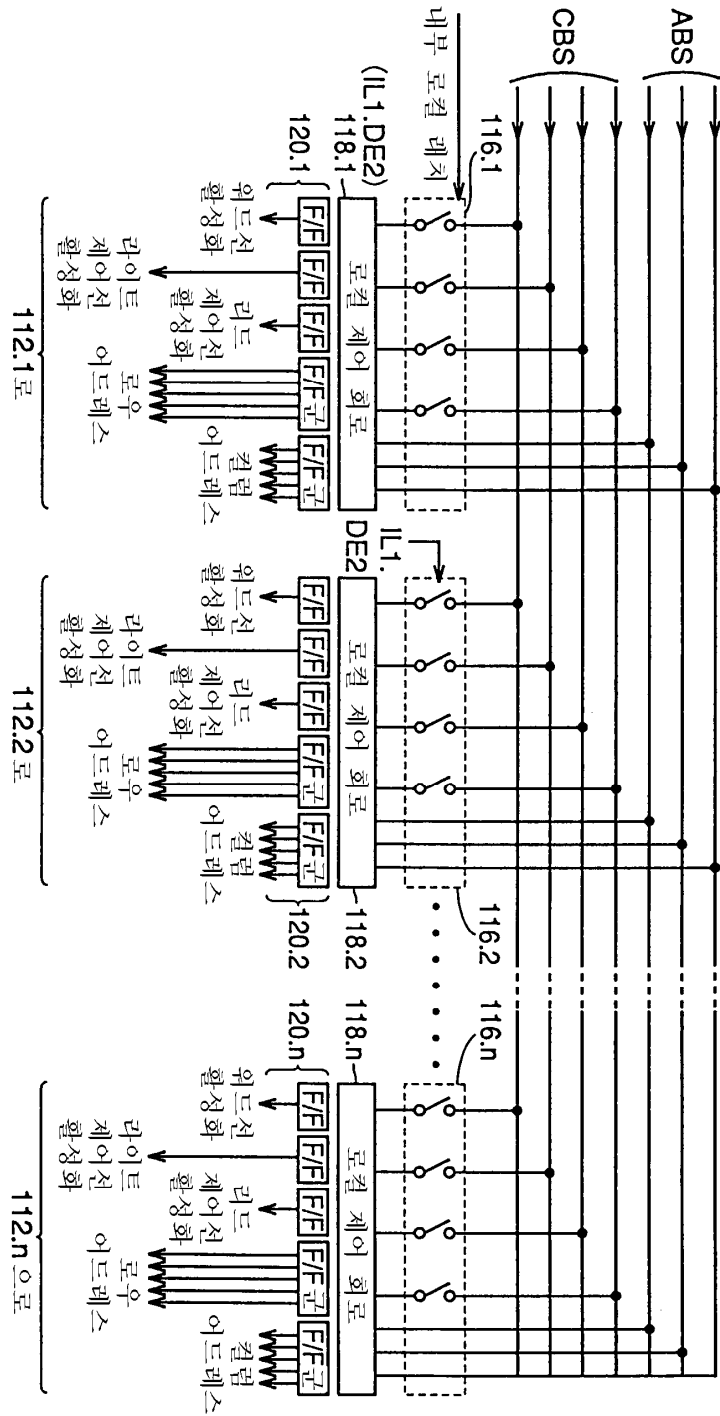

29

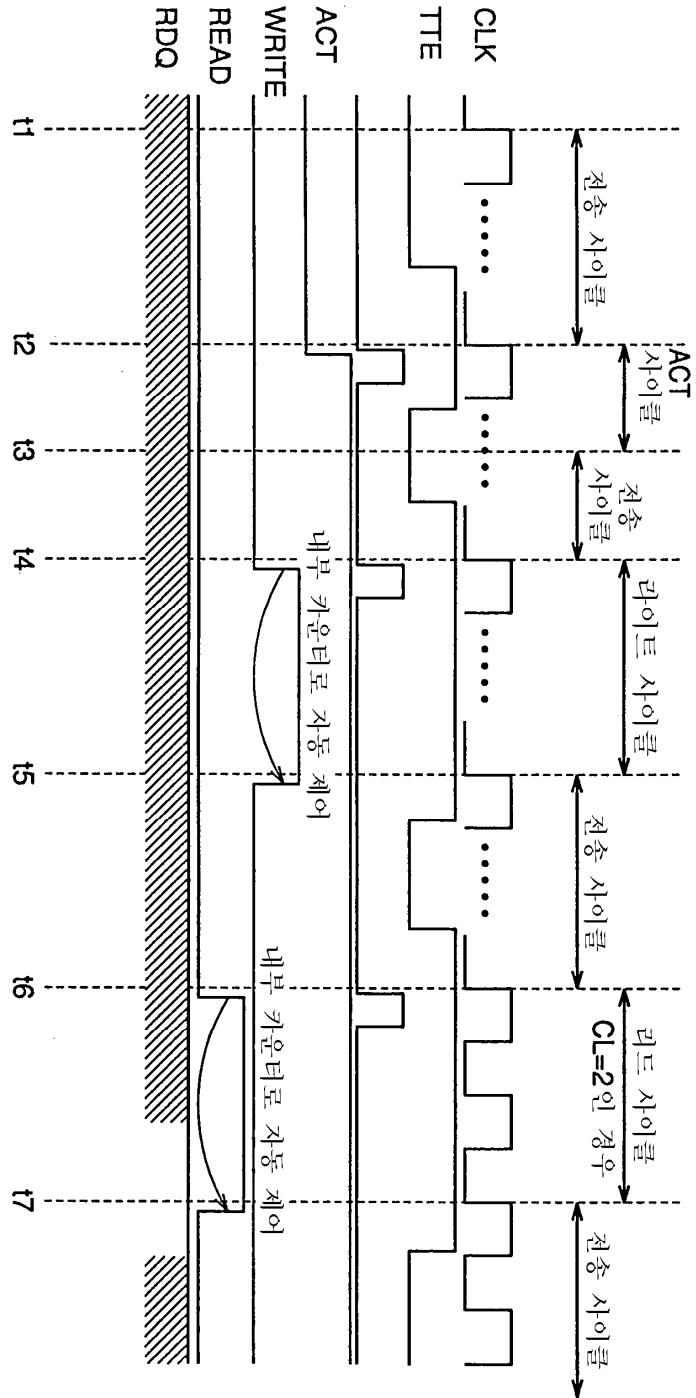

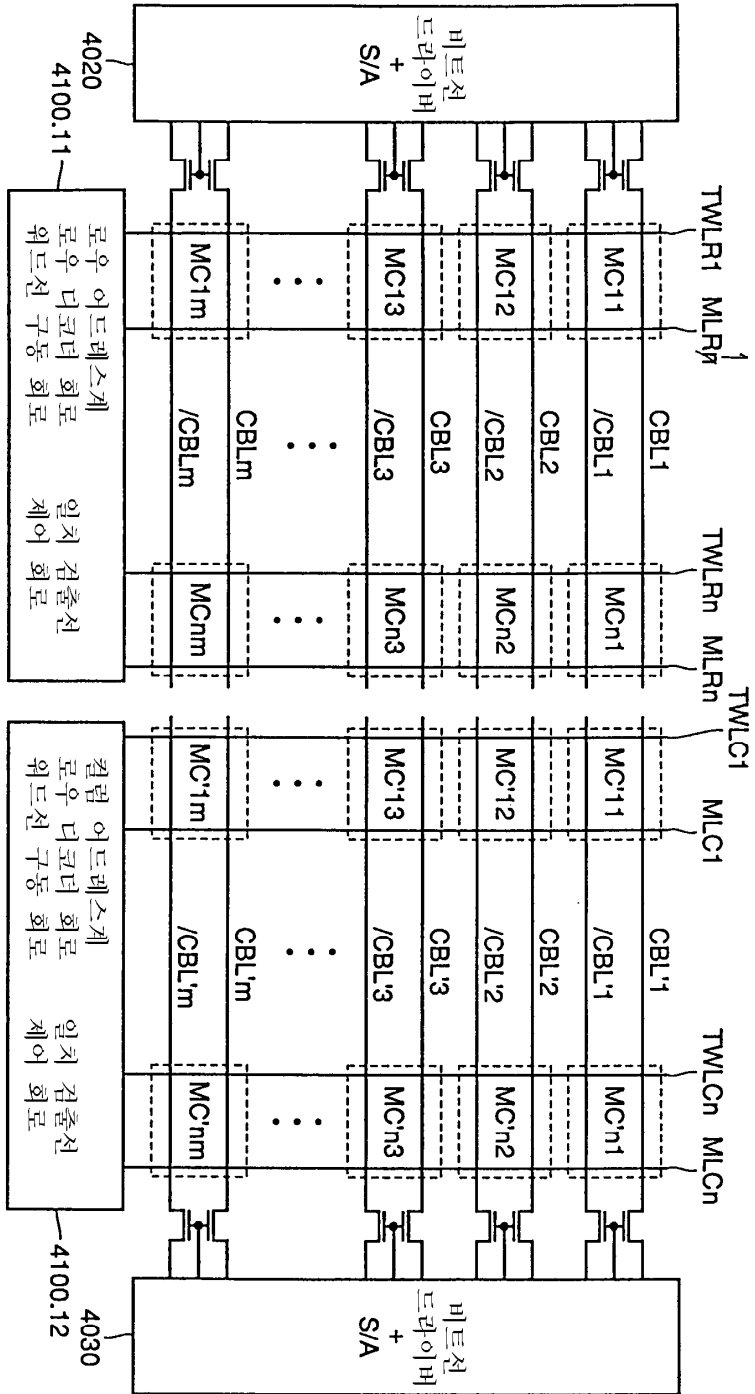

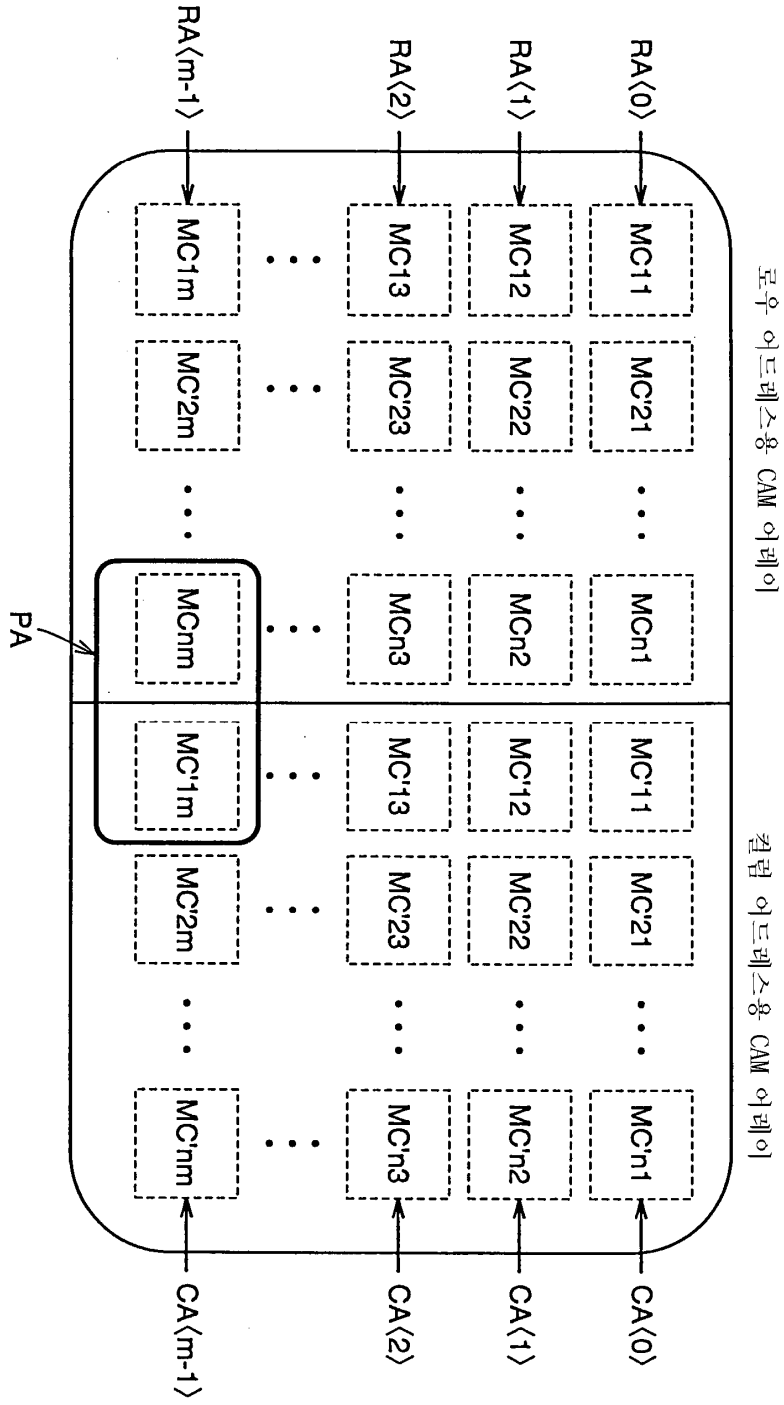

- ☒ 콘택트 홀
- ▨ 제1층 폴리 실리콘
- ▧ 제2층 폴리 실리콘
- ▩ 활성층
- ▤ 제1층 금속 배선
- ▥ 제2층 금속 배선

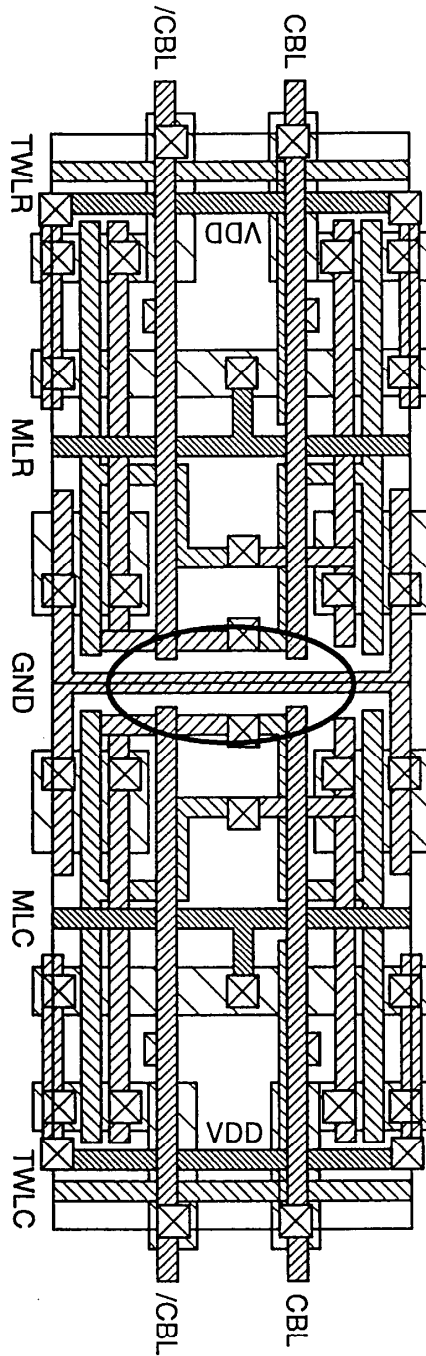

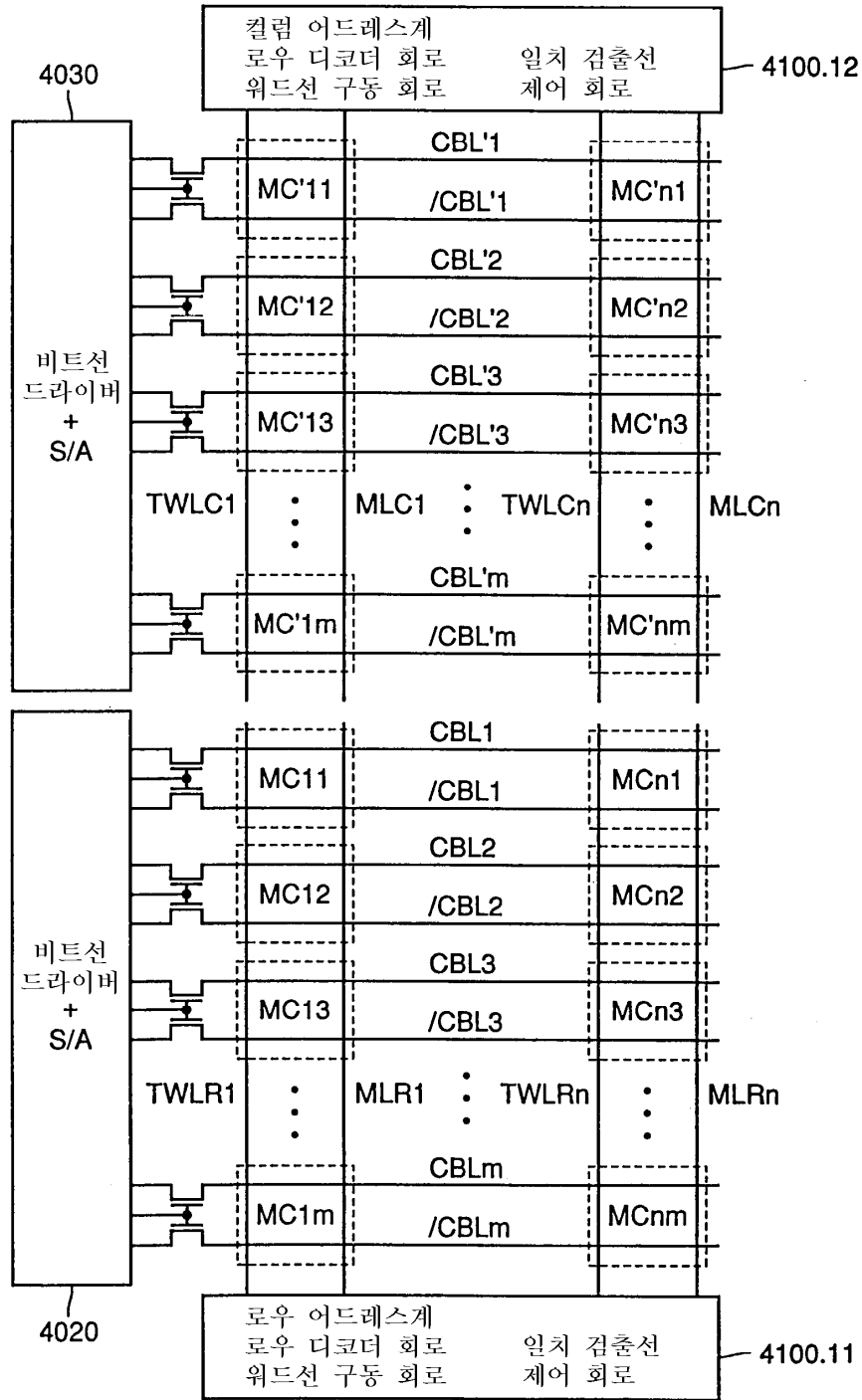



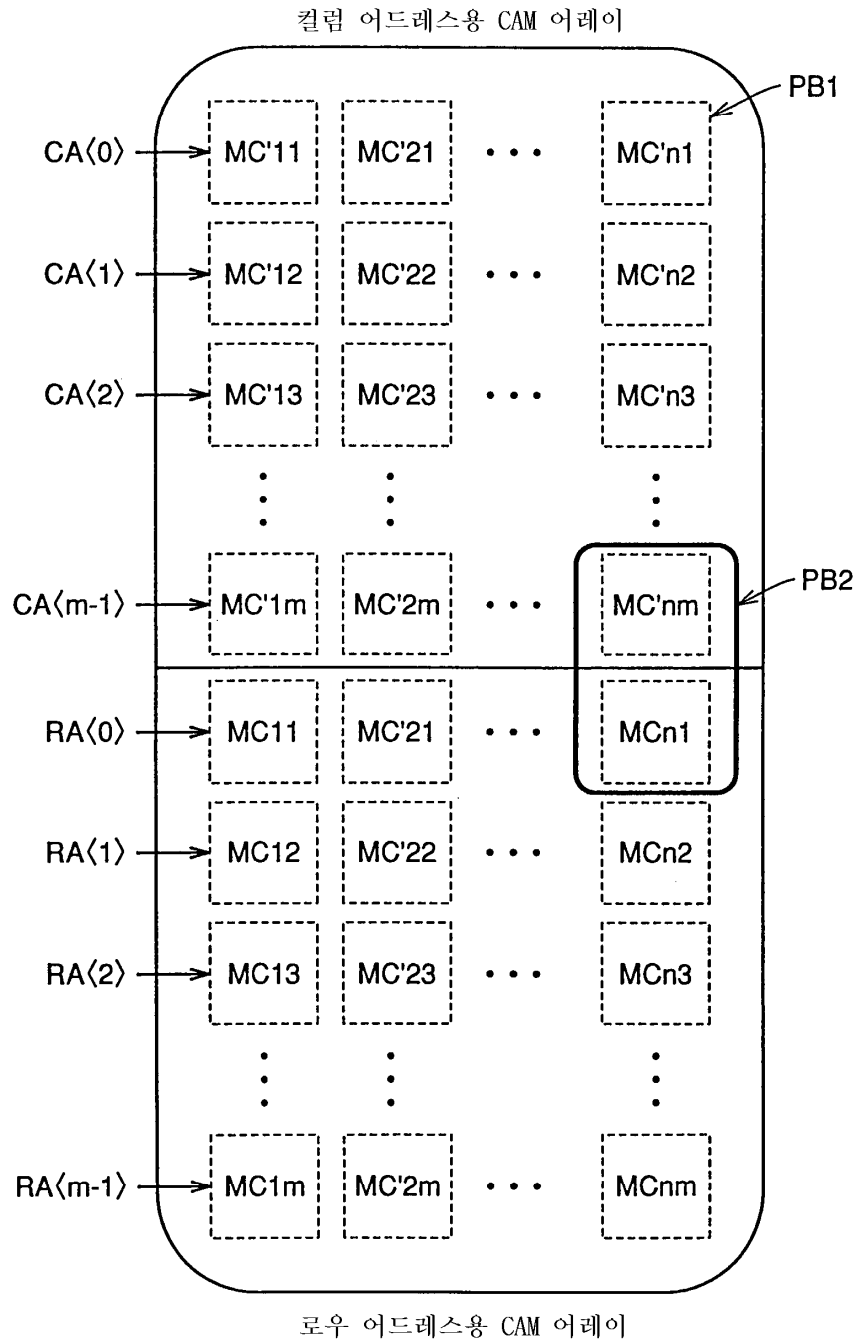

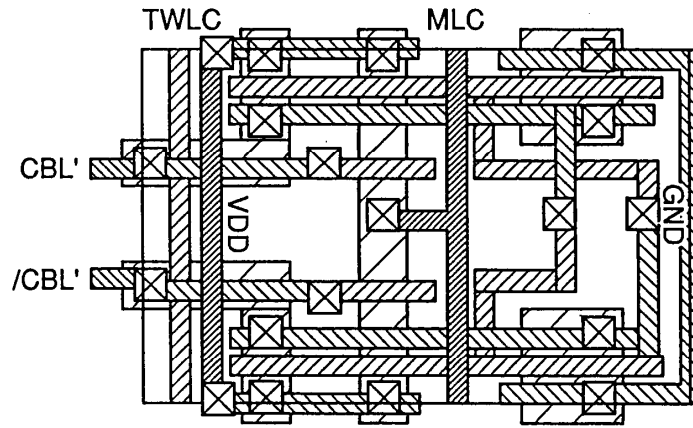

- ☒ 컨택트 홀
- ▨ 제1층 폴리 실리콘
- ▧ 제2층 폴리 실리콘
- ▩ 활성층
- ▦ 제1층 금속 배선
- ▥ 제2층 금속 배선

36

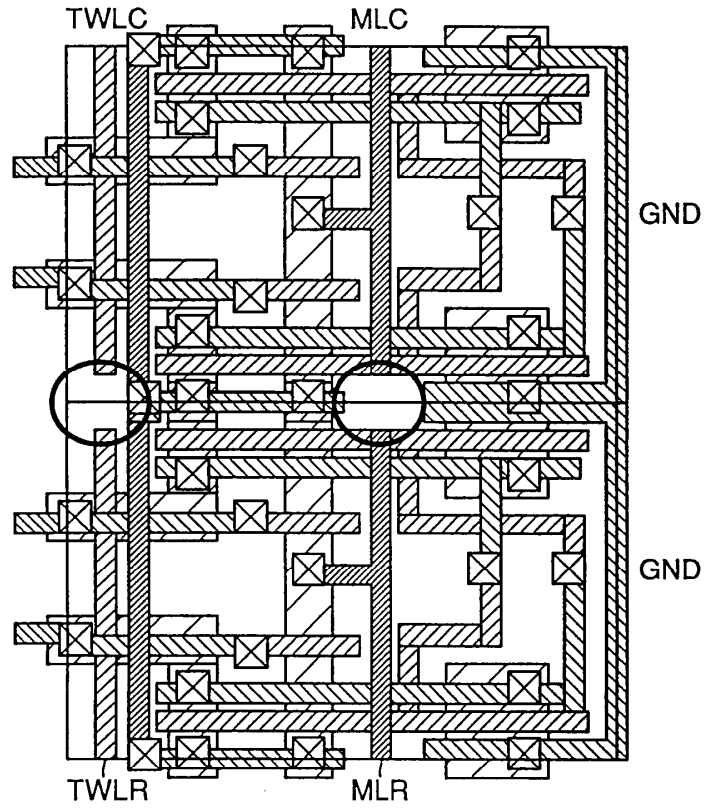

- ☒ 컨택트 홀
- ▨ 제1층 폴리 실리콘
- ▧ 제2층 폴리 실리콘
- 활성층
- ▩ 제1층 금속 배선
- 제2층 금속 배선

37

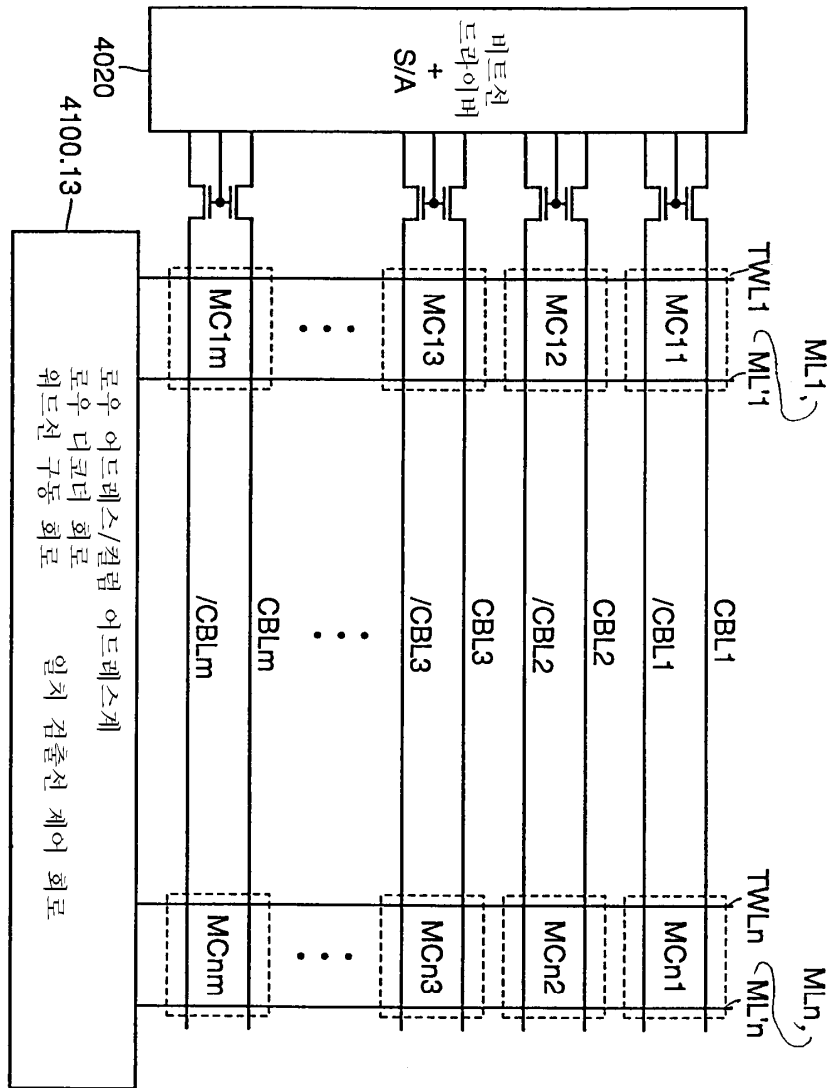

38

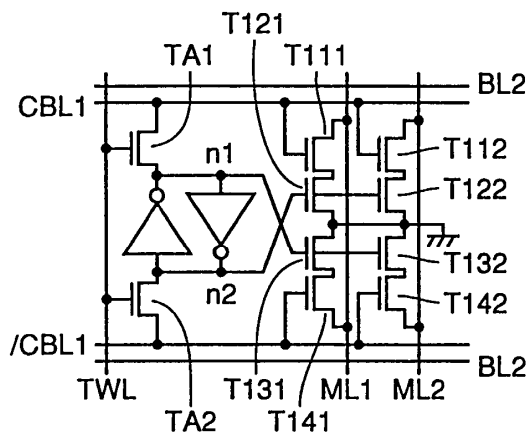

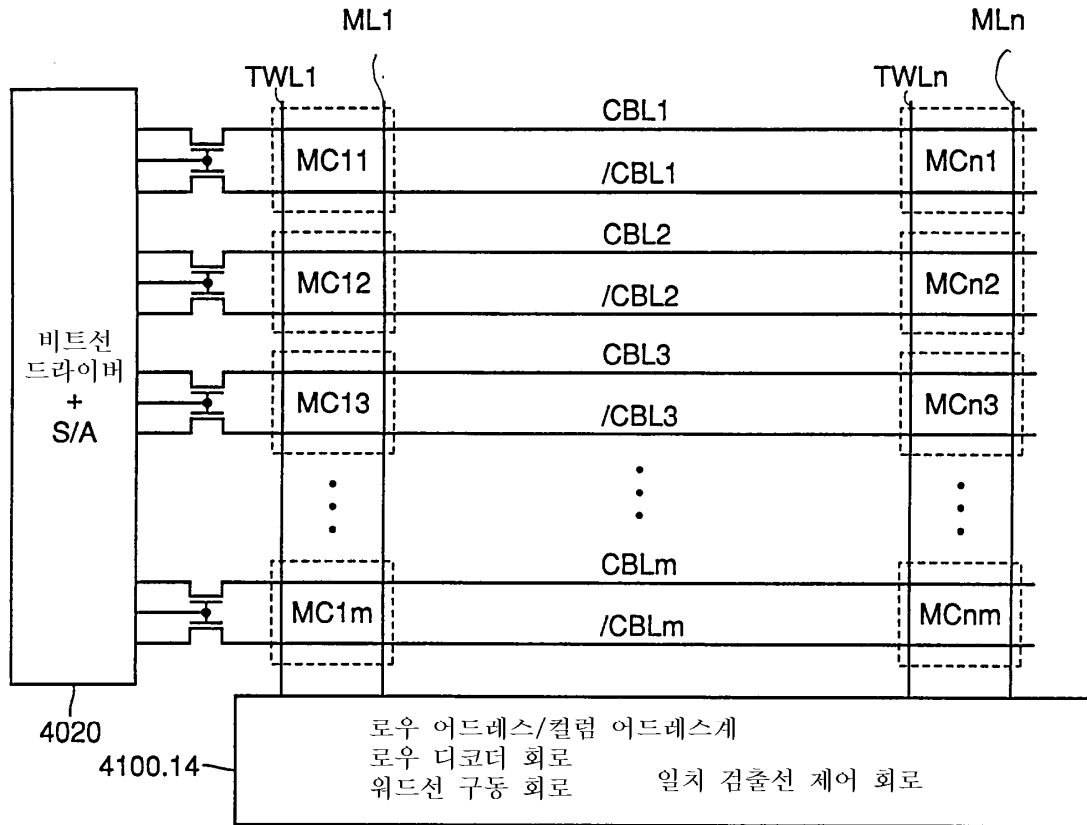

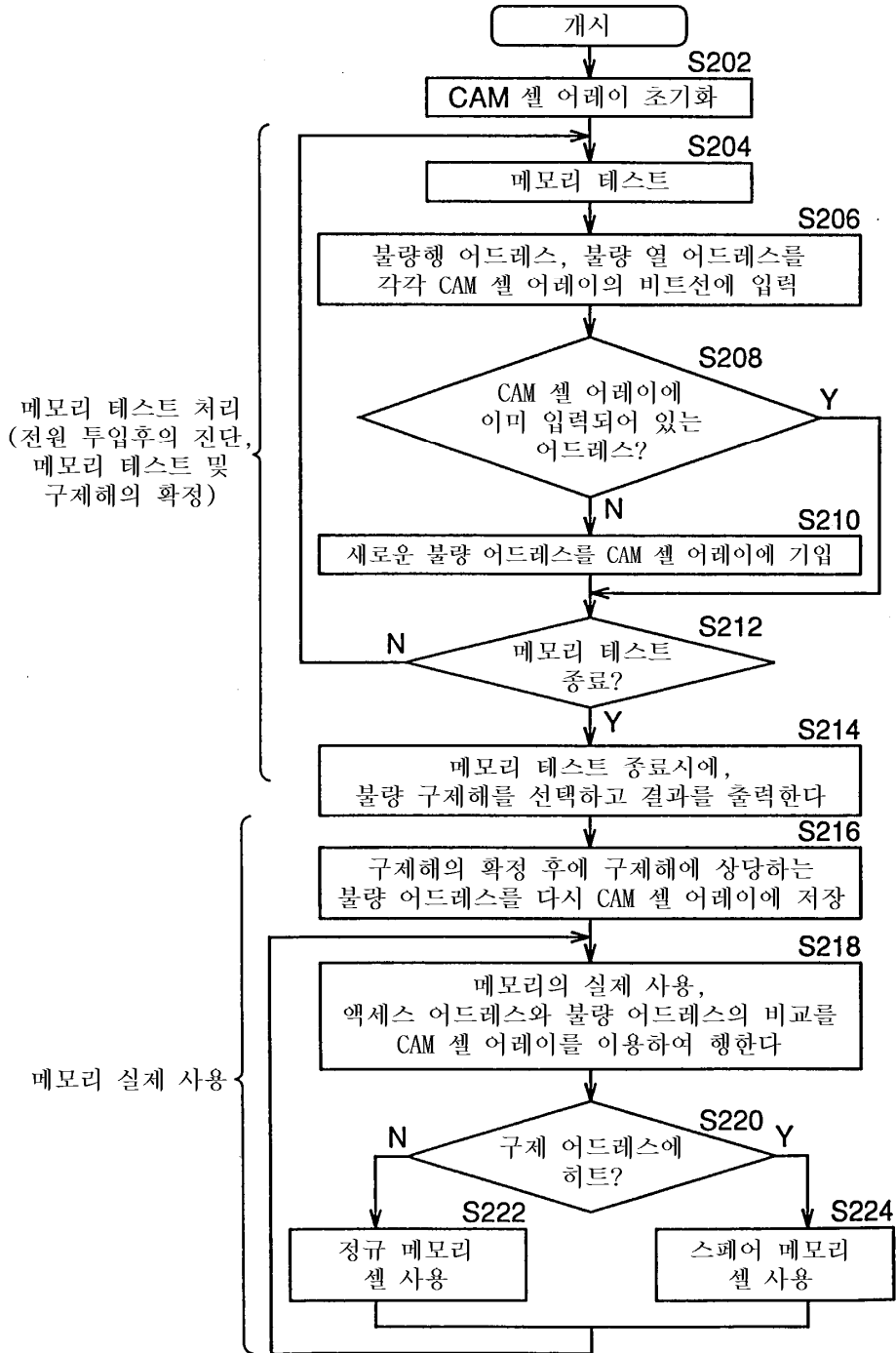

41

