



(51) International Patent Classification:

C07C 45/75 (2006.01) C07C 45/82 (2006.01)  
C07C 45/78 (2006.01) C07C 47/22 (2006.01)

Muhunthan; 400 Arcola Road, Collegeville, PA 19426 (US). SILVANO, Mark A.; 400 Arcola Road, Collegeville, PA 19426 (US).

(21) International Application Number:

PCT/US2018/034275

(74) Agent: BRANT, Edward; The Dow Chemical Company, Intellectual Property, P.O. Box 1967, Midland, Michigan 48641 (US).

(22) International Filing Date:

24 May 2018 (24.05.2018)

(81) Designated States (unless otherwise indicated, for every kind of national protection available): AE, AG, AL, AM, AO, AT, AU, AZ, BA, BB, BG, BH, BN, BR, BW, BY, BZ, CA, CH, CL, CN, CO, CR, CU, CZ, DE, DJ, DK, DM, DO, DZ, EC, EE, EG, ES, FI, GB, GD, GE, GH, GM, GT, HN, HR, HU, ID, IL, IN, IR, IS, JO, JP, KE, KG, KH, KN, KP, KR, KW, KZ, LA, LC, LK, LR, LS, LU, LY, MA, MD, ME, MG, MK, MN, MW, MX, MY, MZ, NA, NG, NI, NO, NZ, OM, PA, PE, PG, PH, PL, PT, QA, RO, RS, RU, RW, SA, SC, SD, SE, SG, SK, SL, SM, ST, SV, SY, TH, TJ, TM, TN, TR, TT, TZ, UA, UG, US, UZ, VC, VN, ZA, ZM, ZW.

(25) Filing Language:

English

(26) Publication Language:

English

(30) Priority Data:

62/510,984 25 May 2017 (25.05.2017) US  
62/525,257 27 June 2017 (27.06.2017) US

(71) Applicant: ROHM AND HAAS COMPANY [US/US]; 400 Arcola Road, Collegeville, Pennsylvania 19426 (US).

(72) Inventors: CHAKRABARTI, Reetam; 400 Arcola Road, Collegeville, PA 19426 (US). COMO, Charles; 400 Arcola Road, Collegeville, PA 19426 (US). HRUBY, Sarah L.; Vendesgatan 1C 192, SE-291 53 Kristianstad (SE). KRAPTCHEV, Dmitri A.; 400 Arcola Road, Collegeville, PA 19426 (US). NGO, Minh N.; 400 Arcola Road, Collegeville, PA 19426 (US). SATHIOSATHAM,

(84) Designated States (unless otherwise indicated, for every kind of regional protection available): ARIPO (BW, GH, GM, KE, LR, LS, MW, MZ, NA, RW, SD, SL, ST, SZ, TZ, UG, ZM, ZW), Eurasian (AM, AZ, BY, KG, KZ, RU, TJ, TM), European (AL, AT, BE, BG, CH, CY, CZ, DE, DK, EE, ES, FI, FR, GB, GR, HR, HU, IE, IS, IT, LT, LU, LV,

(54) Title: PROCESS FOR PREPARING METHACROLEIN

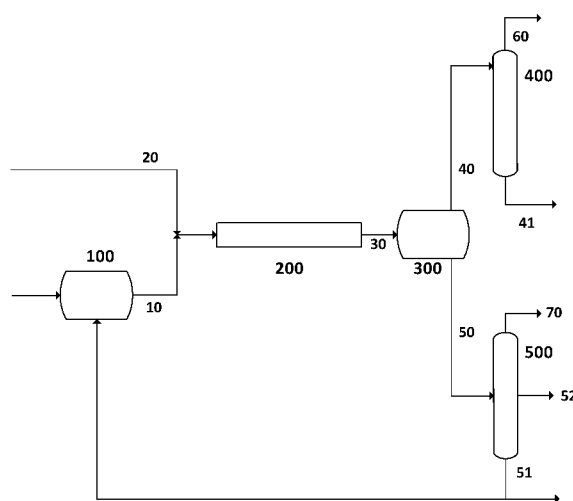

FIG. 1

(57) Abstract: Provided is a process for preparing dry methacrolein which maximizes capture of methanol. Also provided is a process for producing methyl methacrylate.



MC, MK, MT, NL, NO, PL, PT, RO, RS, SE, SI, SK, SM,  
TR), OAPI (BF, BJ, CF, CG, CI, CM, GA, GN, GQ, GW,  
KM, ML, MR, NE, SN, TD, TG).

**Published:**

— *with international search report (Art. 21(3))*

## PROCESS FOR PREPARING METHACROLEIN

### FIELD OF THE INVENTION

This invention relates to a process for preparing dry methacrolein, and to a process for  
5 making methyl methacrylate.

### BACKGROUND

Methacrolein (2-methylprop-2-enal; "MA") is a common intermediate in methyl  
methacrylate ("MMA") production. MA can be produced from ethylene (C<sub>2</sub>) feedstock, such as  
10 via liquid phase propionaldehyde condensation as disclosed in US 4,496,770. The MA product  
stream contains methanol that is supplied with formaldehyde that is used in the propionaldehyde  
condensation. Such methanol can be advantageous in a subsequent oxidative esterification  
("OER") process, which converts MA in the presence of methanol to MMA in a single step, as  
disclosed in US 5,969,178, US 6,107,515, and US 6,040,472. However, the MA product stream  
15 also contains water, which can be detrimental to the subsequent OER process. Thus, a MA  
stream from conventional processes must be sufficiently dry to be used as a feed stream for a  
downstream OER process, in addition to containing sufficient methanol and having a substantial  
absence of certain impurities (e.g., propionaldehyde, formaldehyde, acetic acid, and organic  
heavies including, but not limited to, propionic acid, methacrolein dimer, 2-methyl-2-pentenal,  
20 and other methacrolein oligomers) that can have a negative effect on efficiency of the OER  
process.

Processes for preparing dry MA have been described in the art. For example, US  
2016/0229779 discloses a process comprising (a) providing a wet MA stream containing MA,

methanol, and at least 8 weight % water to a phase separator, (b) separating the MA stream into organic and aqueous phases, (c) distilling the organic phase to produce a product stream containing MA and a first overhead stream, (d) sending the first overhead stream back to the phase separator, and (e) distilling the aqueous phase to produce a second overhead stream that is recycled back to the phase separator. The prior art does not, however, disclose a process that further maximizes methanol capture for use in a downstream OER process, or further minimizes certain impurities that can negatively affect the efficiency of the OER process.

Accordingly, there is a need to develop processes for drying wet MA prepared from an ethylene (C<sub>2</sub>) feedstock, wherein methanol is efficiently captured for a downstream OER process while also removing detrimental impurities.

## STATEMENT OF INVENTION

A process for preparing methacrolein comprising (a) mixing water and an amine-acid catalyst to provide a catalyst stream [10], (b) sending the catalyst stream and a reaction stream [20] comprising propionaldehyde, formaldehyde, and methanol to a reactor [200] to produce a first intermediate stream [30] comprising methacrolein, methanol, and at least 8 weight % water, (c) providing the first intermediate stream [30] to a phase separator [300] to produce (i) an organic phase [40] comprising (A) less than 4 weight % water, and (B) at least 70 weight % methacrolein, and (ii) an aqueous phase [50] comprising methacrolein, methanol, amine-acid catalyst, and at least 70 weight % water, wherein the phase separator [300] is operated at a temperature of less than 25°C, (d) distilling the organic phase in a first distillation column [400] to produce (i) a first product stream [60] comprising (A) methacrolein and methanol in a combined amount of at least 95 weight %, (B) less than 4 weight % water, and (C) less than 1

weight % of impurities comprising one or more of acetic acid, propionic acid, methacrolein dimer, and 2-methyl-2-pentenal, and (ii) a first waste stream [41], (e) distilling the aqueous phase [50] in a second distillation column [500] to produce (i) a second product stream [70] comprising methacrolein, methanol, and less than 5 weight % water, (ii) a bottoms stream [51] comprising  
5 amine-acid catalyst, and (iii) a side draw stream [52] comprising water and less than 2 weight % methanol, and (h) recycling at least part of the bottoms stream [51] to the catalyst stream [10].

In another aspect of the invention, the propionaldehyde is produced by contacting ethylene with CO and H<sub>2</sub> in the presence of a hydroformylation catalyst.

Another aspect of the invention further comprises providing at least part of the first  
10 product stream and at least part of the second product stream to a process comprising contacting the methacrolein with methanol and an oxygen-containing gas in the presence of an oxidative esterification catalyst to produce methyl methacrylate.

## BRIEF DESCRIPTION OF THE FIGURES

15 FIG. 1 is a schematic of an embodiment of the invention.

## DETAILED DESCRIPTION

The inventors have now surprisingly found a process for drying wet methacrolein (“MA”) prepared from an ethylene (C<sub>2</sub>) feedstock, wherein methanol is efficiently captured for a  
20 downstream oxidative esterification reaction (“OER”) process while also removing detrimental impurities.

One embodiment of the invention is shown in FIG 1. A catalyst stream 10 is provided by mixing water and an amine-acid catalyst. In certain embodiments, the water and catalyst are

mixed in a catalyst tank **100**. The amine-acid catalyst is capable of catalyzing the Mannich condensation of propionaldehyde and formaldehyde to methacrolein. The Mannich condensation process is known in the art, for example, as described in U.S. Patent No. 4,496,770 and U.S. Patent No. 7,141,702. Suitable amine-acid catalysts include, for example, those comprising a  
5 secondary amine, e.g., dimethylamine, and an acid, e.g., acetic acid.

Suitable acids of the amine-acid catalysts include, for example, inorganic acids and organic mono-, di-, or polycarboxylic acids. Suitable carboxylic acids include, for example, aliphatic C<sub>1</sub>-C<sub>10</sub> monocarboxylic acids, C<sub>2</sub>-C<sub>10</sub> dicarboxylic acids, C<sub>2</sub>-C<sub>10</sub> polycarboxylic acids. In certain embodiments, the acid comprises at least one of acetic acid, propionic acid,  
10 methoxyacetic acid, n-butyric acid, isobutyric acid, oxalic acid, succinic acid, tartaric acid, glutaric acid, adipic acid, maleic acid, fumaric acid, and combinations thereof. Suitable inorganic acids include, for example, sulfuric acid and phosphoric acid.

Suitable amines of the amine-acid catalysts include, for example, those of the formula NHR<sup>2</sup>R<sup>3</sup>, where R<sup>2</sup> and R<sup>3</sup> are each independently C<sub>1</sub>-C<sub>10</sub> alkyl, which are optionally substituted  
15 with an ether, hydroxyl, secondary amino or tertiary amino group, or R<sup>2</sup> and R<sup>3</sup>, together with the adjacent nitrogen, may form a C<sub>5</sub>-C<sub>7</sub> heterocyclic ring, optionally containing a further nitrogen atom and/or an oxygen atom, and which are optionally substituted by a C<sub>1</sub>-C<sub>4</sub> alkyl or C<sub>1</sub>-C<sub>4</sub> hydroxyalkyl. In certain embodiments, the amine comprises at least one of dimethylamine, diethylamine, methylethylamine, methylpropylamine, dipropylamine, dibutylamine,  
20 diisopropylamine, diisobutylamine, methylisopropylamine, methylisobutylamine, methyl-sec.-butylamine, methyl-(2-methylpentyl)-amine, methyl-(2-ethylhexyl)-amine, pyrrolidine, piperidine, morpholine, N-methylpiperazine, N-hydroxyethylpiperazine, piperazine,

hexamethyleneimine, diethanolamine, methylethanolamine, methylcyclohexylamine, methylcyclopentylamine, and dicyclohexylamine, and combinations thereof.

In certain embodiments, the amine-acid catalyst comprises dimethylamine and acetic acid. In certain embodiments, the molar ratio of the amine to acid is such that the resulting pH is  
5 from 2.5 to 7. For example, in certain embodiments the amine-acid catalyst contains a molar ratio of dimethylamine to acetic acid in an amount of from 10:1 to 1:10, preferably of from 5:1 to 1:5, and more preferably of from 1:1 to 1:1.2.

The Mannich condensation reaction is carried out by sending the catalyst stream **10** and a reaction stream **20** containing propionaldehyde, formaldehyde, and methanol to a reactor **200** to  
10 produce a first intermediate stream **30** containing methacrolein, methanol, and water via the Mannich condensation reaction. The reaction can be carried out under any suitable conditions at which the reaction proceeds. For example, the reaction can be conducted at a temperature of at least 20°C and at least atmospheric pressure. In certain embodiments, the reaction is conducted in the liquid phase at above 100°C, e.g., 150-220°C, at superatmospheric pressure, e.g., 10-80  
15 bar, and reactor residence times between 0.01 to 30 minutes. The molar ratio of propionaldehyde to formaldehyde is not particularly limited. For example, in certain embodiments the reaction stream **20** contains a ratio of propionaldehyde to formaldehyde in an amount of from 1.1:1 to 1:2, preferably of from 1.1:1 to 1:1.5, and more preferably of from 1.05:1 to 1:1.05. The first intermediate stream **30** is considered a “wet” methacrolein stream in that it comprises at least 8  
20 weight %, or at least 10 weight % water, or at least 20 weight % water, or at least 40 weight % water, based on the total weight of the first intermediate stream **30**. In certain embodiments, the methanol and formaldehyde present in the reaction stream **20** are provided in the form of formalin. In certain embodiments, the formalin utilized in the process of the invention is a

saturated water solution containing formaldehyde in an amount of about 37 weight %, and methanol in an amount of from 10 to 15 weight %, based on the total weight of the formalin. The methanol present in the formalin can be advantageous in a subsequent oxidative esterification process, which converts methacrolein in the presence of methanol to methyl methacrylate. In certain embodiments, methanol can be introduced at various locations in the process. The inventors have surprisingly found that the efficient capture of methanol from the first intermediate feed stream **30** used as a source for the subsequent oxidative esterification process is beneficially achieved by the process of the current invention.

Accordingly, the first intermediate stream **30** is sent to a phase separator **300** to produce an organic phase **40** and aqueous phase **50**. The organic phase **40** contains water, methanol, and primarily methacrolein. In certain embodiments, the methacrolein is present in the organic phase **40** in an amount of at least 70 weight %, preferably at least 85 weight %, and more preferably at least 90 weight %, based on the total weight of the organic phase **40**. In certain embodiments, the methanol is present in the organic phase **40** in an amount of less than 10 weight %, preferably less than 3 weight %, and more preferably less than 2.5 weight %, based on the total weight of the organic phase **40**. In certain embodiments, water is present in the organic phase **40** in an amount of less than 4 weight %, preferably less than 3 weight %, and more preferably less than 2 weight %, based on the total weight of the organic phase. While not wishing to be bound by theory, it is believed that operating the phase separator **300** at low temperatures results in the organic phase **40** containing lower amounts of water, which is beneficial for any downstream oxidative esterification process. Accordingly, in certain embodiments the phase separator **300** is operated at a temperature of less than 15°C, preferably less than 10°C, and more preferably less than 5°C. The aqueous phase **50** contains methacrolein, methanol, amine-acid catalyst, and

primarily water. In certain embodiments, water is present in the aqueous phase **50** in an amount of at least 70 weight %, preferably at least 75 weight %, and more preferably at least 80 weight %, based on the total weight of the aqueous phase **50**.

The organic phase **40** is then distilled in a first distillation column **400** to produce a first  
5 product stream **60** and waste stream **41**. The first product stream **60** contains water, methanol,  
and primarily methacrolein. In certain embodiments, the methacrolein is present in the first  
product stream **60** in an amount of at least 70 weight %, preferably at least 85 weight %, and  
more preferably at least 95 weight %, based on the total weight of the first product stream **60**. In  
certain embodiments, methanol is present in the first product stream **60** in an amount of less than  
10 30 weight %, preferably less than 10 weight %, and more preferably less than 2 weight %, based  
on the total weight of the first product stream **60**. In certain embodiments, the methacrolein and  
methanol are present in the first product stream **60** in a combined amount of at least 95 weight  
%, preferably at least 96 weight %, and more preferably at least 97 weight %. In certain  
embodiments, water is present in the first product stream **60** in an amount of less than 4 weight  
15 %, preferably less than 3 weight %, and more preferably less than 2 weight %, based on the total  
weight of the first product stream **60**. In certain embodiments, the first product stream **60**  
contains impurities comprising one or more of acetic acid, propionic acid, methacrolein dimer,  
and 2-methyl-2-pentenal in a combined amount of less than 1 weight %, preferably less than 0.5  
weight %, and more preferably less than 0.2 weight %, based on the total amount of the product  
20 stream **60**. The waste stream **41** contains undesired organic compounds from the process, e.g.,  
methacrolein dimer, 2-methyl-2-pentenal, inhibitor, and other heavy organic compounds from  
the process.

The aqueous phase **50** is distilled in a third distillation column **500** to produce a second product stream **70**, a bottoms stream **51**, and a side draw stream **52**. The second product stream **70** contains water, methanol, and methacrolein. In certain embodiments, water is present in the second product stream **70** in an amount of less than 5 weight %, preferably less than 2 weight %, and even more preferably less than 1 weight %, based on the total weight of the second product stream **70**. In certain embodiments, methacrolein is present in the second product stream **70** in an amount of greater than 25 weight %, preferably greater than 35 weight %, and more preferably greater than 45 weight %, based on the total weight of the second product stream **70**. In certain embodiments, methanol is present in the second product stream **70** in an amount of greater than 25 weight %, preferably greater than 40 weight %, and more preferably greater than 55 weight %, based on the total weight of the second product stream **70**. The bottoms stream **51** contains amine-acid catalyst of the catalyst stream **10** that is recovered through the process of the invention. In certain embodiments, at least part of the bottoms stream **51** is recycled to the catalyst stream **10**, which in preferred embodiments is mixed in the catalyst tank **100**. The side draw stream **52** contains primarily water and certain organic compounds from the process. In certain embodiments, the side draw stream **52** contains methanol in an amount of less than 2 weight %, preferably less than 1.5 weight %, and more preferably less than 1 weight %.

Inhibitors can be introduced into the process through one or more locations, for example, the catalyst tank **100**, the reactor **200**, the phase separator **300**, the first distillation column **400**, the second distillation column **500**, the first product stream **60**, and the second product stream **70**. Suitable inhibitors include, for example, 4-hydroxy-2,2,6,6-tetramethylpiperidin-1-oxyl (4-Hydroxy-TEMPO).

In certain embodiments, the propionaldehyde in the reaction stream **10** is prepared by the hydroformylation of ethylene. The hydroformylation process is known in the art, for example, as described in U.S. Patent No. 4,427,486, U.S. Patent No. 5,087,763, U.S. Patent No. 4,716,250, U.S. Patent No. 4,731,486, and U.S. Patent No. 5,288,916. The hydroformylation of ethylene to  
5 propionaldehyde involves contacting ethylene with CO and hydrogen in the presence of a hydroformylation catalyst. Suitable hydroformylation catalysts include, for example, metal-organophosphorous ligand complexes. Suitable organophosphorous ligands include, for example, organophosphines, organophosphites, and organophosphoramidites. In certain  
10 embodiments, the ratio of CO to hydrogen is in the range of from 1:10 to 100:1, preferably of from 1:10 to 10:1. In certain embodiments, the hydroformylation reaction is conducted at a reaction temperature of from -25°C to 200°C, preferably of from 50°C to 120°C.

In certain embodiments, either or both of the first product stream **60** and second product stream **70** are utilized in a downstream oxidative esterification (“OER”) process. The OER process comprises contacting the methacrolein with methanol and an oxygen containing gas in  
15 the presence of an oxidative esterification catalyst under reaction conditions sufficient to produce methyl methacrylate. The OER process is known in the art, for example, as described in U.S. Patent No. 5,969,178, U.S. Patent No. 6,107,515, U.S. Patent No. 5,892,102, U.S. Patent No. 4,249,019, and U.S. Patent No. 4,518,796. In certain embodiments the methacrolein and methanol are supplied to the OER process by the first product stream **60**. In certain  
20 embodiments, the methacrolein and methanol are supplied to the OER process by the second product stream **70**. In certain embodiments the methacrolein and methanol are supplied to the OER process by the first product stream **60** and the second product stream **70**. The low amounts of water in each of the first product stream **60** and second product stream **70** makes each of the

streams particularly advantageous as a source feed for the OER process. Furthermore, the methanol recovered from the process in the second product stream **70** also makes it particularly advantageous as a source feed for the OER process. The molar ratio of methanol to methacrolein employed in the OER process is not particularly limited, and may be conducted over a wide  
5 range of molar ratios such as from 1:10 to 1,000:1, preferably from 1:1 to 10:1. Oxygen-containing gases that are suitable for the OER process include, for example, oxygen gas, or a mixed gas comprising oxygen gas and a diluent inert to the reaction (e.g., nitrogen, carbon dioxide, and the like). In certain embodiments, air may be utilized as a suitable oxygen-containing gas for the OER process. Suitable OER catalysts include, for example, palladium-  
10 based catalysts, gold-based catalysts, and intermetallics containing combinations of two or more metals. The catalytic elements may be supported on a carrier, for example, silica or alumina. In certain embodiments, the OER process is conducted at a reaction temperature of from 0°C to 120°C, preferably of from 40°C to 90°C.

Some embodiments of the invention will now be described in detail in the following  
15 Examples.

## **EXAMPLES**

### **Example 1**

#### ***Preparation of Methacrolein***

20 A static mixer 29" long and 0.1315" inner diameter was used as a reactor. Dimethyl amine, acetic acid and water were mixed in a catalyst mixing vessel from which the outlet flow was 550 g/h containing 4.5 weight % dimethyl amine and an amount of acetic acid sufficient to

maintain stream pH at 5.5. A stream comprising propionaldehyde and 37 weight % formaldehyde solution in water also containing 10-15% methanol (1:1 propionaldehyde:formaldehyde molar ratio) at a total flow of 1575 g/h was mixed with the aqueous catalyst solution and added to the reactor which was heated to 160°C and maintained at 5 900 psig. An inhibitor solution containing 8 weight % 4-Hydroxy-TEMPO in water was added to the reactor at a flow rate of 20 g/h. The reactor outlet was cooled to 25°C, depressurized to 1 atm and sent to a phase separator with an internal temperature of 7°C and pressure of 1 atm. The organic phase flow rate from the phase separator was 705 g/h and it contained 94 weight % methacrolein, 3.2 weight % water, and 1.6 weight % methanol. The organic phase was sent to a 10 distillation column with 22 trays wherein the distillate was sent to a downstream oxidative esterification process and the bottoms stream was sent to waste. An inhibitor solution containing 8 weight % 4-Hydroxy-TEMPO in methanol was added to the condenser of the distillation column at a flow rate of 10 g/h. The distillate consisted of 93 weight % methacrolein, 3.9 weight % water, 3.3 weight % methanol, and less than 0.2 weight % combined undesired impurities 15 (e.g., acetic acid, propionic acid, methacrolein dimer, and 2-methyl-2-pentenal). The bottoms stream flow rate from this column was 30 g/h. The aqueous phase contained 84 weight % water and was sent to a distillation column with 30 trays. The distillate flow from this column was 230 g/h consisting of 54 weight % methanol, 46 weight % methacrolein, and 0.1 weight % water, which was sent to a downstream oxidative esterification process. An inhibitor solution 20 containing 8 weight % 4-Hydroxy-TEMPO in methanol was added to the condenser of the distillation column at a flow rate of 8 g/h. The side-draw flow from the distillation column was 715 g/h comprising primarily water and 0.8 weight % methanol. An inhibitor solution containing 8 weight % 4-Hydroxy- TEMPO in methanol was added to the side-draw receiver of

the distillation column at a flow rate of 2 g/h. The bottoms stream from the distillation column contained primarily water and the recovered amine-acid catalyst. A fraction of 0.9 of the bottoms stream from the distillation column was recycled to the catalyst mixing vessel.

The example demonstrates that the process of this invention is effective at producing a  
5 methacrolein product stream with a low concentration of water, low concentration of undesired impurities, while also effectively capturing methanol contained in the formalin feedstock for use in a downstream oxidative esterification process to a level not previously achieved by the various methods of the prior art.

## WHAT IS CLAIMED IS:

1. A process for preparing methacrolein comprising:

- (a) mixing water and an amine-acid catalyst to provide a catalyst stream;
- (b) sending the catalyst stream and a reaction stream comprising propionaldehyde, formaldehyde, and methanol to a reactor to produce a first intermediate stream comprising methacrolein, methanol, and at least 8 weight % water;
- (c) providing the first intermediate stream to a phase separator to produce (i) an organic phase comprising (A) less than 4 weight % water, and (B) at least 70 weight % methacrolein, and (ii) an aqueous phase comprising methacrolein, methanol, amine-acid catalyst, and at least 70 weight % water, wherein the phase separator is operated at a temperature of less than 25°C;
- (d) distilling the organic phase in a first distillation column to produce (i) a first product stream comprising (A) methacrolein and methanol in a combined amount of at least 95 weight %, (B) less than 4 weight % water, and (C) less than 1 weight % of impurities comprising one or more of acetic acid, propionic acid, methacrolein dimer, and 2-methyl-2-pentenal, and (ii) a first waste stream;
- (e) distilling the aqueous phase in a second distillation column to produce (i) a second product stream comprising methacrolein, methanol, and less than 5 weight % water, (ii) a bottoms stream comprising amine-acid catalyst, and (iii) a side draw stream comprising water and less than 2 weight % methanol; and
- (h) recycling at least part of the bottoms stream to the catalyst stream.

2. The process of claim 1, wherein the propionaldehyde is produced by contacting ethylene with CO and H<sub>2</sub> in the presence of a hydroformylation catalyst.

3. The process of claim 1, further comprising providing at least part of the first product stream to a process comprising contacting the methacrolein with methanol and an oxygen-containing gas in the presence of an oxidative esterification catalyst to produce methyl methacrylate.
4. The process of claim 1, further comprising providing at least part of the second product stream to a process comprising contacting the methacrolein with methanol and an oxygen-containing gas in the presence of an oxidative esterification catalyst to produce methyl methacrylate.
5. The process of claim 1, further comprising providing at least part of the first product stream and at least part of the second product stream to a process comprising contacting the methacrolein with methanol and an oxygen-containing gas in the presence of an oxidative esterification catalyst to produce methyl methacrylate.
6. The process of claim 2, further comprising providing at least part of the first product stream and at least part of the second product stream to a process comprising contacting the methacrolein with methanol and an oxygen-containing gas in the presence of an oxidative esterification catalyst to produce methyl methacrylate.
7. The process of claim 1, wherein the organic phase comprises less than 10 weight % methanol.

8. The process of claim 1, wherein the phase separator is operated at a temperature of less than 5°C.

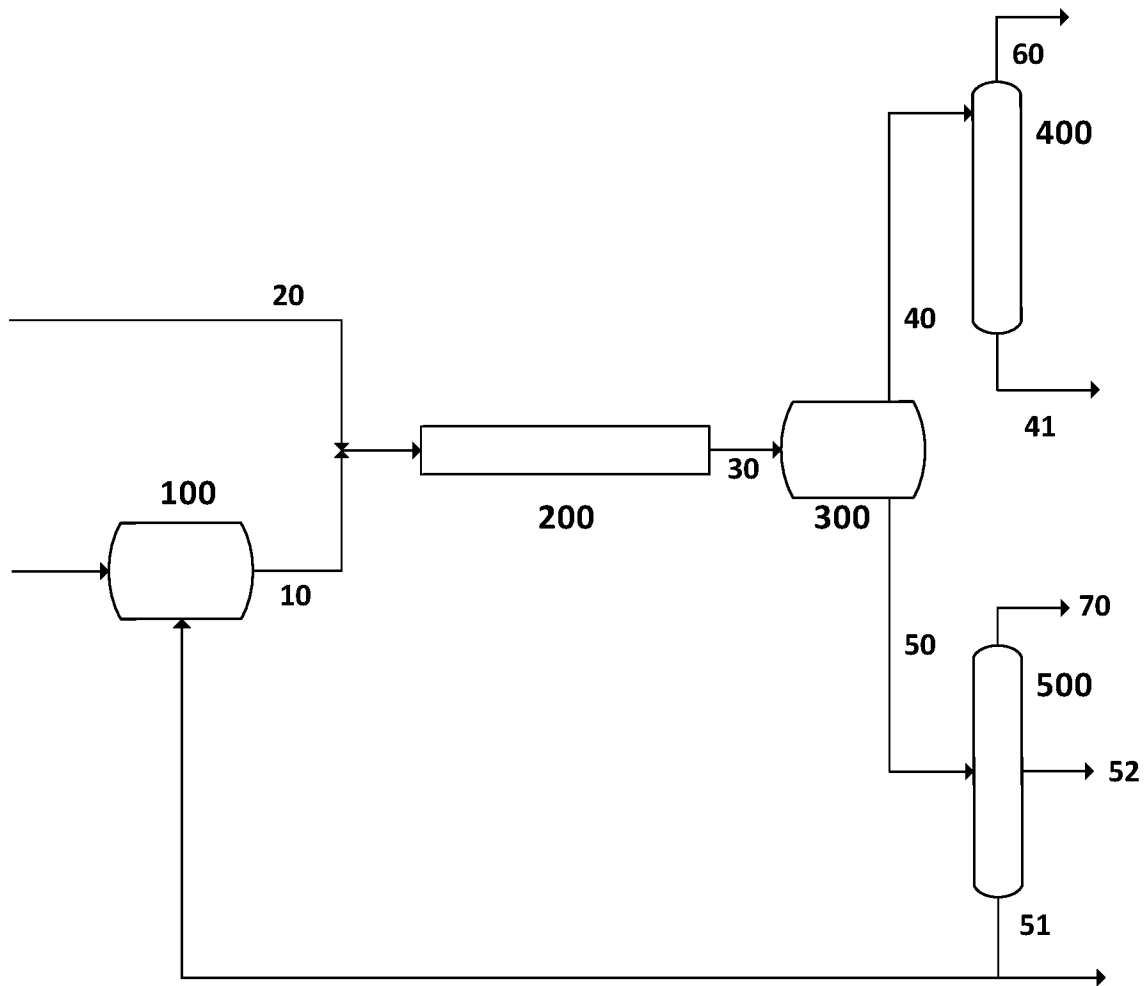

FIG. 1

**INTERNATIONAL SEARCH REPORT**

International application No  
PCT/US2018/034275

A. CLASSIFICATION OF SUBJECT MATTER  
 INV. C07C45/75 C07C45/78 C07C45/82 C07C47/22  
 ADD.  
 According to International Patent Classification (IPC) or to both national classification and IPC

B. FIELDS SEARCHED  
 Minimum documentation searched (classification system followed by classification symbols)  
 C07C  
 Documentation searched other than minimum documentation to the extent that such documents are included in the fields searched

Electronic data base consulted during the international search (name of data base and, where practicable, search terms used)  
 EPO-Internal, CHEM ABS Data, WPI Data

C. DOCUMENTS CONSIDERED TO BE RELEVANT		
Category*	Citation of document, with indication, where appropriate, of the relevant passages	Relevant to claim No.
A	US 2016/229779 A1 (HOY IV STACY W [US] ET AL) 11 August 2016 (2016-08-11) cited in the application paragraph [0052] - paragraph [0057]; example 1	1-8
A	US 2016/200660 A1 (KRILL STEFFEN [DE] ET AL) 14 July 2016 (2016-07-14) paragraph [0059] - paragraph [0065]; claim 1	1-8

Further documents are listed in the continuation of Box C.

See patent family annex.

\* Special categories of cited documents :

- "A" document defining the general state of the art which is not considered to be of particular relevance
- "E" earlier application or patent but published on or after the international filing date
- "L" document which may throw doubts on priority claim(s) or which is cited to establish the publication date of another citation or other special reason (as specified)
- "O" document referring to an oral disclosure, use, exhibition or other means
- "P" document published prior to the international filing date but later than the priority date claimed

- "T" later document published after the international filing date or priority date and not in conflict with the application but cited to understand the principle or theory underlying the invention
- "X" document of particular relevance; the claimed invention cannot be considered novel or cannot be considered to involve an inventive step when the document is taken alone
- "Y" document of particular relevance; the claimed invention cannot be considered to involve an inventive step when the document is combined with one or more other such documents, such combination being obvious to a person skilled in the art
- "&" document member of the same patent family

Date of the actual completion of the international search <b>24 August 2018</b>	Date of mailing of the international search report <b>11/09/2018</b>
--	---

Name and mailing address of the ISA/ European Patent Office, P.B. 5818 Patentlaan 2 NL - 2280 HV Rijswijk Tel. (+31-70) 340-2040, Fax: (+31-70) 340-3016	Authorized officer <b>Matés Valdivielso, J</b>
--	---

# INTERNATIONAL SEARCH REPORT

Information on patent family members

International application No

PCT/US2018/034275

Patent document cited in search report	Publication date	Patent family member(s)	Publication date	
US 2016229779	A1	11-08-2016	CA 2928807 A1	07-05-2015
			CN 105683142 A	15-06-2016
			EP 3063117 A1	07-09-2016
			JP 2016538259 A	08-12-2016
			KR 20160078367 A	04-07-2016
			SG 11201601819W A	30-05-2016
			TW 201536398 A	01-10-2015
			US 2016229779 A1	11-08-2016
			WO 2015065610 A1	07-05-2015
-----				
US 2016200660	A1	14-07-2016	BR 112016006509 A2	01-08-2017
			CN 105683148 A	15-06-2016
			EP 3049385 A1	03-08-2016
			JP 6355723 B2	11-07-2018
			JP 2016536277 A	24-11-2016
			KR 20160061395 A	31-05-2016
			RU 2016110762 A	28-09-2017
			SG 11201601069P A	30-03-2016
			US 2016200660 A1	14-07-2016
WO 2015043861 A1	02-04-2015			
-----				