

June 19, 1923.

1,459,031

T. F. MURPHY

MAIL BOX

Filed April 4, 1921

2 Sheets-Sheet 1

Fig. 1.



Thomas F. Murphy ^{Inventor}
By his Attorney
W. H. Humphrey

June 19, 1923.

1,459,031

T. F. MURPHY

MAIL BOX

Filed April 4, 1921

2 Sheets-Sheet 2

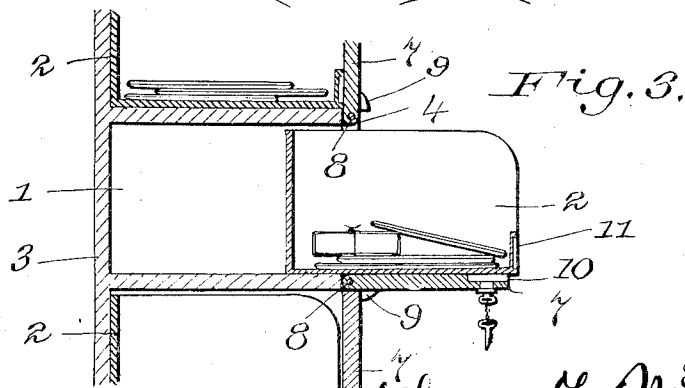
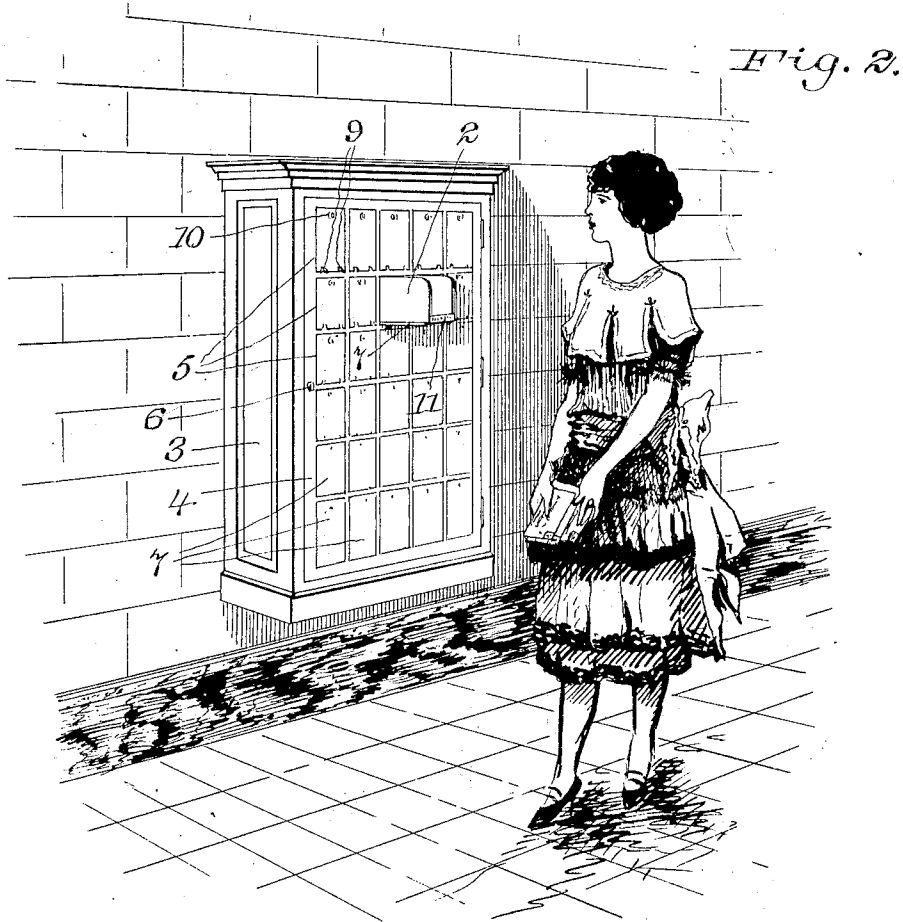

Inventor
Thomas F. Murphy
By his Attorney
W. H. Humphrey

UNITED STATES PATENT OFFICE.

THOMAS FRANCIS MURPHY, OF NEW YORK, N. Y., ASSIGNOR TO THE MAIL RECEPTACLE COMPANY, INC., OF NEW YORK, N. Y., A CORPORATION OF NEW YORK.

MAIL BOX.

Application filed April 4, 1921. Serial No. 453,386.

To all whom it may concern:

Be it known that I, THOMAS F. MURPHY, a citizen of the United States of America, residing at New York city, borough of Manhattan, State of New York, have invented certain new and useful Improvements in Mail Boxes, of which the following is a specification.

My invention relates particularly to the type of mail-box commonly used in apartment houses, in which a separate mail compartment is provided for each tenant; the compartments being arranged side by side, in one or a number of rows and either permanently set into a recess in the wall or enclosed in a suitable casing in the form of a portable cabinet.

This type of mail-box, now generally employed, is objectionable for many reasons:

The mail carrier is required to insert the mail one piece at a time, through a narrow slot in the door of each compartment. This method of delivery, in addition to being very slow and laborious, is unsatisfactory for the reason that frequently, owing to the difficulty of forcing the mail through the narrow slot, the ends of the containing envelopes are left sticking out, accessible to unauthorized persons who, from curiosity or more serious motives, may readily remove the same.

Another objection is the necessity, for the information and guidance of the mail carrier, of plainly marking each of the several compartments with the name of the tenants to whom they are assigned. This public display of the tenants' names results in their being harassed and annoyed by persons taking advantage of the information to communicate with them on various subjects.

Again, as usually located, the mail compartment must be opened and the presence of mail therein determined by the sense of touch, as it is ordinarily difficult, if not impossible to get a view of the interior, either by reason of the lack of light or the box being placed too low for convenient examination.

Having in mind the foregoing and other objections, I have produced a construction which not only meets and overcomes them but possesses many important advantages to be hereinafter pointed out.

The invention consists in a mail box, com-

prising a series of pigeon-holes mounted in a frame or other structure, a main door hinged to the frame or other structure and adapted to conceal all of said pigeon-holes, a series of openings in the main door corresponding with the pigeon-holes and coinciding with the openings of said pigeon-holes when the main door is closed, a series of smaller doors fitted to the openings in the main door and adapted to open and close access to the individual pigeon-holes, means for locking and unlocking the main and smaller doors, and a series of receptacles slidably fitted in said pigeon-holes and adapted to be withdrawn from the pigeon-holes through the openings in the main door when the main door is in closed and locked condition and the smaller doors are opened.

The invention also consists in the details of construction and combination of parts, all substantially as I will proceed now more fully to set forth and finally claim.

In the accompanying drawing, I have illustrated one form of mail-box suitable for carrying my invention into effect, but I do not wish to be understood as limiting myself to the same, as its employment here is for purposes of illustration only and it may be varied or departed from to any extent desired, within the scope of the claims.

In the drawing—

Fig. 1, is a perspective view of a mail-box of cabinet form, constructed in accordance with my invention and showing its use by the mail carrier, in the delivery of mail;

Fig. 2, is a similar view illustrating the manner of removing the mail by a box-holder, and

Fig. 3, is a detail sectional view.

Referring now to the drawings, 1 represents a series of "pigeon-holes", the number and arrangement of which may be varied in any manner desired, according to the conditions and requirements of each house, in which the mail box is installed.

The construction of the "pigeon-holes" is unimportant and may be the usual solid wood form or the metal skeleton form, being employed to serve only to support a corresponding series of mail containers 2, which as shown, are preferably thin sheet metal boxes, open at the top and front, and

proportioned to be easily moved in and out of the pigeon-hole.

This pigeon-hole case with its mail containers, may be set in a recess to come flush with the wall or it may, as illustrated, be enclosed in an open front cabinet 3, supported from either the floor or the wall.

Closing the open front of the cabinet there is preferably a main hinged door 4, in which opening 5 are formed, corresponding in number and arrangement and substantially coinciding in dimensions with the pigeon-holes and of a size suitable for permitting movement of the mail containers outward and inward through the said openings when the main door is closed and in locked condition.

The main door 4 is secured by a lock 6, the key to which is carried by the postman and under general adoption of the above described type of mail-box, this would be a master key common to the main door locks of all of the mail cabinets.

Closing each of the openings 5 in the main door 4, there is a small door 7, hinged at the bottom as indicated at 8, and to swing outwardly and provided with stop lugs 9, adapted to engage the front of the main door, to check and hold the small door from swinging downward below the horizontal, to afford a support for the receptacles when withdrawn from the pigeon-holes.

Each of the small doors is provided with a lock 10, the key to which is carried by the person to whom the box is assigned.

The small doors may be provided with a glass panel but are preferably solid, having only a small opening therein for the insertion of the key to the door lock.

In use, the postman, on arriving to deliver the mail, unlocks the main door 4 and swings it open, exposing the open front of the entire series of mail boxes or containers as illustrated in Fig. 1, and he then distributes the mail for the house, being guided in locating the boxes of the different tenants by labels or name plates secured on a bar 11, extending across the front of each box at or near the bottom thereof.

It will be observed that the postman is not in any way hampered or inconvenienced in the distribution and delivery of the mail, but on the contrary, is provided with the same "pigeon hole" type of case to which he is accustomed in handling mail in the post office.

The postman having completed the delivery of the mail, closes the main door of the cabinet, which is automatically secured by a "snap" lock, making it unnecessary for him to use his key.

The tenant or box-holder, coming along now for his mail, and being familiar with the location of his box or identifying it by the number of his key, unlocks the small

door of his box, which swings down to a horizontal plane and is there held by the stop lugs thereon. Reaching through the opening in the main door, he grasps the name bar on the front of his box and draws the box outward, as illustrated in Figs. 2 and 3, the small door serving as a support for the box. With the box in the position just described, any mail matter contained therein is not only fully exposed either through the open front or the open top but readily accessible for removal. In thus drawing the box outward through the door opening, the removal of the mail is not only greatly facilitated but the interior of the box is fully exposed to view in the full light of that portion of the building in which the cabinet is located, making it thereby improbable, if not impossible for a person to overlook small pieces of mail at the bottom of the box.

Having removed his mail, the tenant returns the box to proper position by pushing it inward into its pigeon hole and closes the small door, which, like the main cabinet door, is preferably locked by a snap lock, making it unnecessary to use the key. Having, therefore, described my invention, I claim:

1. A mail box, comprising a series of pigeon-holes and a frame or support therefor, a main door movably fixed to the frame or support, a series of openings in the main door corresponding with the pigeon-holes and coinciding with the openings therein when the main door is closed, a series of smaller doors for the openings in the main door and serving as closures for the pigeon-holes, means for locking and unlocking the main door and the individual smaller doors, a series of receptacles slidably fitted in said pigeon-holes and adapted to be withdrawn therefrom through the openings in the main door when the main door is in closed or locked condition and the smaller doors are opened, and means for supporting the smaller doors in horizontal position to afford a support for the receptacles when withdrawn from the pigeon-holes.

2. A mail box, comprising a series of pigeon-holes and a frame or support therefor, a main door movably fixed to the frame or support and adapted to conceal all of said pigeon-holes, a series of openings in the main door corresponding with the pigeon-holes and coinciding with the openings of said pigeon-holes when the main door is closed, a series of smaller doors hinged at their bottoms to the openings in the main door to swing outwardly to afford access to the individual pigeon-holes, means for locking and unlocking the main door and the individual smaller doors, a series of receptacles slidably fitted in said pigeon-holes and adapted to be withdrawn therefrom through the openings in the main door when the main

door is in closed and locked condition and the smaller doors are opened, and lugs on the smaller doors adapted to engage the main door to hold the smaller doors in horizontal position to afford a support for the receptacles when withdrawn from the pigeon holes.

In testimony whereof, I hereby affix my signature in the presence of two witnesses.

THOMAS FRANCIS MURPHY.

Witnesses:

H. A. DIXON,

G. A. McINTYRE.