

J. M. JOHNSON.  
BURGLAR AND FIRE ALARM SYSTEM.  
APPLICATION FILED OCT. 12, 1909.

993,688.

Patented May 30, 1911.

2 SHEETS—SHEET 1.

Fig. 1.

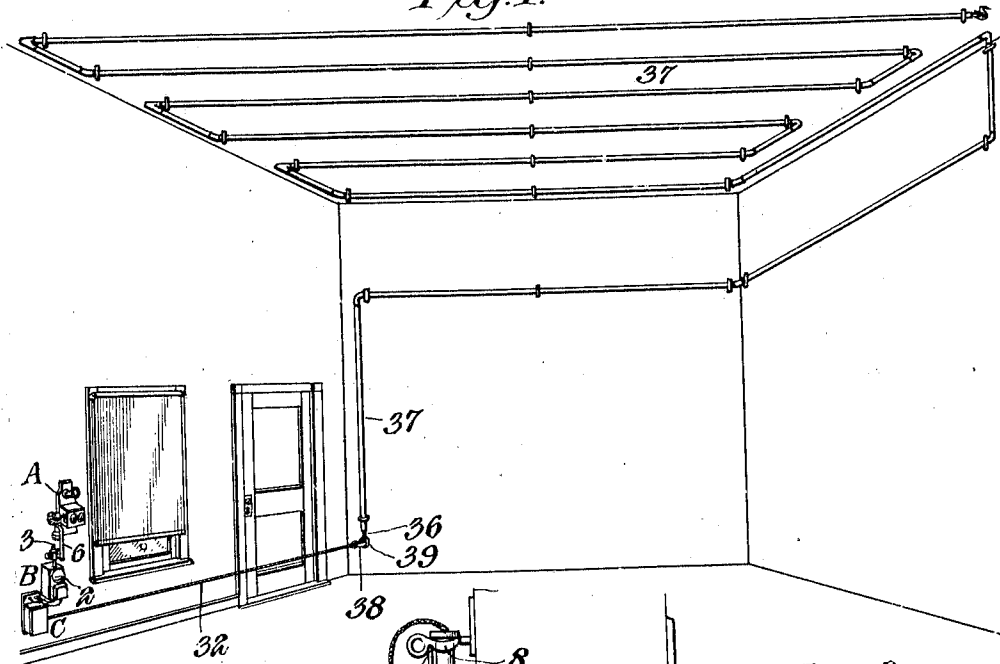

Fig. 2.

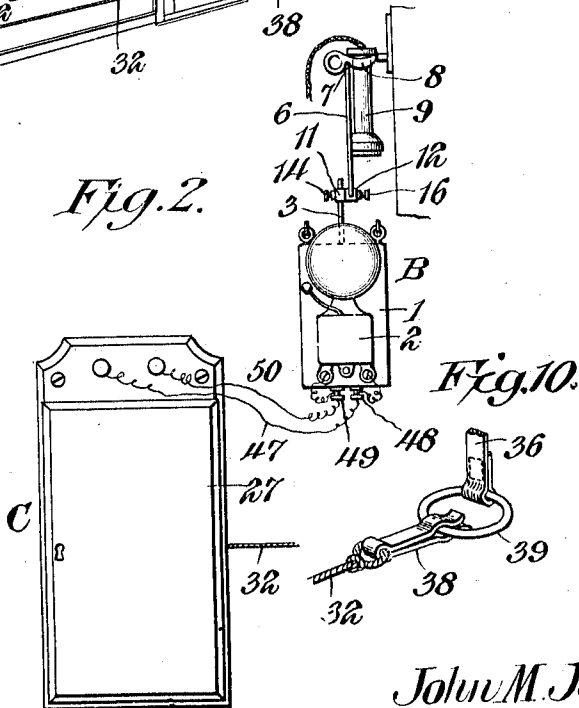
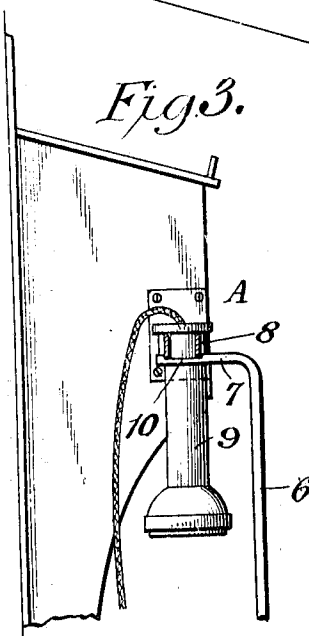

Fig. 3.



John M. Johnson, Inventor

Witnesses

Jas. E. McLaughlin  
C. Bradley.

By

E. J. Siggers  
Attorney

J. M. JOHNSON.  
BURGLAR AND FIRE ALARM SYSTEM.  
APPLICATION FILED OCT. 12, 1909.

993,688.

Patented May 30, 1911.

2 SHEETS—SHEET 2.

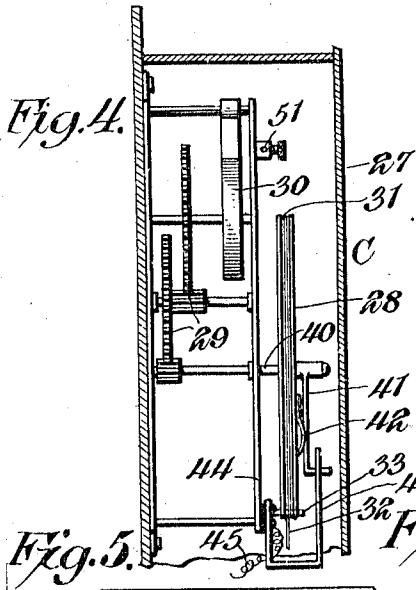
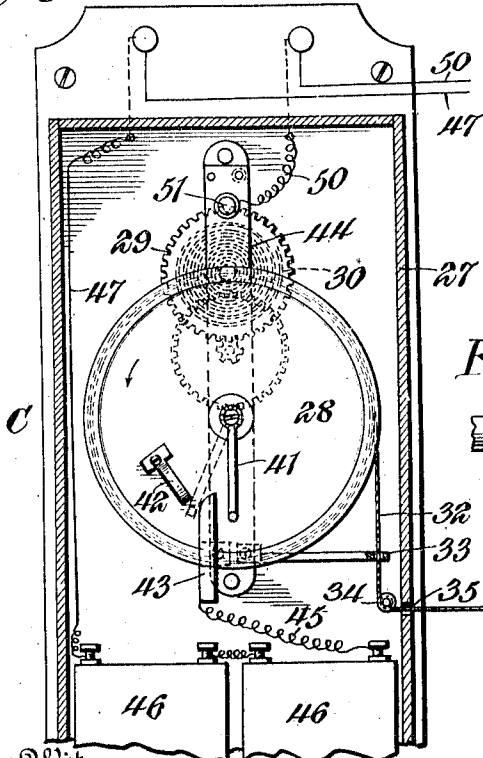

Fig. 5. Fig. 6.



Witnesses

Jas. E. McLaughlin  
C. Bradway.

Fig. 8.

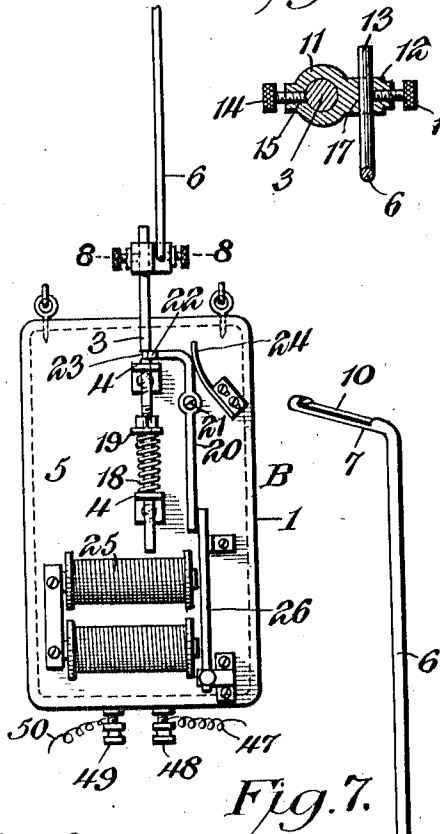
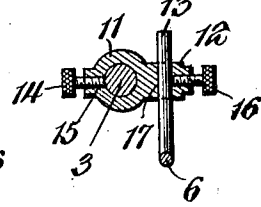
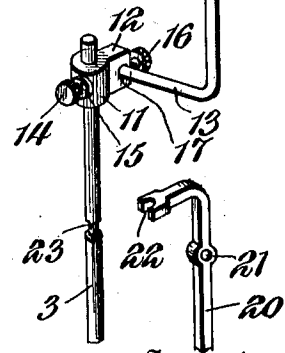
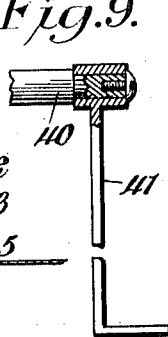

Fig. 7.

Fig. 9.



John M. Johnson, Inventor

By

E. G. Siggers

Attorney

# UNITED STATES PATENT OFFICE.

JOHN M. JOHNSON, OF BELLEVILLE, KANSAS.

BURGLAR AND FIRE ALARM SYSTEM.

993,688.

Specification of Letters Patent.

Patented May 30, 1911.

Application filed October 12, 1909. Serial No. 522,333.

To all whom it may concern:

Be it known that I, JOHN M. JOHNSON, a citizen of the United States, residing at Belleville, in the county of Republic and State of Kansas, have invented a new and useful Burglar and Fire Alarm System, of which the following is a specification.

This invention relates to a burglar and fire alarm system for the protection of dwelling houses and the like whereby a mechanism is set off by a burglar forcing a door or window open, or the flames, in case of a fire, burning a cord or equivalent element that holds the mechanism set.

The invention has for one of its objects to provide a novel system of this character which is of comparatively simple and inexpensive construction, reliable and efficient in use, and capable of being readily installed in a building to be protected.

A further object of the invention is the employment of an actuating mechanism released by fire or the entrance of a burglar, in connection with an ordinary telephone whereby the receiver fork will be raised when the mechanism is released to close the usual signal circuit for signaling to the central exchange operator, whereby the operator will be informed, by not receiving a response from the subscriber whose telephone switch has been closed, that either a fire has started in the subscriber's home or a burglar has entered, it being then the duty of the exchange operator to call up the police or fire department, or both, to investigate the trouble.

With these objects in view and others, as will appear as the description proceeds, the invention comprises the various novel features of construction and arrangement of parts which will be more fully described hereinafter and set forth with particularity in the claims appended hereto.

In the accompanying drawings, which illustrate one embodiment of the invention, Figure 1 is an interior perspective view of a room equipped with my improved burglar and fire alarm system. Fig. 2 is a front view of the actuating mechanism connected with a telephone. Fig. 3 is a detail view showing the means for raising the receiver fork of the telephone. Figs. 4 and 5 are sectional views of the controlling means for the telephone actuating device taken on different planes. Fig. 6 is an elevation of the tele-

phone fork actuating device. Fig. 7 is a perspective view of the lift rod for the telephone fork together with the trigger therefor. Fig. 8 is an enlarged section on line 8--8, Fig. 6. Fig. 9 is a detail view of the contact hand and of the said controlling means for closing the circuit of the telephone actuating device. Fig. 10 is a detail perspective view of means for detachably connecting the tension cord to a fusible element.

Similar reference characters are employed to designate corresponding parts throughout the views.

Referring to the drawings, A designates a subscriber's telephone set which may be of the wall or desk type and connected with the telephone company's lines of the immediate locality so that the exchange operator can be employed in protecting the subscribers' homes against fire or burglaries by informing the fire or police department whenever a telephone call is received from any subscriber's home and the operator is unable to receive a response in answer to calls, the operator being thereby made aware of the likelihood of a fire or an attempted burglary.

Associated with the telephone is an actuating mechanism, designated generally by B, which is set by the owner of the house each night before retiring or at any other time when the house is to be vacated, and this mechanism is under the control of a mechanism, designated generally by C, that is also set to operate in case of a fire or the opening of a door or window. The actuating mechanism B is located close to the telephone while the controlling mechanism may be at any remote point, it being connected with the actuating device by an electric circuit.

The actuating mechanism B comprises a casing 1 within which is arranged the means for raising the telephone fork or hook, and on the outside of the casing is an ordinary electric bell 2 for sounding an alarm to inform the occupants of the house that a fire has occurred or some one is attempting to enter. Arranged within the casing, the body of which is removed in Fig. 6, is a vertically-disposed lift rod 3 mounted in bearings 4 in the base plate 5 of the casing or box. On the upper end of this rod is carried a fork-engaging member 6 that has its upper end bent laterally into an arm 7 extending under the fork 8 that carries the receiver 9 of the

telephone A, the arm being recessed at 10 to receive the portion of the fork projecting beyond the receiver.

The member 6 is connected with the rod 3  
5 in any suitable manner to provide for properly adjusting the arm 7 to the receiver fork. In the present instance, this coupling consists of a sleeve 11 movable longitudinally  
10 of the rod 3 and having a laterally-extending lug 12 through which the lower laterally-bent arm 13 of the member 6 extends. The sleeve is clamped in place by a set screw 14 threaded in an opening 15, while  
15 the member 6 is secured in place by a set screw 16 threaded in the knob 12 and binding against the arm 13 which passes through an aperture 17 in the lug, as clearly shown  
20 in Fig. 8. By this means, the member 6 can be raised or lowered or moved laterally on the rod 3. The rod 3 is equipped with a spring 18 which bears against the lower bearing 4 and against an adjustable collar 19 on the rod so that the spring will urge  
25 the rod upwardly from set position. The rod is held in set position by a trigger 20 fulcrumed at 21 on the base plate 5 and formed with a bifurcated extremity 22 which engages a shoulder or projection  
30 formed by a recess 23 in the rod 3. The engaging end of the trigger or catch 20 is urged toward the rod 3 by a spring 24 mounted on the base plate 5 and bearing  
35 against the trigger. The trigger is released by an electro-magnet 25 carried by the base plate and having its armature 26 so arranged as to engage the lower end of the trigger to  
40 cause the bifurcated end thereof to disengage the rod 3 when the electro-magnet is energized. When the trigger is released, the rod 3 is raised, with the result that the receiver fork of the telephone is lifted to  
45 close the signal circuit leading to the central exchange.

The controlling mechanism C is arranged  
45 in a box or casing 27 which incloses a winding device and operating motor therefor. This winding device is in the form of a grooved wheel 28 that is rotated by a train  
50 of gears 29 and a spring 30, the gears and spring forming an ordinary clockwork mechanism. Arranged to wind in the peripheral groove 31 of the wheel 28 is a flexible  
55 wire or cord 32 which, when the device is set, prevents the wheel 28 from turning under the power of the clockwork mechanism. The flexible element 32 passes through a guide 33 and over a pulley 34  
60 and out of an opening 35 in the casing 27 to connect with a string, ribbon or other device that is destroyed by fire but which is of sufficient tensile strength to oppose the  
65 winding of the motor or clockwork mechanism while the apparatus is set. In the present instance, the cord 32, as shown in Fig. 1, is connected with a ribbon 36 of

celluloid or the like which may be incased  
by tubing 37 for protecting it against accidental injury. The tubing and ribbon or  
70 other suitable combustible device may be arranged in any desired manner in the building to be protected, so that in case of a fire in any part, the celluloid ribbon, string or  
75 the like will be destroyed and thus permit the cord 32 to wind on the wheel 28. The cord may be extended across a door or connected with a window so that in case of the opening of either, the cord will be released  
80 from the ribbon 36 and allowed to wind on the wheel. In order to permit the cord to be released by the opening of the door, a spring clip 38 is attached to the end of the cord to releasably engage a ring 39 on the  
85 celluloid ribbon 36, so that additional tension on the cord, as by the opening of the door, would disconnect the cord from the ribbon and set off the controlling mechanism and the actuating device of the telephone.

Mounted loosely on the arbor 40 of the  
90 wheel 28 is an L-shaped arm 41 which is adapted to be engaged by a projection 42 in the form of a spring on the wheel 28 so as to move the arm 41 into engagement with an electrical contact 43 carried by the frame  
95 44 of the clockwork mechanism. The projection or spring 42 thus carries the arm to the dotted line position, Fig. 5, but the wheel is permitted to continue its rotation until the cord 32 is wound, the spring 42  
100 yielding as it passes under the arm 41 while the latter is engaging the contact 43. When the winding of the cord 32 upon the wheel 28 is continued until the clip 38 engages a fixed member, as, for instance, the casing  
105 27 at the opening 35 therethrough, further rotation of the wheel under the impulse of the spring is prevented, and to this extent the cord may be said to be wound upon the  
110 wheel. The contact is connected by a wire 45 with the cells 46 in the box 27, and the cells are, in turn, connected by a wire 47 with the binding post 48 of the electromagnet 25, while the other binding post 49 of  
115 the electro-magnet is connected by a wire 50 with a binding post 51 on the frame 44 of the clockwork mechanism, whereby the arbor 40 and arm 41 are connected in circuit. It will thus be seen that when the arm  
120 41 is in the dotted line position, Fig. 5, the electro-magnet 25 will be energized to release the trigger of the telephone fork lifting device, and consequently the telephone circuit will be closed to inform the exchange  
125 operator that a fire has broken out or burglary is attempted at the place where the telephone is located. The electric bell 2 is connected with the binding posts 48 and 49 so as to be simultaneously actuated with the  
130 electro-magnet 25.

In setting the device, it is merely necessary to press downwardly on the upper end of

the rod 3 to permit the trigger to automatically lock the rod in depressed position against the tension of the spring 18, the contact arm 41 of the circuit-controlling mechanism being placed in the full line position, Fig. 5, and the cord 32 being connected with the combustible ribbon or string 36, as shown in Fig. 1. While the device is thus set, it will be automatically operated either in case of fire or upon an attempt to effect an entry to the house.

From the foregoing description, taken in connection with the accompanying drawings, the advantages of the construction and of the method of operation will be readily apparent to those skilled in the art to which the invention appertains, and while I have described the principle of operation of the invention, together with the apparatus which I now consider to be the best embodiment thereof, I desire to have it understood that the apparatus shown is merely illustrative, and that such changes may be made when desired as are within the scope of the claims appended hereto.

Having thus described the invention, what I claim as new, and desire to secure by Letters Patent, is:—

1. An alarm apparatus comprising a rotatable member, power means for actuating said rotatable member, a strand connected to the rotatable member and constituting means for holding the latter against the action of the power means, a connector carried by the free end of the strand, a holding means for the connector from which said connector is adapted to be released by a suitable force applied to the strand, a fixed means adjacent to the rotatable member and in the path of the connector for arresting the movement of the strand toward the rotatable member by engaging said connector, electric circuit terminals, means on the rotatable member for causing engagement of said circuit terminals, and signal means controlled by said circuit terminals.

2. In an alarm apparatus, a rotatable drum, a flexible strand connected thereto for winding thereon, a strand responsive to a predetermined degree of heat to have its continuity broken, readily separable connections between said strands, a casing for the drum through which the first named strand extends and to which the readily separable

connection is moved by the winding of the first named strand on the drum, power means within the casing for actuating the drum and held against action by the first named strand and its connection to the second named strand, and signal means controlled by the rotatable drum.

3. In an alarm apparatus, a rotatable member, power means for rotating the same, a strand connected to the rotatable member and constituting means for holding the rotatable member against the action of the power means, electric circuit terminals one of which is fixed and the other movable, and an elastic member carried by the rotatable member in position to engage the movable terminal to carry the same into engagement with the other terminal, said elastic member then yielding on further rotative movement of the rotatable member.

4. In an alarm apparatus, a power actuated member, circuit terminals controlled thereby, an electric signal means controlled by the circuit terminals, a strand connected to the power actuated member for holding the same against movement, another strand responsive to predetermined heat conditions, and readily separable connections between the two strands whereby the second strand acts in conjunction with the first strand to hold the power actuated member against movement.

5. In an alarm apparatus, a spring actuated wheel, a tension member holding the wheel normally at rest, an element responsive to predetermined heat conditions and connected to said tension member, a fixed circuit terminal, a loosely mounted circuit terminal, and an elastic member on the spring actuated wheel movable by the latter into engagement with the loosely mounted circuit terminal to move the latter into engagement with the fixed circuit terminal and then yieldable to escape from the circuit terminal actuated thereby, and signal means in circuit with the circuit terminals.

In testimony, that I claim the foregoing as my own, I have hereto affixed my signature in the presence of two witnesses.

JOHN M. JOHNSON.

Witnesses:

W. G. MALL,  
N. WHITNEY.