

(19) World Intellectual Property Organization
International Bureau



(43) International Publication Date
19 June 2003 (19.06.2003)

PCT

(10) International Publication Number
WO 03/051066 A2

- (51) International Patent Classification⁷: **H04Q 3/00** Brighton BN29TN, ENGLAND (US). **LINDQUIST, Jan**;
1313 San Mateo Drive, Allen, TX 75013 (US).
- (21) International Application Number: PCT/US02/38950
- (22) International Filing Date: 5 December 2002 (05.12.2002)
- (25) Filing Language: English
- (26) Publication Language: English
- (30) Priority Data:
10/010,832 6 December 2001 (06.12.2001) US
- (71) Applicant: **ERICSSON INC.** [US/US]; 6300 Legacy,
Plano, Texas 75024 (US).
- (72) Inventors: **SCOTT, Stacy**; 1221 Aylesbury Drive, Allen,
TX 75002 (US). **FRANCIS, Herbie**; 24 Hampden Road,
- (74) Agent: **WEATHERFORD, Sidney**; Ericsson Inc., 6300
Legacy, MSEVW2-C-2, Plano, TX 75024 (US).
- (81) Designated States (*national*): AE, AG, AL, AM, AT, AU,
AZ, BA, BB, BG, BR, BY, BZ, CA, CH, CN, CO, CR, CU,
CZ, DE, DK, DM, DZ, EC, EE, ES, FI, GB, GD, GE, GH,
GM, HR, HU, ID, IL, IN, IS, JP, KE, KG, KP, KR, KZ, LC,
LK, LR, LS, LT, LU, LV, MA, MD, MG, MK, MN, MW,
MX, MZ, NO, NZ, OM, PH, PL, PT, RO, RU, SC, SD, SE,
SG, SK, SL, TJ, TM, TN, TR, TT, TZ, UA, UG, UZ, VC,
VN, YU, ZA, ZM, ZW.
- (84) Designated States (*regional*): ARIPO patent (GH, GM,
KE, LS, MW, MZ, SD, SL, SZ, TZ, UG, ZM, ZW),
Eurasian patent (AM, AZ, BY, KG, KZ, MD, RU, TJ, TM),
European patent (AT, BE, BG, CH, CY, CZ, DE, DK, EE,

[Continued on next page]

(54) Title: COMBINING NARROWBAND APPLICATIONS WITH BROADBAND TRANSPORT

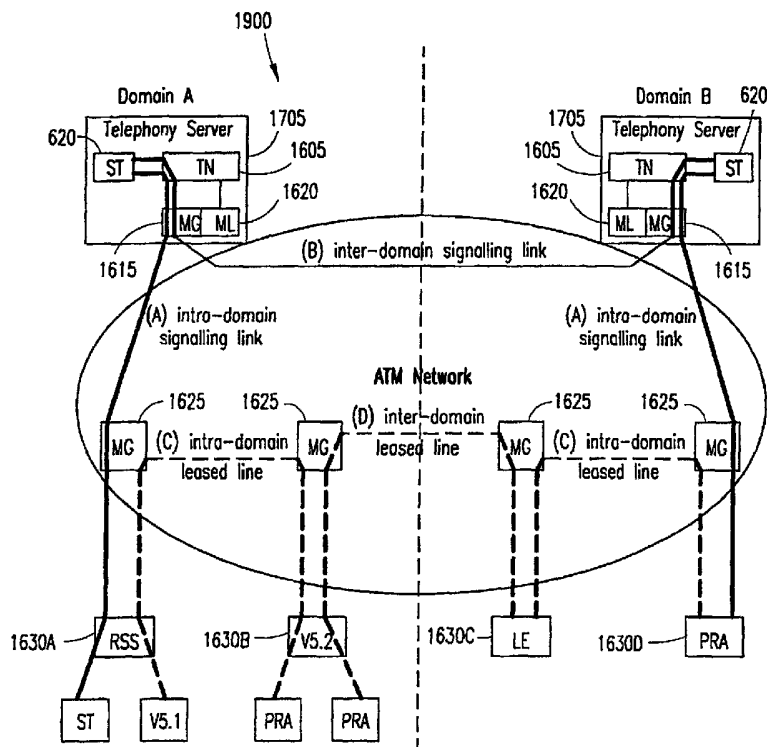

- The part of a signalling link configured by TN commands (A)
- The part of a signalling link configured by ATM Management System (B)
- - - The part of a signalling line configured by TN commands
- - - The part of a leased line configured by ATM Management System (C) & (D)

(57) Abstract: The combination of narrowband applications with broadband transport may be enabled with a tri-level nodal communications architecture including multiple call control nodes, multiple connection control nodes and one or more intermediate node for interworking between the call control nodes and connection control nodes, in which the intermediate node(s) are controlled by all of the call control nodes. In certain embodiment(s), the identity of the call control node is transmitted to the intermediate node with each message to differentiate between the multiple call control nodes. In addition, each resource (e.g., port) managed by the intermediate node has a call control node identity associated therewith. In further embodiments, a logical port is used to support connections between call control nodes sharing the same intermediate node. The logical port represents a logical E 1 path between the two call control nodes.

WO 03/051066 A2



ES, FI, FR, GB, GR, IE, IT, LU, MC, NL, PT, SE, SI, SK, TR), OAPI patent (BF, BJ, CF, CG, CI, CM, GA, GN, GQ, GW, ML, MR, NE, SN, TD, TG).

Published:

— *without international search report and to be republished upon receipt of that report*

Declarations under Rule 4.17:

- *as to applicant's entitlement to apply for and be granted a patent (Rule 4.17(ii)) for all designations*
- *as to the applicant's entitlement to claim the priority of the earlier application (Rule 4.17(iii)) for all designations*

For two-letter codes and other abbreviations, refer to the "Guidance Notes on Codes and Abbreviations" appearing at the beginning of each regular issue of the PCT Gazette.

**COMBINING NARROWBAND APPLICATIONS
WITH BROADBAND TRANSPORT**

CROSS-REFERENCES TO RELATED APPLICATIONS

5 This U.S. Nonprovisional Application for Patent is a Continuation-in-Part of U.S. Nonprovisional Application for Patent Serial No. 09/764,953, which was filed on January 17, 2001. U.S. Nonprovisional Application for Patent Serial No. 09/764,953 is also hereby incorporated by reference in its entirety herein.

10 This U.S. Nonprovisional Application for Patent is related by subject matter to U.S. Nonprovisional Applications for Patent Serial Nos. 10/025354 filed December 18, 2001, 10/029361 filed December 21, 2001, 10/021940 filed December 12, 2001, and 10/028176 filed December 21, 2001. These U.S. Nonprovisional Applications for Patent Serial Nos. 10/025354, 10/029361, 10/021940, and 10/028176 are hereby incorporated by reference in their entirety herein.

15 **BACKGROUND OF THE INVENTION**

Technical Field of the Invention

20 The present invention relates in general to the field of communications, and in particular, by way of example but not limitation, to using broadband transport for narrowband telephony and data communications.

Description of Related Art

25 The increasing interest for high band services such as multimedia applications, video on demand, video telephone, and teleconferencing has motivated development of the Broadband Integrated Service Digital Network (B-ISDN). B-ISDN is based on a technology known as Asynchronous Transfer Mode (ATM) and offers considerable extension of telecommunications capabilities.

30 ATM is a packet-oriented transfer mode which uses asynchronous time division multiplexing techniques. The packets are called cells and traditionally have a fixed size. A standard ATM cell comprises 53 octets, five of which form a header and 48 of which constitute a "payload" or information portion of the cell. The header of the ATM cell includes two quantities that are used to identify a connection in an ATM network over which the cell is to travel. These two quantities include

-2-

the Virtual Path Identifier (VPI) and the Virtual Channel Identifier (VCI). In general, a virtual path is a principal path defined between two switching nodes of the network; a virtual channel is one specific connection on the respective principal path.

At its termination points, an ATM network is connected to terminal equipment, e.g., ATM
5 network users. In between ATM network termination points, there are typically multiple switching nodes. The switching nodes have ports which are connected together by physical transmission paths or links. Thus, in traveling from an originating terminal equipment to a destination terminal equipment, ATM cells forming a message may travel through several switching nodes and the ports thereof.

10 Of the multiple ports of a given switching node, each may be connected via a link circuit and a link to another node. The link circuit performs packaging of the cells according to the particular protocol in use on the link. A cell that is incoming to a switching node may enter the switching node at a first port and exit from a second port via a link circuit onto a link connected to another node. Each link can carry cells for multiple connections, with each connection being, e.g., a transmission between
15 a calling subscriber or party and a called subscriber or party.

The switching nodes each typically have several functional parts, a primary of which is a switch core. The switch core essentially functions like a cross-connect between ports of the switch. Paths internal to the switch core are selectively controlled so that particular ports of the switch are connected together to allow a message to travel from an ingress side/port of the switch to an egress
20 side/port of the switch. The message can therefore ultimately travel from the originating terminal equipment to the destination terminal equipment.

While ATM, because of the high speed and bandwidth that it offers, is envisioned as the transport mechanism for more advanced services such as B-ISDN, it nevertheless must be recognized that the current narrowband networks (e.g., Public Switched Telephone Networks (PSTN), ISDN, etc.)
25 will remain in use (at least in part) for quite some time. It has taken decades for the present voice switched telephony networks (e.g., PSTN, ISDN, etc.) to reach their present advanced functionalities. While ATM networks are being built, the ATM networks will likely not easily acquire all the functionalities of advanced voice communication. Therefore, at least initially, ATM networks/nodes will in some instances be added to parts or will replace parts of circuit switched telephony networks.
30 In such instances, ATM will be used for transport and switching. ATM can actually be used as a single transport and switching mechanism for multiple other networks, including multiple other different types of networks. For example, a single ATM network can be used to transport and switch

communications from mobile networks (e.g., Public Land Mobile Networks (PLMNs)), Internet protocol (IP)-based networks (e.g., the Internet), etc., as well as landline networks such as PSTNs and ISDNs.

5 United States Patent Nos. 5,568,475 and 5,483,527 to Doshi et al., for example, incorporate ATM switches for routing telephony voice signals between Synchronous Transfer Mode (STM) nodes. The ATM switches use a signaling system No. 7 (SS#7) network to establish a virtual connection, rather than a circuit switched connection, as would be the case in a pure STM network. The signaling system No. 7 (SS#7) network of United States Patents 5,568,475 and 5,483,527 includes signal transfer points (STPs) that are connected by special physical links to each of the ATM switch nodes.
10 For call setup, for example, signaling messages are relayed through the signaling system No. 7 (SS#7) network. In such relaying, a non-ATM STP receives the signaling message and advises its associated ATM node of the call setup. The associated ATM node may then identify idle resources to be used for forwarding voice signals to the next ATM node once the call has been setup, and it may prepare its own signaling message to be used in the relay.

15 The signaling message for the relay that is prepared by the ATM node is returned to its associated STP, which forwards the signaling message via the signaling system No. 7 (SS#7) network to another STP associated with the next ATM node. Such relaying continues until the signaling message reaches an STP of an STM local exchange carrier (LEC). Once the call has been set up, the ensuing speech (or voice-band data) is transported via the ATM nodes. STM/ATM terminal adapters
20 are situated between the STM network and the ATM network for packing samples of voice signals as received from the STM network into ATM cells for application to the ATM network, and for unpacking ATM cell payloads to obtain voice signals for application to the STM network from the ATM network. The incorporation of ATM into an STM network in the particular manner as described above thus involves a non-ATM signaling network alongside the ATM nodes. Furthermore, each STP
25 node associated with an ATM node performs only call control functions in the network of Doshi et al. Otherwise and in general, call control and connection control is traditionally combined in conventional communication nodes.

With reference now to FIG. 1A, a conventional unified communications node is illustrated at 100. The conventional unified communications node 100 may represent any general purpose
30 switching node in a telecommunications network such as a PSTN. Within the conventional communications node 100, the call control 105 functions and the connection control 110 functions are united. The call control 105 and the connection control 110 functions together encompass the entire

seven (7) layers of the Open System Interconnection (OSI) protocol. These seven (7) layers are denoted as the physical, data link, network, transport, session, presentation, and application layers. Accordingly, the conventional communications node 100 may perform all functions related to both switching intelligence and switching fabric. Conventional communication nodes 100 are not, however, capable of handling the interworking between (i) narrowband telephony and data communications and (ii) broadband communications using faster and higher bandwidth networks, such as ATM networks.

With reference now to FIG. 1B, a conventional approach to separating functions of the conventional unified communications node of FIG. 1A is illustrated generally at 150. Conventional approaches attempt to meet the stringent demands of interworking narrowband telephony and data communications with broadband networks using ATM by separating control functions. Specifically, call control 155 functions are separated from connection control 160 functions. The call control 155 functions are thereby made independent of any particular set of connection control 160 functions. This separation is typically accomplished by utilizing a conventional communications node (such as the conventional communications node 100 of FIG. 1A) that is stripped of its switching intelligence, leaving only the connection control 160. In effect, a conventional communications node 100 is modified by removing or rendering inoperative the call control 105 functions, thus leaving only the connection control 110 functions. This modified conventional communications node is substituted as the connection control 160 part. The call control 155 part, on the other hand, is typically designed and created without relying on traditional telecommunications hardware or software.

With reference now to FIG. 2, an existing scheme for utilizing a broadband network in conjunction with nodes corresponding to separated functions of a conventional unified communications node is illustrated generally at 200. Switching intelligence 205A,205B parts are connected to switching fabric 210A,210B parts. The switching fabric 210A,210B parts are connected to the ATM network 215, and they effect required emulation and cell packing for interworking a narrowband network (not shown) with the ATM network 215. The switching intelligence 205A,205B parts are usually realized with a UNIX-based server. The switching intelligence 205A,205B parts are intended to provide the advanced calling services and features (e.g., those traditionally provided by the Intelligence Network (IN)). The switching intelligence 205A,205B parts do not include any switching fabric resources, so they must rely on the switching fabric 210A,210B parts for these resources. Because the switching intelligence 205A,205B parts do not have any of their own switching fabric resources, they are not directly connected to any transport mechanisms, nor do they include the

requisite interface(s) for doing so. Incoming calls are therefore received at a switching fabric 210 part and managed by the associated switching intelligence 205 part. When an incoming call is received at a switching fabric 210 part, call signaling information is sent to the switching intelligence 205 part. The switching intelligence 205 part performs the appropriate call control functions and sends instructions (e.g., in the form of call signaling information) to the switching fabric 210 part. The switching fabric 210 part follows the instructions by making the appropriate connections (e.g., to/through the ATM network 215, to/through a narrowband network (not shown), etc.) for forwarding the call data information for the incoming call. As such, no call data information is (or can be) sent to the switching intelligence 205 part, including from the switching fabric 210 part.

Furthermore, while UNIX-based servers, which realize the switching intelligence 205 parts, may be designed to operate at high speeds, they suffer from a number of deficiencies. First, significant research, design, and testing is required to produce appropriate software code to run the UNIX-based servers as switching intelligence 205 parts. Existing circuit-switched voice telephony networks include many advanced features that require many lines of code that have been gradually developed, tested, and implemented over many years. Duplicating the diverse number and types of features while maintaining the required level of reliability and service using newly written code on a UNIX server is not only a daunting task, but it is also virtually impossible to achieve quickly. Second, it is extraordinarily difficult to migrate gradually from traditional network architectures (e.g., those using the conventional unified communications node 100 of FIG. 1A) to next generation networks that rely on broadband transport mechanisms when deploying nodes with only the switching intelligence 205 part. System operators are essentially forced to simultaneously replace whole portions of their networks in large chunks. The consequential large capital expenditures are naturally undesirable to system operators.

SUMMARY OF THE INVENTION

The deficiencies of the prior art are overcome by the methods, systems, and arrangements of the present invention. For example, as heretofore unrecognized, it would be beneficial to re-use and/or extend the life of existing/legacy switches when combining narrowband networks with broadband transport mechanisms. In fact, it would be beneficial to utilize existing switches to enable a gradual migration from narrowband networks to broadband transport mechanisms via the implementation of hybrid switches.

The present invention is directed to a tri-level nodal communications architecture including multiple call control nodes, multiple connection control nodes and one or more intermediate node for interworking between the call control nodes and connection control nodes, in which the intermediate node(s) are controlled by all of the call control nodes. Each of the call control nodes includes both
5 switching intelligence and narrowband switching fabric, and each of the connection control nodes includes broadband switching fabric.

In certain embodiment(s), the identity of the call control node is transmitted to the intermediate node with each message to differentiate between the multiple call control nodes. In addition, each resource (e.g., port) managed by the intermediate node has a call control node identity
10 associated therewith. In further embodiments, a logical port is used to support connections between call control nodes sharing the same intermediate node. The logical port represents a logical E1 path between the two call control nodes.

Advantageously, using multiple call control nodes provides additional call handling capacity and supports greater amounts of Intelligent Network (IN) traffic. The above-described and other
15 features of the present invention are explained in detail hereinafter with reference to the illustrative examples shown in the accompanying drawings. Those skilled in the art will appreciate that the described embodiments are provided for purposes of illustration and understanding and that numerous equivalent embodiments are contemplated herein.

20 **BRIEF DESCRIPTION OF THE DRAWINGS**

A more complete understanding of the methods, systems, and arrangements of the present invention may be had by reference to the following detailed description when taken in conjunction with the accompanying drawings wherein:

FIG. 1A illustrates a conventional unified communications node;

25 FIG. 1B illustrates a conventional approach to separating functions of the conventional unified communications node of FIG. 1A;

FIG. 2 illustrates an existing scheme for utilizing a broadband network in conjunction with nodes corresponding to separated functions of a conventional unified communications node;

30 FIG. 3 illustrates an exemplary schematic view of a hybrid STM/ATM network according to an embodiment of the invention;

FIG. 3A illustrates an exemplary schematic view of selected portions of the hybrid STM/ATM network of FIG. 3, and further showing various operational events;

FIG. 3B illustrates an exemplary schematic view of a hybrid STM/ATM network according to another embodiment of the invention;

FIG. 3C illustrates an exemplary schematic view showing a transit hybrid node pair of the invention connected between two local exchange hybrid node pairs of the invention;

5 FIG. 3D illustrates a diagrammatic view of an exemplary protocol between two elements of the network of the embodiment(s) of the invention that include hybrid node pairs;

FIGS. 3E, 3F, and 3G illustrate diagrammatic views of alternate exemplary protocols between two elements, a first of the network elements having a hybrid node pair in accordance with embodiment(s) of the invention and a second of the network elements being an access node with an additional ATM interface having circuit emulation;

10 FIG. 3H illustrates an exemplary diagrammatic view showing gradual upgrading of a network from a traditional narrowband STM-transported-and-switched environment into an environment with a hybrid STM/ATM network in accordance with embodiment(s) of the invention;

FIG. 3I illustrates an exemplary schematic view showing a multi-switch hybrid node according to yet another embodiment of the invention;

15 FIG. 4 illustrates another exemplary scheme for utilizing a broadband network in conjunction with nodes having partially separated functions in accordance with the present invention;

FIG. 5 illustrates yet another exemplary scheme for utilizing a broadband network in conjunction with nodes having partially separated functions in accordance with the present invention;

20 FIG. 6 illustrates another exemplary hybrid switch with multiple ports for switching a connection in accordance with the present invention;

FIG. 7 illustrates a simplified block diagram of an exemplary hybrid switch in accordance with the present invention;

25 FIG. 8 illustrates exemplary communications and connections between nodes in another simplified block diagram of an exemplary hybrid switch in accordance with the present invention;

FIG. 9 illustrates an exemplary method in flowchart form for communicating between nodes in a hybrid switch in accordance with the present invention;

FIGS. 10A-10E illustrate a first set of exemplary traffic scenarios for a hybrid switch in accordance with the present invention;

30 FIGS. 10F-10K illustrate a second set of exemplary traffic scenarios for a hybrid switch in accordance with the present invention;

FIG. 11 illustrates an exemplary outgoing communication format selection for a hybrid switch in accordance with the present invention;

FIG. 12 illustrates exemplary interactions between a hybrid switch and other telecommunications technology in accordance with the present invention;

5 FIG. 13 illustrates an exemplary traffic scenario migration for a hybrid switch in accordance with the present invention;

FIG. 14 illustrates an exemplary method in flowchart form for enabling a gradual migration from a primarily narrowband network to a primarily broadband network in accordance with the present invention;

10 FIG. 15 illustrates an exemplary tri-level nodal environment in accordance with the present invention;

FIG. 15A illustrates a first exemplary tri-level nodal environment alternative in accordance with the present invention;

15 FIG. 15B illustrates a second exemplary tri-level nodal environment alternative in accordance with the present invention;

FIG. 15C illustrates an exemplary interworking function in accordance with the present invention;

FIG. 16 illustrates an exemplary tri-level nodal environment implementation in accordance with the present invention;

20 FIGS. 17A and 17B illustrate two other exemplary tri-level nodal environment implementations in accordance with the present invention;

FIGS. 18A and 18B illustrate two exemplary call setups in an exemplary tri-level nodal environment implementation in accordance with the present invention;

25 FIG. 19 illustrates exemplary communication path configuring in an exemplary tri-level nodal network in accordance with the present invention;

FIGS. 20A and 20B illustrate exemplary mapping embodiments in an exemplary tri-level nodal environment implementation in accordance with the present invention;

FIG. 21 illustrates an exemplary tri-level nodal environment with multiple call control nodes controlling one or more intermediate nodes in accordance with the present invention;

30 FIG. 22 illustrates exemplary message handling between an intermediate node and multiple call control nodes in accordance with the present invention;

FIGs. 23A and 23B illustrate exemplary mapping embodiments in the exemplary tri-level nodal environment of FIG. 21 in accordance with the present invention;

FIG. 24 illustrates an exemplary method in flowchart form for mapping between address spaces in the tri-level nodal environment of FIG. 21 in accordance with the present invention;

5 FIG. 25 illustrates a further exemplary mapping embodiment in the exemplary tri-level nodal environment of FIG. 21 in accordance with the present invention;

FIG. 26 illustrates an exemplary connection between call control nodes within the tri-level nodal environment of FIG. 21 in accordance with the present invention; and

10 FIG. 27 illustrates an exemplary method in flowchart form for establishing a connection between call control nodes in the tri-level nodal environment of FIG. 21 in accordance with the present invention.

DETAILED DESCRIPTION OF THE DRAWINGS

15 In the following description, for purposes of explanation and not limitation, specific details are set forth, such as particular architectures, interfaces, circuits, information exchanges, logic modules (implemented in, for example, software, hardware, firmware, some combination thereof, etc.), techniques, etc. in order to provide a thorough understanding of the invention. However, it will be apparent to one of ordinary skill in the art that the present invention may be practiced in other embodiments that depart from these specific details. In other instances, detailed descriptions of well-

20 known methods, devices, logical code (e.g., hardware, software, firmware, etc.), etc. are omitted so as not to obscure the description of the present invention with unnecessary detail. It should be understood that the terms "module" and "logic module" as used herein embrace, subsume, and include, inter alia, object oriented programming techniques as well as so-called traditional programming techniques such as, for example, custom-developed applications.

25 Embodiment(s) of the present invention and advantages thereof are best understood by referring to FIGS. 1A-27 of the drawings, like numerals being used for like and corresponding parts of the various drawings.

30 In certain embodiments in accordance with the invention (e.g., including embodiment(s) of the invention of the parent applications), ATM is used as a transport and switching mechanism in a hybrid STM/ATM network, while the signaling remains normal narrowband signaling. The narrowband signaling may be transported on permanent paths over ATM connections (e.g., permanent virtual connections (PVCs)), and the narrowband speech channels may be transported on ATM and switched

on a "per call basis" (e.g., on-demand) through an ATM switch (e.g., a switched virtual connection (SVC)).

The hybrid STM/ATM network has an access node which services narrowband terminals and which generates a signaling message in connection with call setup. A translator formats the first
5 signaling message into ATM cells so that the first signaling message can be routed through an ATM switch to a circuit switched (e.g., STM) node. The circuit switched node (e.g., PSTN/ISDN) sets up a physical connection for the call and generates a further signaling message for the call, the further signaling message pertaining to the physical connection. The ATM switch routes an ATM-cell-
10 formatted version of the further signaling message to another ATM switch over an ATM physical interface. Thus, the ATM switch switches both narrowband traffic and signaling for the call over the ATM physical interface. The ATM physical interface thus carries an ATM-cell-formatted version of the further signaling message amidst ATM traffic cells.

In view of the fact that the circuit switched node and the ATM switch employ different parameters (e.g., b-channel, etc., for the STM node and VP/VC for the ATM switch), in one
15 embodiment the STM node obtains global position numbers (GPN) for use in setting a path for the further signaling message through the ATM switch. In this regard, at the circuit switched node a translation is made from STM to GPN using an STM/GPN translation table; at the ATM node a translation is made from GPN to VP/VC/port using a GPN/ATM translation table.

The ATM-cell-formatted version of the further signaling message is transported over the ATM
20 physical link and ultimately reaches a destination access node which serves a destination terminal. A destination translator unpacks ATM cells carrying the ATM-cell-formatted version of the further signaling message to obtain the STM signaling information for use by the destination access node. The translators may be situated at the access node, for example. In illustrated embodiment(s), the ATM switches are situated at nodes distinct from the PSTN/ISDN nodes, but such need not be the case
25 in other embodiment(s). The signaling messages can be in accordance with the signaling system no. 7 (SS#7) convention, and the further signaling message can be one of an ISUP or a TUP message, for example.

Referring now to FIG. 3, an exemplary hybrid STM/ATM network 320 according to an
embodiment of the invention is illustrated. Narrowband terminal devices communicate with hybrid
30 STM/ATM network 320 through access nodes, such as access node 322_O and access node 322_D. For example, FIG. 3 shows terminals 324_O connected to access node 322_O, particularly ISDN terminal 324_{O,I} and PSTN terminal 324_{O,P}. Similarly, access node 322_D has access terminals 324_D connected

-11-

thereto, namely ISDN terminal 324_{D-I} and PSTN terminal 324_{D-P}. Of course, a differing (and most likely greater) number of terminals can be connected to each access node 322, but for simplicity only two such terminals are shown for exemplary purposes in FIG. 3. It should be noted that, as used herein, the term "access node" is not limited to a simple node used merely for connecting subscriber lines, for it may encompass other nodes such as a local exchange (LE) node, for example.

The hybrid STM/ATM network 320 of FIG. 3 comprises one or more STM nodes, also known as PSTN/ISDN nodes 330. While only two such PSTN/ISDN nodes 330₁ and 330₂ are shown in FIG. 3 for sake of illustration, it should be understood that the invention is not limited to only two such nodes. The structure and operation of conventional PSTN/ISDN nodes 330 are well known; such as those typified by utilization of Ericsson AXE switches, for example. Therefore, only selected pertinent portions of conventional PSTN/ISDN nodes 330 are described herein with reference to PSTN/ISDN node 330₁. For example, PSTN/ISDN node 330₁ has processor(s) 332 which execute, e.g., node application software including switch and resource control software 333. Such software is used to control STM circuit switch 335 as well as signaling terminals 337 which comprise PSTN/ISDN node 330₁. Other details of the structure and operation of a conventional PSTN/ISDN node are understood, for example, from United States Patent Application Serial No. 08/601,964 for "Telecommunications Switching Exchange", which is hereby incorporated by reference in its entirety herein.

The STM/ATM network 320 of certain embodiment(s) of the invention is considered a hybrid network in view of the fact that ATM nodes 340 are also included therein. As explained hereinafter, the ATM nodes 340 are used not only to route narrowband traffic between access nodes 322, but also for transport of signaling in ATM cells over an ATM physical interface. In the illustrated example, the ATM network aspect includes two exemplary ATM nodes, particularly ATM node 340₁ and ATM node 340₂, which are connected by ATM physical interface or link 341. Again, it should be understood that the ATM component can (and typically does) comprise a greater number of ATM nodes, with the nodes being connected by ATM physical links.

In hybrid network 320, a PSTN/ISDN node 330 and a ATM node 340 can be paired together in the manner illustrated in FIG. 3. With such a pair, the PSTN/ISDN node 330 and ATM node 340 are collectively referred to as hybrid node pair 330/340. The network 320 of certain embodiment(s) of the invention thus can comprise any number of hybrid node pairs 330/340. An ATM node such as ATM node 340 takes on differing configurations, but commonly has a main processor 342 or the like which executes application software including switch and resource control software as generally

-12-

depicted by 343 in FIG. 3. The heart of an ATM node is usually the ATM switch core or switch fabric, which for the illustrated embodiment is shown as ATM cell switch 345 in FIG. 3. Further information regarding an exemplary ATM switch is provided by United States Patent Application Serial No. 08/188,101, entitled "Asynchronous Transfer Mode Switch", filed November 9, 1998, which is hereby incorporated by reference in its entirety herein. ATM cell switch 345 has plural ingress ports and plural egress ports, with at least some of such ports having a device board attached thereto.

Each device board at ATM node 340 can have one or more different functions performed thereby or one or more different devices mounted thereon. For example, one of the device boards attached to a port of ATM cell switch 345 can, in one embodiment, have the main processor 342 mounted thereon. Other device boards may have other processors, known as "board processors". Some device boards serve as extension terminals (ETs) 346 which may be used to connect the ATM node to other nodes. For example, the ATM physical link 341 shown in FIG. 3 has a first end connected to an extension terminal ET 346₁ of ATM node 340₁, while a second end of ATM physical link 341 is connected to an unillustrated extension terminal ET of ATM node 340₂. The device boards connected to ATM cell switch 345 of ATM node 340 are not specifically illustrated in detail in FIG. 3, but the structure and operation of such device boards is understood with reference to (for example) the following United States Patent Applications, all of which are hereby incorporated by reference in their entirety herein: U.S. Patent Application Serial No. 08/893,507 for "Augmentation of ATM Cell With Buffering Data"; U.S. Patent Application Serial No. 08/893,677 for "Buffering of Point-to-Point and/or Point-to-Multipoint ATM Cells"; U.S. Patent Application Serial No. 08/893,479 for "VPNC Look-Up Function"; U.S. Patent Application Serial No. 09/188,097 for "Centralized Queuing For ATM Node", filed November 9, 1998.

As explained hereinafter, signaling (e.g., for call setup) is routed from an access node 322 through an ATM node 340 to an appropriate one of the PSTN/ISDN nodes 330. Such being the case, a circuit emulation or translator 350 is provided for each access node 322 which communicates with an ATM node 340. The translators 350 serve, e.g., to encapsulate signaling information from the access node 322 into ATM cells for signaling directed toward an ATM node 340, and conversely unpack ATM payloads received from an ATM node 340 to extract signaling information for use by the access node 322. In this particular illustrated embodiment, the translators 350 are preferably provided at or proximate to their associated access nodes 322. That is, translator 350_O may be situated at or included in access node 322_O; translator 350_D may be situated at or included in access node 322_D. A pair of

physical links, shown as links 351, are provided for connecting each access node 322 to a corresponding one of the ATM nodes 340.

ATM node 340 is connected to a PSTN/ISDN node 330 by a physical link 360. With reference to ATM node 340₁, for example, a pair of switch-to-switch links 360 is employed to connect
5 ATM cell switch 345 (through its circuit emulation board 370) to STM circuit switch 335 of PSTN/ISDN node 330, for the carrying of signaling messages. One of the links in pair 360 carries messages from ATM cell switch 345 (after translation at circuit emulation board 370) to STM circuit switch 335; the other link of the pair 360 carries messages in the reverse direction.

In the illustrated embodiment, a dedicated VPI, VCI internal to ATM cell switch 345 is used
10 for signaling. Thus, with reference to ATM node 340₁, for example, link 351₀ is connected to extension terminal (ET) 346₂, which in turn is connected to a first pair of dedicated ports of ATM cell switch 345. Signaling messages received at ATM node 340₁ which are destined to PSTN/ISDN node 330₁ are routed on the dedicated internal VPI/VCI to a port of ATM cell switch 345 which ultimately connects (via circuit emulator 370) to switch-to-switch links 360. However, since the signaling routed
15 through ATM cell switch 345 is encapsulated in ATM cells, a translation to the STM signaling must be performed prior to transmitting the signaling information on switch-to-switch links 360. For this reason, a device board connected to switch-to-switch links 360 has the circuit emulation (CE) or translator 370 mounted thereon.

The circuit emulation (CE) or translator 370 serves to unpack signaling information which is
20 destined to PSTN/ISDN node 330, but contained in ATM cells, so that the signaling information can be extracted from the ATM cells prior to application on switch-to-switch links 360. Conversely, signaling information received from PSTN/ISDN node 330₁ on switch-to-switch links 360 at translator 370 is encapsulated into ATM cells for routing through ATM node 340₁. From FIG. 3 it can also be seen that a plurality of interfaces 300a-300f are utilized in the hybrid STM/ATM network 320 of
25 certain embodiment(s) of the invention. These interfaces are described below, primarily with reference to the exemplary nodes (e.g., PSTN/ISDN node 330₁ and ATM node 340₁).

Interface 300a is a logical interface which exists between processor(s) 332 of PSTN/ISDN node 330₁ and main processor(s) 342 of ATM node 340₁. Interface 300a enables PSTN/ISDN node 330 to control the ATM node 340 connected thereto. That is, with the signaling carried by interface
30 300a, PSTN/ISDN node 330₁ can order physical connections which are to be set up in ATM node 340₁. Interface 300a can be a proprietary interface or an open interface (such as a General Switch Management Protocol (GSMP) interface [see Request For Comments (RFC) 1987]). Logical interface

300a can be carried on any physical interface, such as interface 360 described below. Alternatively, interface 300a can be carried by a separate link (e.g., between processors 332 and 342), or carried on top of IP/Ethernet links.

Interface 300b is the signaling between the PSTN/ISDN nodes 330 and the access node 322
5 connected thereto. Interface 300b is carried on one or more semipermanent connections through the STM circuit switch 335; through the interworking unit with circuit emulation 370 into ATM cell switch 345; and over permanent virtual connections to access node 322 (particularly to translator 350 in access node 322, where it is emulated back and terminated). As mentioned above, translator 350 is employed to encapsulate the narrowband signaling from an access node 322 in ATM cells for use by
10 an ATM node 340, and conversely for unpacking ATM cells with signaling information for use by an access node 322. Each STM channel on the user side may have a corresponding VPI/VCI on interface 300b.

Interface 300c is the non-broadband signaling that is carried through and between the nodes. Interface 300c thus carries the normal signaling system No. 7 (SS#7) interface (e.g., TUP or ISUP)
15 which is transparently carried in ATM-cell-formatted versions of signaling messages over ATM physical link 341. In PSTN/ISDN node 330, the signaling terminals 337 are used for common channel signaling. In at least one embodiment, signaling terminals 337 can be pooled devices situated at STM circuit switch 335. Alternatively, the signaling terminals 337 can be connected directly to the interfaces between the STM and ATM switches.

Interface 300d is the physical interface provided by switch-to-switch link 360. Interface 300d
20 can be used to carry speech for a call to and from an STM network, and also to carry the signaling of interface 300b and interface 300c as described herein. In addition, interface 300d can also be used to link-in special equipment that is to be connected to a normal circuit switch (e.g., conference equipment, answering machines, etc.). Interface 300d can be realized by any standard physical media,
25 such as E1, for example; it being understood that STM-1 or similar speeds may be suitable. The physical interface 300d can also carry the voice data for a conversation between any of the terminals shown in FIG. 3 and an unillustrated terminal connected to the circuit switched network, in which situation the hybrid node pair 330/340 acts as a gateway.

Interface 300e is the ATM physical link 341 to other ATM nodes. Any standard link for ATM
30 may be employed for interface 300e. A dedicated VP/VC is employed to transparently transfer the signaling system no. 7 (SS#7) signaling between PSTN/ISDN nodes 330 over interface 300e.

-15-

Interface 300f, shown in FIG. 3 as connecting each access node 322 with its terminals, is a typical user-network interface (e.g., ISDN, BA/BRA, PRA/PRI, two-wire PSTN, etc.).

For two traditional circuit switched PSTN/ISDN nodes to communicate with one another using protocols such as ISUP or TUP, it is preferable that ISUP entities in both PSTN/ISDN nodes have coordinated data tables. In this regard, each of the two PSTN/ISDN nodes has a table which translates a CIC value onto a same timeslot in a same physical interface connecting the two PSTN/ISDN nodes. Thus, a CIC value (together with a point code) represents a particular timeslot on a particular physical link. One specific CIC preferably points out the same time slot in the tables of both PSTN/ISDN nodes. In other words, the data tables of the two PSTN/ISDN nodes are preferably coordinated.

The need to coordinate the data tables of PSTN/ISDN node 330₁ and PSTN/ISDN node 330₂ for ISUP/TUP similarly exists in certain embodiment(s) of the invention. If two hybrid nodes 330₁/340₁ and 330₂/340₂ have a communication channel set up between them, by means of a semipermanent connection carrying SS#7 signaling for example, the translation tables 339 in both hybrid nodes are preferably coordinated from the standpoint of using CIC. This typically means that in both hybrid nodes 330₁/340₁ and 330₂/340₂ a certain CIC points at the same VP and VC (and possibly AAL2 pointer) identifying cells on a certain physical link (e.g., link 341) connecting the two hybrid nodes. Alternatively, the same objective may be accomplished by other suitable means such as a cross-connected-ATM switch positioned between the hybrid nodes that switches packets and gives the packets the VP and VC value understood by the other node.

Referring now to FIG. 3A, an exemplary structure of hybrid STM/ATM network 320, having omitted therefrom various items including the interfaces, is illustrated. FIG. 3A also provides an example of signal processing for a call originating at terminal 324_{O,P} for which the called party number (destination) is terminal 324_{D,P}. As shown by the arrow labeled E-1, at event E-1 a SETUP message is sent from terminal 324_{O,P} to access node 322_O. In the illustrated embodiment, the SETUP message is an IAM message for an ISUP network interface, and is for a 30B+D PRA and for VS.x carried on a 64 kb/s bit stream in a circuit switched timeslot.

At the translator 350_O associated with the access node 322_O, at event E-2 the signaling from terminal 324_{O,P} is converted from STM to ATM by packing the signaling information into ATM cell(s). In this regard, after the circuit emulation a table is employed to translate from a 64 kb/s speech channel from terminal 324_{O,P} to a corresponding ATM address (VP/VC). The signaling of the SETUP message, now encapsulated in ATM cell(s), is applied to link 351_O and transmitted to ATM cell switch

-16-

345 of ATM node 340₁ as indicated by event E-3. As further indicated by event E-4, the ATM cell(s) containing the SETUP message signaling is routed through the ATM cell switch 345 in accordance with a switch internal VP/VC dedicated for STM-originated signaling. Upon egress from ATM cell switch 345, the signaling information for the SETUP message is retrieved from the ATM cell(s) by translator 370 (event E-5), and it is reconverted at translator 370 from ATM to STM format, so that the SETUP message signaling information can be applied in STM format at event E-6 to switch-to-switch link 360. The SETUP message, now again in STM format, is routed through STM circuit switch 335 (as indicated by event E-7) to an appropriate one of the signaling terminals 337. Upon receipt of the SETUP message signaling information at the appropriate signaling terminal 337, the signaling information is forwarded to processor(s) 332 of PSTN/ISDN node 330, which engage in STM traffic handling (as indicated by event E-8).

In its traffic handling, the processor 332 of PSTN/ISDN node 330 realizes that the incoming side of the call and the outgoing side of the call have physical connections through an ATM node. In this regard, when the access points of the connection were defined (subscriber or network interface), a bearer type was associated with the connection and stored in application software. In the present scenario, when the SETUP message (e.g., an IAM message in the case of an ISUP network interface) was received at PSTN/ISDN node 330, the stored bearer type data was checked in order to determine what switch was on the incoming side to PSTN/ISDN node 330. Further, the bearer type data stored for the outgoing point (e.g., based on B-Subscriber number) is similarly checked, and if the stored data indicates that both incoming and outgoing sides have an ATM bearer, the PSTN/ISDN node 330 can conclude that ATM node 340 is to be operated (e.g., utilized). In addition, data received in the SETUP message (particularly the B-subscriber number) is analyzed to determine that the called party (destination) terminal 324_{D,P} can be reached by contacting PSTN/ISDN node 330₂. The PSTN/ISDN node 330₁ realizes that it has an SS#7 signaling interface 300c to PSTN/ISDN node 330₂, and therefore selects a free CIC (e.g., a CIC not used by any other call) for use toward PSTN/ISDN node 330₂. If, on the other hand, the stored bearer type data had indicated an STM bearer, both PSTN/ISDN node 330 and ATM node 340 have to be operated. Thus, PSTN/ISDN node 330 and ATM node 340 collectively function as a gateway between the STM and ATM worlds. Upon realizing that further signaling for the call will be routed through ATM nodes, in the embodiment(s) of the invention shown in FIG. 3 and FIG. 3A, the PSTN/ISDN node 330₁ makes reference to an STM/GPN translation table 339 maintained by processor(s) 332 (see event E-9). Two translations are performed using the STM/GPN translation table 339. As a first translation, the information (e.g., b-channel and access

-17-

information in the case of ISDN or CIC plus signaling system #7 point codes in the case of PSTN) contained in the SETUP message is translated to a global position number (GPN). As a second translation, the CIC and destination point code for a circuit leading to hybrid node pair 330/340 is translated to another global position number (GPN).

5 In connection with the foregoing, the global position number (GPN) is a common way to identify the connection points, and as such is understood by the pair of nodes (PSTN/ISDN node 330 and ATM node 340). In other words, the GPN is an address, or reference, or system internal pointer known by both PSTN/ISDN node 330 and ATM node 340, and used to translate between port/VP/VC and circuit switch address. Usage of GPN in the embodiment of FIG. 3 and FIG. 3A thereby obviates
10 the sending of real addresses between PSTN/ISDN node 330 and ATM node 340. Advantageously, GPN can be shorter, meaning that there is less data to send. For traditional PSTN, the GPN uniquely corresponds to the 64 kbit voice on a two-wire line, but for ISDN, the GPN corresponds to a b-channel (which may be used by several subscribers).

 Then, as event E-10, the PSTN/ISDN node 330 generates an ATM switch control message
15 intended to setup a physical connection in ATM node 340. This message of event E-10 contains the two global position numbers (GPNs) obtained from STM/GPN translation table 339 at event E-9, together with an order for the ATM node 340 to connect the two GPN addresses in ATM switch fabric 345. The PSTN/ISDN node 330 sends the switch control message generated at event E-10 to processor 342 of ATM node 340 over interface 300a, as shown by event E-11.

20 Upon reception of the switch control message sent as event E-11 to ATM node 340₁, as indicated by event E-12, main processor 342 consults GPN/ATM translation table 349 in order to translate the two global position numbers (GPNs) contained in the event E-10 switch control message into VP/VC/port information understood by ATM node 340₁. That is, the two global position numbers (GPNs) are used to obtain VP/VC/port information for ultimately reaching both the origination
25 terminal (324_{O,P}) and the destination terminal (324_{D,P}). Upon successful translation of GPN to ATM, and assuming sufficient resources, processor 342 of ATM node 340₁ sets up a path through ATM Switch 345 and reserves resources on the port (trunk or link 341) for the call from terminal 324_{O,P} to terminal 324_{D,P}. The path set up and resource reservation activities are accomplished using switch/reservation control 343 and are collectively illustrated as event E-13 in FIG. 3.

30 Since PSTN/ISDN node 330 preferably knows whether ATM node 340₁ was successful in performing a GPN/ATM translation, a successful translation message is sent over interface 300a as event E-14 from ATM node 340₁ to PSTN/ISDN node 330. If the GPN/ATM translation is not

-18-

successful at ATM node 340₁, or if there are no available resources at ATM node 340₁, a call rejection message is sent back to the originating terminal. After PSTN/ISDN node 330 receives the confirmatory message of event E-14 (that ATM switch 345 has been setup and link reservations made (in accordance with event E-13)), at event E-15 the PSTN/ISDN node 330₁ prepares and sends its
5 further signaling message (e.g., ISUP or TUP) toward the PSTN/ISDN node at the other end (e.g., PSTN/ISDN node 330₂). This further signaling message is shown as event E-15 in FIG. 3A. The signaling of event E-15 (e.g., an ISUP or TUP message) includes a message transfer part (MTP), and can be sent out on a timeslot (e.g., 64 kb/s) which carries the SS#7 signaling.

As the signaling of event E-15 arrives at ATM node 340₁, the ATM node 340₁ prepares its
10 ATM cell-formatted version of the signaling. In particular, the translator 370 puts the signaling information of the signaling of event E-15 into the payload of one or more ATM cells. For example, the translator 370 is configured to take the 64 kb/s signaling information bit stream and to pack it into ATM cells with a predefined VP, VC, and a physical port. As also indicated as event E-15, the ATM cell-formatted version of the further signaling message is routed through ATM cell switch 345 and
15 onto a link indicated by the VP/VC/port information obtained from the translation. In particular, in FIG. 3A the ATM cell-formatted version of the further signaling message is transported on ATM physical link 341, as shown by event E-16.

Upon reaching ATM node 340₂, the ATM cell-formatted version of the further signaling messages obtains a new internal VPI/VCI for the ATM cell switch 345 of ATM node 340₂, and is
20 routed (as indicated by event E-17) through ATM cell switch 345 of ATM node 340₂ to a circuit emulator (not explicitly shown) in ATM node 340₂, which is analogous to circuit emulator 370 in ATM node 340₁. The circuit emulator of ATM node 340₂ performs the conversion from ATM to STM format in like manner as circuit emulator 370 in ATM node 340₁, and then passes the signaling message to PSTN/ISDN node 330₂ as event E-18.

In PSTN/ISDN node 330₂, the ISUP message is received together with the CIC value (from the message transfer part (MTP)) and the B-subscriber number (which is included in the ISUP message). As indicated by event E-19, the second hybrid node 330₂/340₂ also performs an analysis of the B-subscriber number and concludes that the B-subscriber number is associated with terminal 324_{D-P},
25 which involves B channels. The PSTN/ISDN node 330₂ then selects a B-channel which can be used to reach terminal 324_{D-P}, or negotiates with the terminal 324_{D-P} as to which B-channel to use
30 (depending on the terminal type and protocol type ISDN or PSTN). The PSTN/ISDN node 330₂ also signals terminal 324_{D-P} to activate a ringing signal (as indicated by event E-20). When an answer is

received from terminal 324_{D-P} (or during or before receiving an answer), the PSTN/ISDN node 330₂ consults its STM/GPN translation table 339 (not explicitly shown) using a CIC value and a B-channel. The PSTN/ISDN node 330₂ then operates the ATM switch 345 (not explicitly shown) of ATM node 340₂ in the same manner as described for ATM node 340₁, as indicated by event E-21.

5 Operation of ATM switch 345 of ATM node 340₂ allows in-band data (e.g., voice data) carried in ATM packets to be passed through the ATM switch. Such operation is accomplished in like manner as described previously hereinabove (e.g., by consulting a table such as table 339, by sending an ATM switch control message, by consulting a table such as table 349, and by setting up of a path in the ATM switch). When an ATM switch is operated as described above, the resulting path through
10 both ATM switches (carrying in-band information) has to be set up in the same way at both ends. This implies that encapsulation of in-band information (which is controlled by circuit emulation (e.g., circuit emulation 370)) at the two end points of the path is preferably set up in the same way. To minimize delay, AAL2 is preferably utilized by circuit emulation 370 for the encapsulation, although other types of protocols may be alternatively used.

15 As noted hereinabove, a bearer type is associated with a connection and stored in the application software of the PSTN/ISDN node 330. It is presumed that the PSTN/ISDN node 330 already is able to handle traditional access points (subscriber or network interfaces) connected to STM circuit switches. In so doing, the PSTN/ISDN node 330 has logical representations of these existing access points in a static data structure of the PSTN/ISDN node 330. In accordance with certain
20 embodiment(s) of the invention, the PSTN/ISDN node 330 additionally handles access points connected to the ATM switch. In this regard, see (for example) interface 341 of FIG. 3C (hereinafter described). Thus, for certain embodiment(s) of the invention, the PSTN/ISDN node 330 has logical representations of these additional access points in its static data structure. Therefore, the bearer type data may be employed in the prior discussion as a way of distinguishing the logical representation of
25 the additional access points (e.g., ATM-related access points) in the static data structure from the logical representation of the traditional access points.

 It was also noted hereinabove that encapsulation of in-band information is preferably set up the same way at both ends. More specifically, a same type of cell filling is preferably employed by two circuit emulation devices that are connected together. For example, if on a link connecting two
30 circuit emulation devices an ATM cell is packed with only one voice sample by a first of the circuit emulation devices, the second of the circuit emulation devices preferably packs ATM cells in a similar manner. Alternatively, another emulation and/or bridging mechanism or scheme may be employed.

-20-

In the above regard, filling only part of an ATM cell with information is a technique for reducing delays, although it may increase overhead. Another way of reducing delay is employment of the AAL2 protocol. As understood by those skilled in the art, AAL2 is a protocol layer on top of ATM, and it allows transport of mini-cells within ATM cells. Usage of the smaller AAL2 cells helps address
5 bandwidth and delay problems in the air interface. Certain embodiment(s) of the invention may be utilized with AAL2 switching as an alternative to ATM switching. If one implements AAL2 in certain embodiment(s) of the invention, the switch 345 operates as an AAL2 switch and GPN/ATM translation table 349 in ATM node 340 preferably also includes an AAL2 pointer. Whenever the ingress and egress point is referenced, it can alternately include an AAL2 pointer. Thus, as used
10 herein and in the appended claims, ATM encompasses ATM-related protocols on top of ATM, such as AAL1, AAL2, AAL5, etc. It should also be understood that the term "broadband", as used herein and in the appended claims, embraces and encompasses packet-switched technologies in general (e.g., IP, VoIP, Frame-relay, ATM, etc.).

Referring now to FIG. 3B, an exemplary hybrid STM/ATM network 320' according to another
15 embodiment of the invention is illustrated. The embodiment of FIG. 3B primarily differs from the embodiment of FIG. 3 in that the embodiment of FIG. 3B does not employ global position numbers (GPNs). Rather, the embodiment of FIG. 3B uses an ATM/STM translation table 339' in processor 332 of PSTN/ISDN node 330₁ instead of an GPN/ATM translation table. In the embodiment of FIG. 3B, the translation tables in the circuit emulation 350₀ translate the SETUP message from a 64 kb/s
20 speech channel to an ATM address (VP and VC) in a manner similar to that of event E-2 in the embodiment(s) of FIG. 3 and FIG. 3A. After routing of the translated SETUP message through ATM switch 345₁, the circuit emulation 370 translates the SETUP message to the STM format as occurred at event E-5 of the embodiment(s) of FIG. 3 and FIG. 3A.

The embodiment of FIG. 3B also differs from that of the embodiment(s) of FIG. 3 and FIG.
25 3A in that processor 332 of PSTN/ISDN node 330 terminates the narrowband signaling by translating a narrowband reference point (e.g., b-channel if an ISDN connection) to a corresponding ATM address for use by ATM node 340. Thus, for the FIG. 3B embodiment, the switch control message of event E-11 sends the ATM VP/VC/port information understood by ATM node 340₁. Thus, the translation of event E-12 of the FIG. 3/FIG. 3A embodiment is unnecessary in the FIG. 3B embodiment. Rather,
30 upon receiving the ATM VP/VC/port information in the switch control message of event E-11, the embodiment of FIG. 3B proceeds to the path set up and resource reservation operations denoted as event E-13.

The principles as illustrated in the embodiments hereof are also applicable to the carrying of other types of signaling messages in ATM cells. Included among such other types of signaling messages are those destined for the originating terminal (e.g., a call completion signaling message), in which case some of the events described herein are performed essentially in reverse order.

5 Referring now to FIG. 3C, an exemplary illustration of how hybrid node pairs 330/340 of the invention may be arranged in an exemplary hybrid STM/ATM network 320" is presented. Network 320" has three node pairs 330/340, including a transit exchange hybrid node pair 330/340_{TX} between two local exchange hybrid node pairs 330/340₁ and 330/340₂. FIG. 3C shows provision of a "#7 signaling system" 393, which is a logical system carried in the ATM network on an ATM AAL layer as described above. As an alternative embodiment, the "#7 signaling system" 393 may be provided with
10 its own physical network.

Referring now to FIG. 3D, a diagrammatic view of an exemplary protocol usable between two elements of a network in accordance with embodiment(s) of the invention that include hybrid node pairs is illustrated. The ATM node 340 with its ATM switch 345 terminates the ATM and AAL1
15 (circuit emulation part) layers; the PSTN/ISDN node 330 terminates the MTP and ISUP layers.

Referring now to FIGS. 3E, 3F, and 3G, diagrammatic views of alternate exemplary protocols between two elements, a first of the network elements having a hybrid node pair in accordance with embodiment(s) of the invention, and a second of the network elements being an access node with an additional ATM interface with circuit emulation is illustrated. In the first network element, the ATM
20 switch 345 terminates the ATM and AAL1 (circuit emulation part) layers, while the layers above are terminated by the PSTN/ISDN node 330. In the second network element, the ATM interface and circuit emulation addition to the access node terminates the ATM and AAL1 layers, while the layers above are terminated by the connected terminal and the access node part. The exemplary protocols of FIGS. 3E, 3F, and 3G can be used, for example, on the interface 300b.

25 Referring now to FIG. 3H, an exemplary gradual upgrade of a network from a traditional narrowband STM-transported-and-switched environment into the environment (e.g., hybrid STM/ATM network 320) of certain embodiment(s) of the invention is illustrated. In FIG. 3H, the circuit emulation equipment (translator) 395 separates the hybrid environment from the pure STM environment. If node B (PSTN/ISDN node 330_{N+1}) is upgraded with ATM switching and (signaling and traffic) transport according to certain embodiment(s) of the invention, the node C (PSTN/ISDN
30 node 330_{N+2}) is not disturbed if the circuit emulation equipment (translator) 395 is moved in between nodes B and C in the manner illustrated by the dotted-dashed line 396 as shown in FIG. 3H.

-22-

Referring now to FIG. 3I, certain embodiment(s) of the invention permit the possibility of one logical node to include many switches, with switching logic within the node coordinating the setting up of paths through the switches. This logic also inserts interworking functions (IWFs) between switches (if needed), and makes it possible to use resources independent on which switch they are allocated to. For example, the multi-switch node 397 of certain embodiment(s) of the invention includes the PSTN/ISDN node 330 with its STM switch 335, connected by interface 300d to ATM node 340₇₋₁. Specifically, connection is made through IWF 344₇₋₁ to ATM switch 345₇₋₁ of ATM node 340₇₋₁. The ATM switch 345₇₋₁ of ATM node 340₇₋₁ is connected by interface 300e to an ATM network, as well as to ATM node 340₇₋₂ and ATM node 340₇₋₃ included in the multi-switch node 397. The ATM node 340₇₋₂ has a switch 345₇₋₂ and an IWF 344₇₋₂, through which connection can be made with access node 322₇₋₁. The ATM node 340₇₋₃ has an ATM AAL2 switch 345₇₋₃, which connects to ATM nodes 340₇₋₁ and 340₇₋₂ through IWF 344₇₋₃ of ATM node 340₇₋₃. Access nodes 322₇₋₂ and 322₇₋₃ are connected to ATM AAL2 switch 345₇₋₃ of ATM node 340₇₋₃.

Certain embodiment(s) of the invention advantageously reuse PSTN and ISDN software in the PSTN/ISDN nodes 330 in a fairly simple way. That is, already-developed narrowband application software residing in the PSTN/ISDN nodes 330 can be utilized, while on-demand ATM connections are used as traffic bearers. The invention thus allows a PSTN/ISDN node such as PSTN/ISDN node 330 to control the call, which facilitates use of well-proven software for various services and functions (e.g., subscriber services, intelligent network (IN) services, Centrex, Charging Customer Care systems, etc.).

ATM is thus used as a transport and switching mechanism in certain embodiment(s) of the invention, while the signaling remains normal narrowband signaling. The narrowband signaling is transported on permanent paths over ATM connections, and the narrowband speech channels are transported on ATM, and switched on a "per call basis" (e.g., on-demand) through an ATM switch. The narrowband application software executed by processor(s) 332 of PSTN/ISDN nodes 330 thus acts as if operating on its STM circuit switched transport, when in fact it is actually operating on an ATM cell switch. It should be understood that the ATM switch may reside in a separate ATM node or may be integrated in the same node as the STM switch. On a "per call basis", the switching logic in the PSTN/ISDN nodes 330 requests the switching mechanism in the ATM nodes 340 to be set up and disconnected through an ATM cell switch.

It should be understood that variations of the foregoing are within the scope of the embodiments of the invention. For example, the circuit emulation 370 is shown (e.g., in FIG. 3) as

being provided on a device board of ATM node 340. Alternatively, circuit emulation 370 may be located elsewhere, such as (for example) on link 360 between PSTN/ISDN node 330 and ATM node 340, or even included in PSTN/ISDN node 330 (e.g., at either end of interface 300d). While various processors, such as processors 332 and 342, have been illustrated as single processors, it should be
5 understood that the functionality of such processors may be situated or distributed in different ways (e.g., distributed over several processors to achieve, e.g., scalability in respect to processing capacity and reliability), for example.

In the foregoing examples, the SETUP message (received at the STM node in STM format) is routed through STM circuit switch 335 as indicated by the event E-8 to signaling terminals 337. It
10 should be understood, however, that depending upon implementation in an PSTN/ISDN node, signaling may take another way to reach a signaling terminal (e.g., other than through a switch). The invention also describes a system with one STM switch and one ATM switch associated with one another. This particular configuration is advantageous in that resources which take care of certain kinds of signals (e.g., in-band signals) may be situated in the STM switch and be used also for the
15 ATM transported calls. This is also a way of reusing the installed base, if such exists. Also, certain embodiment(s) of the invention can perform switching on various levels, such as the AAL2 level and with mini-cells, which tends to reduce any delay/echo problems.

The invention thus pertains to the telecommunications world and an attempt to introduce ATM to a telecommunications network. The invention addresses the situation in which a circuit switched
20 telephony network pre-exists, and it is to be augmented or partially replaced by parts that employ ATM for transport and switching. Certain embodiment(s) of the invention need not employ broadband signaling, but rather narrowband signaling with the bearer part of the call following the signaling to the same extent as in a traditional narrowband circuit switched network.

As described herein, ATM may be used as a transport and switching mechanism in a hybrid
25 STM/ATM network, while the signaling remains normal narrowband signaling. The narrowband signaling may be transported on permanent paths over ATM connections, and the narrowband speech channels may be transported on ATM and switched on a "per call basis" (e.g., on-demand) through an ATM switch. The hybrid STM/ATM network may include an access node that services narrowband terminals and which generates a signaling message in connection with call setup. A translator formats
30 the first signaling message into ATM cells so that the first signaling message may be routed through an ATM switch to a circuit switched (e.g., STM) node. The circuit switched node (e.g., PSTN/ISDN) sets up a physical connection for the call and generates a further signaling message for the call, the

further signaling message pertaining to the physical connection. The ATM switch routes an ATM cell-formatted version of the further signaling message to another ATM switch over an ATM physical interface. Thus, the ATM switch switches both narrowband traffic and signaling for the call over the ATM physical interface.

5 Referring now to FIG. 4, another exemplary scheme for utilizing a broadband network in conjunction with nodes having partially separated functions in accordance with the present invention is illustrated generally at 400. The nodes 405A,405B are connected to the nodes 410A,410B. The nodes 405A,405B each include both call control functions and connection control functions. In effect, each of the nodes 405A,405B (e.g., which may correspond to, for example, PSTN/ISDN nodes 330 of the
10 embodiment(s) of FIGS. 3 et seq.) include both switching intelligence (e.g., which may correspond to, for example, one or more of processor(s) 332, switch and resource control software 333, signaling terminals 337, and STM/GPN translation table 339 of the embodiment(s) of FIGS. 3 et seq.) and switching fabric (e.g., which may correspond to, for example, an STM circuit switch 335 of the embodiment(s) of FIGS. 3 et seq.). While the nodes 410A,410B include connection control functions,
15 they rely on the call control functions of the nodes 405A,405B to which they are respectively connected. In effect, each of the nodes 410A,410B (e.g., which may correspond to, for example, ATM nodes 340 of the embodiment(s) of FIGS. 3 et seq.) include switching fabric (e.g., which may correspond to, for example, an ATM cell switch 345 of the embodiment(s) of FIGS. 3 et seq.). The nodes 410A,410B, which are also connected to an ATM network 215, effect required emulation and
20 cell packing for interworking a narrowband network (not shown) with the ATM network 215.

Generally, and in certain embodiment(s), call control involves features, functions, responsibilities, etc. pertaining to one or more of the following: routing a call; signaling between narrowband nodes; providing subscriber services; implementing charging; determining the connection and/or activation of tone senders, answering machines (e.g., voice mail), echo cancelers, and other
25 types of telephony resources and/or equipment; ascertaining the desirability and/or necessity of utilizing an IN service; etc. Connection control, on the other hand, involves features, functions, responsibilities, etc. pertaining to setting up/establishing a connection between two (or among/across multiple) physical points within a switch and/or over a network responsive to call control, for example. The connection control, to effectuate such a connection, may rely on some type of signaling of the
30 bearer network (e.g., UNI, PNNI, B-ISUP, etc.)

In accordance with certain embodiment(s) of the present invention, the nodes 405A,405B may be advantageously realized using, at least partly, a modified version of an existing/legacy

-25-

telecommunications switch. Using an existing telecommunications switch advantageously obviates any need to create code "from scratch" for the myriad of advanced calling features that are already supported by the existing telecommunications switch. Furthermore, in accordance with certain principles of the present invention, using an existing telecommunications switch enables a gradual migration to a broadband transport mechanism such as ATM. A call/connection control node 405A,405B and a respective connection control node 410A,410B pair together form a hybrid switch 420A/420B.

Referring now to FIG. 5, yet another exemplary scheme for utilizing a broadband network in conjunction with nodes having partially separated functions in accordance with the present invention is illustrated generally at 500. The two hybrid switches 420A,420B are illustrated as being connected to the ATM network 215 by ATM links 505 (e.g., which may correspond to, for example, one or more of interface 300c, interface 300e, and ATM physical link 341 of the embodiment(s) of FIGS. 3 et seq.), e.g., via a connection control node 410. Each of the call/connection control node 405A and the connection control node 410A are connected to a Time Division Multiplexed (TDM) network 515 by TDM links 510 (e.g., which may correspond to, for example, interface 300d of embodiment(s) of FIGS. 3 et seq. [including alternative embodiment(s) of FIGS. 3 et seq. as described hereinabove with reference to the interface 300d of FIG. 3]; as well as interface 300b/link 351, interfaces 300b,300c, and/or interface 300d/switch-to-switch link 360). The TDM network 515 may correspond to any of many so-called narrowband networks such as PSTN, PLMN, ISDN, etc. As indicated within the hybrid switch 420A, the call/connection control node 405A is connected to the connection control node 410A via a TDM link 510 (e.g., which may correspond to, for example, interface 300b, interface 300c, interface 300d, switch-to-switch link 360, etc. of FIGS. 3 et seq.) and an ethernet link 520 (e.g., which may correspond to, for example, interface 300a, interface 300b, interface 300c, switch-to-switch link 360, etc. of FIGS. 3 et seq.).

The hybrid switch 420 advantageously enables an existing switch in conjunction with an associated switch to facilitate the transport of call connections at least partly across a broadband network, such as the ATM network 215. As illustrated in the scheme 500, the existing switch may be realized using, for example, an AXE switch (available from Ericsson Inc.), and the associated switch may be realized using, for example, an AXD 301 switch (also available from Ericsson Inc.). Thus, the hybrid switches 420A,420B may be realized using, for example, an Ericsson Hybrid Switch (also available from Ericsson Inc.).

-26-

Referring now to FIG. 6, another exemplary hybrid switch with multiple ports for switching a connection in accordance with the present invention is illustrated generally at 420. The hybrid switch 420 includes a call/connection control node 405 and a connection control node 410 that are connected by linkage 605 (e.g., which may correspond to, for example, one or more of interface 300a, interface 300b, interface 300c, interface 300d, and switch-to-switch link 360 of the embodiment(s) of FIGS. 3 et seq.). It should be noted that the thick line representing the linkage 605 indicates that the linkage 605 may be composed of more than one link. Information exchange across linkage 605 permits the call/connection control node 405 to switch narrowband calls across the switching fabric of the connection control node 410. Such information exchange enables 64kbit/sec, narrowband calls originating and terminating in narrowband networks (e.g., one or more TDM networks 515) to be trunked over broadband networks (e.g., one or more ATM networks 215) between hybrid switches 420. It should be noted that TDM as used herein, including the claims, encompasses and embraces time-division multiplexed protocols in general, and it is not limited to any particular TDM protocol.

The call/connection control node 405 includes input/outputs (I/Os) for two TDM links 510. Each TDM link 510 terminates at exchange termination (ET) equipment 610. Each ET equipment 610 is connected to a group switch (GS) 615 (e.g., which may correspond to, for example, the STM circuit switch 335 of the embodiment(s) of FIGS. 3 et seq.). Each ET equipment 610 receives from the GS 615 data samples taken from multiple calls and multiplexes this data into a stream of data sent out over a TDM link 510 that connects the hybrid switch 420 to another node. The ET equipment 610 also receives data from other nodes over the TDM link 510 and de-multiplexes this data into samples from separate calls to be transferred to the GS 615. The GS 615 is also connected to one or more signaling terminals (STs) 620 (e.g., which may correspond to, for example, the signaling terminals 337 of the embodiment(s) of FIGS. 3 et seq.). The linkage 605 may include a TDM link 510 (not explicitly shown in FIG. 6) that connects an ET equipment 610 of the call/connection control node 405 with a circuit emulation-ET (CE-ET) equipment 625 (e.g., which may correspond to, for example, the circuit emulation/translator 370 of the embodiment(s) of FIGS. 3 et seq.) of the connection control node 410.

The connection control node 410 includes I/Os for two TDM links 510. Each TDM link 510 terminates at CE-ET equipment 625 (e.g., which may correspond to, for example, the extension terminal ET 346₂ (optionally in conjunction with the circuit emulation/translator 350) of the embodiment(s) of FIGS. 3 et seq.). Each CE-ET equipment 625 is connected to an ATM switch 630 (e.g., which may correspond to, for example, the ATM switch 345 of the embodiment(s) of FIGS. 3 et seq.). The CE-ET equipment 625 terminates a TDM link 510 for the ATM switching fabric of the connection control node 410 by using circuit emulation. The circuit emulation, e.g., hardware on a CE-ET equipment 625 maps time slots from an E1 line into, for example, single streams of ATM adaptation layer 1 (AAL1) cells. The CE-ET equipment 625 maps successive octets from a single time slot to a single stream of AAL1 cells. The ATM switch 630 is also connected to one or more ATM-ET equipments 635 (e.g., which may correspond to, for example, the extension terminal ET 346₁ of the embodiment(s) of FIGS. 3 et seq.). Each ATM-ET equipment 635 terminates an ATM link 505 to the ATM switching fabric of the connection control node 410.

The various ports/interfaces of the call/connection control node 405 and the connection control node 410 enable the establishment of various connection paths in the hybrid switch 420. Connection paths may be established across the following exemplary points as enumerated in Table 1:

(1) point A - (I, J) - G
(2) point A - (I, J) - H
(3) point D - (J, I) - B
(4) point E - (J, I) - B
(5) point C - (I, J) - G
(6) point C - (I, J) - H
(7) point D - (J, I) - F

(8) point D - G
(9) point D - H
(10) point E - (J, I) - F
(11) point E - G
(12) point E - H

Table 1 -- Connection Paths Establishable for FIG. 6.

Taking connection path "(6) point C - (I, J) - H", for example, a connection may be established from point "C" at the TDM link 510, through two ET equipments 610 and the GS 615, to point "I". The connection continues from point "I" across the linkage 605 to point "J". The connection continues further from point "J" through a CE-ET equipment 625, the ATM switch 630, and the ATM-ET equipment 635 to point "H" at the ATM link 505.

Referring now to FIG. 7, a simplified block diagram of an exemplary hybrid switch in accordance with the present invention is illustrated generally at 700. The hybrid switch at 700 includes a call/connection control node 405, which is shown connected to a TDM network 515 via a TDM link 510, and a connection control node 410, which is shown connected to a TDM network 515 via a TDM link 510 and an ATM network 215 via an ATM link 505. The call/connection control node 405 is connected to the connection control node 410 via the linkage 605, which may include one or more links. The connection control node 410 includes connection control logic 705 and the ATM switch 630. The connection control logic 705 may be composed of, for example, hardware, software, firmware, some combination thereof, etc.

The ATM switch 630 is connected via link 710 to the GS 615 of the call/connection control node 405. The link 710 may be utilized to transfer data information between the ATM switch 630 and the GS 615. The call/connection control node 405 also includes connection control logic 715 to enable the call/connection control node 405 to switch calls (e.g., to or through the TDM network 515 directly connected thereto via the TDM link 510) without the aid of the connection control node 410. The connection control logic 715 may also be composed of, for example, hardware, software, firmware, some combination thereof, etc. The call/connection control node 405 further includes call control

logic 720, which provides call control functions for the connection control node 410 as well as the call/connection control node 405. The call control logic 720 may also be composed of, for example, hardware, software, firmware, some combination thereof, etc.

The call control logic 720 may provide call control functions to the connection control node 5 410 by exchanging signaling information over a link 725. (It should be noted that either or both of the links 710 and 725 may be composed of more than one link.) For example, for a call incoming to the connection control node 410 over the TDM link 510 from the TDM network 515, signaling information may be forwarded to the call control logic 720 from the connection control logic 705 over the link 725. The switching intelligence of the call control logic 720 executes applicable call control 10 functions and ascertains relevant call control information (e.g., as explained further hereinabove with reference to FIGS. 3 et seq.). This signaling information is sent from the call control logic 720 over the link 725 to the connection control logic 705, which may thereafter switch the call data information of the incoming call to/through the appropriate network (e.g., the ATM network 215). The call control functions of existing (e.g., STM) switches can therefore be advantageously utilized by newer and 15 faster (e.g., ATM) switches to thereby avoid needing to completely reprogram call control functionality for the newer switches.

It should be emphasized that the call/connection control node 405 is capable of connecting directly to the TDM network 515 over the TDM link 510 via the GS 615. Consequently, a hybrid switch architecture in accordance with the present invention, by combining a call/connection control 20 node 405 with a connection control node 410, enables this logical node to communicate (i) with an existing TDM network 515 (e.g., a PSTN network) using the GS 615 (e.g., an STM switch) and (ii) with a broadband network (e.g., the ATM network 215) over a broadband link (e.g., the ATM link 505) using a broadband switch (e.g., the ATM switch 630). Providing such dual connectivity advantageously enables a network to gradually migrate from a first network protocol (e.g., a 25 narrowband network protocol) to a second network protocol (e.g., a broadband network protocol) while utilizing both existing call control logic (e.g., software, etc.) and existing connections to and within the first network (e.g., a narrowband network).

Referring now to FIG. 8, exemplary communications and connections between nodes in another simplified block diagram of an exemplary hybrid switch in accordance with the present 30 invention are illustrated generally at 800. In the exemplary hybrid switch 420, the call/connection control node 405 is connected to the connection control node 410 via the linkage 605 at points I and J. The linkage 605 may be composed of multiple links. In this exemplary embodiment 800, a signaling

information link 805 (e.g., which may correspond to, for example, interface 300a, interface 300b, interface 300c, switch-to-switch link 360, etc. of FIGS. 3 et seq.) and a data information link 810 (e.g., which may correspond to, for example, interface 300b, interface 300c, interface 300d, switch-to-switch link 360, etc. of FIGS. 3 et seq.) are illustrated as connecting the call/connection control node 405 to the connection control node 410. The signaling information link 805 may carry signaling communications between the call/connection control node 405 and the connection control node 410, and the data information link 810 may carry data communications between the call/connection control node 405 and the connection control node 410. Such data communications may include voice or data calls, for example.

10 In an exemplary embodiment, the signaling information link 805 is realized using two ethernet links. One ethernet link may be used for transmitting signaling information from the call/connection control node 405 to the connection control node 410 while the other ethernet link may be used for transmitting signaling information from the connection control node 410 to the call/connection control node 405. It should be understood that ethernet links are typically duplex in nature and that any
15 ethernet links employed in any particular embodiment(s) in accordance with the present invention may also be duplex. The data information link 810 may be realized using a TDM link. For example, the data information link 810 may be composed of one or more E1 lines. Communications necessary and/or beneficial to establishing the various connections described hereinabove with reference to FIGS. 6 and 7, for example, may be effectuated across the signaling information link 805 and the data
20 information link 810. Advantageously, because separate links are employed between the nodes 405 and 410, signaling information and data information may be transferred therebetween across links 805 and 810, respectively, without needing to specify whether the transmitted information pertains to signaling or to data.

As illustrated generally at 800, the call/connection control node 405 is connected to two TDM
25 networks 515, and the connection control node 410 is connected to two TDM networks 515 as well as two ATM networks 215. It should be noted that the number of networks to which the nodes 405 and 410 are connected is exemplary only. The flexibility of the hybrid node 420 advantageously enables calls to be incoming at either of the nodes 405 and 410 and to be forwarded via a connection of either of the nodes 405 and 410. In other words, a narrowband call incoming to the connection control node
30 410 (at point D) or a broadband call (e.g., a narrowband call being carried by a broadband transport mechanism, etc.) incoming to the connection control node 410 (at point E) may be forwarded from the connection control node 410 (as a narrowband or broadband call at point G or point H, respectively) or

from the call/connection control node 405 as a narrowband call (e.g., at point F). Furthermore, a narrowband call incoming to the call/connection control node 405 (at point C) may be forwarded from the call/connection control node 405 as a narrowband call (at point F) or from the connection control node 410 (e.g., as a narrowband or broadband call at point G or point H, respectively). It should be noted that other combinations of ingress and egress (e.g., other connection paths) are possible.

By way of a first example but not limitation, assume that a call (or, more generally, a communication) is incoming to the connection control node 410 from a TDM network 515 at point D. The signaling information related to the call (e.g., an ISUP Initial Address Message (IAM)) is encapsulated into ATM cells (e.g., at the CE-ET equipment 625 at point D) and passed to the ATM switch 630. Advantageously, the signaling information may therefore be piped through the connection control node 410 and over the (e.g., ethernet-based) signaling information link 805 without reformatting after being de-packaged from ATM cells (e.g., at the CE-ET equipment 625 at point J). The signaling information therefore need not be modified inasmuch as it may be transported through "transparent" pipes across the ATM switching fabric of the connection control node 410 (e.g., using a permanent virtual path connection (PVPC) pipe or similar, etc.).

When the GS 615 and associated call control logic (not explicitly shown in FIG. 8) receive the signaling information of the incoming call, the signaling information is analyzed (e.g., by an ST 620 at point A or point B). The traffic call handling is performed by, for example, performing a B-number analysis, accessing an interactive voice response system, contacting an Intelligence Network (IN) node 815 (e.g., for "(800)" call routing, etc.), consulting a database of bearer capabilities for destination and/or transit nodes, etc. If, in contradistinction to the example described hereinabove with reference to FIG. 3A, the call/connection control node 405 determines that the call should not or can not be routed through a broadband ATM transport mechanism, then the call/connection control node 405 instructs the connection control node 410 (e.g., over the signaling information link 805) to route the data information of the call to (and through) the call/connection control node 405.

The data information of the call is routed through the connection control node 410 from point D to point J (e.g., by piping the data information via a semi-permanent connection through the switching fabric of the ATM switch 630). It should be noted that the data information may be propagated through the connection control node 410 without reformatting by, for example, encapsulating the data information in ATM cells. Thereafter, the data information is forwarded from point J to point I over the data information link 810 in, for example, a TDM format. The ET equipment 610 receives the data information of the call, and the GS 615 switches it toward the

-32-

appropriate TDM network 515 (e.g., through an ET equipment 610 to a point C or a point F) in accordance with the earlier traffic call analysis.

By way of a second example but not limitation, assume that a call is incoming to the call/connection control node 405 from a TDM network 515 at point C. The call/connection control node 405 performs a traffic call analysis based on signaling information of the call. If the analysis indicates that the call can (and optionally should) be sent over a broadband transport mechanism, the call/connection control node 405 can direct the incoming call through the connection control node 410 and then to an ATM network 215, instead of directing the call to a TDM node in a TDM network 515 (e.g., through the ET equipment 610 at the point F). In this regard, the GS 615 may switch the call signaling information to the ATM switch 630 via the signaling information link 805 and the call data information to the ATM switch 630 via the data information link 810 (and appropriate ET equipment 610 and CE-ET equipment 625 at point I and point J, respectively). The ATM switch 630 may thereafter send the signaling information of the call over permanent connections set up in the broadband ATM network 215 and the data information of the call over, e.g., call-specific connections in the broadband ATM network 215 (via an ATM-ET equipment 635 at point E or point H).

Referring now to FIG. 9, an exemplary method in flowchart form for communicating between nodes in a hybrid switch in accordance with the present invention is illustrated generally at 900. In the exemplary method of flowchart 900, an incoming call is initially received at a first node (step 905). The first node sends signaling information related to the incoming call to a second node via a first link (step 910). The second node, which may provide call control for the first node, processes the signaling information (step 915) to determine how and to where the incoming call is to be routed. The second node sends instructions to the first node (e.g., via the first link) (step 920) directing the first node on how/where to route the incoming call. Assuming that the second node determined that the incoming call should be routed as an outgoing call from the second node (at step 915) and that the instructions sent to the first node (at step 920) so indicated, data information related to the incoming call is sent from the first node to the second node via a second link (step 925).

Alternatively, an incoming call can be received at a node capable of processing the corresponding signaling information. Accordingly, both signaling information and data information corresponding to the incoming call may be sent to an associated node via first and second links, respectively, if the node receiving the incoming call determines that it is appropriate to do so (e.g., as described hereinabove in the second example referencing FIG. 8). The call control functions of existing (e.g., STM) switches can therefore be advantageously utilized by newer and faster (e.g.,

ATM) switches to thereby avoid needing to completely reprogram the call control functionality for the newer switches. Furthermore, hybrid switches including both narrowband and broadband switches enable greater versatility for switching communications between broadband and narrowband transport mechanisms. For example, a hybrid switch may receive a communication that is being transported in a narrowband format and forward the communication in a broadband format, or vice versa. This ability is particularly advantageous for enabling a gradual migration in a network from being primarily or entirely narrowband to being primarily or entirely broadband.

Referring now to FIGS. 10A-10E, a first set of exemplary traffic scenarios for a hybrid switch in accordance with the present invention is illustrated. In FIG. 10A, a hybrid switch 420 is illustrated as being connected to two local exchange/transit exchange (LE/TE) nodes via TDM links, which may operate using an "N-ISUP" protocol, for example. The hybrid switch 420 is illustrated as receiving and forwarding a communication 1000. It should be understood that the detailed traffic scenarios illustrated in FIGS. 10B-10E are also applicable to other instances besides when a hybrid switch 420 is directly connected to a local exchange/transit exchange node on both sides of a communication 1000. For instance, the traffic scenarios of FIGS. 10B-10E are applicable whenever both the incoming and the outgoing side of a communication are transported on a narrowband transport mechanism such as TDM.

In FIG. 10B, the communication 1010 (which represents a particular traffic scenario and/or portion of the communication 1000) may be terminated and switched entirely within the narrowband portion of the hybrid switch 420. In FIG. 10C, the incoming side of a communication 1020 is terminated in the narrowband portion of the hybrid switch 420 while the outgoing side is terminated at the broadband portion (e.g., using a circuit emulation (CE) board). The switching occurs partly within the narrowband portion and partly within the broadband portion of the hybrid switch. In FIG. 10D, both of the incoming and the outgoing sides of a communication 1030 are terminated in the broadband portion of the hybrid switch 420. In this scenario, a, e.g., circuit emulation board is utilized on both the ingress and the egress sides of the, e.g., TDM connection. The switching may be effectuated entirely within the switching fabric of the broadband portion. In FIG. 10E, the incoming side of a communication 1040 is terminated by the broadband portion of the hybrid switch 420 whereas the outgoing side is terminated at the narrowband portion. Switching of the communication 1040 is therefore effectuated partly within the broadband portion (e.g., using an ATM switch 630) and partly within the narrowband portion (e.g., using a GS 615) of the hybrid switch 420.

Referring now to FIGS. 10F-10K, a second set of exemplary traffic scenarios for a hybrid switch in accordance with the present invention is illustrated. In FIG. 10F, multiple hybrid switches 420 are illustrated as being connected to each other and ultimately to two local exchange/transit exchange nodes. The hybrid switches 420 are illustrated as receiving and forwarding a communication 1000. A connection between two hybrid switches 420 may be realized using an ATM link, which may carry an "N-ISUP" protocol thereon, for example. A connection between a hybrid switch 420 and a local exchange/transit exchange may be realized using a TDM link, which may operate using an "N-ISUP" protocol, for example.

It should be understood that the detailed traffic scenarios illustrated in FIGS. 10G-10J are also applicable to other instances besides when a hybrid switch 420 is directly connected to a local exchange/transit exchange node on a single side of a communication 1000. For instance, the traffic scenarios of FIGS. 10G-10J are applicable whenever one side of a communication is transported on a narrowband transport mechanism such as TDM and the other side of the communication is transported on a broadband transport mechanism such as ATM. Likewise, it should be understood that the detailed traffic scenario illustrated in FIG. 10K is also applicable to other instances besides when a hybrid switch 420 is directly connected to hybrid switches 420 on both sides of a communication 1000. For instance, the traffic scenario of FIG. 10K is applicable whenever both sides of a communication are transported on a broadband transport mechanism such as ATM.

In FIG. 10G, a communication 1050 is terminated at the incoming (e.g., TDM) side by the narrowband portion of the hybrid switch 420. The switching of the communication 1050 may be performed by both the narrowband and the broadband portions after accommodation of the differing formats (e.g., by a circuit emulation board). The termination of the outgoing (e.g., ATM) side of the communication 1050 is effectuated (e.g., by an exchange termination (ET) board) at the broadband portion of the hybrid switch 420. In FIG. 10H, the incoming side of a communication 1060 is terminated (e.g., by a circuit emulation board for a narrowband transport format) at the broadband portion of the hybrid switch 420. Switching of the communication 1060 may be performed entirely within the switching fabric of the broadband portion of the hybrid switch, and termination (e.g., by an exchange termination board for a broadband transport format) of the outgoing side of the communication 1060 may be accomplished by the broadband portion as well.

In FIG. 10I, the incoming side of a communication 1070 is terminated (e.g., by an exchange termination board for a broadband transport format) at the broadband portion of the hybrid switch 420. Switching of the communication 1070 may be performed entirely within the switching fabric of the

broadband portion of the hybrid switch 420, and termination (e.g., by a circuit emulation board for a narrowband transport format) of the outgoing side of the communication 1070 may be accomplished by the broadband portion as well. In FIG. 10J, a communication 1080 is terminated at the incoming (e.g., ATM) side by the broadband portion of the hybrid switch 420 (e.g., using an exchange
5 termination board). The switching of the communication 1080 may be performed by both the narrowband and the broadband portions after accommodation of the differing formats (e.g., by a circuit emulation board). The termination of the outgoing (e.g., TDM) side of the communication 1080 is effectuated at the narrowband portion of the hybrid switch 420.

In FIG. 10K, the hybrid switch may act as a "pure transit node" for ATM connections, such as
10 the illustrated portion of the communication 1000, which is denoted as a communication 1090. Both of the incoming and the outgoing sides of the communication 1090 are terminated by the broadband portion of the hybrid switch 420 (e.g., by two exchange termination boards). Also, the communication 1090 may be switched entirely by the switching fabric (e.g., as realized by an ATM switch 630) of the broadband portion of the hybrid switch 420. As also described and alluded to with reference to, for
15 example, FIG. 6 hereinabove, a hybrid switch 420 may establish various connection paths within to thereby enable a myriad of combinations of external ingress points and external egress points for different types of communications. The hybrid switch 420 may thus receive and forward communications 1000 in any combination of incoming and outgoing narrowband and broadband formats to accommodate, for example, the next node along the communication path, a node that is
20 proximal to the final destination of the communication 1000, etc.

Referring now to FIG. 11, an exemplary outgoing communication format selection for a hybrid switch in accordance with the present invention is illustrated generally at 1100. An incoming communication 1105 is illustrated as being either broadband (e.g., ATM formatted) or narrowband (e.g., TDM formatted). The hybrid switch 420, as described hereinabove with reference to FIGS.
25 10A-10K, for example, may forward the communication 1105 as either an ATM communication or a TDM communication. (It should be understood that an outgoing TDM communication may be terminated by either the narrowband portion or the broadband portion of the hybrid switch 420. However, this detail is not directly addressed further in the context of FIG. 11.) The hybrid switch 420 may forward the communication on the outgoing side according to any of various algorithms. For
30 example, the hybrid switch may forward all incoming communications 1105 as outgoing TDM communications 1115 (e.g., if the hybrid switch 420 is the first or one of the first hybrid switches to be installed in a traditionally narrowband network) or as outgoing ATM communications 1120 (e.g., if

the hybrid switch 420 is the last or one of the last hybrid switches to be installed in a formally narrowband network). Refer also to the text hereinabove describing FIG. 3H.

Alternatively, the hybrid switch 420 may consult a table 1110 that provides an indication as to the viability and/or desirability of forwarding the communication 1105 in either a broadband or a narrowband format. For example, the table 1110 may indicate whether a node associated with the destination terminal 1155 or 1170 is capable of broadband transport. The table 1110 may also or in the alternative indicate whether any nodes between the hybrid switch 420 and the destination terminal 1155 and 1170 are capable of broadband transport. An exemplary embodiment for table 1110 is discussed hereinabove with reference to, for example, FIG. 3A, Events E8 and E9, and may involve the ascertainment of the bearer type (of either or both of the incoming side of the communication and the destination terminal). It should be noted that the table 1110 may be realized, instead of being part of the narrowband portion of the hybrid switch 420 but separate from the GS as illustrated, as part of the GS (e.g., the GS 615), as any part of the broadband portion (e.g., the ATM switch 630), as another part of the hybrid switch 420, or even at an external location (e.g., an IN node), etc.

Alternatively, instead of relying on information in a table 1110, the hybrid switch may query a node at or proximate to the destination node, may send a test signal/communication, etc. Regardless, if the hybrid switch 420 determines that there is a broadband node associated with the destination terminal, the hybrid switch 420 may elect to forward the incoming communication 1105 as a broadband (e.g., ATM) communication 1120. The hybrid switch 420 receives the incoming broadband communication 1120 and forwards an outgoing narrowband (e.g., TDM) communication 1160 to a local exchange node 1165 (e.g., which may correspond to, for example, an access node 322, etc. of FIGS. 3 et seq.), which connects to the destination terminal 1170 (e.g., which may correspond to, for example, a terminal 324, etc. of FIGS. 3 et seq.).

If, on the other hand, the hybrid switch 420 determines that there is not a broadband node associated with the destination terminal, the hybrid switch 420 may elect to forward the incoming communication 1105 as a narrowband (e.g., TDM) communication 1115. However, the hybrid switch 420 may optionally include provisions for determining that one or more (e.g., a sufficiently high enough number of intervening nodes have broadband capability, a sufficiently shorter route may be defined across intervening broadband-enabled network nodes, etc.) intervening broadband nodes may be advantageously utilized along the overall communication path. If such a determination is made, the hybrid switch 420 may elect to forward the incoming communication 1105 as a broadband (e.g., ATM) communication 1125 through a broadband-enabled network portion 1130. Regardless, the

communication is or ultimately becomes/is converted to a narrowband (e.g., TDM) communication and is submitted as narrowband communication 1135 to the narrowband node 1140. The narrowband node 1140 forwards the incoming narrowband communication 1135 as an outgoing narrowband (e.g., TDM) communication 1145 to a local exchange 1150 (e.g., which may correspond to, for example, an access node 322, etc. of FIGS. 3 et seq.), which connects to the destination terminal 1155 (e.g., which may correspond to, for example, a terminal 324, etc. of FIGS. 3 et seq.).

Referring now to FIG. 12, exemplary interactions between a hybrid switch and other telecommunications technology in accordance with the present invention are illustrated generally at 1200. The hybrid switch 420 of 1200 illustrates the traffic scenarios or communication portions 1010-1090 of communication 1000 (of FIGS. 10A-10K). Communication 1205 (illustrated generally as a line or loop) enables a communication 1010-1090 according to any of the various traffic scenarios to access telecommunications technology using TDM communication and a STM switch (e.g., a GS 615). For example, one or more IN nodes 815 of an IN (not explicitly shown in FIG. 12) may be accessed via the communication 1205. Many telecommunications services and features may be utilized by accessing the IN. A DTMF receiver 1210, for example, may be accessed for password and account number reception and for sending announcements from the IN. Generally, specialized resource function (SRF) and service control function (SCF) features are accessible via the IN node 815. These and other IN features are represented generally by the other block 1215. Access to the IN node 815 may be accomplished during the call establishment phase. Thereafter, routing of the communication 1000 may optionally be maintained through the narrowband portion of the hybrid switch 420. Regardless, the communication 1000 may be routed through the narrowband portion (e.g., the GS 615) during an active call phase in order to access IN features.

The communication 1205 may also enable access to the operator 1220 for the communication 1000 (of FIGS. 10A-10K). The operator 1220 may handle the telecommunications situation and thereafter route the connection further along communication 1205 to implement one of the illustrated traffic scenarios. Alternatively (e.g., depending on how the operator 1220 handles the telecommunications situation), the operator 1220 may independently forward the connection towards, e.g., another exchange as indicated by arrow 1225. The communication 1205 may also enable access to legal intercept (LI) equipment 1230. It should be noted that with respect to FIG. 12, as well as other FIGS. described herein, certain elements may be moved, changed in number, etc. without departing from the scope of the present invention. For example, with regard to the hybrid switch 420 of FIG. 12, only two ET equipments may be associated with the GS (instead of the four illustrated), and the CE

equipment between the GS and the ATM switch may be more closely associated with the ATM switch than the GS (e.g., as illustrated in FIG. 11).

The hybrid nature of the hybrid switch 420, in addition to enabling a gradual migration from a narrowband-oriented network to a broadband-oriented network, also enables seamless integration with
5 networks of other carriers, networks of mobile systems, and networks that are international (all of which are designated generally by the external networks 1240). The external networks 1240 currently operate in accordance with TDM principles (or at least they are designed to interface with other networks using TDM principles), and they may continue to do so for quite some time into the future. The hybrid switch 420, while providing the ability to transport communications on a broadband
10 transport mechanism, also maintains the ability to utilize a narrowband transport mechanism and the ability to interface with external networks 1240 using traditional protocols. For example, communication 1205 enables outgoing connections (as represented by arrow 1235) and incoming connections (as represented by arrow 1245) between the hybrid switch 420 and the external networks 1240.

Referring now to FIG. 13, an exemplary traffic scenario migration for a hybrid switch in accordance with the present invention is illustrated generally at 1300. The hybrid switch 420 may be "installed" in an existing network that utilizes, at least primarily, a narrowband transport mechanism. The hybrid switch 420 may be "installed", for example, by augmenting an existing TDM switch with ATM switching fabric. When the hybrid switch 420 is initially installed, especially if it is one of the
20 first such switches installed, the hybrid switch may be activated or set up to operate entirely or predominantly within a first exemplary mode. Such a first exemplary mode may entail receiving a communication 1305 (e.g., as incoming TDM) and forwarding the communication 1305 (e.g., as outgoing TDM) using the switching fabric (e.g., a GS 615) of the existing narrowband switch. Gradually, as additional broadband-enabled nodes are "brought on-line", the hybrid switch 420 may
25 enter a second exemplary mode. Such a second exemplary mode may entail receiving a communication 1310 (e.g., as incoming TDM) and forwarding the communication 1310 (e.g., as outgoing ATM) using the switching fabric of the existing narrowband switch as well as the switching fabric (e.g., an ATM switch 630) of the broadband switch.

As the hybrid switch 420 of 1300 begins to receive incoming communications that use a
30 broadband transport mechanism such as ATM, the hybrid switch 420 may enter a third exemplary mode. Such a third exemplary mode may entail receiving a communication 1315 (e.g., as incoming ATM) and forwarding the communication 1315 through the switching fabric of the broadband switch

and the switching fabric of the narrowband switch to be handled by narrowband telecommunications technology and/or telecommunications technology with narrowband interface(s). For example, the communication 1315 may be forwarded from the narrowband switch as communication 1315' to a voice response unit 1320 to provide voice response service to the communication 1315 that originally arrived at the hybrid switch 420 using a broadband transport mechanism. Alternatively, the communication 1315 may be forwarded from the narrowband switch as communication 1315" (as indicated by the arrow so labeled) to external network(s) 1240. If the communication 1315 is to continue within the network of the hybrid switch 420 (or otherwise forwarded as a broadband connection therefrom), the communication 1315' is returned to the narrowband switching fabric (e.g., after being serviced by the voice response unit 1320 or other such existing narrowband features) and forwarded to and through the broadband switching fabric as the communication 1315' (e.g., as outgoing ATM).

Eventually, as the network becomes wholly or primarily a broadband transport mechanism network (optionally including broadband provision of IN-type services, etc.), the hybrid switch 420 of 1300 may enter a fourth exemplary mode. Such a fourth exemplary mode may entail receiving a communication 1325 (e.g., as incoming ATM) and forwarding the communication 1325 (e.g., as outgoing ATM) using the switching fabric of the broadband portion of the hybrid switch 420. It should be understood that the four modes illustrated and described herein with reference to FIG. 13 are exemplary only. Modes may be added, subtracted, or substituted for the four exemplary modes depending, for example, on the percentage of the network that has been upgraded to broadband. Furthermore, the modes may be activated in a different order depending, for example, on whether or not the hybrid switch in question is a "transit-type" node.

Referring now to FIG. 14, an exemplary method in flowchart form for enabling a gradual migration from a primarily narrowband network to a primarily broadband network in accordance with the present invention is illustrated generally at 1400. Initially, a network node (e.g., a hybrid switch 420) receives an incoming communication that includes an identifier corresponding to a destination terminal (e.g., a destination terminal 1155 and 1170 (of FIG. 11)) (step 1405). The incoming communication may be transported, for example, on a broadband or narrowband mechanism. The identifier that corresponds to the destination terminal is analyzed (step 1410). The identifier may correspond to, for example, a B-number, and the identifier may be analyzed, for example, in a narrowband portion of the network node. The analysis may include a determination as to whether or not the identifier is associated with a node having broadband capability (step 1415). If not, then the

communication may be forwarded over a narrowband transport mechanism (step 1420) and ultimately to the destination terminal.

If, on the other hand, it is determined that the identifier is associated with a node having broadband capability (at step 1415), then the communication may be forwarded over a broadband transport mechanism (step 1425) and ultimately to the destination terminal. The identifier may be associated with a node when, for example, the node is the most proximate node (or the most proximate non-local exchange and/or non-end office node) to the destination terminal. The identifier, in addition to or in the alternative, may be associated with a node when the node is somewhere between the analyzing node and the destination terminal, but the node is sufficiently far from the analyzing node and sufficiently close to the destination terminal so as to warrant diverting (if necessary) the communication onto a broadband transport mechanism. The analysis may involve accessing a table (or other data structure) (e.g., a table 1110), which may be gradually updated as nodes in the network are upgraded to provide broadband transport. In an alternative embodiment, a communication may only be forwarded using a broadband transport mechanism (e.g., in step 1425) if a node having broadband capability is also associated with an identifier that corresponds to an originating terminal and/or if the incoming communication "arrives" over a broadband transport mechanism. In yet another alternative, the broadband capability of a node associated with the identifier that corresponds to the originating terminal may be another factor to account for when analyzing the proximity of the node associated with the identifier of the destination terminal. A hybrid switch operated in accordance with certain principles of the present invention therefore enables a gradual migration from a narrowband-oriented network to a broadband transport mechanism-oriented network.

Referring now to FIG. 15, an exemplary tri-level nodal environment in accordance with the present invention is illustrated generally at 1500. A call/connection control node 405 (e.g., which may correspond to, for example, PSTN/ISDN nodes 330 of the embodiment(s) of FIGS. 3 et seq.) is illustrated connected to a modified connection control node 410' (e.g., which may correspond to, for example, ATM node 340₇₋₁ of the embodiment(s) of FIGS. 3 et seq.) via line 1510 (e.g., which may correspond to, for example, interface 300a and/or interface 300d of the embodiment(s) of FIGS. 3 et seq.). The modified connection control node 410', in the exemplary tri-level nodal environment 1500, includes an interworking function (IWF) 1505 (e.g., which may correspond to, for example, an IWF 344₇₋₁ of the embodiment(s) of FIGS. 3 et seq.). The IWF 1505 may be composed of, for example, hardware, software, firmware, some combination thereof, etc.

The IWF 1505 may include emulation and mapping capabilities. For example, the IWF 1505 may include the ability to emulate a switch interface for the call/connection control node 405. Advantageously, this eliminates any absolute requirement to modify the call/connection control node 405 because the call/connection control node 405 is able to act and interact as if it is functioning within a traditional telecommunications network. The IWF 1505 may also include the ability to map/translate one network address into or to another network address. The modified connection control node 410' is illustrated connected to multiple connection control nodes 410 (e.g., which may correspond to, for example, ATM node 340_{7,2}, ATM node 340_{7,3}, etc. of the embodiment(s) of FIGS. 3 et seq.) via lines 1515 (e.g., which may correspond to, for example, interfaces 300a and/or interfaces 398 of the embodiment(s) of FIGS. 3 et seq.). In the exemplary tri-level nodal environment 1500, the call/connection control node 405 may advantageously provide/share its switching intelligence with more than one connection control node 410. It should be understood that the various nodes may be physically co-located, physically separated, etc.

Referring now to FIG. 15A, a first exemplary tri-level nodal environment alternative in accordance with the present invention is illustrated generally at 1525. In the first exemplary tri-level nodal environment alternative 1525, the call/connection control node 405 is in communication with the modified connection control node 410' via a first line 1530 and a second line 1535. The first line 1530 and the second line 1535 may be used for communicating signaling information and data information, respectively, between the call/connection control node 405 and the modified connection control node 410', which has the IWF 1505. Also illustrated in the first exemplary tri-level nodal environment alternative 1525 is an ATM network 215 cloud interconnecting the modified connection control node 410' and the connection control nodes 410. In other words, the modified connection control node 410' need not employ direct and dedicated links to the individual connection control nodes 410. It should be understood that the ATM network 215 may alternatively be realized as any circuit-switched network.

Referring now to FIG. 15B, a second exemplary tri-level nodal environment alternative in accordance with the present invention is illustrated generally at 1550. In the second exemplary tri-level nodal environment alternative 1550, a "streamlined" tri-level nodal environment is illustrated. The modified call control node 405' does not include connection control (e.g., it was designed and built without such connection control, it had its connection control removed or rendered inoperable, etc.), and no single connection control is directly associated with (or co-located with) the IWF (node) 1505. The switching intelligence of the modified call control node 405' operates in a first address

space, which is designated address space A 1555. The switching fabric of the multiple connection control nodes 410, on the other hand, operate in a second address space, which is designated address space B 1560. The IWF 1505 maps/translates the addresses of the address space A 1555 to the addresses of the address space B 1560 so as to enable the switching intelligence of the modified call control node 405' to provide call control to the switching fabric of the multiple connection control nodes 410.

It should be understood that while the address spaces A 1555 and B 1560 are illustrated only in the second exemplary tri-level nodal environment alternative 1550, they are also applicable to the exemplary tri-level nodal environment 1500 as well as the first exemplary tri-level nodal environment alternative 1525. It should also be understood that the different aspects illustrated in the various embodiments of FIGS. 15, 15A, and 15B may be interchanged without departing from the present invention. For example, a circuit-switched network cloud (e.g., the ATM network 215) may interconnect the multiple connection control nodes 410 in any or all embodiments embraced by the present invention.

Referring now to FIG. 15C, an exemplary interworking function in accordance with the present invention is illustrated at 1505. The IWF 1505 includes an emulator 1580 and a mapper (or translator) 1585. The emulator 1580 emulates an interface to which the call/connection control node 405 "expects" to be connected. In other words, the emulator 1580 may provide an interface that the call/connection control node 405 is already designed to utilize and/or interact with. Advantageously, this eliminates or minimizes or at least reduces the need to modify the call/connection control node 405. It should be noted that the interface may be equivalent to a GS input/output (I/O), E1/T1 trunk lines, etc. The mapper 1585 provides a mapping (or more generally a correspondence) between addresses of a first address space and addresses of a second address space.

The mapper may map (or more generally a correspondence may be established between) address space A 1555 (of FIG. 15B) to the address space B 1560. For example, one or more of the addresses A1... An of the address space A 1555 may be mapped to one or more of the addresses B1... Bn of the address space B 1560. As a specific instance, the address A3 may be mapped to the address B1. In exemplary embodiment(s), the address space A 1555 may include 10-digit B-numbers, and the address space B 1560 may include ATM identifiers such as VPIs and VCIs. Other exemplary address space realizations are also embraced by the present invention.

Referring now to FIG. 16, an exemplary tri-level nodal environment implementation in accordance with the present invention is illustrated generally at 1600. A telecommunications node

(TN) 1605 (e.g., which may correspond to, for example, a call/connection control node 405 of the embodiment(s) of FIGS. 15 et seq.) is shown connected to media gateway functionality 1610 (e.g., which may correspond to, for example, a modified connection control node 410' of the embodiment(s) of FIGS. 15 et seq.). The TN (a.k.a. legacy switch (LS)) 1605 may have a circuit switch such as a GS 615 (not explicitly shown in FIG. 16). The media gateway functionality 1610 may include a media gateway (MG) 1615, which may have a packet switch such as an ATM switch 630, and mediation logic (ML) 1620 (e.g., which may correspond to, for example, an IWF 1505 of the embodiment(s) of FIGS. 15 et seq.).

The media gateway functionality 1610 is illustrated as being connected to multiple MGs 1625 (e.g., which may correspond to, for example, the multiple connection control nodes 410 of the embodiment(s) of FIGS. 15 et seq.). Each of the MGs 1625 may be responsible for handling one or more different types of media. The media, and nodes corresponding thereto, may include, for example, a remote subscriber switch (RSS) node 1630A, a V5.2 interface access network (V5.2) node 1630B, a local exchange (LE) node 1630C, a primary rate access (PRA) node 1630D, etc. An MG 1625 (or an MG 1615) may convert media provided in one type of network to the format requirements of another type of network.

Exemplary and/or appropriate protocols for the links between the various illustrated nodes (including the gateways) are illustrated at the exemplary tri-level nodal environment implementation 1600. As an explanatory example, the connections between the media gateway functionality 1610 and the multiple MGs 1625 may be ATM-ET to ATM-ET PVPC pipes defined through an ATM network to carry signaling information. A PVPC is an ATM connection in which the switching is performed only on the VPI field of each cell. A PVPC is termed "permanent" because it is provisioned through a network management function and maintained (or left up) indefinitely. The signaling information between the media gateway functionality 1610 and any one or more of the MGs 1625 may be effectuated transparently over a PVPC pipe. Such a PVPC pipe is at least similar to one establishable through the switching fabric of a connection control node 410 for transparently piping signaling information to the switching intelligence of a call/connection control node 405 (as alluded to hereinabove with reference to FIGS. 3 et seq.).

Referring now to FIGS. 17A and 17B, two other exemplary tri-level nodal environment implementations in accordance with the present invention are illustrated generally at 1700 and 1750, respectively. The exemplary tri-level nodal environment implementations 1700 and 1750 include call servers 1705. The call servers 1705 each include a TN 1605 and ML 1620. Each call server 1705 may

control one or more MGs 1625 (denoted as "MGW" in FIGS. 17A and 17B) via the packet-switched network cloud, such as an ATM network 215. Each call server 1705, being based on pre-existing TNs 1605 in certain exemplary embodiment(s), may only handle a finite number of MGs 1625. Accordingly, a given tri-level nodal environment may need more than one call server 1705, as indicated by the two call servers 1705 illustrated in the exemplary tri-level nodal environment implementation 1750.

The bearer services for call data information are provided by the packet-switched broadband network (e.g., via encapsulation), and the telecommunications services/call control may be transported over this packet-switched (broadband) network in an un-modified format (e.g., transparently in pipes), as indicated by the dashed lines. For example, control communications to the private branch exchange (PBX) nodes 1710A are effectuated using DSS1, control communications to the generic access nodes (AN) 1710B are effectuated using V.5, and control communications to the LE nodes 1630C are effectuated using ISUP. Likewise or similarly, the two call servers 1705 may communicate therebetween using a bearer independent call control (BICC) protocol that may be transported over the packet-switched network. It should be emphasized that TDM as used herein, including the claims, encompasses and embraces time-division multiplexed protocols in general, and it is not limited to any particular TDM protocol, including the exemplary 2M PCM link definition of FIGS. 17A and 17B.

With reference now to FIGS. 18A and 18B, two exemplary call setups in an exemplary tri-level nodal environment implementation in accordance with the present invention are illustrated generally at 1800 and 1850, respectively. In the exemplary call setup 1800, a TN 1605 determines that a communication path between points A and B are needed for a call. The TN 1605 therefore instructs the ML 1620 to establish a path between the points A and B. The instruction may include direction(s) for establishing such a path in a TDM network. The ML 1620, applying the points A and B and/or the direction(s) to a mapping data structure for example, determines how to establish a communication path between points A and B. The ML 1620 then instructs/requires that such a communication path be established (e.g., added) in the broadband network of which the MG 1625 is a part. In the exemplary call setup 1800, an intra MG call setup case is illustrated, so the single MG 1625 that is illustrated is capable of establishing the communication path.

In the exemplary call setup 1850, on the other hand, a multi-MG (but intra domain) call setup case is illustrated, so more than a single MG 1625 is required to establish the communication path. Specifically, after the ML 1620 receives the instruction (and possibly the direction(s)) from the TN 1605, the ML 1620 determines that the communication path needs to extend between at least two MGs

1625. Namely, the MGs 1625 that include the points A and B need to be interconnected, optionally with no intervening MG(s) 1625. In the exemplary call setup 1850, the ML 1620 then instructs/requires that such an interconnection for the communication path be established (e.g., added) in the broadband network between the MG 1625AC' and the MG 1625D'B, as indicated by the dashed
5 line. The MGs 1625AC' and 1625D'B also complete the communication path between point A and point B by establishing interconnections between points A and C' and points D' and B, respectively. By determining a communication path and/or instituting a routing of a communication path between point A and point B through a packet-switched (broadband) network, the ML 1620 effectively maps from one address space to another address space.

10 Referring now to FIG. 19, exemplary communication path configuring in an exemplary tri-level nodal network in accordance with the present invention is illustrated generally at 1900. The entities responsible for configuring various communication paths in the exemplary tri-level nodal network 1900 are indicated by the type of line (e.g., solid, dashed, thick, thin, etc.) illustrating/representing the particular communication path. The signaling link parts represented by
15 the solid thick lines (also labeled "(A)") are configured by TN 1605 commands. The signaling link parts represented by the solid thin lines (also labeled "(B)") are configured by ATM management system commands. The leased line parts represented by the dashed thick lines are configured by TN 1605 commands. The leased line parts represented by the dashed thin lines (also labeled "(C)" and "(D)") are configured by ATM management system commands. The parts labeled "(A)" and "(C)"
20 pertain to intra-domain segments while the parts labeled "(B)" and "(D)" pertain to inter-domain segments. It should be noted that segments within the ATM network are configured by the ATM management system commands while segments extending beyond the ATM network are configured by TN 1605 commands in the exemplary communication path configuring of the exemplary tri-level nodal network 1900.

25 Referring now to FIGS. 20A and 20B, exemplary mapping embodiments in an exemplary tri-level nodal environment implementation in accordance with the present invention are illustrated generally at 2000 and 2050, respectively. The exemplary mapping as illustrated at 2000 includes a man machine line (MML) handler 2005 and an ATM management system 2010 that enable the general management of the illustrated tri-level nodal environment implementation. Specifically, the MML
30 handler 2005 enables the configuring of the TN 1605 portion, and the ATM management system 2010 enables the configuring of the ML 1620 and MG 1625 portions. Switch device management (SDM) parts 2015TN and 2015ML enable communication between the TN 1605 and the ML 1620, along with

the transport handler (TRH) 2020. In exemplary embodiment(s), a switch device (SD) may correspond to a logical device that terminates a 31 channel logical E1 line. A context handler 2025 enables communication from/to the ML 1620 to/from the ATM network.

In exemplary embodiment(s), an H.248 protocol may be employed for communication over
5 the ATM network. A mapping part portion 2030 stores the topology of one or more MGs 1625 as well as a protocol mapping of the SDM part(s) (e.g., of the circuit-switched address space) to the H.248 (e.g., of the packet-switched address space). The exemplary mapping as illustrated at 2050 includes indications of an add port instruction 2055 and an add port response instruction 2060 exchanged
10 between the TN 1605 and the ML 1620. These instructions, which may originate at the MML terminal 2005, configure the mapping providing by the H.248 table 2065 and the SD table 2075. The H.248 table 2065 and the SD table 2075 together provide a mapping between H.248 addresses (e.g., an "MG/Subrack/Slot/Port" address) and SD addresses (e.g., and "SD1" address).

It should be noted that the H.248 addresses may have an unrestricted and/or unstructured format that differs from and may be more flexible than the "MG/Subrack/Slot/Port" as illustrated in
15 FIG. 20B. In fact, an operator may be empowered to select such names. The MG 1625 includes an H.248 object table 2080, which may be configured at least in part by the ATM management system 2010, for establishing communication paths through the MG 1625. The tri-level approach described hereinabove in various embodiments enables pre-existing narrowband technology to be used with broadband technology. Moreover, the tri-level approach multiplies the ability to reuse a pre-existing
20 narrowband switch by enabling a single narrowband switch to provide switching intelligence to multiple broadband switches.

Referring now to FIG. 21, an exemplary tri-level nodal environment in accordance with the present invention is illustrated generally at 2100. The exemplary tri-level nodal environment 2100 includes two or more telecommunications nodes (TN) 2105 (e.g., which may correspond to, for
25 example, the PSTN/ISDN node 330 of FIGs. 3 et seq., the call/connection control node 405 of FIGs. 4 et seq. and/or the TN 1605 of FIGs. 17 et seq.). All of the TNs 2105 are connected to one or more mediation logic (ML) nodes 2115 (e.g., which may correspond to, for example, the ML 1620 of the embodiment(s) of FIG. 16 et seq.). The ML 2115 is controlled by all of the TNs 2105.

The ML 2115 is further connected to a broadband network (BN) 2125 (e.g., which may
30 correspond to, for example, the ATM network 215 of the embodiment(s) of FIG. 4 et seq.). The BN 2125 provides a medium for the ML 2115 to be in communication with one or more media gateways (MGs) 2120 (e.g., which may correspond to, for example, the MGs 1625 of the embodiment(s) of FIG.

16 et seq.). It should be understood that the architecture illustrated in the exemplary tri-level nodal environment 2100 may be modified, rearranged, etc., especially in accordance with the other illustrated and described embodiments and teachings from FIGS. 15-15C, as well as those of FIGS. 16-20B. For example, the ML 2115 may include a co-located MG 2120 for call connection between
5 the TN 2105 and the BN 2125.

Referring now to FIG. 22, to support multiple TNs 2105 connected to one or more ML 2115, the transport handler (TRH) 2200 (e.g., which may correspond to, for example, the TRH 2020 of FIGS. 20A and 20B) within the ML 2115 and TNs 2105 is updated to provide an identifier 2250 with each message 2220 sent between the TNs 2105 and the ML 2115. Messages 2220 sent between the TNs
10 2105 and the ML 2115 are transported over Ethernet control links utilizing the Internet Protocol (IP). Therefore, each message 2220 includes an IP address for the destination node (e.g., which can be, for example, a control processor within the ML 2115). The third octet of the IP address uniquely identifies the switch (e.g., TN 2105 or ML 2115) associated with the destination node.

The TRH 2250 in both the TN 2105 and the ML 2115 has access to the third octet of the IP
15 address for each message 2220, and therefore can prepend the source (message sending node) identifier 2250, along with the destination (message receiving node) identifier (not shown) to the message 2220. The destination identifier is retrieved from the third octet of the IP address. By prepending the message 2220 with the source identifier 2250 and destination identifier, the message 2220 parameters remain unchanged. However, the destination node must strip off the identifiers 2250
20 before processing the message 2220. Therefore, in other embodiments, the TRH 2200 can add an additional parameter to the message 2220 that includes the source identifier 2250.

Referring now to FIGS. 23A and 23B, in addition to including at least a source identifier with each message (e.g., an AddPort message 2350 or AddPortRes message 2355) between the ML 2115 and the TNs 2105, the mapping of switch device (SD) addresses 2320 (e.g., which may correspond to,
25 for example, the switch device addresses within the SD table 2075 of FIG. 20B) to MG port addresses 2310 (e.g., which may correspond to, for example, the H.248 addresses within the H.248 table 2065 of FIG. 20B) must be extended to support more than one TN 2105. Therefore, upon receipt of an AddPort message 2350 (e.g., which may correspond to, for example, the add port instruction 2055 of FIG. 20B) that includes the TN (source) identifier, the ML 2115 stores the TN identifier 2250 against
30 the assigned SD 2320 in the SD Table 2325. The TN identifier 2250 is also used for processing other messages, such as an AuditPort message, where the TN identifier sent with the AuditPort message is

-48-

checked against the TN identifier 2250 stored with the SD 2320 associated with the MG port 2310 to confirm that the requesting TN 2105 has the authority to request an audit of that MG port 2310.

In exemplary embodiments, the SD address 2320 identifies a logical device that terminates a 31 channel logical E1 line of the TN 2105. The SD address 2320 (e.g., circuit switched address) is mapped to a BN address 2310 (e.g., packet-switched address) by associating the assigned SD address
5 mapped to a BN address 2310 (e.g., packet-switched address) by associating the assigned SD address 2320 in the SD table 2325 with a MG port address 2310 in a BN table 2305 (e.g., which may correspond to, for example, the H.248 table 2065 of FIG. 20B). The MG port address 2310 represents the logical E1 line of the TN 2105, and is associated with a real port of a MG in the BN.

As shown in FIG. 23B, in order to establish connections between TNs 2105 sharing the same
10 ML 2115, an address 2315 for a MG logical port (not shown) is stored in the BN table 2305. The MG logical port address 2315 is associated with two real ports of one or more MG's in the BN. In addition, the MG logical port address 2315 represents a logical E1 path between the two TNs 2105. For both TNs 2105 to own a particular logical port, the TN identifier 2250 of both TNs 2105 is stored against the address 2320 of the SD associated with the logical port address 2315 in the SD table 2325.

FIG. 24 illustrates an exemplary method in flowchart form for mapping between address
15 spaces in the tri-level nodal environment of FIG. 21 in accordance with the present invention. When a first telecommunications node (TN1) sends an AddPort message for a particular logical port (LP1) to the ML (step 2400), the ML assigns LP1 to TN1 (step 2410) by storing the identifier for TN1 against the SD associated with LP1. In response, the ML sends an AddPortRes message to TN1 (step 2420)
20 that includes at least the assigned SD address.

If a second telecommunications node (TN2) sends an AddPort message for LP1 to the ML
(step 2430), the ML checks LP1 to ensure that two TNs are not already assigned to LP1, and if not, the ML assigns LP1 to TN2 (step 2440) by storing the identifier for TN2 against the SD associated with LP1. In response, the ML sends an AddPortRes message to TN2 (step 2450) including at least the
25 assigned SD address. Before TN2 sends the AddPort message (step 2430), if TN1 sends a ReleasePort message to the ML (step 2460), the ML releases LP1 (step 2470) by removing the identifier associated with TN1 from the SD associated with LP1. It should be noted that TN1 can send a ReleasePort message at any time, without affecting the assignment of LP1 to TN2, and vice-versa.

FIG. 25 illustrates a further exemplary mapping embodiment in the exemplary tri-level nodal
30 environment of FIG. 21 in accordance with the present invention. When an AddPort message 2350 is received specifying a particular logical port (LP1), the switch device management (SDM) 2500 (e.g., which may correspond to, for example, the SDM 2015 of FIG. 20A) within the ML 2115 assigns a

particular call handler (CH) 2510 based on the subrack value for LP1 included within the AddPort message 2350. The slot and interface values for LP1 included within the AddPort message 2350 are used by the SDM 2500 to determine LP1 2515. It should be noted that both the slot and interface parameters have 100 possible values each, thus creating up to 10,000 unique logical ports 2515 per CH 2510. The SDM 2500 further selects a SD 2520 for LP1 2515 and passes the SD address and CH address back to the TN 2105 that sent the AddPort message in the AddPortRes message 2355.

Referring now to FIG. 26, to establish a connection between two TNs 2105a and 2105b sharing the same ML 2115, each TN 2105a and 2105b sends a separate EstablishPath message 2600a and 2600b, respectively, to the ML 2115. Each EstablishPath message 2600a and 2600b requests a logical path 2650a and 2650b, respectively, be setup between the logical port (LP1) 2515 owned by both TN 2105a and TN 2105b and a real port (RP1 or RP2) in the BN 2125. For example, the EstablishPath message 2600a sent by TN 2105a requests a logical path 2650a from LP1 to RP1 associated with MG 2120a, whereas the EstablishPath message 2600b sent by TN 2105b requests a logical path 2650b from LP1 to RP2 associated with MG 2120b.

Therefore, each TN 2105a and 2105b separately defines semi-permanent connections 2650a and 2650b through the ML 2115. After both semi-permanent connections are defined, PVC connections 2650a and 2650b can be established. Furthermore, after both logical paths 2650a and 2650b are setup, the ML 2115 realizes that real ports (RP1 and RP2) are on the end points of the logical paths 2650a and 2650b and establishes a physical connection 2660 from RP1 to RP2 over the BN 2125, while maintaining the logical paths 2650a and 2650b involving LP1. The resources used in LP1 2515 for the call connection are maintained until the connection is removed by a ReleasePath message (not shown).

FIG. 27 illustrates an exemplary method in flowchart form for establishing a connection between two TNs sharing the same ML. When a first telecommunications node (TN1) sends an EstablishPath message for LP1 and RP1 to the ML (step 2700), the ML establishes a logical path between LP1 in the ML and RP1 in the BN (step 2710). Thereafter, if a second telecommunications node (TN2) sends an EstablishPath message for LP1 and RP2 to the ML (step 2720), the ML establishes a logical path between LP1 and RP2 (step 2730), and a physical connection between RP1 and RP2 over the BN (step 2740).

However, if before TN2 sends the EstablishPath message (step 2720), TN1 sends a ReleasePath message to the ML (step 2750), the ML releases the logical path from LP1 to RP1 and releases resources reserved in LP1 for the call (step 2770). In addition, if TN2 does not send the

-50-

EstablishPath message to the ML (step 2720) before the expiration of a predefined time period (step 2760), the ML releases the logical path from LP1 to RP1 and releases resources in LP1 reserved for the call (step 2770).

5 Although embodiment(s) of the methods, systems, and arrangements of the present invention have been illustrated in the accompanying Drawings and described in the foregoing Detailed Description, it will be understood that the present invention is not limited to the embodiment(s) disclosed, but is capable of numerous rearrangements, modifications, and substitutions without departing from the spirit and scope of the present invention as set forth and defined by the following claims.

10

WHAT IS CLAIMED IS:

1. An interworking node operatively connectable to a plurality of call control nodes each including switching intelligence and narrowband switching fabric and a plurality of connection control nodes each including broadband switching fabric, said interworking node comprising:
5 means for interworking between said plurality of call control nodes and said plurality of connection control nodes; and
means for receiving messages from said plurality of call control nodes, each of said messages including an identifier associated with one of said plurality of call control nodes, each of said
10 messages controlling said interworking means.
2. The interworking node of Claim 1, wherein said means for interworking comprises:
a plurality of resources for interworking between said plurality of call control nodes and said
15 plurality of connection control nodes, an assigned one of said plurality of resources having said identifier of at least one of said call control nodes associated therewith.
3. The interworking node of Claim 2, wherein said assigned resource comprises a logical port for supporting connections between two of said plurality of call control nodes, said logical port having
20 said identifier of said two call control nodes associated therewith.
4. The interworking node of Claim 3, wherein said logical port represents a logical E1 path between said two call control nodes.
5. The interworking node of Claim 4, wherein said assigned resource further comprises a call
25 handler within said interworking node, said logical port being handled by said call handler.
6. The interworking node of Claim 5, wherein said assigned resource further comprises a switch device within said interworking node, said switch device being a logical device that corresponds to the logical E1 path between said two call control nodes.
30
7. The interworking node of Claim 6, wherein said means for interworking further comprises: a mapping function for mapping an address for said switch device to an address for said logical port.

-52-

8. The interworking node of Claim 3, wherein said means for interworking further comprises: means for establishing logical paths between said logical port and real ports associated with two of said plurality of connection control nodes.
- 5 9. The interworking node of Claim 8, wherein said means for interworking further comprises: means for establishing a physical connection between said real ports of said two connection control nodes for a call connection.
10. A system for combining narrowband and broadband transport mechanisms in a communications network, comprising:
10 a plurality of call control nodes each including switching intelligence and narrowband switching fabric;
a plurality of connection control nodes each including broadband switching fabric; and
at least one intermediate node operatively connectable to said plurality of call control nodes
15 and said plurality of connection control nodes, said at least one intermediate node being adapted to interwork between said plurality of call control nodes and said plurality of connection control nodes, said at least one intermediate node being controlled by all of said plurality of call control nodes.
11. The system of Claim 10, wherein said plurality of connection control nodes comprise at least
20 part of a broadband network.
12. The system of Claim 10, wherein each said call control node of said plurality of call control nodes has an identity associated therewith, each said call control node of said plurality of call control nodes including said respective identity with each message transmitted to said intermediate node.
25
13. The system of Claim 12, wherein said intermediate node has a plurality of resources therein for interworking between said plurality of call control nodes and said plurality of connection control nodes, an assigned one of said plurality of resources having said identity of at least one of said call control nodes associated therewith.
30
14. The system of Claim 13, wherein said assigned resource comprises a logical port for supporting connections between two of said plurality of call control nodes, said logical port having

said identity of said two call control nodes associated therewith.

15. The system of Claim 14, wherein said logical port represents a logical E1 path between said two call control nodes.

5

16. The system of Claim 15, wherein said assigned resource further comprises a call handler within said intermediate node, said logical port being handled by said call handler.

17. The system of Claim 16, wherein said assigned resource further comprises a switch device within said intermediate node, said switch device being a logical device that corresponds to the logical E1 path between said two call control nodes.

10

18. The system of Claim 17, wherein said intermediate node further comprises a mapping function for mapping an address for said switch device to an address for said logical port.

15

19. The system of Claim 14, wherein said intermediate node is further adapted to establish logical paths between said logical port and real ports associated with two of said plurality of connection control nodes.

20. The system of Claim 19, wherein said intermediate node is further adapted to establish a physical connection between said real ports of said two connection control nodes for a call connection.

20

21. A method for combining narrowband and broadband transport mechanisms in a communications network, comprising the steps of:

25 providing a plurality of call control nodes each including switching intelligence and narrowband switching fabric;

providing a plurality of connection control nodes each including broadband switching fabric;

and

30 interworking between said plurality of call control nodes and said plurality of connection control nodes using at least one intermediate node, said at least one intermediate node being controlled by all of said plurality of call control nodes.

22. The method of Claim 21, wherein each said call control node of said plurality of call control nodes has an identity associated therewith, and further comprising the step of:
transmitting a message from a sending one of said plurality of call control nodes, said message including said identity of said sending call control node.
- 5
23. The method of Claim 22, wherein said intermediate node has a plurality of resources therein for interworking between said plurality of call control nodes and said plurality of connection control nodes, and further comprising the step of:
assigning said identity of at least one of said plurality of call control nodes to an assigned one
10 of said plurality of resources.
24. The method of Claim 23, wherein said assigned resource comprises a logical port for supporting connections between two of said plurality of call control nodes, and wherein said step of assigning further comprises the step of:
15 assigning said identity of said two call control nodes to said logical port.
25. The method of Claim 24, wherein said assigned resource further comprises a call handler within said intermediate node, and further comprising the step of:
handling said logical port by said call handler.
- 20
26. The method of Claim 25, wherein said assigned resource further comprises a switch device within said intermediate node corresponding to a logical E1 path between said two call control nodes, and further comprising the step of:
mapping between an address for said switch device and an address for said logical port.
- 25
27. The method of Claim 24, further comprising the step of:
establishing logical paths between said logical port and real ports associated with two of said plurality of connection control nodes.
- 30
28. The system of Claim 27, further comprising the step of:
establishing a physical connection between said real ports of said two connection control nodes for a call connection.

-55-

29. A method for supporting control of at least one intermediate node by a plurality of call control nodes in a communications network, said plurality of call control nodes each including switching intelligence and narrowband switching fabric, said intermediate node interworking between said plurality of call control nodes and a plurality of connection control nodes each having broadband switching fabric, said method comprising the steps of:
- 5 providing each said call control node of said plurality of call control nodes with an identity; and
- assigning said identity of at least one of said plurality of call control nodes to an assigned one of a plurality of resources within said intermediate node, said plurality of resources for interworking
- 10 between said plurality of call control nodes and said plurality of connection control nodes.
30. The method of Claim 29, further comprising the step of:
- transmitting a message from a sending one of said plurality of call control nodes, said message including said identity of said sending call control node.
- 15
31. The method of Claim 29, wherein said assigned resource comprises a logical port for supporting connections between two of said plurality of call control nodes, and wherein said step of assigning further comprises the step of:
- assigning said identity of said two call control nodes to said logical port.
- 20
32. A method for establishing a call connection between two call control nodes controlling an intermediate node, said two call control nodes each including switching intelligence and narrowband switching fabric, said call connection being established through a broadband network via at least one connection control node having broadband switching fabric, said method comprising the steps of:
- 25 assigning a logical port within said intermediate node to said two call control nodes, said logical port for interworking between said two call control nodes and said at least one connection control nodes;
- establishing logical paths between said logical port and real ports associated with said at least one connection control node; and
- 30 establishing a physical connection between said real ports of said at least one connection control node for a call connection.

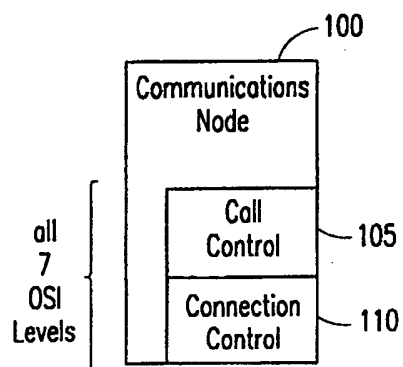

FIG. 1A
(PRIOR ART)

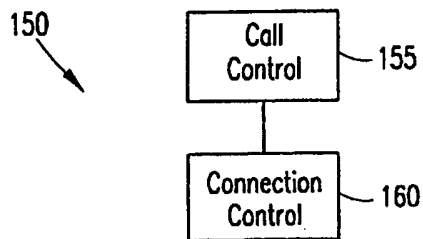

FIG. 1B
(PRIOR ART)

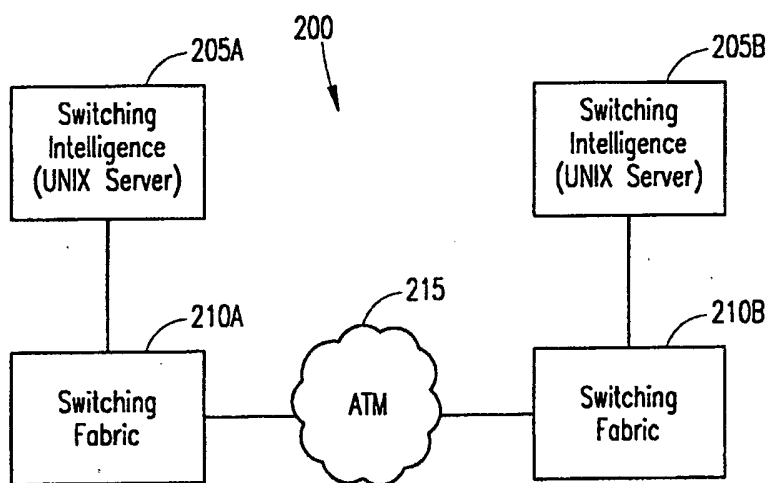
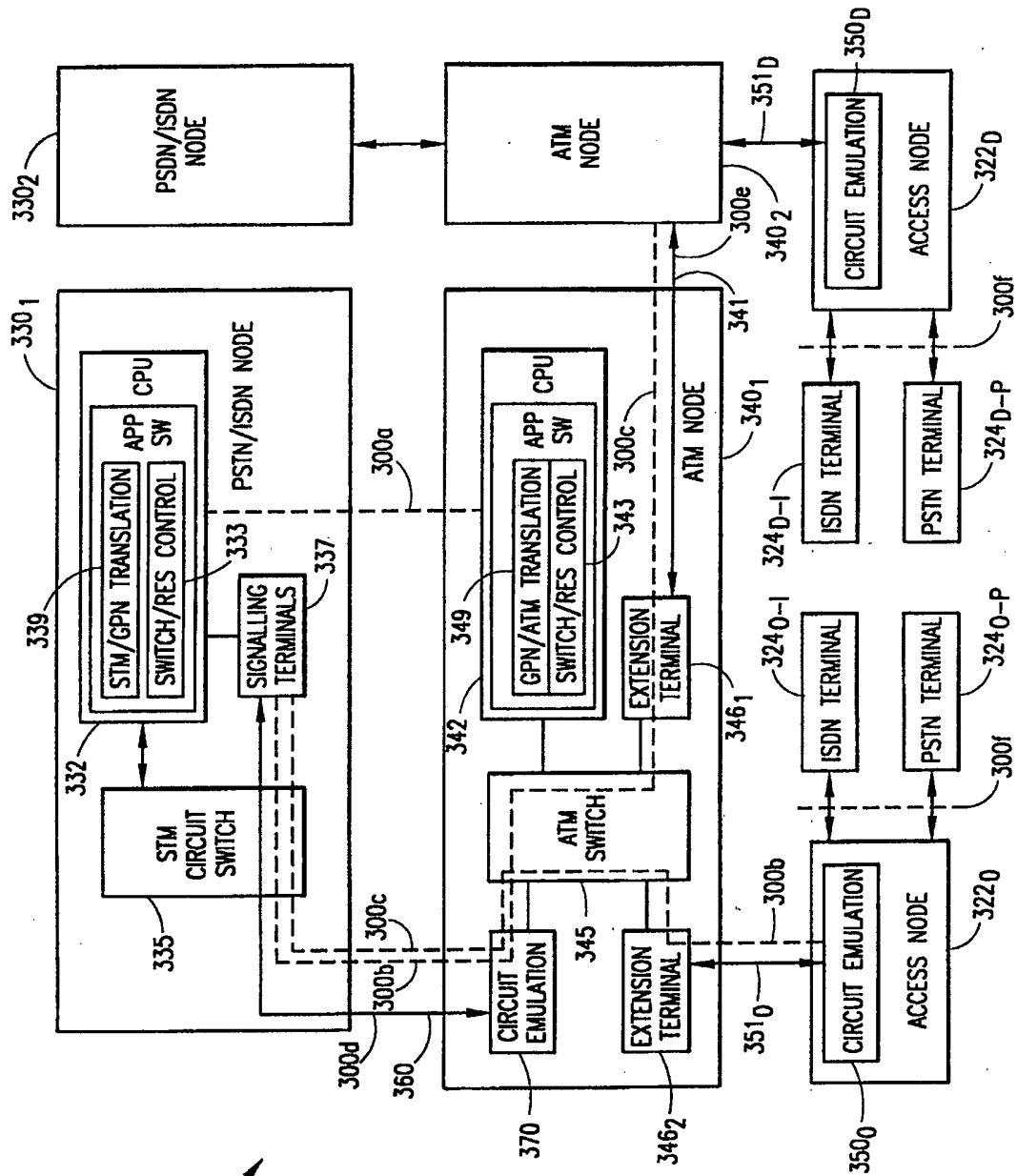

FIG. 2
(PRIOR ART)



320

FIG. 3

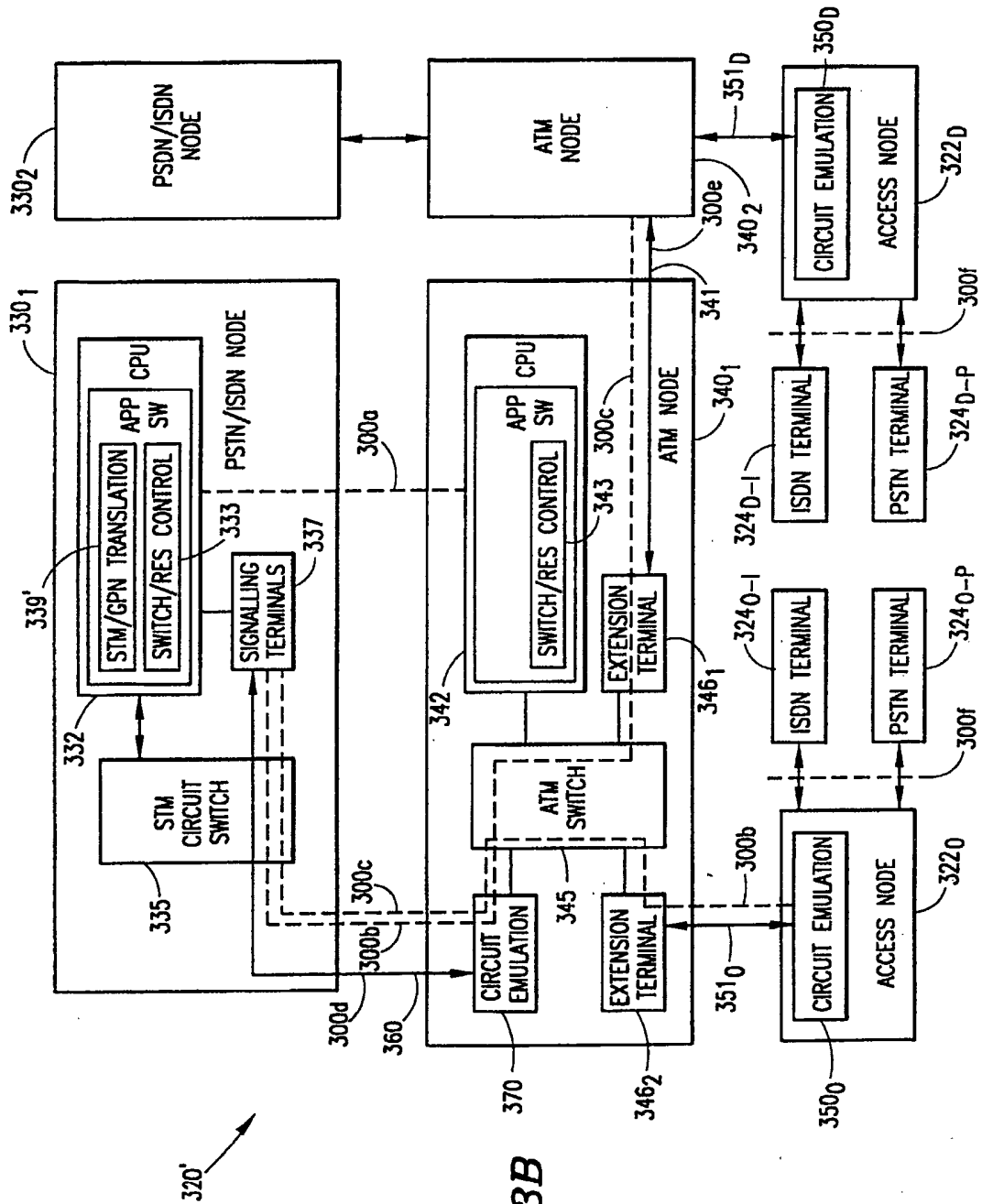

FIG. 3B

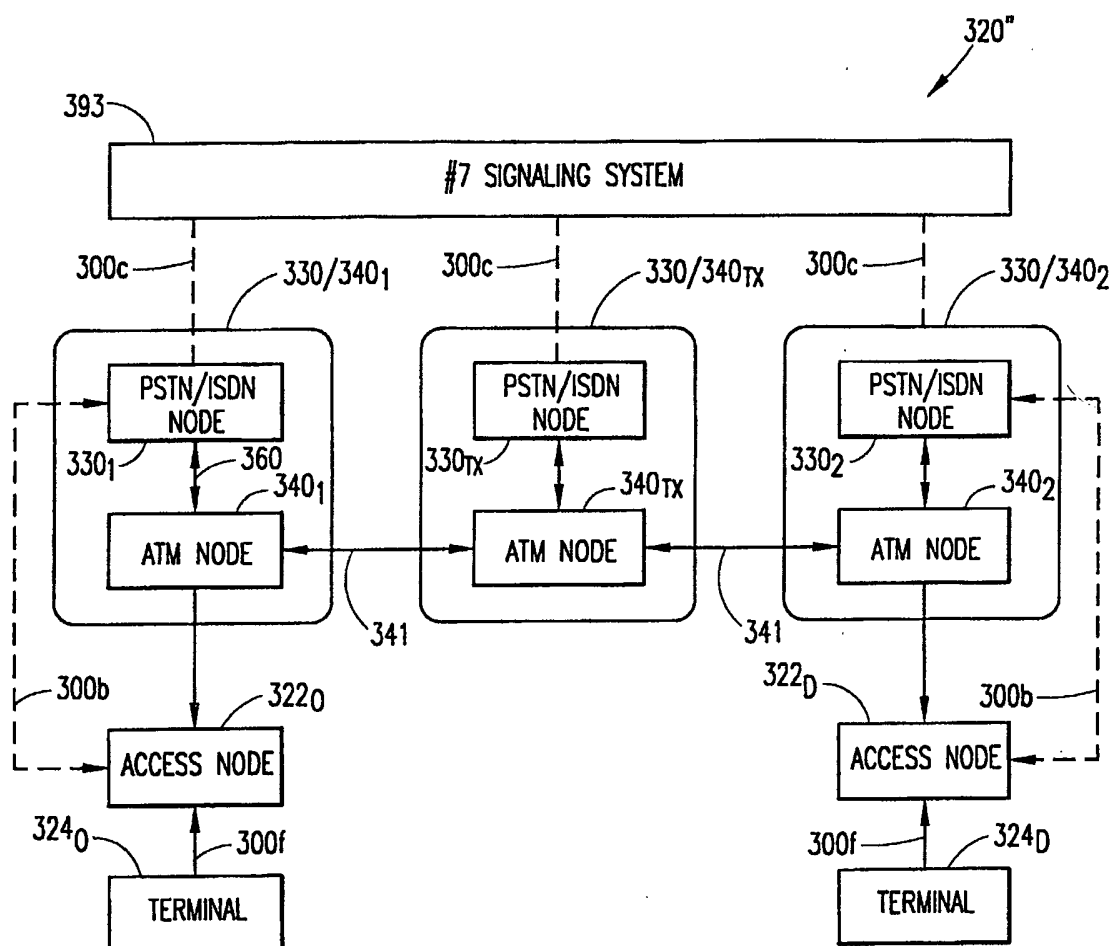

FIG. 3C

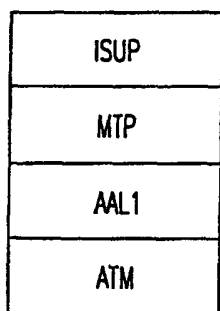

FIG. 3D

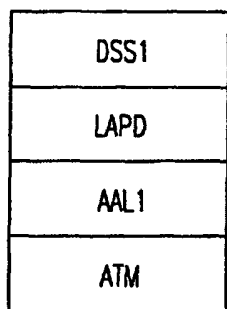

FIG. 3E

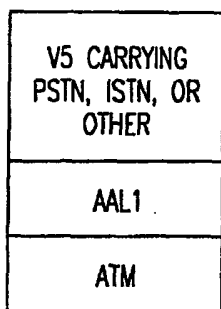

FIG. 3F

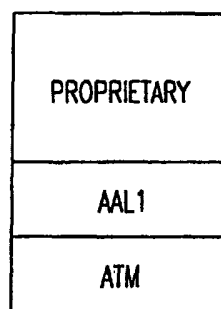

FIG. 3G

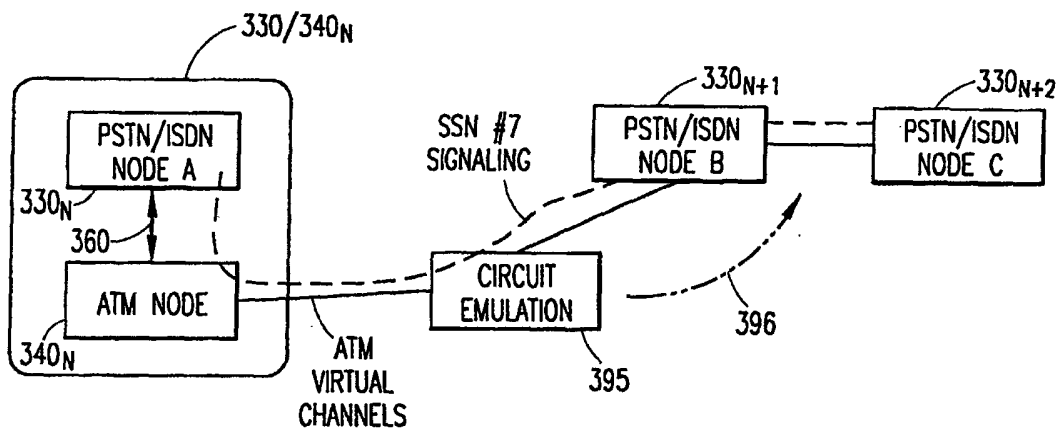

FIG. 3H

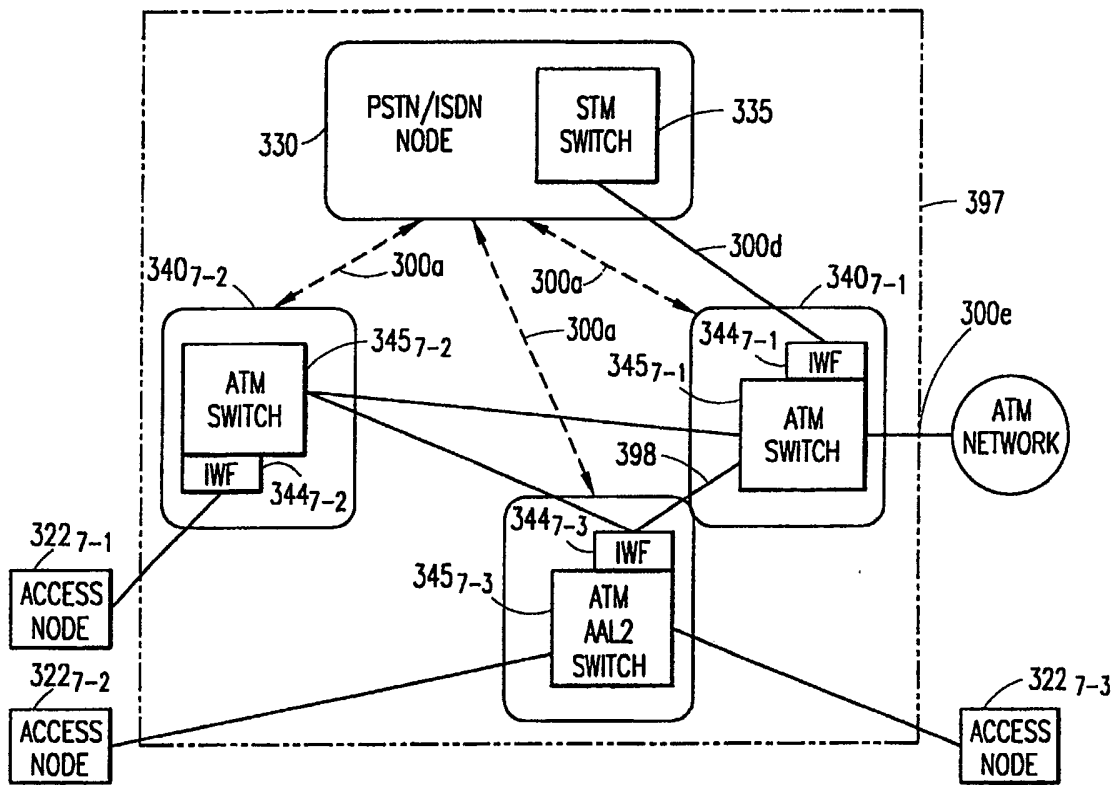

FIG. 31

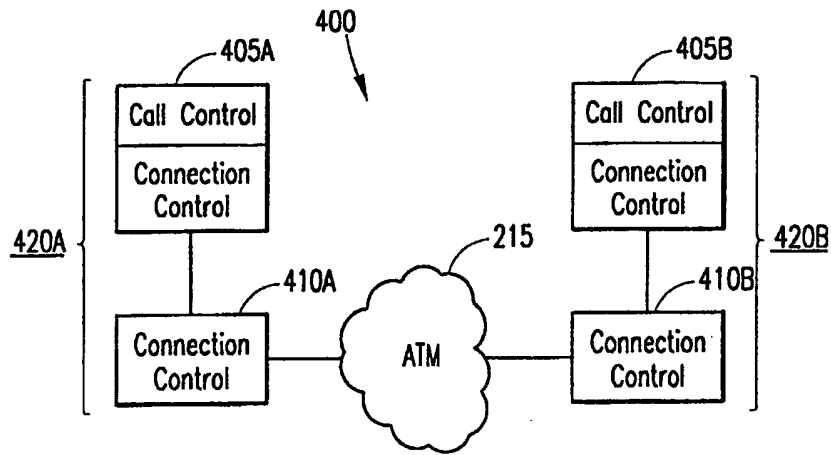

FIG. 4

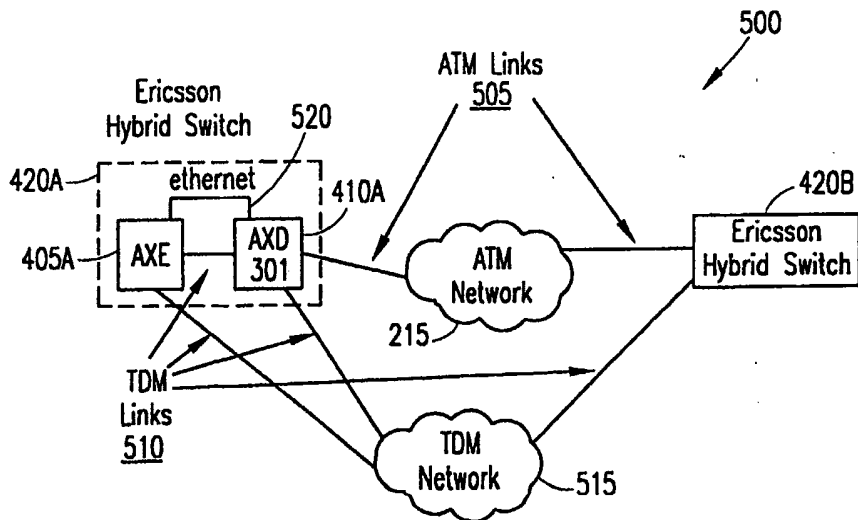

FIG. 5

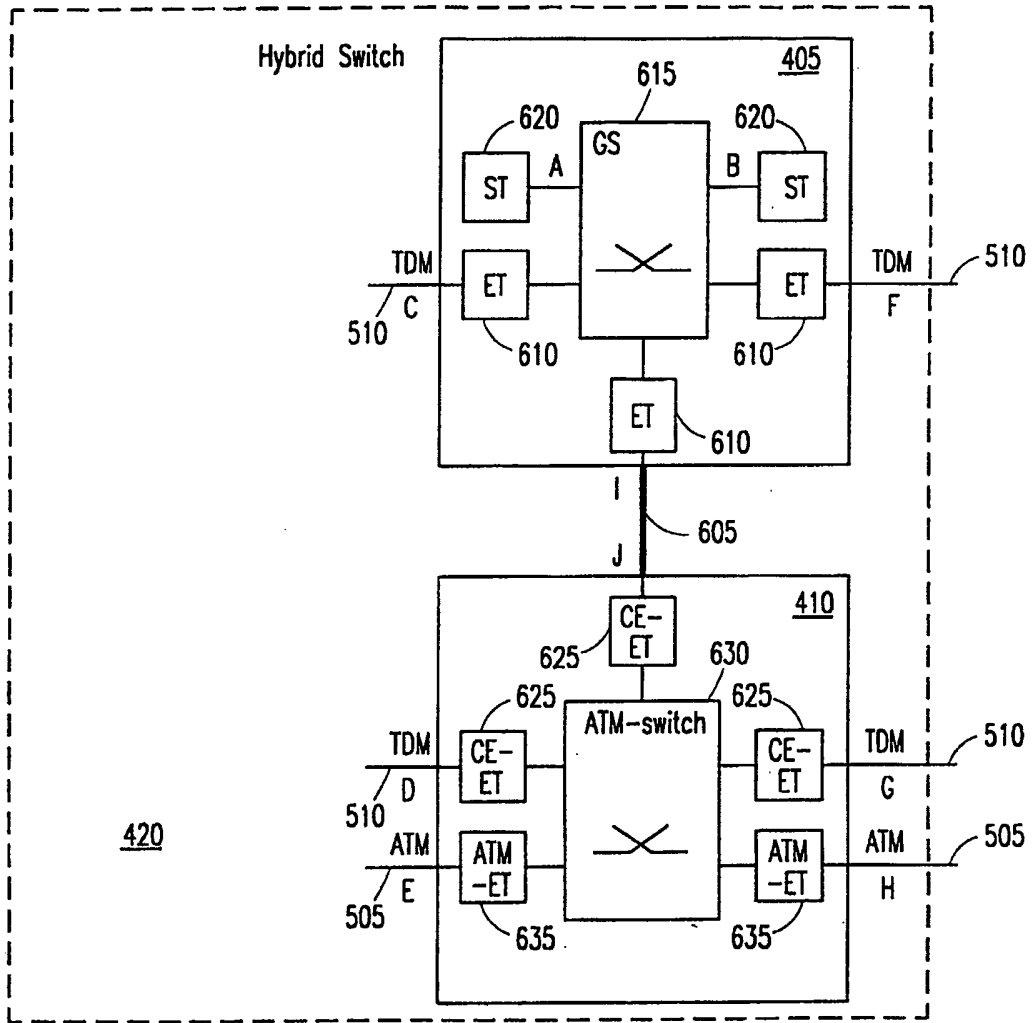

FIG. 6

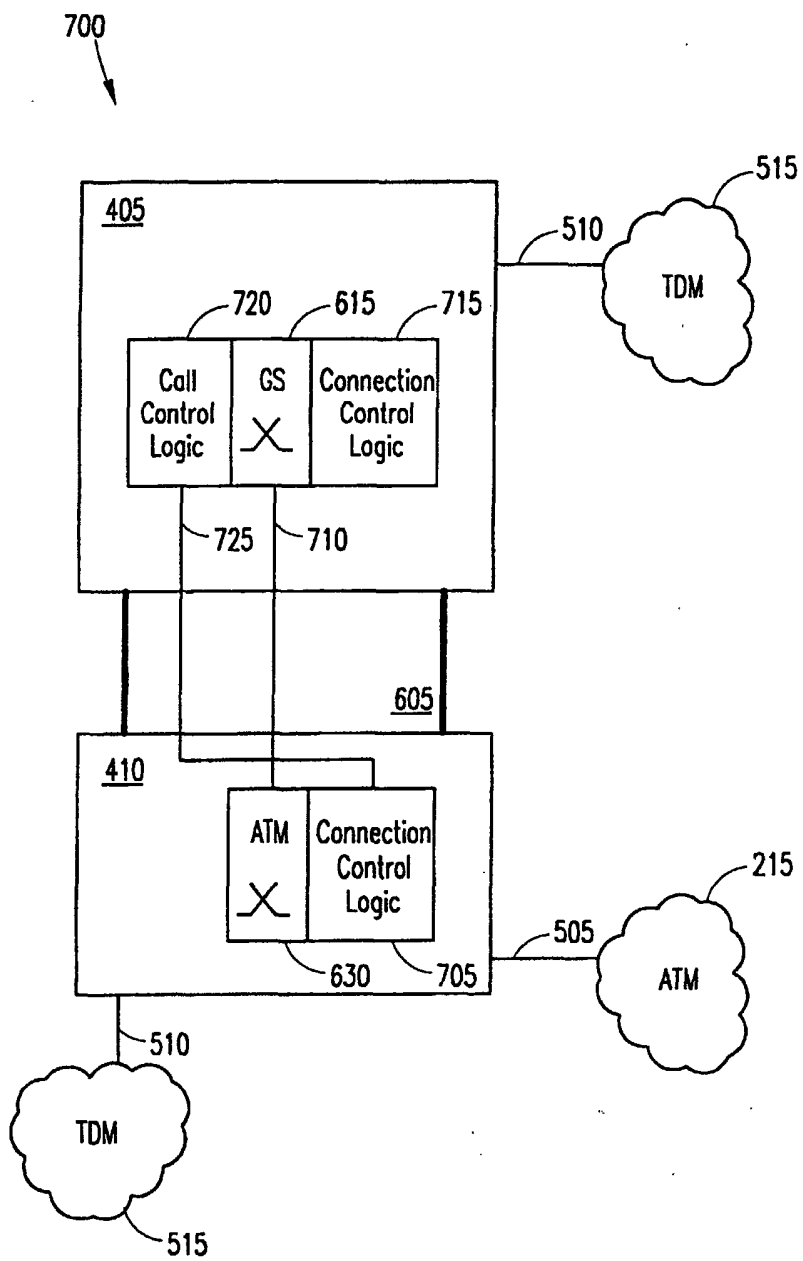

FIG. 7

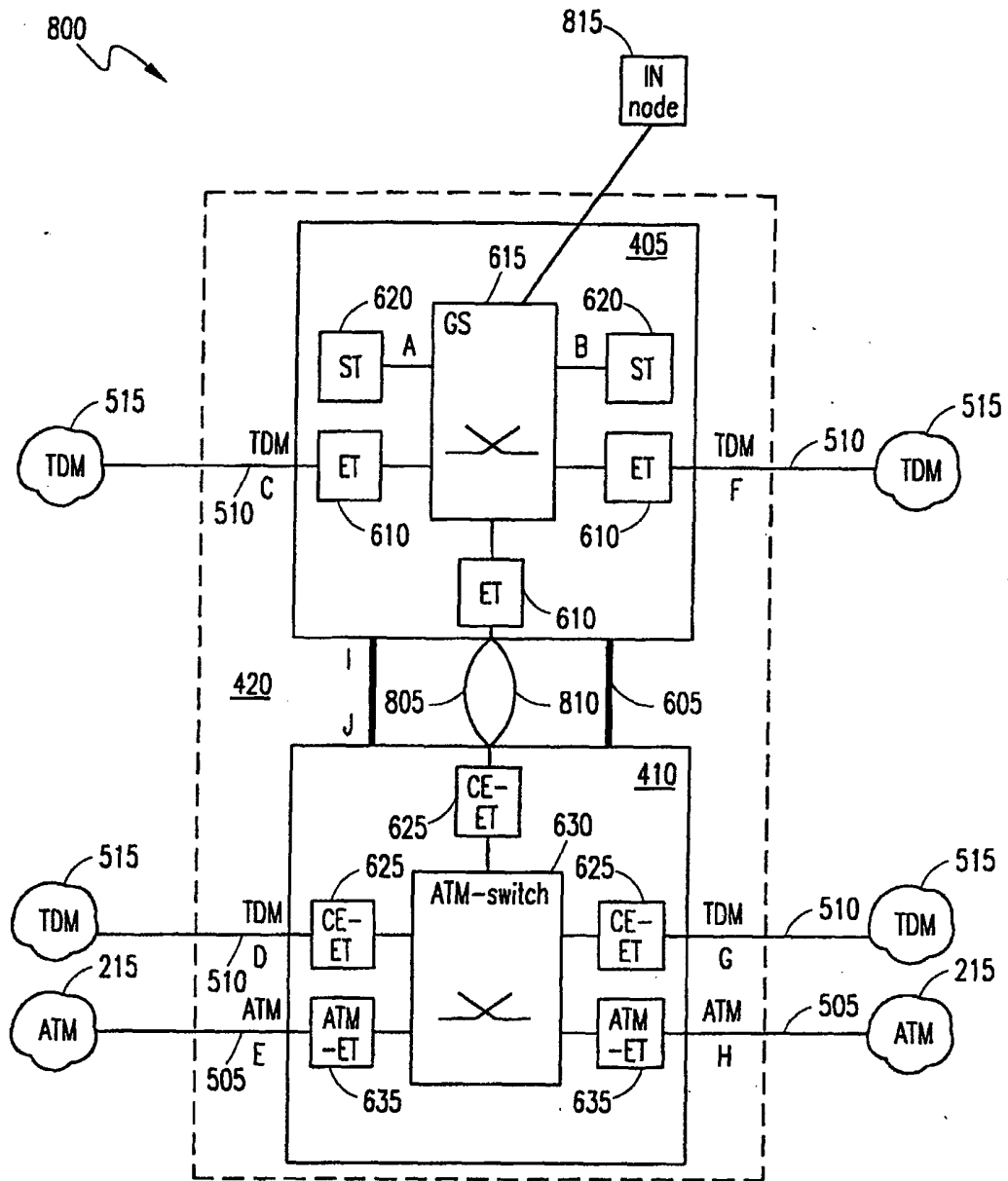

FIG. 8

900 ↘

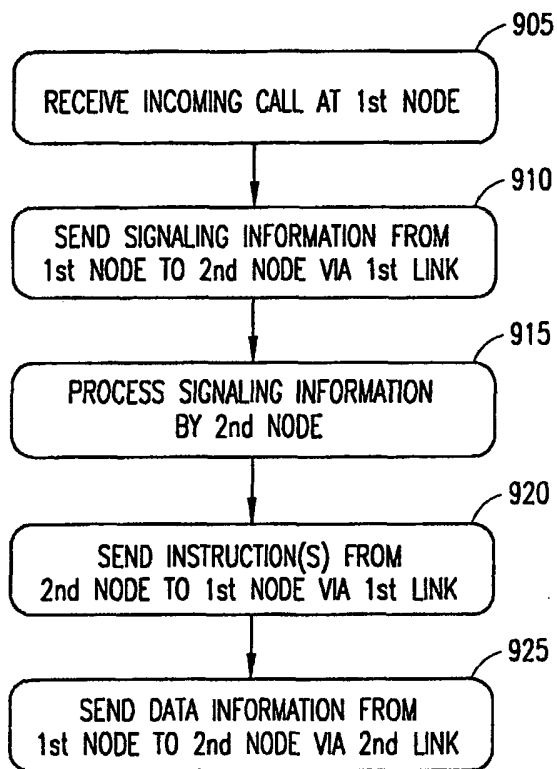

FIG. 9

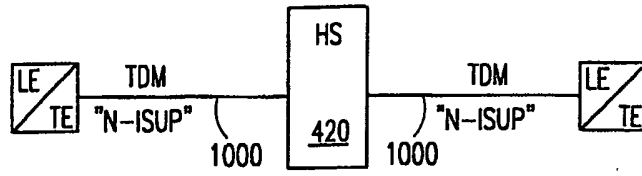

FIG. 10A

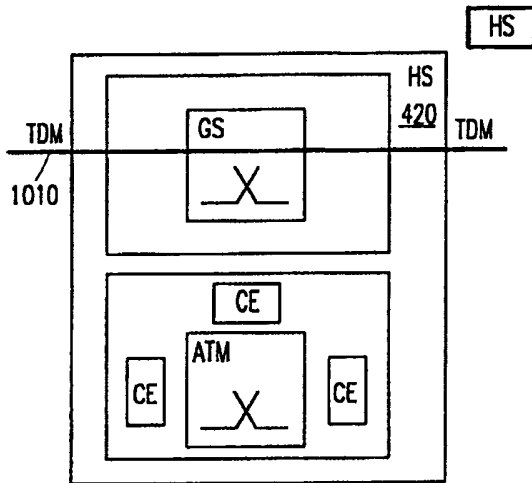

FIG. 10B

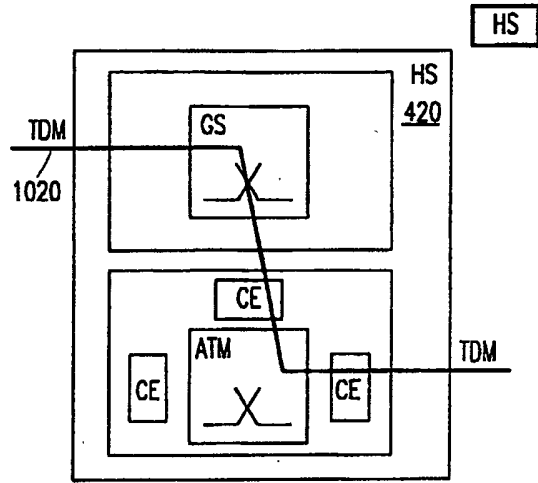

FIG. 10C

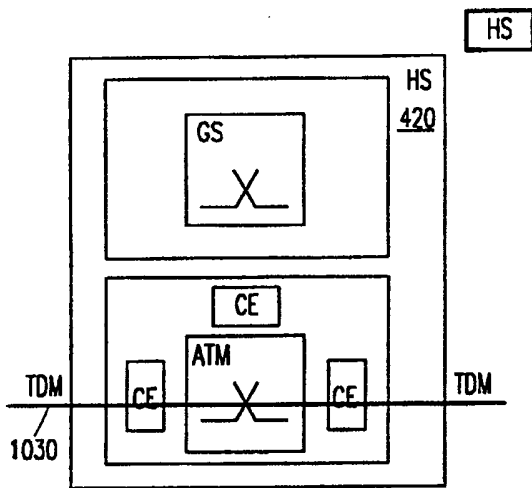

FIG. 10D

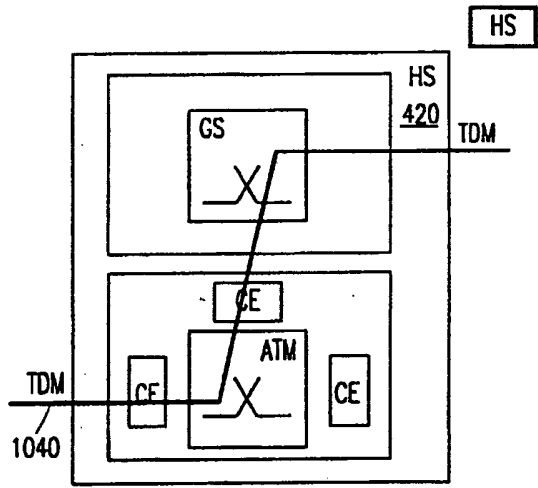

FIG. 10E

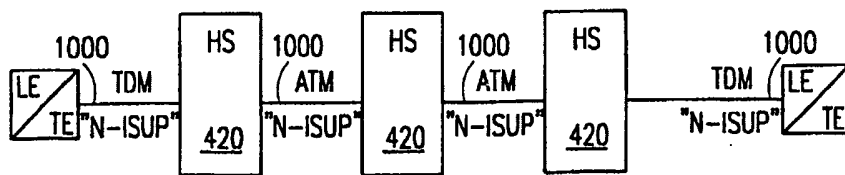

FIG. 10F

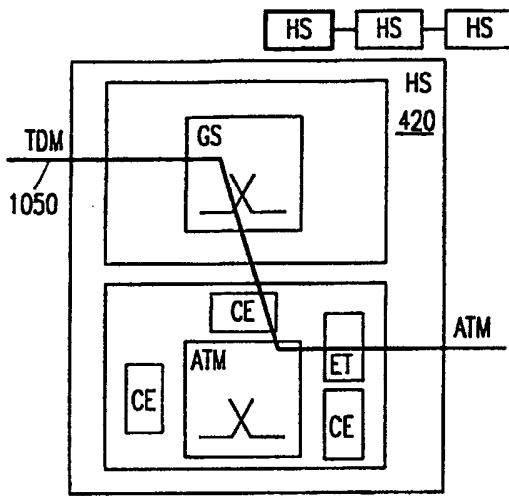

FIG. 10G

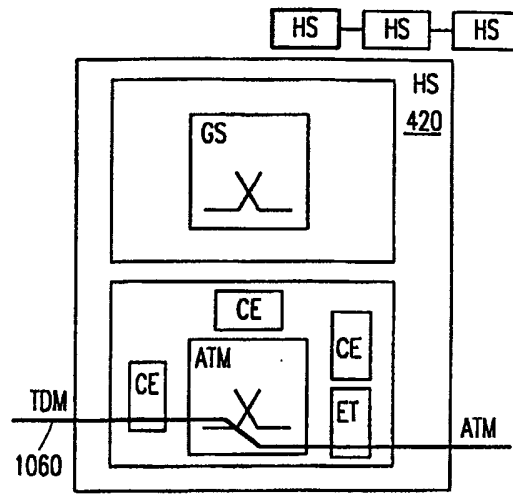

FIG. 10H

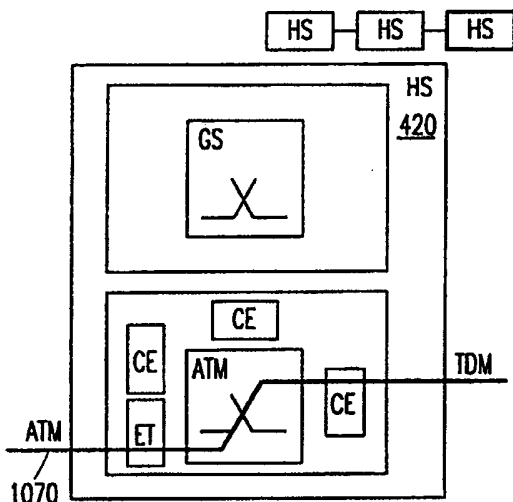

FIG. 10I

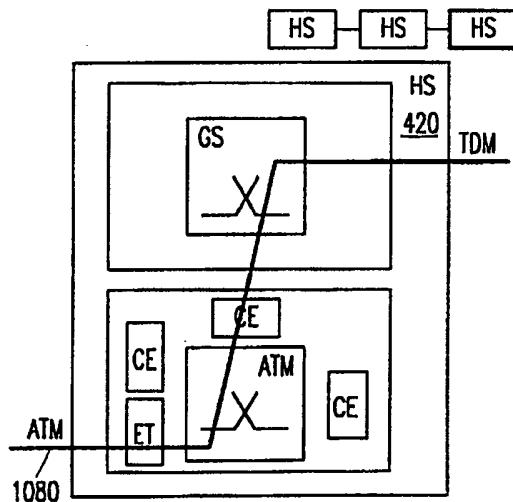

FIG. 10J

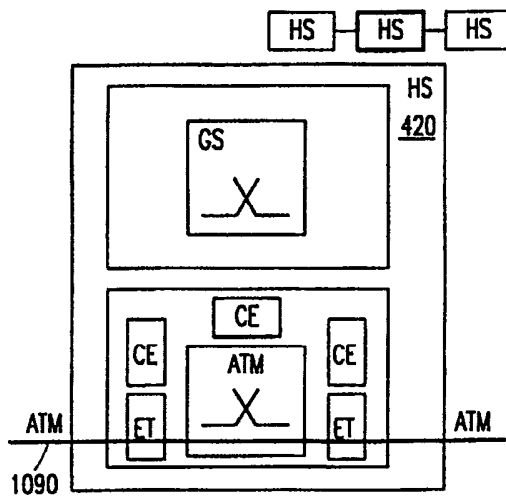

FIG. 10K

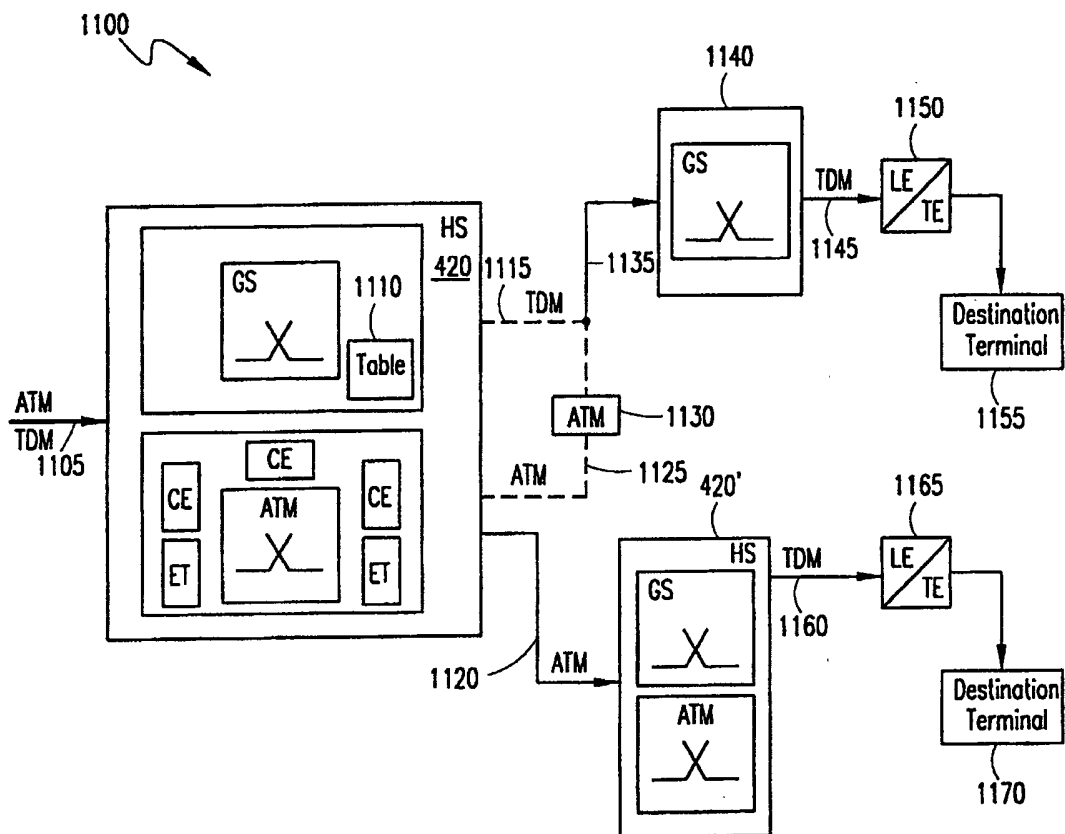

FIG. 11

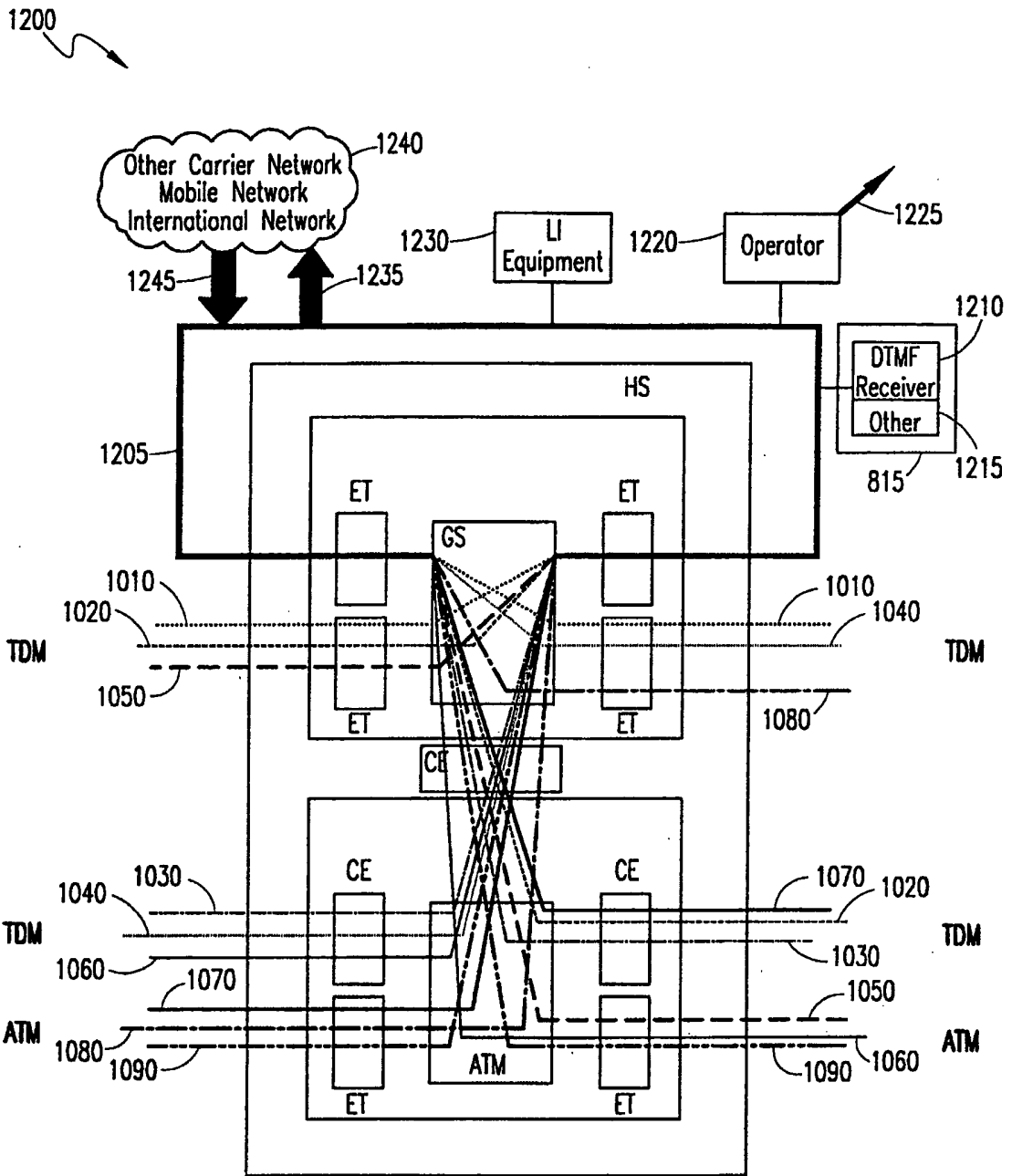

FIG. 12

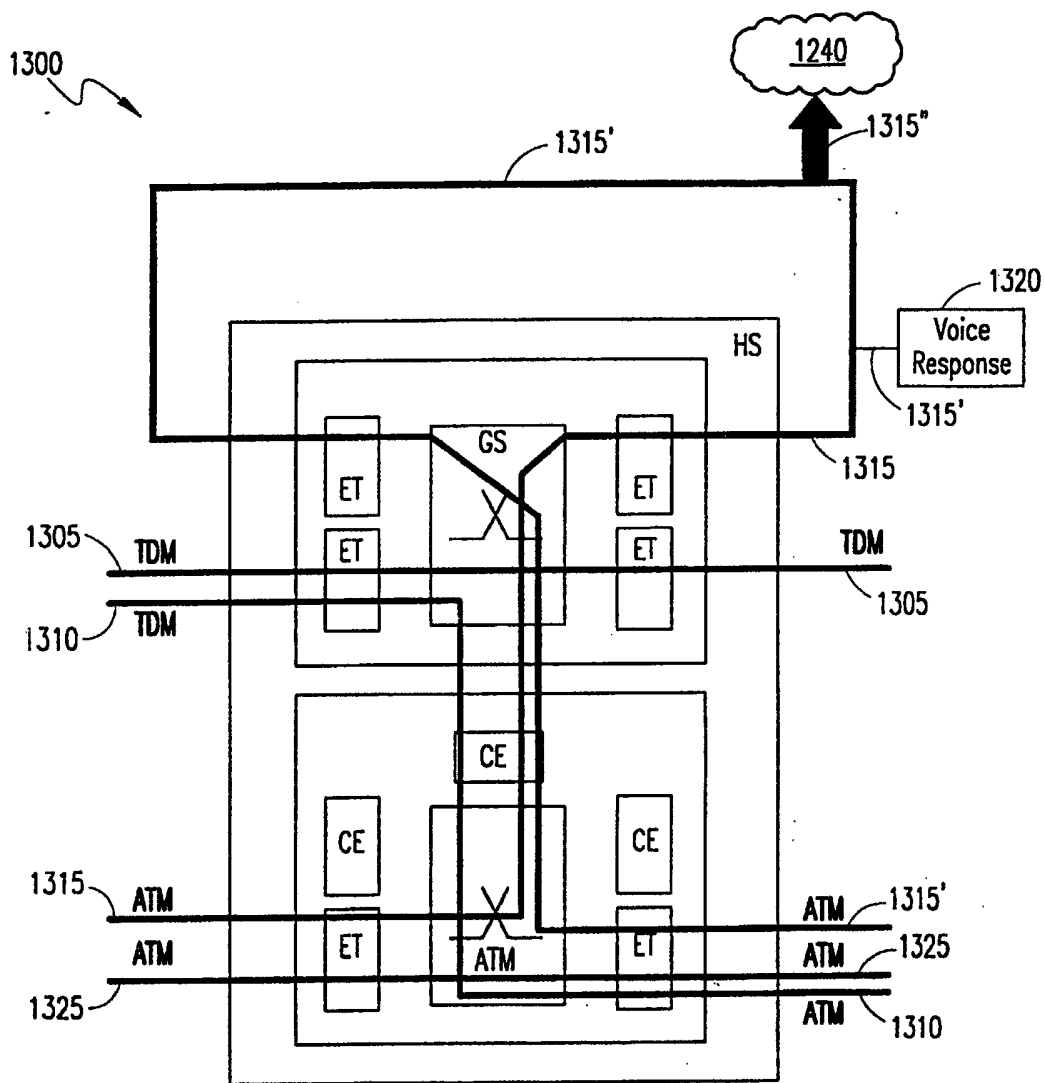

FIG. 13

1400 ↘

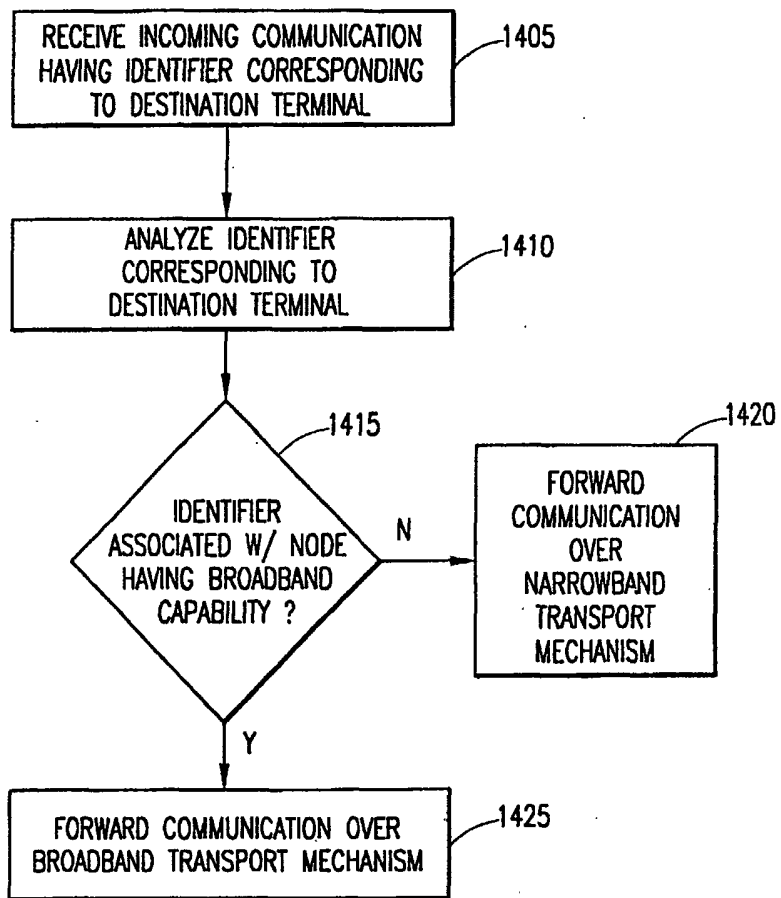

FIG. 14

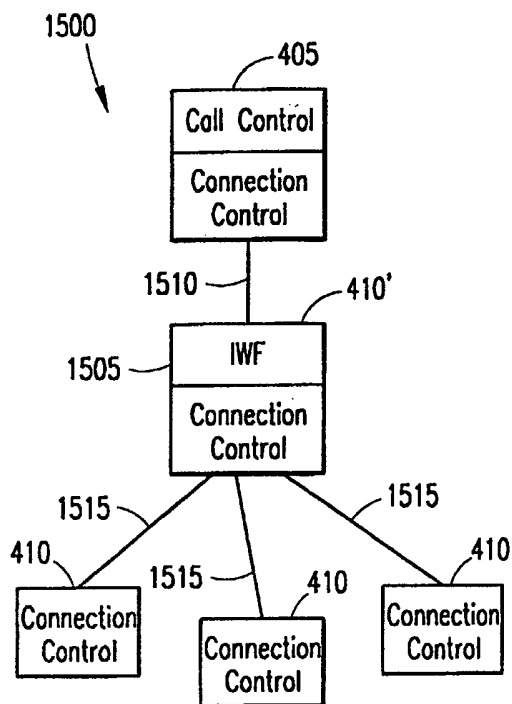

FIG. 15

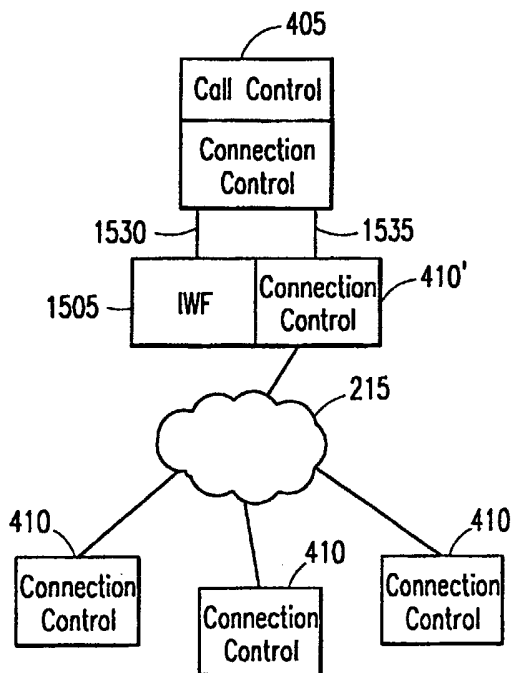

FIG. 15A

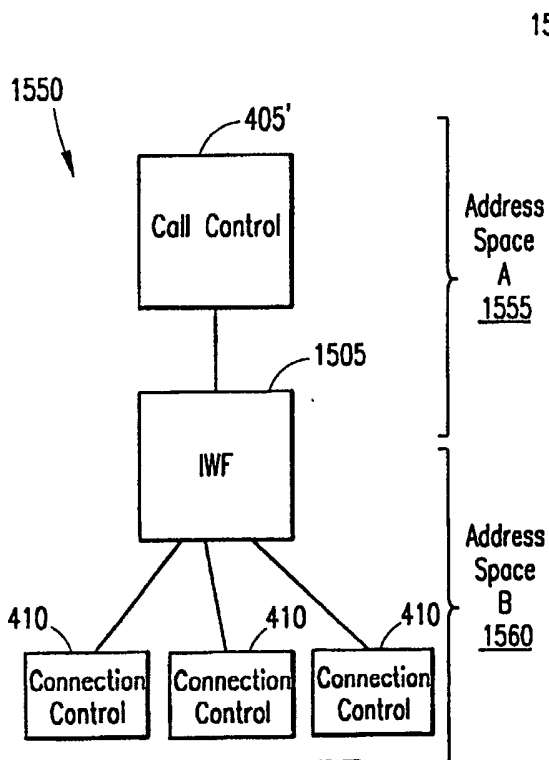

FIG. 15B

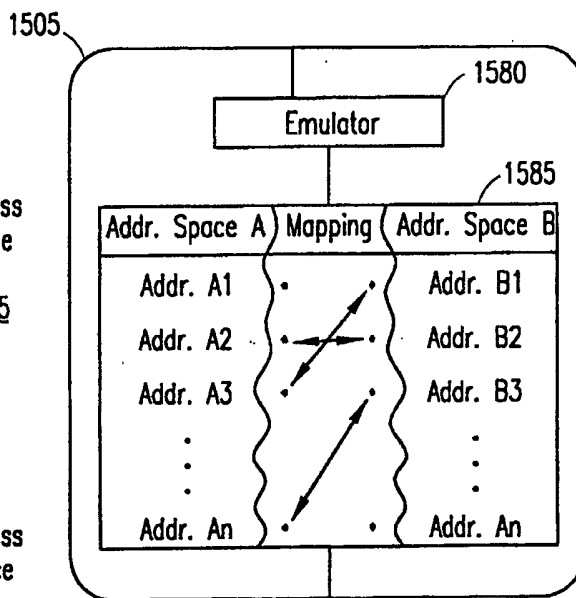

FIG. 15C

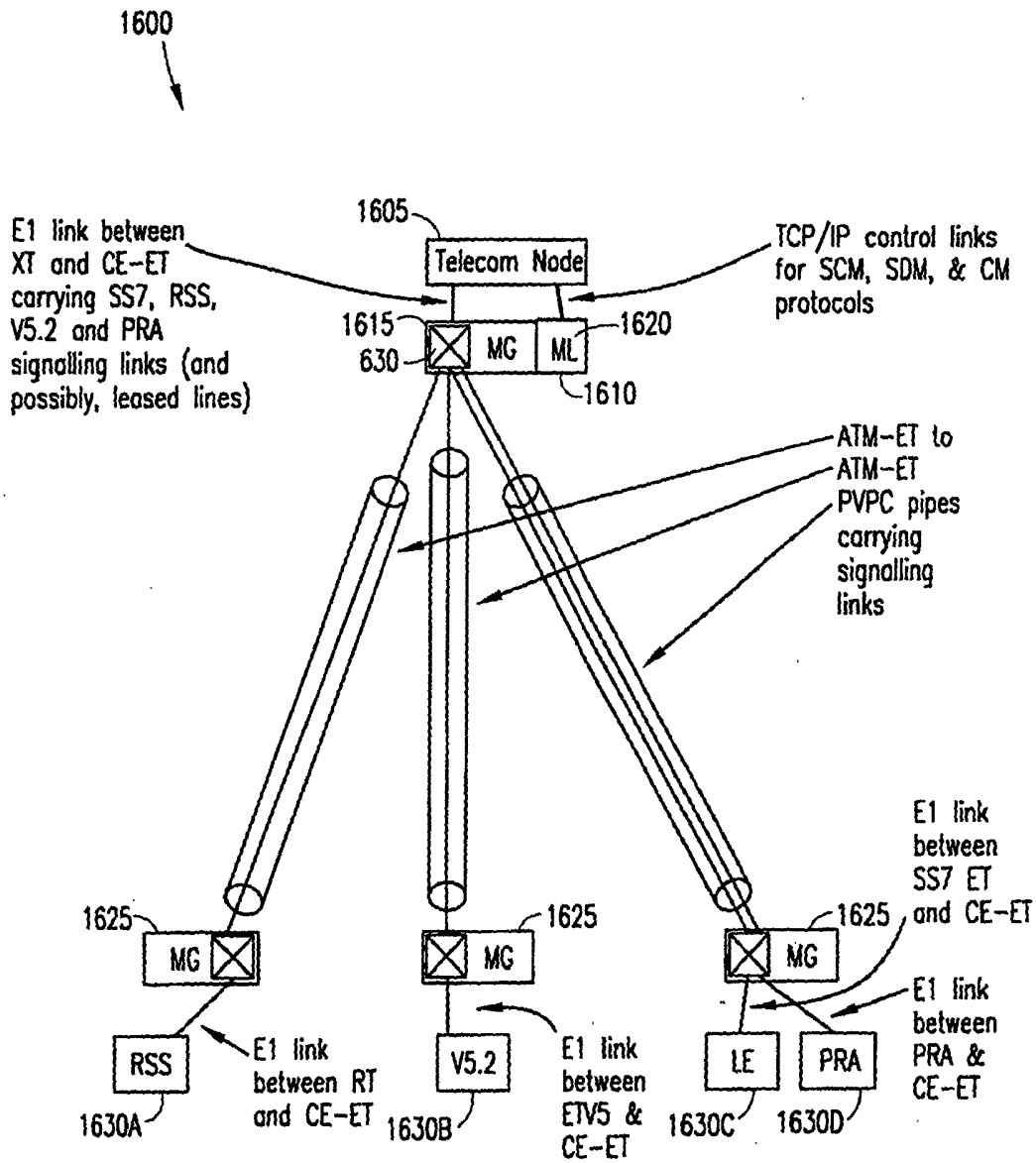
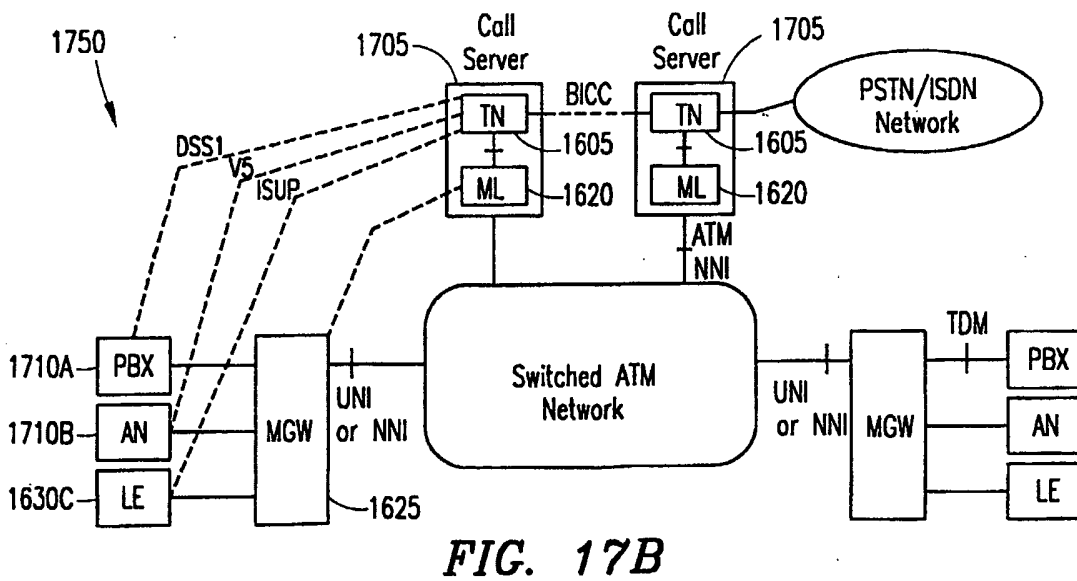
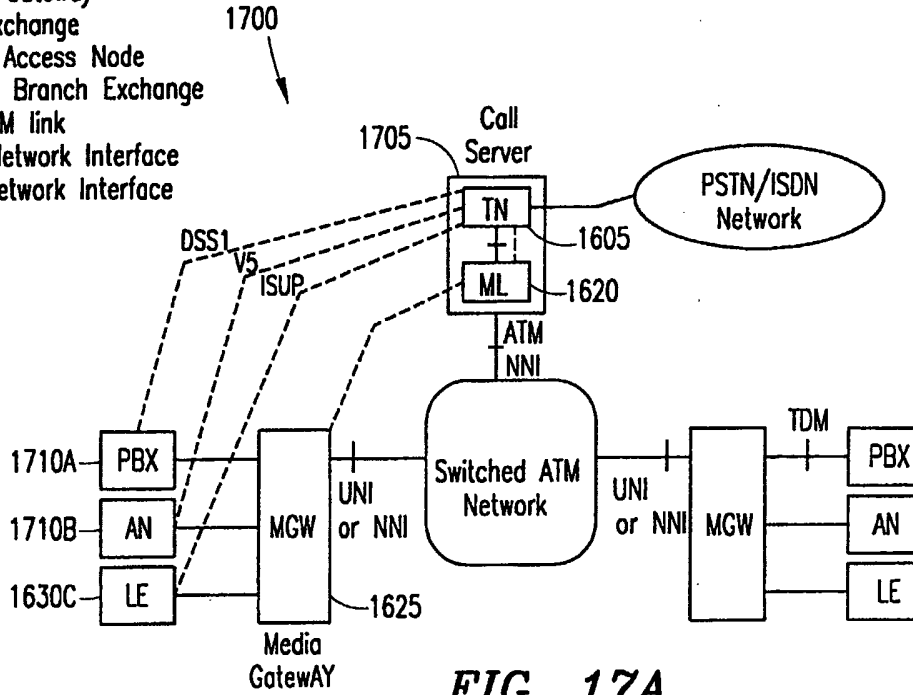

FIG. 16

ML—Media Logic
MGW—Media Gateway
LE—Local Exchange
AN—Generic Access Node
PBX—Private Branch Exchange
TDM—2M PCM link
NNI—Node Network Interface
UNI—User Network Interface



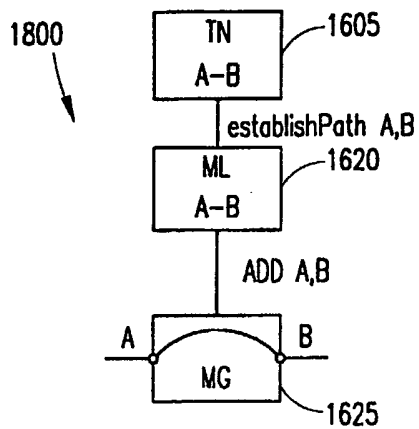

FIG. 18A

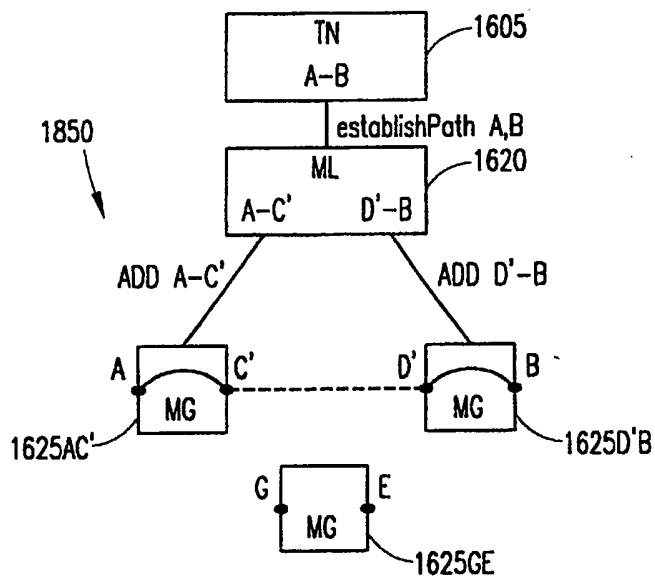
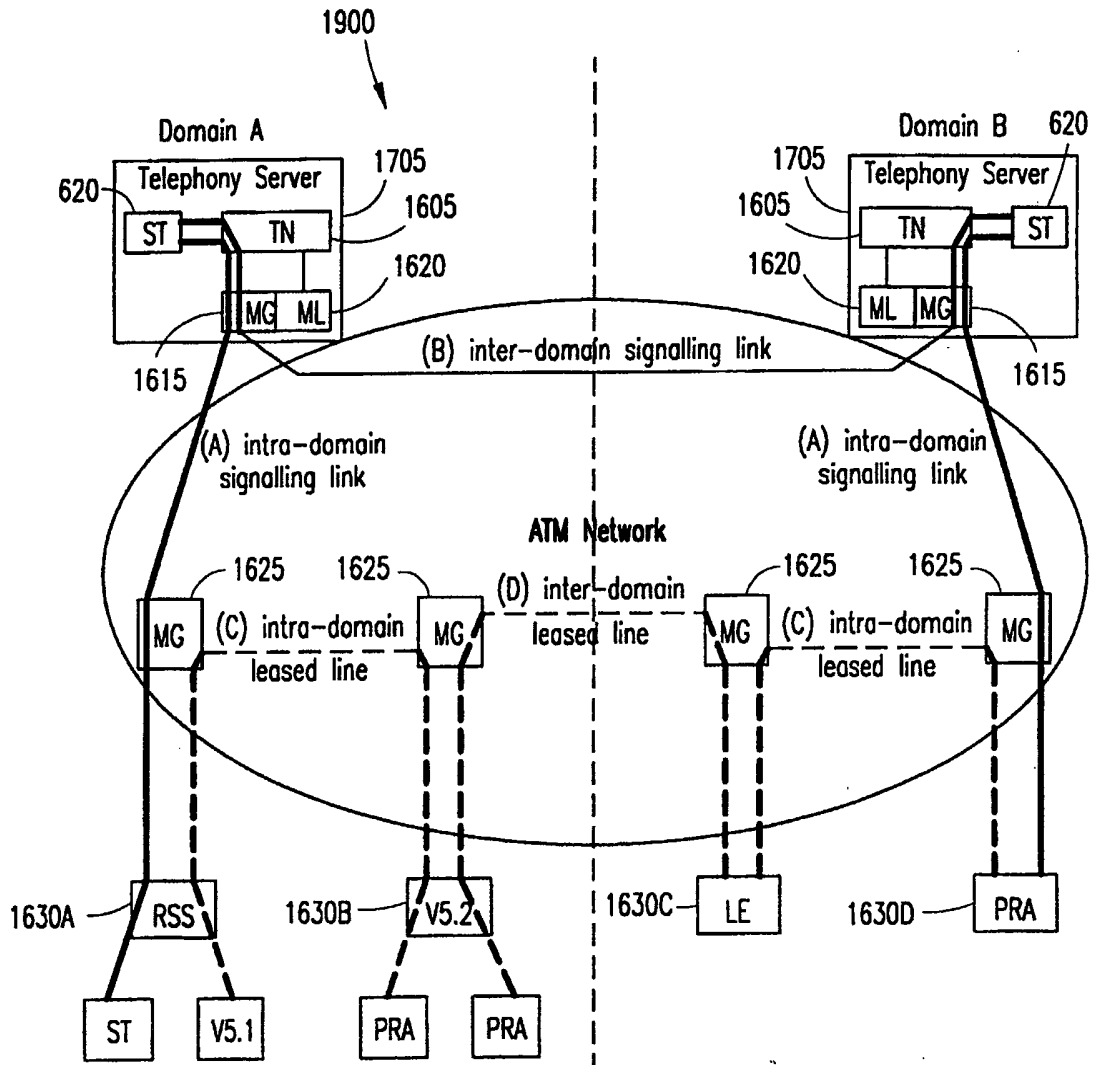

FIG. 18B



- The part of a signalling link configured by TN commands (A)
- The part of a signalling link configured by ATM Management System (B)
- - - The part of a signalling line configured by TN commands
- - - The part of a leased line configured by ATM Management System (C) & (D)

FIG. 19

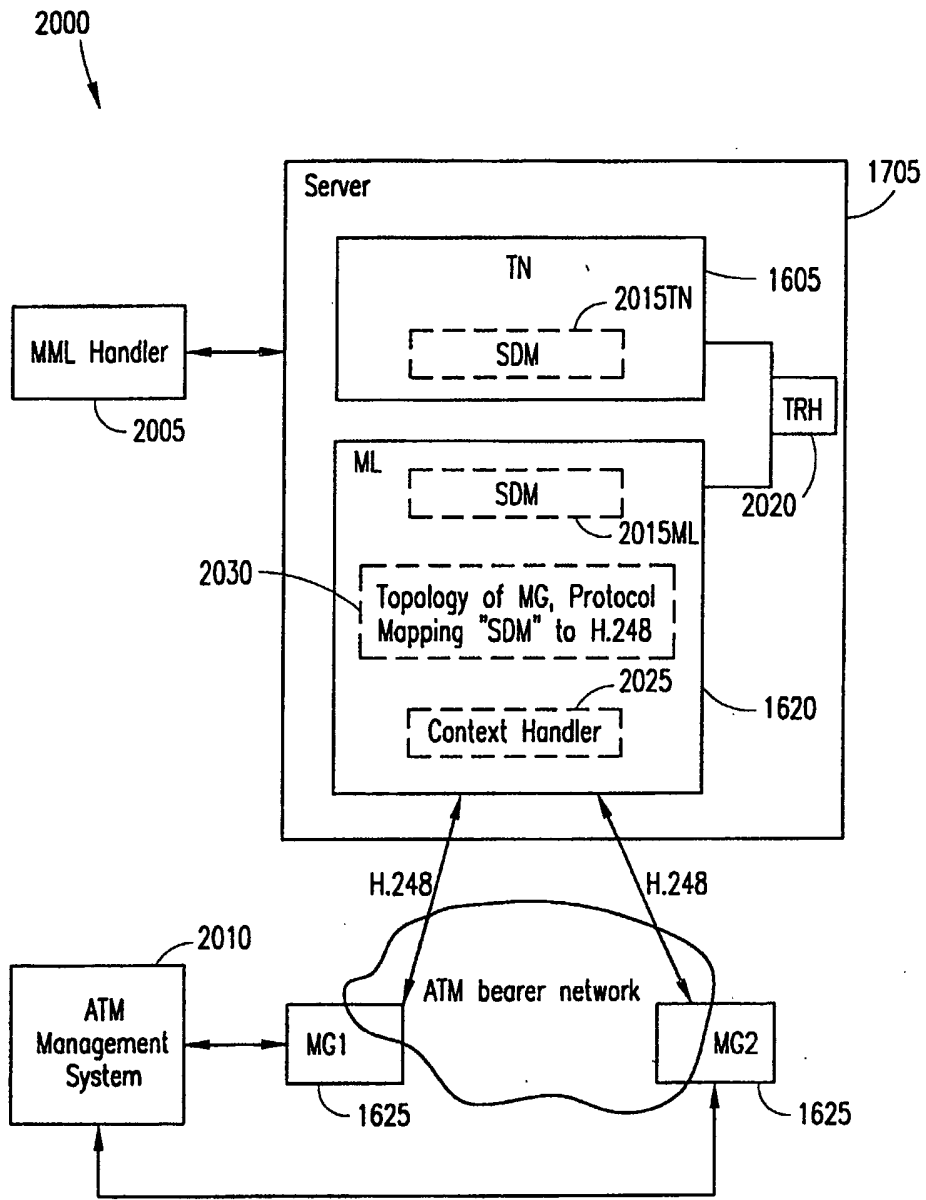

FIG. 20A

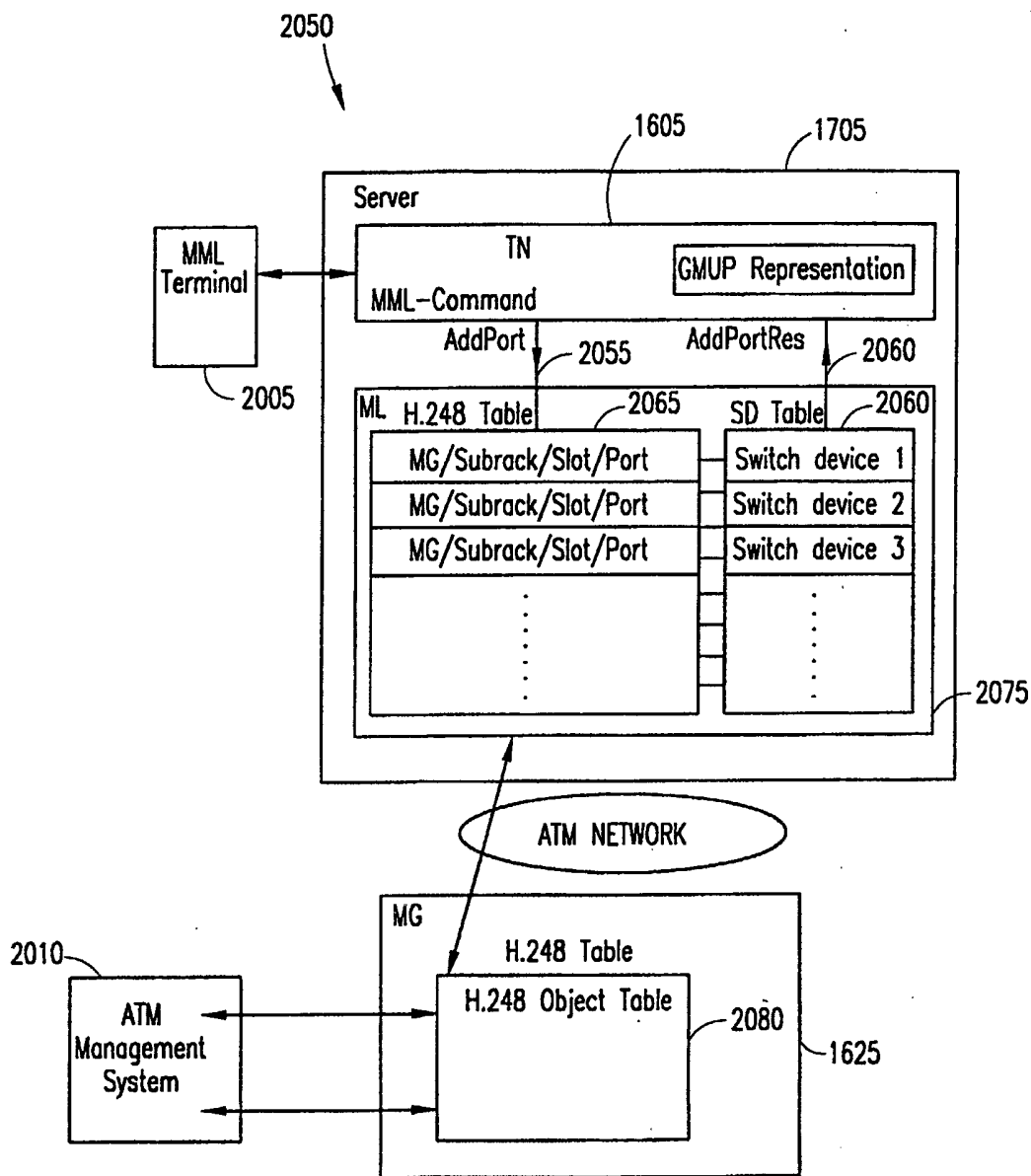

FIG. 20B

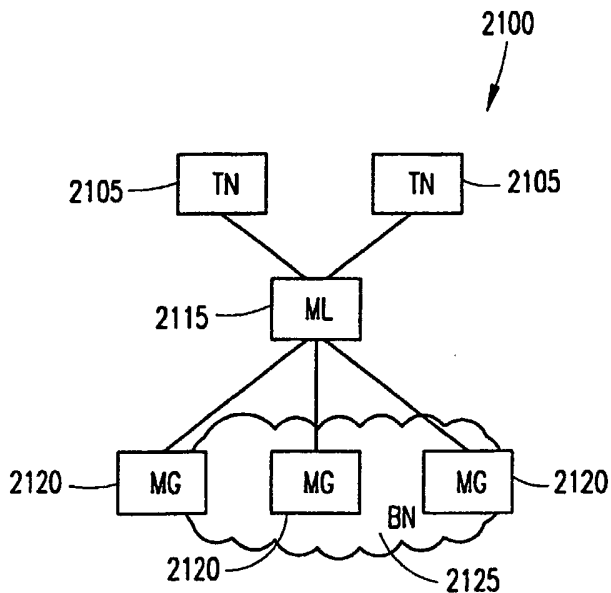

FIG. 21

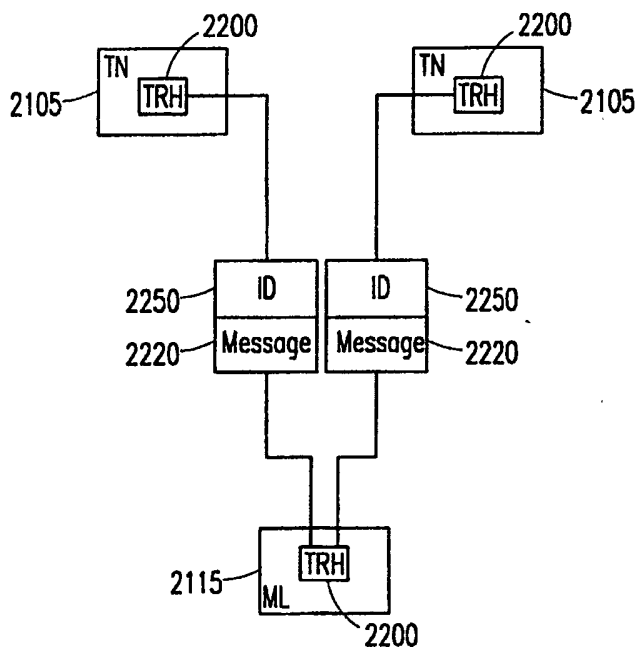

FIG. 22

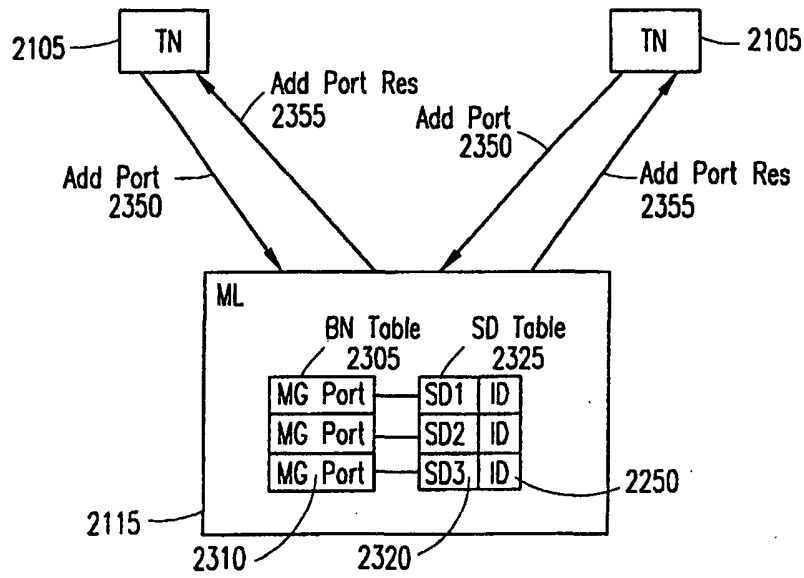

FIG. 23A

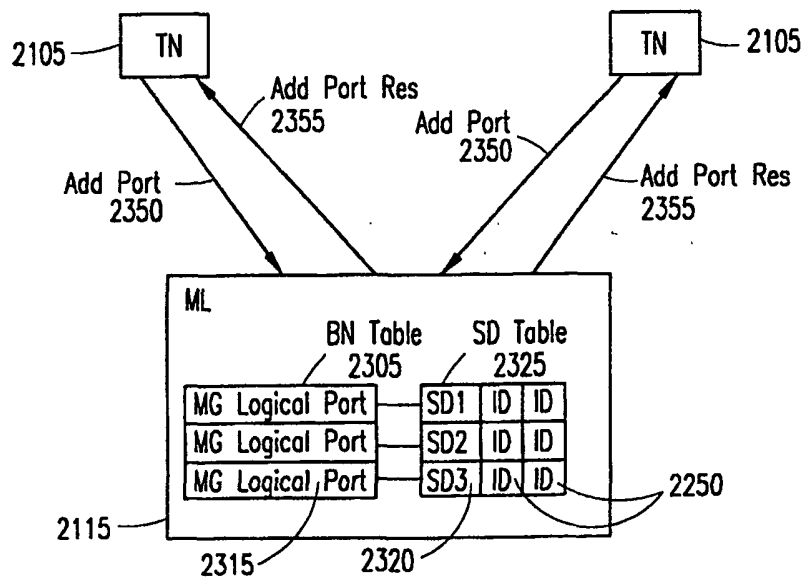

FIG. 23B

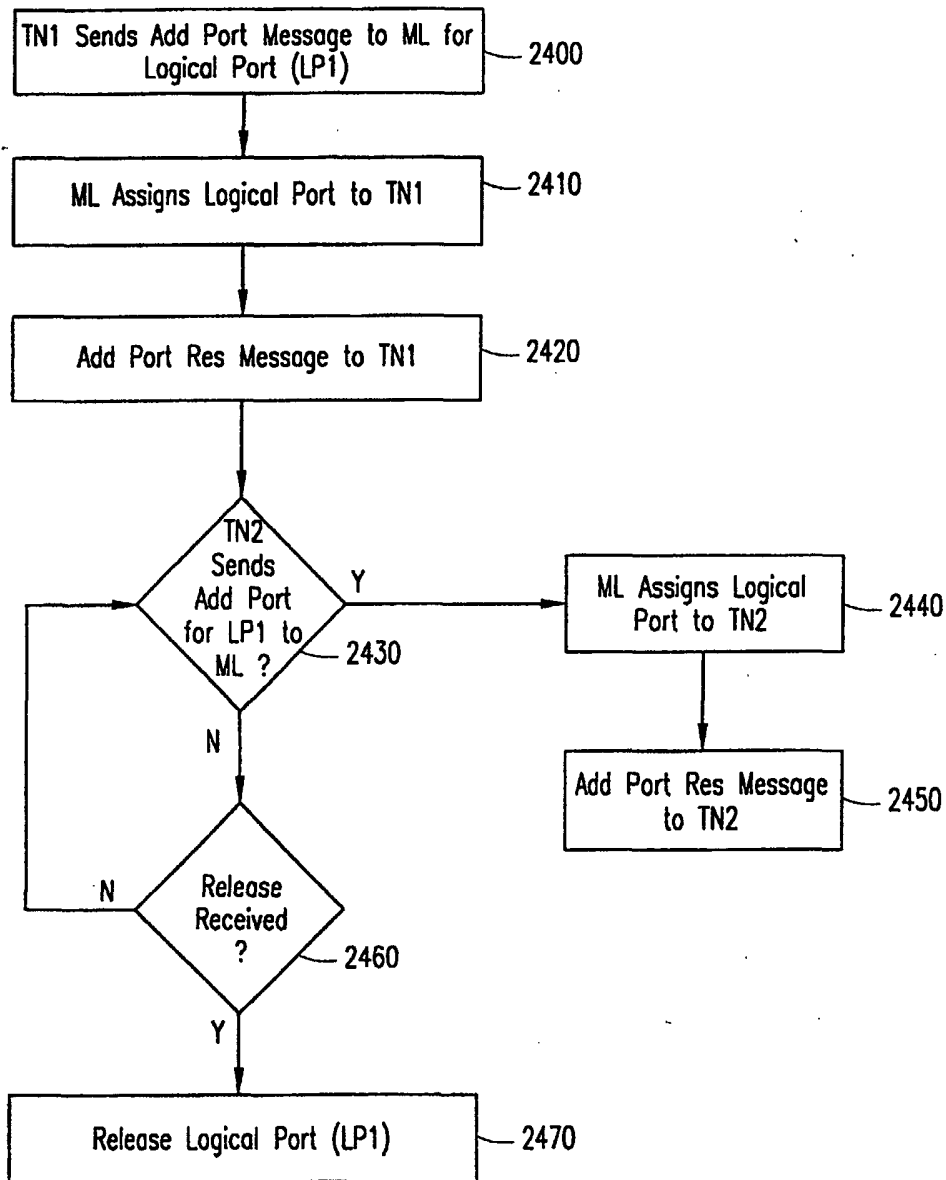

FIG. 24

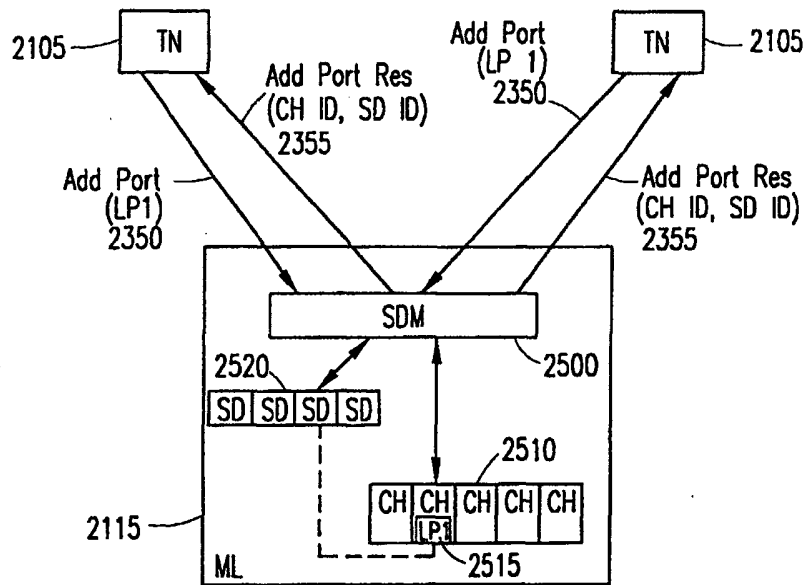

FIG. 25

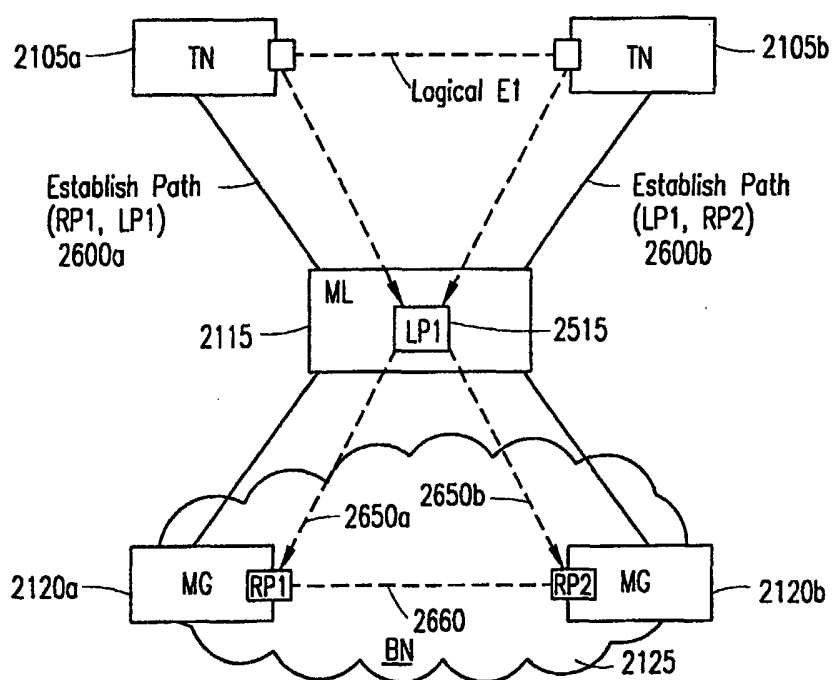

FIG. 26

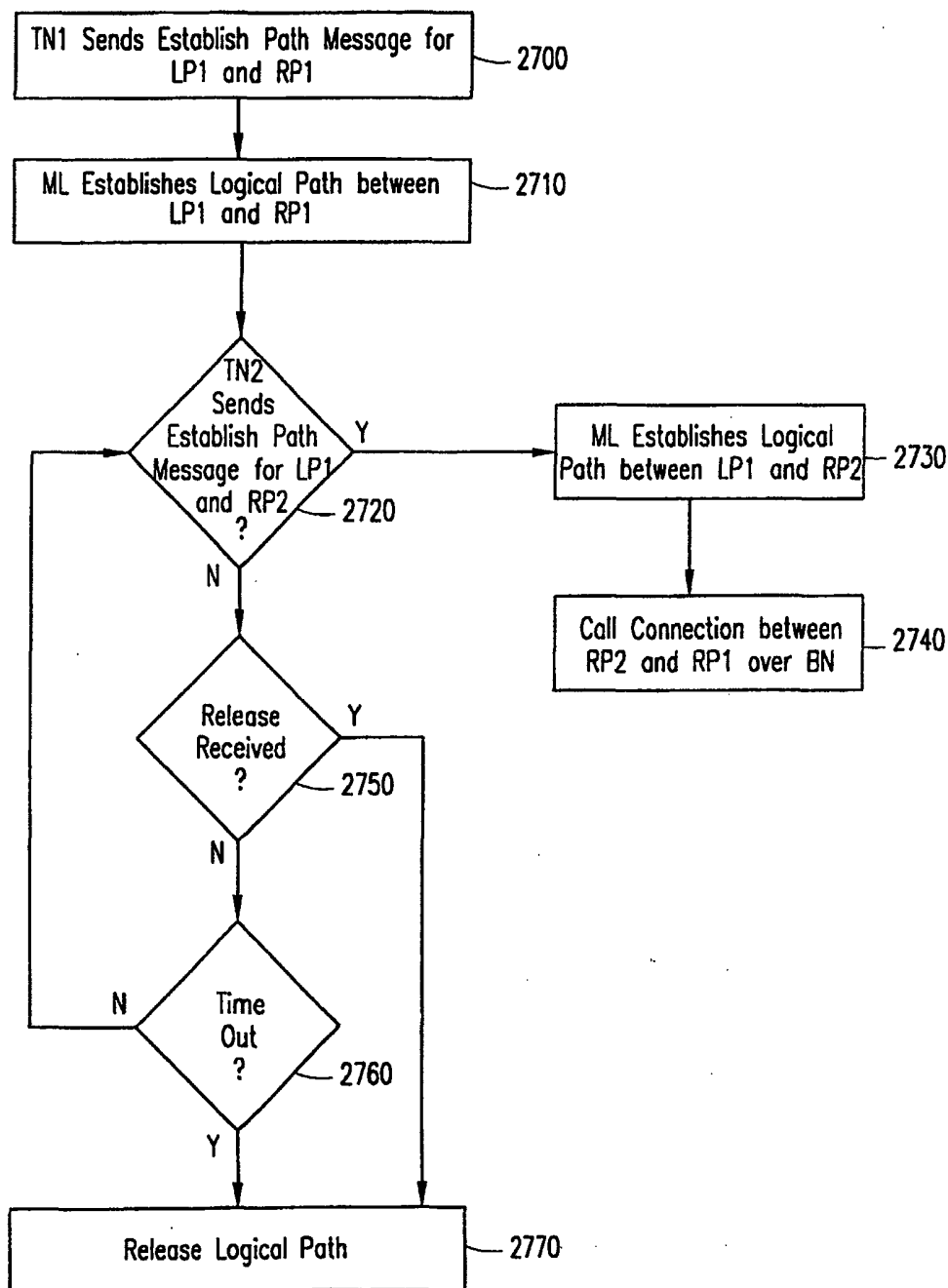

FIG. 27