

March 19, 1935.

C. A. SPIKING
DISMOUNTABLE CASE OR WRAPPER FOR THE RAPID
PACKING AND UNPACKING OF ITS CONTENTS
Filed May 15, 1934

1,994,541

3 Sheets-Sheet 1

Fig. 1

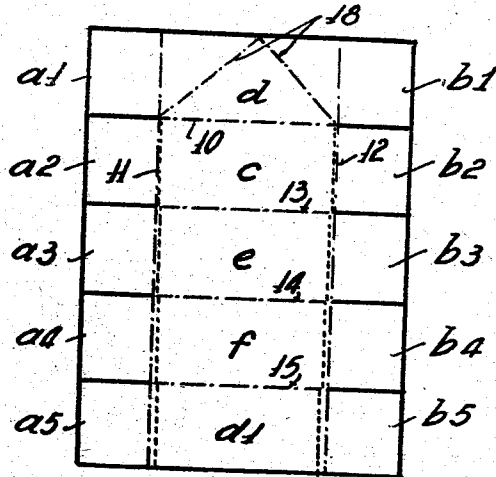

Fig. 2

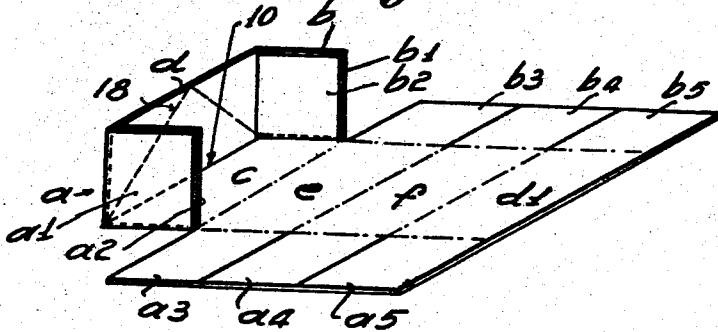

Fig. 4

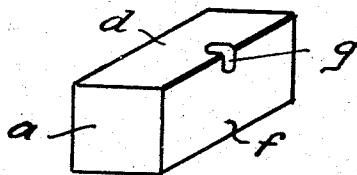
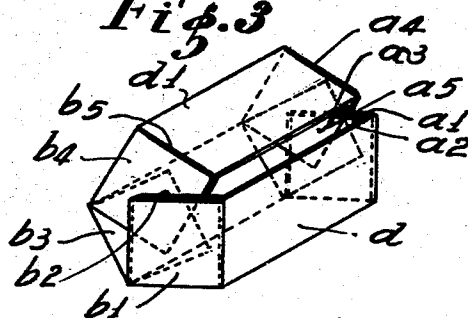

Fig. 3



INVENTOR
CARLOS AGUSTIN SPIKING
BY *Haseltine, Lake & Co.*
ATTORNEYS

March 19, 1935.

C. A. SPIKING
DISMOUNTABLE CASE OR WRAPPER FOR THE RAPID
PACKING AND UNPACKING OF ITS CONTENTS
Filed May 15, 1934

1,994,541

3 Sheets-Sheet 2

Fig. 5

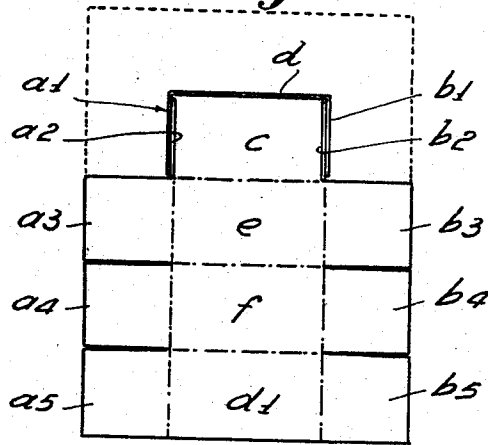

Fig. 6

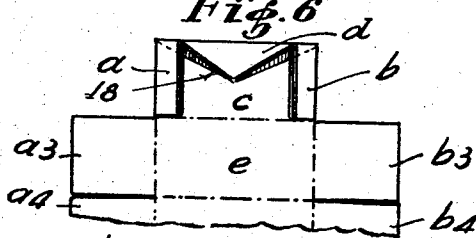

Fig. 9

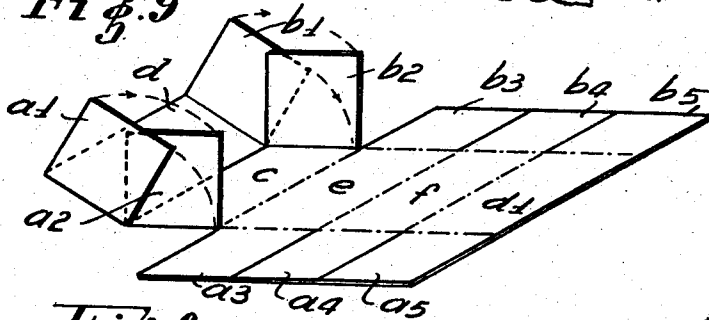

Fig. 8

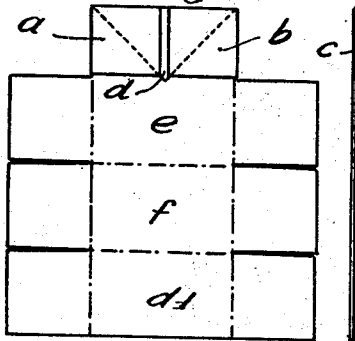

Fig. 10.

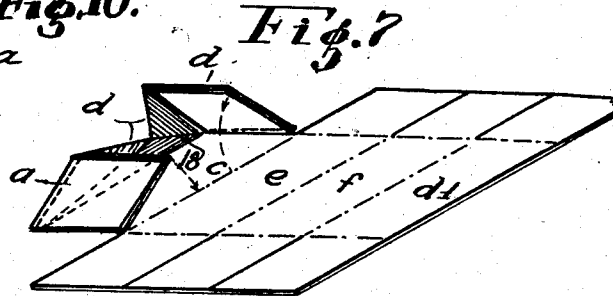

Fig. 7

INVENTOR
CARLOS AGUSTIN SPIKING
BY *Haseltine, Lake & Co.*
ATTORNEYS

March 19, 1935.

C. A. SPIKING
DISMOUNTABLE CASE OR WRAPPER FOR THE RAPID
PACKING AND UNPACKING OF ITS CONTENTS
Filed May 15, 1934

1,994,541

3 Sheets-Sheet 3

Fig. 11.

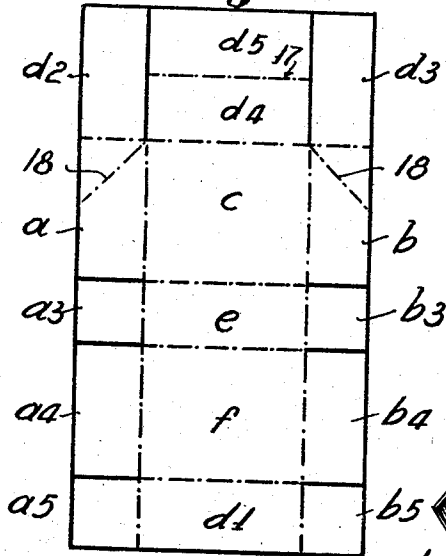

Fig. 12.

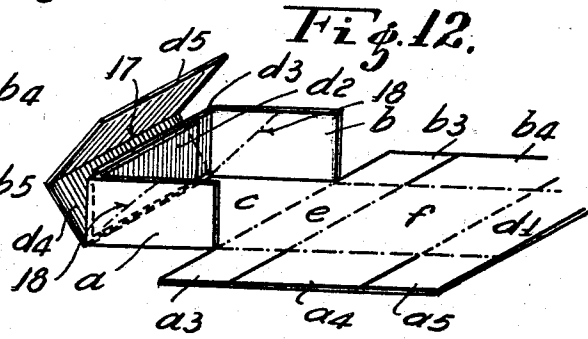

Fig. 13.

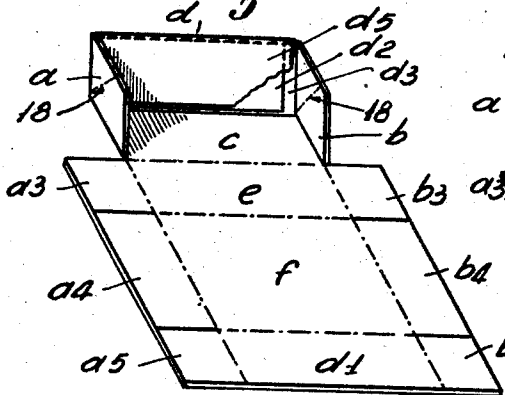

Fig. 14.

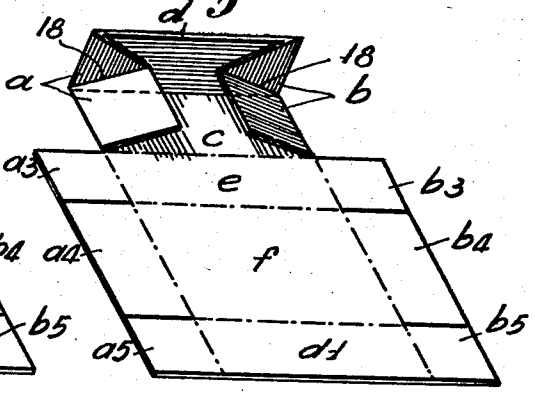
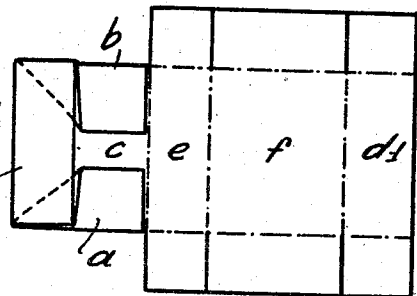

Fig. 15.



INVENTOR
CARLOS AGUSTIN SPIKING
BY *Hasseltine, Lake & Co.*
ATTORNEYS

UNITED STATES PATENT OFFICE

1,994,541

DISMOUNTABLE CASE OR WRAPPER FOR THE RAPID PACKING AND UNPACKING OF ITS CONTENTS

Carlos Agustin Spiking, Buenos Aires, Argentina

Application May 15, 1934, Serial No. 725,686
In Argentina April 28, 1934

1 Claim. (Cl. 229—40)

This invention relates to a collapsible case or wrapper for the rapid packing and unpacking of its contents. The most outstanding feature of the case is that the entrance opening is constituted by the portion that is comprised by two consecutive front faces, the case thus being formed, in its initial aspect, with four faces (two end ones and two front ones) out of the six which correspond to every parallelepiped body, be it rectangular or quadrangular. The remaining faces which are intended to cover the open portions of the case extend, in their initial position, contiguously to one of the two front faces so that they will occupy their respective places upon being folded, and thus close the case or wrapper. In its rough state, i. e., when it is partially made up or erected so as to allow of introducing and taking out the article to be packed therein, it may be folded or collapsed into various shapes with the object in mind to make it less bulky and give it a flat aspect while it is not being used or while it is stored away or conveyed without contents.

The wrapper is preferably made of thin cardboard or other foldable material and in such a manner as to allow of introducing any article therein.

In order that the invention may be fully understood and readily put into practice, it has by way of example been shown in various illustrative figures in the attached drawings wherein:

Figure 1 shows one of the models of the case or wrapper in accordance with the present invention, in totally stretched-out position;

Figure 2 is a perspective view of the same case, partially formed and in the position when it is about to receive or deliver any given article;

Figure 3 shows the case when it is about to be closed or opened;

Figure 4 is a perspective view of the case in the completely closed state;

Figure 5 is a plan view of the same lay-out as Fig. 2, i. e., when the case or wrapper is partially formed so as to receive its contents;

Figure 6 shows the case in plan view when a side portion of the same is about to be folded;

Figure 7 is a perspective view of the same lay-out as shown in Figure 6;

Figure 8 comprises two views, one being a plan view and the other a side elevation, showing the case with the said portion folded;

Figure 9 is a perspective view, showing the case or wrapper at the moment when the side portion of the same is being formed;

Figure 10 is a side or edge view of the partly folded blank shown in Figure 8.

Figure 11 is a totally collapsed form or extension of another, similar type of a case or wrapper;

Figure 12 is a perspective view giving an example of how to form the portion of the case that is side armed;

Figure 13 is a perspective view showing the case with the armed portion thereof when it is about to receive or deliver any given article;

Figure 14 is a perspective view showing the moment when the side armed portion of the case or wrapper is being folded so as to facilitate the stowing away of the cases or wrappers not in use;

Figure 15 is a plan view showing the position which follows the folding of the case as shown in the previous figure, i. e., illustrating the armed portion in the folded state.

In the various figures of the drawings, equal visible parts have been indicated by the same reference numerals or letters.

The construction in accordance with the drawings consists in forming by means of a foldable sheet a parallelepiped case or wrapper provided with four walls, i. e., two lateral ones $a-b$, the base c and the rear front wall d , the base c having various extensions e, f, d^1 which have for their object to close the case, as will be seen later on. The case, therefore, does not possess two consecutive faces while it is open, which would be formed by the walls e and f .

There are various ways of forming the case with the aid of the four walls $a-b-c-d$. In Figures 1 to 5 and 9, an example is given showing how to accomplish the same. As a matter of fact, using the sheet as shown in extension in Fig. 1, in order to form the rear wall d , that portion is folded at an angle of 90° on the line 10, the same as the four arms or wings a^1, a^2, b^1 and b^2 over the lines 11 and 12, so that these wings become superposed by twos in order to form, on their turn, the walls a and b (see Figs. 2 and 5). These wings forming the said walls a and b may be held together by an adhesive, by clips, etc., so as to turn out the case as is shown in Fig. 2.

The wrapping-up walls e, f and d^1 are provided at either side with their corresponding wings a^3, a^4, a^5, b^3, b^4 and b^5 which will join the lateral walls a and b when the case is fully mounted (as will be seen from Figs. 3 and 4).

In all of the views shown, the references indicated by the letters answer the following: letters a and b for the two lateral walls, and the letters c, d, e and f for the four surrounding faces or enlarged fronts of the case. Wall d^1 comes to rest against wall d upon the case being formed, and so forth if the sheet were more extended by means of further surfaces as a continuance of d^1 .

When the case or wrapper is thus formed to its opened position (Figs. 2 and 5), provision has been made to fold it so as to have it occupy but little space when it is utilized, this folding to take place, for instance, in the following manner: wall d is folded on the angular line 18 as shown in

Figs. 6 and 7, so that the lateral walls a and b come to rest against the base c thus producing an assembly such as is illustrated in Fig. 8, i. e., an assembly having a flat shape, when it will not occupy much space during storage.

The accommodation of one or various articles that may be packed within the case or wrapper takes place in the following manner: the case is extended as shown in Figs. 2 and 5, placing the article for example on the base c ; thereupon, the wings a^3 , a^4 , a^5 , b^3 , b^4 and b^5 are folded at 90° longitudinally of the lines 11 and 12, as well as the faces e , f and d^1 longitudinally of the lines 13, 14 and 15, putting them in their corresponding places (Fig. 3) so as to give the case or wrapper its perfect paralleloiped shape (Fig. 4). The wings of equal letters have thus been joined to one another internally, an assembly being thus formed which will be sufficiently strong to contain any appropriate article. A seal "g" (Fig. 4) or any other sealing attachment may be stuck to the case when it is completely closed.

When it is desired to unpack the contents which is quickly done owing to the wrapped-up article being completely accessible to the fingers of the hand, in the first place the seal "g" or other sealing element that may be attached to the case is broken, whereupon the wall d^1 (Fig. 3) is lifted when the whole assembly will be unrolled and present the same aspect as in its initial position, i. e., that shown in Fig. 2. As soon as the case has assumed this position there is nothing that would prevent the contents from being readily taken out, all the more when the same is adjusted in the case or wrapper, as is the case with cigarette-cases and the like.

Nothing would, for instance, prevent the article from being put on the wall e while it is being accommodated in the case, and then proceed with folding the other elements of the sheet so as to form the case in question.

Referring now to Figs. 10 to 14, another form of realization is given there, eliminating the sticky substance or adherence which we saw on the wings a^1 , and a^2 , b^1 and b^2 of the first example, imparting, at the same time, more rigidity to the rear wall d .

Roughly speaking, the type of wrapper has the same features as the first model, for the case consists in its opened position, i. e., when it is ready for receiving or delivering contents, of the four walls, namely: the two lateral ones a and b , the base c , and the rear wall d (Figs. 12, 13 and 14). The base c is provided with the extension that constitutes the walls e , f and d^1 which are used to cover the open portion of the said case. There are also provided the wings a^3 , a^4 , a^5 , b^3 , b^4 and b^5 , in the same manner as in the foregoing model.

The slight difference in form resides in that the wall d is formed as illustrated in Figs. 10 and 11 by the two longitudinal zones d^2 and d^3 bent on the lines 16 and forming the two rear edges, and by the other two zones d^4 and d^5 bent on the first ones along line 17, forming the upper rear edge. The case turns thus out as is shown in Fig. 12, when it is in open position.

If it is desired to give a more certain connection between the rear wall d which, as has been seen, is formed by the four zones d^2 , d^3 , d^4 and d^5 , one or more clips may be applied thereto, or they may be stuck together by a gummy substance, etc.

For storing or conveying the cases or wrappers before using them, they may be folded in the

following manner: the walls a and b are bent on the slanting lines 18 which extend from the lower rear corners to the interior, as may be noted from Fig. 13, whereupon the rear wall d is made to come down on them and on the base c (Fig. 14). Thus, the assembly assumes a flat shape and may be readily stored away in quantities. The folding lines 11 and 12, Fig. 1, in the case of very thick sheets being used should each time move more towards the interior (as is shown in dotted lines) so as to make allowance for the thickness of the portions that join one another.

As regards the way in which the articles that are to be housed in the case should be accommodated within the case, this is performed in the same manner as indicated in the previous case.

It is pointed out that the case formed as shown in Figs. 2 and 12 is provided with an ample entrance for the housing and rapid taking out of the articles it may have for its contents. This entrance, as will have been noted, comprises two sides of the prism and is, therefore, wide enough for the access of the articles to the case.

The shape of the blank or sheet that is used for forming the case is quadrangular, without notches or cut-outs. All it has are cuts made by a knife and the marks or scorings wherealong the foldings are to be made.

The manipulation for opening or closing the case or wrapper is extremely simple, for it is sufficient for the extended portions of the base c to be brought unto their corresponding places so as to have the case assume the shape at which it may be closed, when the free wings a^3 , a^4 , b^4 , etc. will remain inside the case.

In each form of the invention, the same fundamental features appear, that is, the base c has a main front wall equivalent to d and closing wings or end walls similar to a , b , while being connected by means of an intermediate back wall e to a top wall similar to f having an outer front wall similar to d^1 , the latter walls also having closing wings or end walls similar to a^4 , a^5 , and b^4 , b^5 , while the intermediate back wall preferably has end wings or walls similar to a^3 and b^3 .

There are other ways leading to the construction of four walls like those indicated by the letters a , b , c and d , as well as other systems of how to fold the case before using it and after it has been mounted in the manner indicated, but further explanation is dispensed with owing to the fact that the same would go very much into details. The two examples as given in the foregoing are fully sufficient to clear up the spirit of the present invention.

What I claim is:

A box made from a blank having five serially arranged central panels adapted to be folded relatively to each other to constitute a box with one end panel overlapping the other end panel, each end of each panel having a laterally extending flap adapted to be folded at right angles to the central body portion of said box so that the flaps form two series and constitute the ends of the box, while the two corner flaps at each end of each of said two series of flaps are superposed upon each other to constitute a composite end portion and the resulting two end portions formed from each series of flaps overlapping each other to constitute an end of the box in conjunction with the middle flap in the series.

CARLOS AGUSTIN SPIKING.